

T-fal®

EN

CONVECTION AND ROTISSERIE OVEN



Instructions for use

IMPORTANT SAFEGUARDS

When using electrical appliances, basic safety precautions should always be followed, including the following:

- Read all instructions before using.
- Do not touch hot surfaces. Use handles or knobs.
- To protect against electric shock, do not immerse or partially immerse cord, plugs or appliance in water or other liquid.
- Close supervision is necessary when any appliance is used by or near children.
- Unplug from outlet when not in use and before cleaning. Allow to cool before putting on or taking off parts, and before cleaning the appliance.
- Do not operate any appliance with a damaged cord or plug, or after the appliance malfunctions or has been damaged in any manner. Return appliance to the nearest authorized service facility for examination, repair or adjustment. Or, call the appropriate toll-free number on the cover of this manual.
- The use of accessory attachments not recommended by the appliance manufacturer may cause injuries.
- Do not use outdoors.
- Do not let cord hang over the edge of table or counter, or touch hot surfaces.
- Do not place on or near a hot gas or electric burner, or in a heated oven.
- Extreme caution must be used when moving an appliance containing hot oil or other hot liquids.
- To disconnect, turn any control to OFF, then remove plug from wall outlet.
- To switch off the appliance turn Timer knob to OFF position.
- Do not use appliance for other than intended use.
- Use extreme caution when removing tray or disposing of hot grease.
- Do not clean with metal scouring pads. Pieces can break off the pad and touch electrical parts, creating a risk of electric shock.
- Oversized foods or metal utensils must not be inserted in a toaster oven, as they may create a fire or risk of electric shock.
- A fire may occur if the toaster oven is covered or touching flammable material including curtains, draperies, walls and the like, when in operation. Do not store any item on top of the appliance when in operation.
- Extreme caution should be exercised when using containers constructed of other than metal or glass.
- Do not store any material, other than manufacturer's recommended accessories, in this oven when not in use.
- Do not place any of the following materials in the oven: paper, cardboard, plastic, and the like.
- Do not cover crumb tray or any part of this oven with metal foil. This will cause overheating of the oven.

**SAVE THESE INSTRUCTIONS.
THIS APPLIANCE IS FOR HOUSEHOLD USE ONLY.**

Grounded plug

- As a safety feature, this appliance is equipped with a grounded plug, which will only fit into a three-prong outlet. Do not attempt to defeat this safety feature. Improper connection of the grounding conductor may result in the risk of electric shock. Consult a qualified electrician if you are in doubt as to whether the outlet is properly grounded.

Electrical cord

- a) A short power-supply cord is to be provided to reduce the risk resulting from becoming entangled in or tripping over a longer cord.
- b) Longer extension cords are available and may be used if care is exercised in their use.
- c) If an extension cord is used,
 - 1) The marked electrical rating of the cord set or extension cord should be at least as great as the electrical rating of the appliance, and
 - 2) The cord should be arranged so that it will not drape over the countertop or tabletop where it can be pulled on by children or tripped over unintentionally. If the appliance is of the grounded type, the extension cord should be a grounding-type 3-wire cord.

Warning: To reduce the risk of fire or electric shock, do not attempt to remove the outer cover. There are no user-serviceable parts inside. Repair should be done only by authorized service personnel.

Note: If the power supply cord is damaged, it should be replaced by qualified personnel; in Latin America by an authorized service center.

DO NOT USE APPLIANCE FOR OTHER THAN INTENDED USE.

If you have any problems, contact the authorized after-sales service center.

Thank you for buying this appliance. Read the instructions in this leaflet carefully and keep them within reach. Any commercial use, inappropriate use or failure to comply with the instructions, the manufacturer accepts no responsibility and the guarantee will not apply.

For your safety, this product conforms to all applicable standards and regulations (Electric Safety, Food Compliant Materials, Environment, ...).

EN

Our company has an ongoing policy of research and development and may modify these products without prior notice.

- Only use parts or accessories provided with the appliance or bought from an Approved Service Center. Do not use them for other appliances or intentions.
- To avoid damaging your appliance, do not use flambé recipes with it at any time.

Prevention of accidents at home

- This appliance is not intended for use by persons (including children) with reduced physical, sensory or mental capabilities, or lack of experience and knowledge, unless they have been given supervision or instruction concerning use of the appliance by an adult responsible for their safety. Children should be supervised to ensure that they do not play with the appliance.
- Accessible surface temperatures can be high when the appliance is operating. Never touch the hot surfaces of the appliance, always use the handles.
- As this appliance is for household use only, it is not intended for use in the following applications and the guarantee will not apply for:
 - staff kitchen areas in shops, offices and other working environments;
 - farm houses;
 - by clients in hotels, motels and other residential type environments;
 - bed and breakfast type environments.
- This appliance is not intended to function using an external time-switch or a separate remote control system.
- Do not use the appliance if:
 - it has faulty or damaged power cord,
 - the appliance has been dropped and shows visible signs of damage or malfunction.



Environment protection first!

① Your appliance contains valuable materials which can be recovered or recycled.

➡ Leave it at a local civic waste collection point.

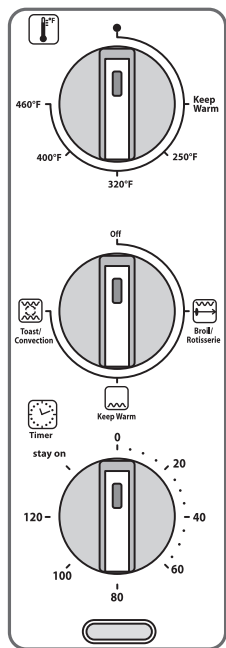
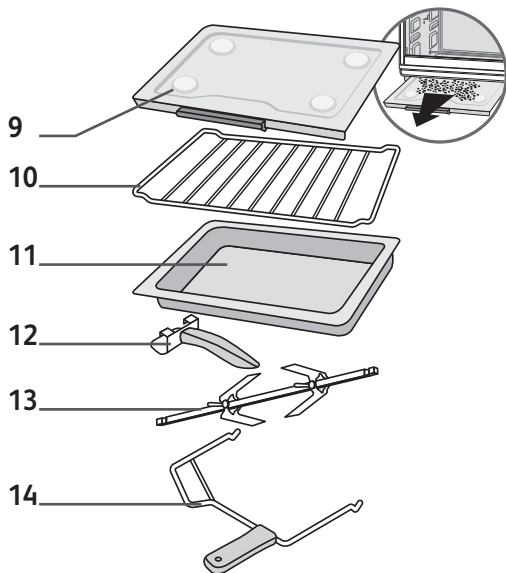
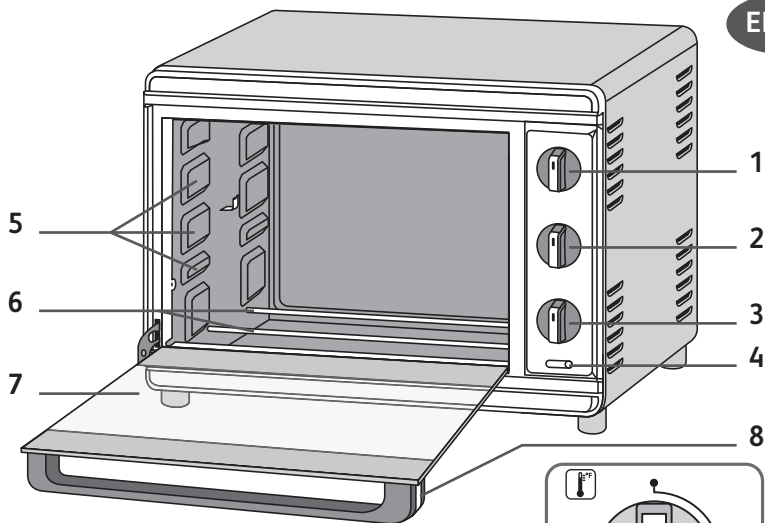

Description

- | | |
|-----------------------|--|
| 1 Thermostat | 8 Door handle |
| 2 Function switch | 9 Crumb tray |
| 3 Timer | 10 Chrome bake rack |
| 4 Indicator light | 11 Bake pan |
| 5 Rack support guides | 12 Tray/Rack handle |
| 6 Heating elements | 13 Rotisserie forks with screws/ Rotisserie spit |
| 7 Glass door | 14 Rotisserie handle |

Before using for the first time

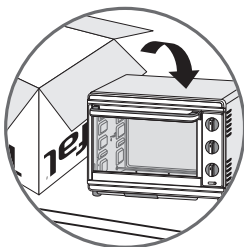
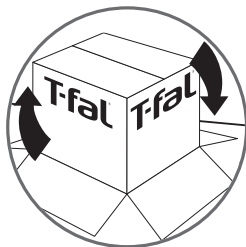
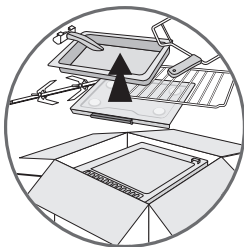
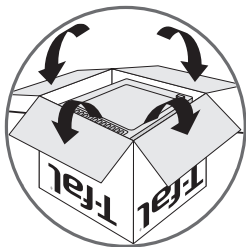

Remove all packaging materials and take out the appliance **without holding it by the handle.**

Read all the instructions for use and the important safeguards and follow them carefully.

Wash all accessories in warm, soapy water. Rinse and dry carefully. Unroll the power cord completely.

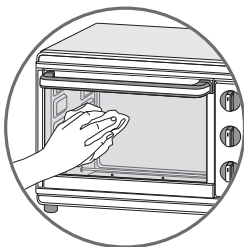
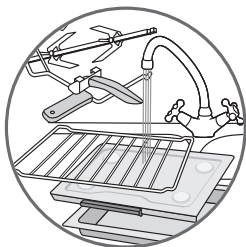

Wipe the outside of the appliance with a damp cloth and dry.

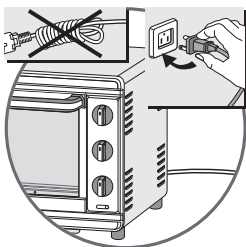
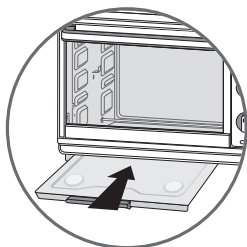

Plug in the toaster oven.
Put the crumb tray back in place.

In order to remove any possible residues from manufacturing, run the appliance empty for 20 minutes.

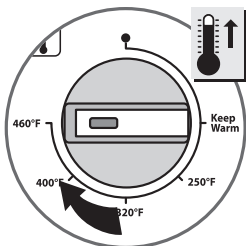
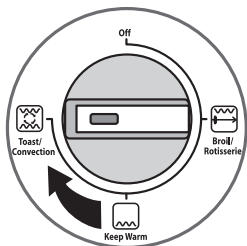

Select the Oven function and set the temperature dial to **460°F (240°C)**.

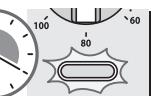
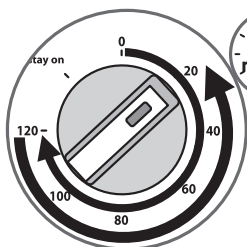

Set the timer dial to 20 minutes.

The power indicator light will now turn on indicating the toaster oven is now heating up.

You may observe smoke escaping from the oven.

This is normal and will gradually disappear with use.

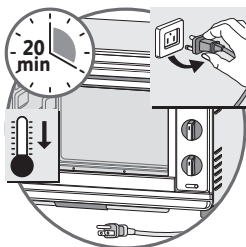
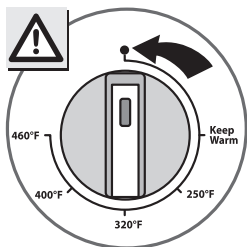

Once the timer has stopped, you will hear a beep. Turn the thermostat button to position •.

Let the appliance cool down before unplugging it.

EN Rack positions

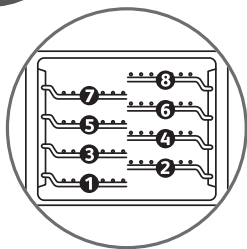

For all functions the position of the cooking rack will play an important role in the final cooking result. Note that there are 8 separate positions for the cooking rack. Place your tray in the center of the rack at the desired height.

Warning: Do not pull the cooking rack more than 2/3-out.

Helpful hints about your oven

- When selecting baking time for a particular recipe, include preheat time.
- This oven has a 120 minute timer.
- Metal, ovenproof glass and ceramic bakeware without lids can be used in the oven.
- Turn all controls to **Off** before inserting or removing plug from electrical outlet.
- Cooking times are provided at the back of the manual. These are only estimated times and can vary depending on the dish used, the size, thickness, freshness and initial temperature of the food to be cooked.
- Do not put any container directly on the lower heating element.
- To obtain the best performance from this toaster oven:
 - Do not overfill the oven;
 - To avoid heat loss do not open the door too frequently.

Crumb tray

The crumb tray should be cleaned in warm soapy water.
(Do not wash the crumb tray in the dishwasher).

Leave the crumb tray in place while the appliance is in operation.

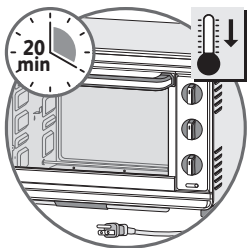

Do not touch the crumb tray during or immediately after operation.
Allow to cool completely.

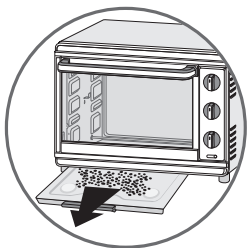

Remember to empty the crumb tray after every use.

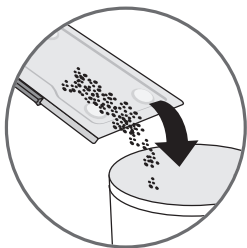

Toast/Convection function

Warning:

1. Never leave unattended during use.
2. Do not use the « stay on » function.

Plug in the toaster oven.
Insert the rack at the desired level.
Select the **Toast/Convection** function.

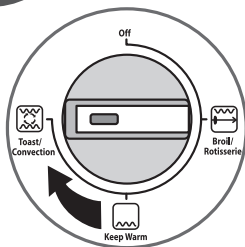

Set the temperature dial to the desired temperature

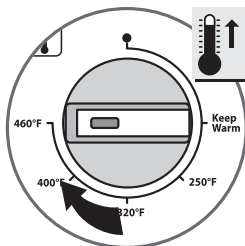

Set the timer dial on the desired cooking time.
The power indicator light turns on and cooking starts.

Timer: turn the knob to 120 minutes, then turn dial counter clockwise back to the desired time.

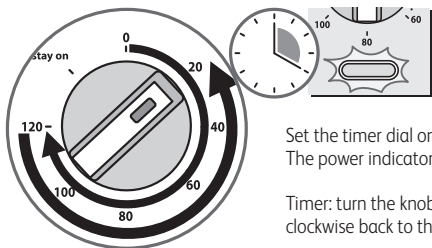

If preheating is necessary, wait for the time indicated in the cooking table and then place the food on the rack using a suitable dish.

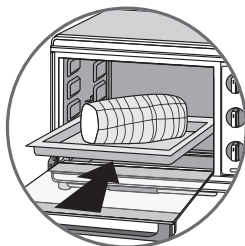

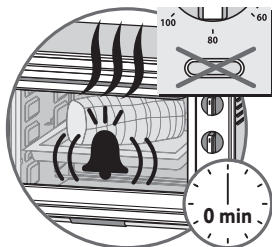

When cooking is completed, you will hear a beep and the timer automatically returns to the off position, the power indicator light will turn off.

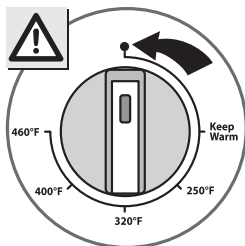

Turn the temperature dial to the position •.

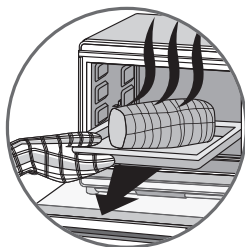

Using oven mitts or pot holders, lower oven door to the full open position and remove the cooked food.

You can also use the Tray/Rack handle.

Let the appliance cool down before unplug it.

EN Broil function

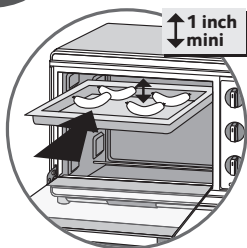

Warning:

1. Never leave unattended during use.
2. Do not use the « stay on » function.

Plug in the toaster oven. Use shelf position #7. There must be a minimum space of 1 inch (2 cm) between the food and the top elements.

Note: Be sure food does not extend past the outer limits of the bake tray to prevent grease dripping onto the bottom heating elements.

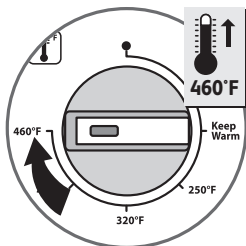
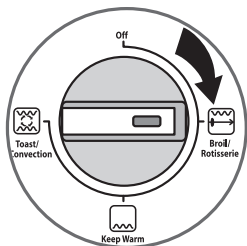

Close the door. Select the **Broil** function. Set the temperature dial on the highest temperature.

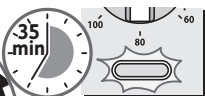
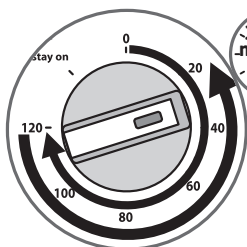

Set the timer dial on the desired time. The power indicator light turns on.

Timer: turn the knob to 120 minutes, then turn dial counter clockwise back to the desired time.

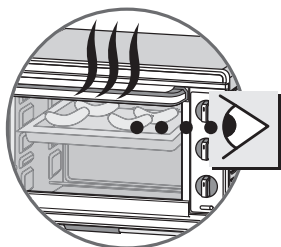

Monitor the food and for best results turn it over.

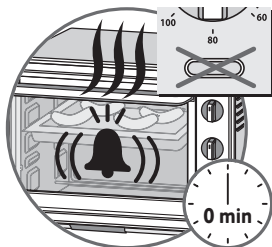

When the cycle is completed, you will hear a beep, the timer automatically returns to the off position and the power indicator light turn off.

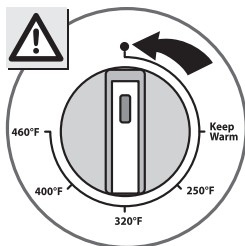

Turn the temperature dial to the position •.

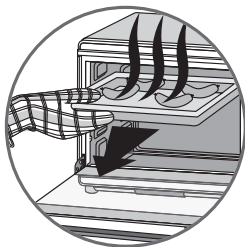

Using oven mitts or pot holders, lower oven door to the full open position and remove the cooked food.

You can also use the Tray/Rack handle.

EN Rotisserie function

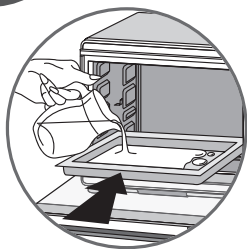

Warning:

1. Never leave unattended during use.
2. Do not use the « stay on » function.

Plug in the toaster oven.
Insert the tray at the lowest position.
Pour water in the tray 10 fl oz (30 cl).

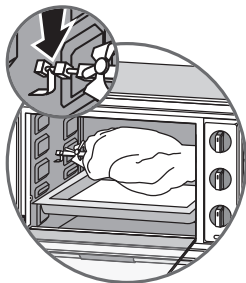
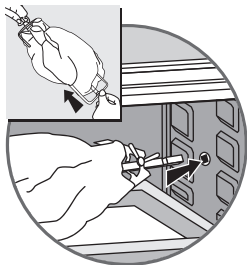

Place the poultry
or meat onto the spit.

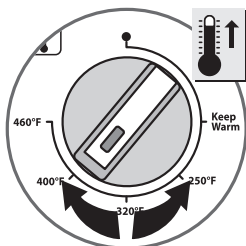
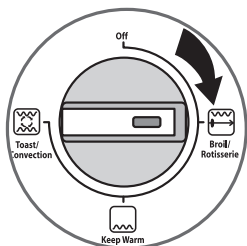

Select the **Rotisserie**
function.

Note: Be sure poultry
does not extend past
the outer limits of
the bake tray to prevent
grease dripping
onto the bottom
heating elements.

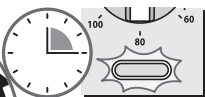
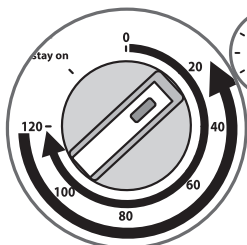

Close the door.

Set the timer dial on the desired time.
The power indicator light turns on.

Timer: turn the knob to 120 minutes, then turn dial counter
clockwise back to the desired time.

Monitor the poultry.

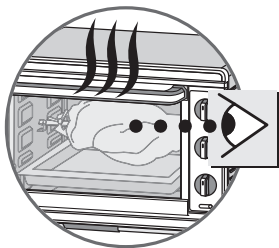

When cooking is completed, you will hear a beep and the timer automatically returns to the **Off** position, the power indicator light turns off.

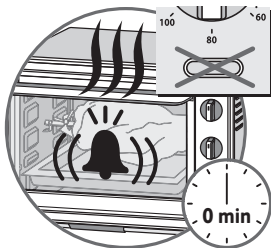

Turn the temperature dial to the position •.

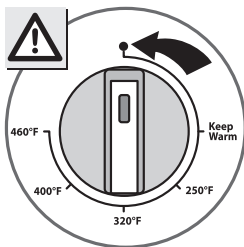

Using oven mitts or pot holders, lower oven door to the full open position and remove the cooked poultry.

You can also use the Rotisserie handle.

EN Keep warm function

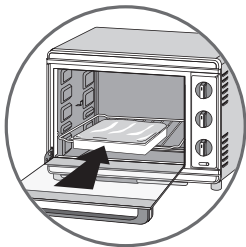
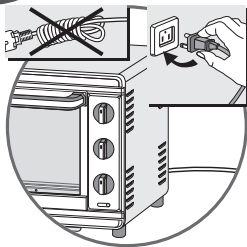

Never leave unattended during use.

Plug in the toaster oven.

Place the food on the rack using an appropriate dish.

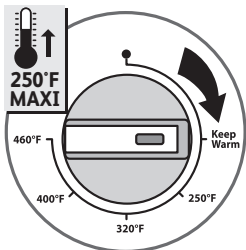
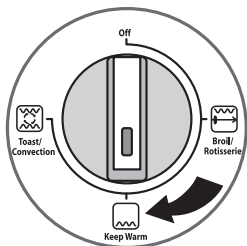

Select the **Keep Warm** function.

You have two options:

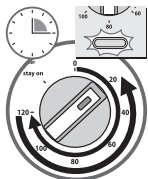

Set the timer dial on the desired cooking time. The power indicator light turns on and keep warm starts.

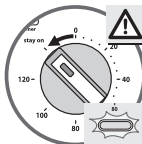

Set the timer dial on **Stay on**. The power indicator light turns on and keep warm starts.



Keep a watch...

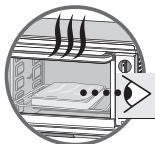

Keep a watch...

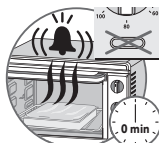

When keep warm is completed, you will hear a beep and the timer automatically returns to the off position, the power indicator light turns off.

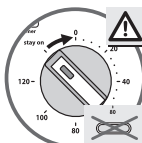

To stop the keep warm function, turn the timer button to **Off** position; the indicator light will turn off.

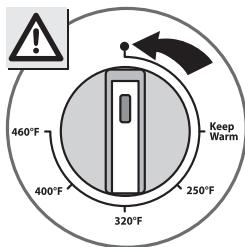

Turn the temperature dial to the position •.

Using oven mitts or pot holders, lower oven door to the full open position and remove the cooked food.

Let the appliance cool down for 20 minutes before unplugging it.

Cleaning and care

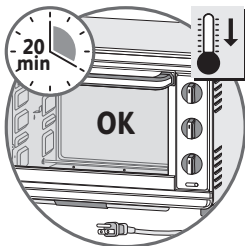
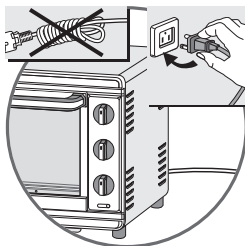

Do not allow grease to accumulate inside the appliance.

Let the appliance cool down completely and disconnect it before cleaning or storing.

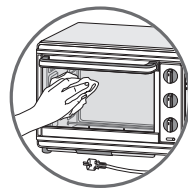
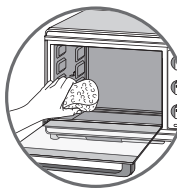
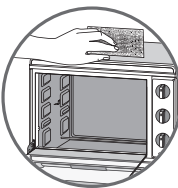

Do not use aggressive cleaning products (especially oven cleaners or metal or abrasive pads).







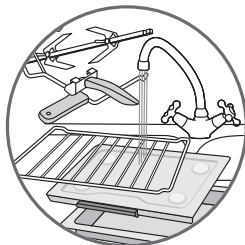

A quick wipe with a sponge is sufficient to clean the outside of the appliance.

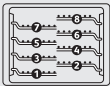
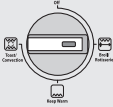
Clean the door, enameled or lacquered surfaces and translucent parts with a damp sponge and a mild detergent.

Do not use cleaning products intended for metals (for stainless steel, copper etc.).

The inside walls of the oven are non-stick and can be cleaned easily with water and detergent.



Bread crust color				Pre-heating	
Light			460°F / 240°C	5 min.	5 min. + 1.55 min.
Medium			460°F / 240°C	5 min.	8 min. + 2.36 min.
Dark			460°F / 240°C	5 min.	13 min. + 3.55 min.

The above informations is just for reference. You should adjust it according to your personal taste or recipe guidelines.

Please pay attention to food in the oven when cooking.

TEFAL / T-FAL* INTERNATIONAL LIMITED GUARANTEE

EN

 : www.tefal.com <http://www.groupeseb.com/>

This product is repairable by TEFAL / T-FAL, during and after the guarantee period.

The Guarantee

This product is guaranteed by TEFAL / T-FAL (company address and details included in the country list of the TEFAL / T-FAL International Guarantee) against any manufacturing defect in materials or workmanship during the guarantee period within those countries as stated in the Country List on the last page of the user manual, starting from the initial date of purchase.

The international manufacturer's guarantee by TEFAL / T-FAL is an extra benefit which does not affect consumer's Statutory Rights.

The international manufacturer's guarantee covers all costs related to restoring the proven defective product so that it conforms to its original specifications, through the repair or replacement of any defective part and the necessary labour. At TEFAL / T-FAL's choice, a replacement product may be provided instead of repairing a defective product. TEFAL / T-FAL's sole obligation and your exclusive resolution under this guarantee are limited to such repair or replacement.

Conditions & Exclusions

The international TEFAL / T-FAL guarantee only applies within the guarantee period and for those countries listed in the Country List attached and is valid only on presentation of a proof of purchase. The product can be taken directly in person to an authorised service centre or must be adequately packaged and returned, by recorded delivery (or equivalent method of postage), to a TEFAL / T-FAL authorised service centre. Full address details for each country's authorised service centres are listed on TEFAL / T-FAL website (www.tefal.com/<http://www.tefal.com>) or by calling the appropriate telephone number as set out in the Country List to request the appropriate postal address.

TEFAL / T-FAL shall not be obliged to repair or replace any product which is not accompanied by a valid proof of purchase.

This guarantee will not cover any damage which could occur as a result of misuse, negligence, failure to follow TEFAL / T-FAL instructions, use on current or voltage other than as stamped on the product, or a modification or unauthorised repair of the product. It also does not cover normal wear and tear, maintenance or replacement of consumable parts, or the following:

- using the wrong type of water or consumable
- scaling (any de-scaling must be carried out according to the instructions for use)
- ingress of water, dust or insects into the product
- mechanical damages, overloading
- damages or bad results due to wrong voltage or frequency
- accidents including fire, flood, thunderbolt, etc
- professional or commercial use
- damage to any glass or porcelain ware in the product
- replacement of consumables

This guarantee does not apply to any product that has been tampered with, or to damages incurred through improper use and care, faulty packaging by the owner or mishandling by any carrier.

The international TEFAL / T-FAL guarantee applies only for products purchased in one of the countries listed, and used for domestic purposes only in one of the countries listed on the Country List. Where a product purchased in one listed country and then used in another listed country:

- a) The international TEFAL / T-FAL guarantee duration is the one in the country of usage of the product, even if the product was purchased in another listed country with different guarantee duration.
- b) The international TEFAL / T-FAL guarantee does not apply in case of non conformity of the purchased product with the local standards, such as voltage, frequency, power plugs, or other local technical specifications.
- c) The repair process for products purchased outside the country of use may require a longer time if the product is not locally sold by TEFAL / T-FAL.
- d) In cases where the product is not repairable in the new country, the international TEFAL / T-FAL guarantee is limited to a replacement by a similar product or an alternative product at similar cost, where possible.

Consumer Statutory Rights





This international TEFAL / T-FAL guarantee does not affect the statutory rights a consumer may have or those rights that cannot be excluded or limited, nor rights against the retailer from which the consumer purchased the product. This guarantee gives a consumer specific legal rights, and the consumer may also have other legal rights which vary from State to State or Country to Country. The consumer may assert any such rights at his sole discretion.





Additional information





Accessories, consumables and end-user replaceable parts can be purchased, if locally available, as described on the TEFAL / T-FAL internet site.

* TEFAL household appliances appear under the T-FAL brand in some territories like America and Japan. TEFAL/T-FAL are registered trademarks of Groupe SEB.

INTERNATIONAL GUARANTEE : COUNTRY LIST

			
الجزائر ALGERIA	CIJA 9 rue Puvis de Chavannes - Saint Euquene Oran	(0)41 28 18 53	1 an 1 year
ARGENTINA	GRUPE SEB ARGENTINA S.A. Billinghurst 1833 3° - C1425DTK Capital Federal - Buenos Aires	0800-122-2732	2 años 2 years
ՀԱՅԱՍՏԱՆ ARMENIA	ՓԲԸ Գրուպպա ՍԵԲ-Վ, 125171 Մոսկվա, Լենինգրադային ի թեմալի, 16A, Է.Ի.Յ	(010) 55-76-07	2 տարի/ 2 years
AUSTRALIA	GRUPE SEB AUSTRALIA PO Box 7535, Silverwater NSW 2128	02 97487944	1 year
ÖSTERREICH AUSTRIA	SEB ÖSTERREICH HmbH Campus 21 - Businesspark Wien Süd Liebermannstr. A02 702 - 2345 Brunn am Gebirge	01 866 70 299 00	2 Jahre 2 years
BELGIQUE BELGIE BELGIUM	GRUPE SEB BELGIUM SA NV 25 avenue de l'Espérance - ZI 6220 Fleurus	070 23 31 59	2 ans 2 years
БЕЛАРУСЬ BELARUS	ЗАО «Група СЕБ-Восток», 125171, Москва, Ленинградское - шоссе, д. 16А, стр. 3	017 2239290	2 года 2 years
BOSNA I HERCEGOVINA	SEB Développement Predstavništvo u BiH - Vrazova 8/II 71000 Sarajevo	Info-linija za potrošače 033 551 220	2 godine 2 years
BRASIL BRAZIL	SEB COMERCIAL DE PRODUTOS DOMÉSTICOS LTDA Rua Venâncio Aires, 433/437/447, Pompéia, São Paulo/SP	0800-119933	1 ano 1 year
БЪЛГАРИЯ BULGARIA	ГРУП СЕБ БЪЛГАРИЯ ЕООД Ул. Борово 52 Г, ет. 1, офис 1, 1680 София	0700 10 330	2 години 2 years
CANADA	GRUPE SEB CANADA 345 Passmore Avenue Toronto, ON M1V 3N8	800-418-3325	1 an 1 year
CHILE	GRUPE SEB CHILE Comercial Ltda Av. Providencia, 2331, piso 5, oficina 501 Santiago	12300 209207	2 años 2 years
COLOMBIA	GRUPE SEB COLOMBIA Apartado Aereo 172, Kilometro 1 Via Zipaquirá - Cajica Cundinamarca	18000919288	2 años 2 years
HRVATSKA CROATIA	SEB Développement S.A.S. Vodnjanska 26 10000 Zagreb	01 30 15 294	2 godine 2 years
ČESKÁ REPUBLIK CZECH REPUBLIC	GRUPE SEB ČR spol. s r. o. Jankovcova 1569/2c 170 00 Praha 7	731 010 111	2 roky 2 years
DANMARK	GRUPE SEB NORDIC AS Tempovej 27 2750 Ballerup	44 663 155	2 år 2 years
DEUTSCHLAND GERMANY	GRUPE SEB DEUTSCHLAND GmbH / KRUPS GmbH Herrnrainweg 5 63067 Offenbach	0212 387 400	2 Jahre 2 years
EESTI ESTONIA	GRUPE SEB POLSKA SP Z O.O. ul. Bukowińska 22b 02-703 Warszawa	5 800 3777	2 aastat 2 years
SUOMI FINLAND	Group SEB Finland Kutojantie 7 02630 Espoo	09 622 94 20	2 Vuotta 2 years

			
FRANCE Incluant uniquement Guadeloupe, Martinique, Réunion, Saint-Martin	GRUPE SEB FRANCE Service Consommateur Tefal BP 15 - 69131 ECULLY CEDEX	09 74 50 47 74	1 an 1 year
ΕΛΛΑΔΑ GREECE	SEB GROUPE ΕΛΛΑΔΟΣ Α.Ε. Οδός Καβαλιεράτου 7 Τ.Κ. 145 64 Ν. Κηφισιά	2106371251	2 χρόνια 2 years
香港 HONG KONG	SEB ASIA Ltd. Room 903, 9/F, North Block, Skyway House 3 Sham Mong Road, Tai Kok Tsui, Kowloon - Hong-Kong	852 8130 8998	1 year
MAGYARORSZÁG HUNGARY	GRUPE SEB CENTRAL-EUROPE Kft. Táviró köz - 4 2040 Budaörs	06 1 801 8434	2 év 2 years
INDONESIA	Groupe SEB Indonesia (Representative office) Sudirman Plaza, Plaza Marein 8th Floor JL Jendral Sudirman Kav 76-78, Jakarta 12910, Indonesia	+62 21 5793 6881	1 year
ITALIA ITALY	GRUPE SEB ITALIA S.p.A. Via Montefeltro, 4 - 20156 Milano	199207354	2 anni 2 years
JAPAN	GRUPE SEB JAPAN Co. Ltd. 1F Takanawa Muse Building, 3-14-13, Higashi Gotanda, Shinagawa-Ku, Tokyo 141-0022	0570-077772	1 year
ҚАЗАҚСТАН KAZAKHSTAN	ЖАҚ «Группа СЕБ- Восток» 125171, Мәскеу, Ленинградское шоссесі, 16А, 3 үйі	727 378 39 39	2 жыл 2 years
KOREA	(유)그룹 세브 코리아 서울시 종로구 서린동 88 서린빌딩 3층 - 110-790	1588-1588	1 year
LATVJA LATVIA	GRUPE SEB POLSKA Sp. z o.o. ul. Bukowińska 22b 02-703 Warszawa	6 716 2007	2 gadi 2 years
LIETUVA LITHUANIA	GRUPE SEB POLSKA Sp. z o.o. ul. Bukowińska 22b 02-703 Warszawa	6 470 8888	2 metai 2 years
LUXEMBOURG	GRUPE SEB BELGIUM SA NV 25 avenue de l'Espérance - ZI 6220 Fleurus	0032 70 23 31 59	2 ans 2 years
MACEDONIA	Groupe SEB Bulgaria EOOD Office 1, floor 1, 52G Borovo St., 1680 Sofia - Bulgaria ГРУП СЕБ БЪЛГАРИЯ ДООЕЛ Ул. Борово 52 Г, сл. 1, офис 1, 1680 София - България	(0)2 20 50 022	2 годин 2years
MALAYSIA	GRUPE SEB MALAYSIA SDN. BHD Unit No. 402-403, Level 4, Uptown 2, No. 2, Jalan SS21/37, Damansara Uptown, 47400, Petaling Jaya, Selangor D.E. Malaysia	65 6550 8900	1 year
MEXICO	G.S.E.B. MEXICANA, S.A. DE C.V. Goldsmith 38 Desp. 401, Col. Polanco - Delegacion Miguel Hidalgo 11 560 Mexico D.F.	(01800) 112 8325	1 años 1 year
MOLDOVA	ТОВ «Груп СЕБ Україна» 02121, Харківське шосе, 201-203, 3 поверх, Київ, Україна	(22) 929249	2 ani 2 years
NEDERLAND The Netherlands	GRUPE SEB NEDERLAND BV Generatorstraat 6 - 3903 LJ Veenendaal	0318 58 24 24	2 jaar 2 years
NEW ZEALAND	GRUPE SEB NEW ZEALAND Unit E, Building 3, 195 Main Highway, Ellerslie, Auckland	0800 700 711	1 year
NORGE NORWAY	GRUPE SEB NORDIC AS Tempovej 27 2750 Ballerup DANMARK	815 09 567	2 år 2 years
PERU	Groupe SEB Perú Av. Camino Real N° 111 of. 805 B San Isidro - Lima - Perú	441 4455	1 años 1 year

			
POLSKA POLAND	GRUPE SEB POLSKA Sp. z o.o ul. Bukowińska 22b 02-703 Warszawa	0 801 300 421 koszt jak za połączenie lokalne	2 lata 2 years
PORTUGAL	GRUPE SEB IBÉRICA SA Urb. da Matinha - Rua Projectada à Rua 3 Bloco1 - 3° B/D 1950 - 327 Lisboa	808 284 735	2 anos 2 years
REPUBLIC OF IRELAND	GRUPE SEB IRELAND Unit B3 Aerodrome Business Park, College Road, Rathcoole, Co. Dublin	01 677 4003	1 year
ROMÂNIA ROMANIA	GRUPE SEB ROMÂNIA Str. Daniel Constantin nr. 8 - 010632 București	0 21 316 87 84	2 ani 2 years
РОССИЯ RUSSIA	ЗАО «Группа СЕБ-Восток», 119180 Москва, 125171, Москва, Ленинградское шоссе, д. 16А, стр. 3	495 213 32 30	2 года 2 years
SRBIJA SERBIA	SEB Développement Đorđa Stanojevića 11b 11070 Novi Beograd	060 0 732 000	2 godine 2 years
SINGAPORE	GRUPE SEB SINGAPORE Pty Ltd. 59 Jalan Pemimpin, #04-01/02 L&Y Building Singapore 577218	65 6550 8900	1 year
SLOVENSKO SLOVAKIA	GRUPE SEB SLOVENSKO s.r.o. Rybničná 40 - 831 07 Bratislava	233 595 224	2 roky 2 years
SLOVENIJA SLOVENIA	SEB d.o.o Gregorčičeva ulica 6 - 2000 MARIBOR	02 234 94 90	2 leti 2 years
ESPAÑA SPAIN	GRUPE SEB IBÉRICA S.A. C/ Almogàvers, 119-123, Complejo Ecurban 08018 Barcelona	902 31 24 00	2 años 2 years
SVERIGE SWEDEN	TEFAL SVERIGE SUBSIDIARY OF GROUP SEB NORDIC Truckvägen 14 A, 194 52 Upplands Väsby	08 594 213 30	2 år 2 years
SUISSE / SCHWEIZ SWITZERLAND	GRUPE SEB SCHWEIZ GmbH Thurgauerstrasse 105 8152 Glattbrugg	044 837 18 40	2 ans 2 Jahre 2 years
TAIWAN	SEB ASIA Ltd. Taiwan Branch 4F., No. 37 Dexing W. Rd., Shilin Dist., Taipei City 11158, Taiwan (R.O.C.)	886-2-2833 3716	1 year
THAILAND	GRUPE SEB THAILAND 2034/66 Italthai Tower, 14th Floor, n° 14-02, New Phetchburi Road, Bangkapi, Huaykwang, Bangkok, 10320	662 351 8911	2 years
TÜRKIYE TURKEY	GRUPE SEB ISTANBULAS Beybi Giz Plaza Dereboyu Cad. - Meydan Sok. No: 28 K.12 Maslak	216 444 40 50	2 YIL 2 years
U.S.A.	GRUPE SEB USA 2121 Eden Road - Millville, NJ 08332	800-395-8325	1 year
УКРАЇНА UKRAINE	ТОВ «Груп СЕБ Україна» 02121, Харківське шосе, 201-203, 3 поверх, Київ, Україна	044 492 06 59	2 роки 2 years
UNITED KINGDOM	GRUPE SEB UK LTD Riverside House, Riverside Walk Windsor, Berkshire, SL4 1NA	0845 602 1454	1 year
VENEZUELA	GRUPE SEB VENEZUELA Av Eugenio Mendoza, Centro Letonia, Torre ING Bank, Piso 15, Ofc 155 - Urb. La Castellana, Caracas	0800-7268724	2 años
VIETNAM	Vietnam Fan Joint Stock Company 25 Nguyen Thi Nho Str, Ward 9, Tan Binh Dist, HCM city	+84-8 38644037 +84-8 38645830	1 year

TEFAL / T-FAL INTERNATIONAL GUARANTEE

Date of purchase: / Date d'achat / Fecha de compra / Data da compra / Data d'acquisto / Kaufdatum / Aankoopdatum / Købsdato / Inköpsdatum / Kjøpsdato / Ostopäivä / Data zakupu / Data vânzării / Įsigijimo data/ Ostukuupäev / Datum nakupa / Sorozatszám / Dátum nákupu / Pirkuma datums / Datum Kupovine / Datum kupnje / Data cumpărării / Datum nákupu / Tarikh pembelian / Tanggal pembelian / Ngày mua hàng/ Satin alma tarihi / Дата прџдажи / Дата на закупуване / Датум на купување / Сатылган мерзімі / Ημερομηνία αγοράς/ Ὑπερμνηστική οργη / วันที่ซื้อ / 購買日期 / 購入日 / 구입일자 / خرید تاريخ / خرید تاريخ الشراء

Product reference: / Référence du produit / Referencia del producto / Referência do produto / tipo de prodotto / Typnummer des Gerätes / Artikelnummer van het apparaat / Referencenummer / Produktreferens / Artikelnummer / Tuotenumero / referenca produktu / Model / Gaminio numeris / Toote viitenumber / Tip aparata / Vásárlás kelte / Typ výrobu / Produkta atsauces numurs / Model proizvoda / Oznaka proizvoda / Cod produs / Produk rujukan / Referensi produk / Mã sản phẩm/ Ürün kodu / Мпдель / Мпдель / Мпдел на уреда / Мпдели / Κωδικός προϊόντος / Πηλη / รุ่นผลิตภัณฑ์ / 產品模型 / 製品レファレンス番 / 제품명 / مرجع المنتج الكامل / مرجع كامل محصول

Retailer name & address: / Nom et adresse du vendeur / Nombre y dirección del minorista / Nome e endereço do revendedor / Nome e indirizzo delnegozio / Name und Anschrift des Händlers / Naam en adres van de dealer / Forhandler navn & adresse / Återförsäljarens namn och adress / Forhandler navn og adresse / Jälleenmyyjän nimi ja osoite / nazwa i adres sprzedawcy / Numele și adresa vânzătorului / Parduotuvės pavadinimas ir adresas / Müüja kauplus ja aadress / Naziv in naslov trgovine / Tipusszám / Názov a adresa predajcu / Veikala nosaukums un adrese / Naziv / Naziv a adresa malprodaje / Naziv a adresa prodavca / Naziv i adresa prodajnog mjesta / Nume și adresă vânzător / Název a adresa prodejce / Nama dan alamat peruncit / Nama Toko Penjual dan alamat / Tên và địa chỉ cửa hàng bán/ Satıcı firmanın adı ve adresi / Название и адрес прџдавца / Назва i адреса прџдавця / Търговския пбект / Назив и адреса на прџдавницата / Сатушының аты және мекен-жайы / Επωνυμία και διεύθυνση καταζητήματος / Ὑπερμνηστική πηλησφνηστική ή ημερομηνία / ชื่อและที่อยู่ของห้าง/ร้านที่ซื้อ / 零售商的店名和地址/販売店の名前、住所/소매점 이름과 주소 / نام و آدرس خرده فروش / اسم وعنوان بائع التجزئة

Distributor stamp Cachet distributeur /Sello del distribuidor / Carimbo do revendedor / Timbro del negozio / Händlerstempel / Stempel van de dealer / Forhandler stempel / Återförsäljarens stämpel / Forhandler stempel / Jälleenmyyjän leima / pieczęć sprzedawcy / Ștampila vânzătorului / Antspaudas / Tempel / Žig trgovine / Eladó neve, címe/ Razítko predajcu / Zímogs / Pečat malprodaje/ Pečat prodavca / Pečat prodajnog mjesta / Ștampila vânzătorului/ Razítko prodejce/ Cap peruncit / Cap dari Toko Penjual / Cửa hàng bán đóng dấu/ Satıcı Firmanın Kaşesi / Печать прџдавца / Печатка прџдавця / Печат на търговския пбект / Печат на прџдавницата / Сатушының мөрі / Σθραγίδα καταζητήματος / Ὑπερμνηστική ήηλησφνηστική / ตราประทับของห้าง/ร้านที่ซื้อ / 零售商的蓋印 / 販売店印 / 소매점 직인 / فروش مهر خرده / ختم بائع التجزئة

EN 2 - 19