

# General Manual



## Automatic Greasing System **Twin-3**

EG1703P04



*Your efficiency is our Challenge!*

## ***General information***

Type of manual	General Manual
System	Automatic Greasing System Twin-3
Document number	EG1703P04
Date of issue	September 2011
Revision	04

All rights reserved. No part of this manual may be copied and/or published by means of printing, photocopying, microfilm or by any other means without prior written permission from Groeneveld. This applies also to the drawings and diagrams appended.

Groeneveld reserves the right to change parts at any time, without prior or direct notice to the customer. The contents of this manual may also be changed without prior notice.

This manual applies to the standard version of the product. Groeneveld cannot accept liability for any damage arising from the use of specifications other than that supplied.

You are requested to contact Groeneveld technical service for information concerning adjustment, maintenance work or repairs that is not described in this manual.

Whilst this manual has been prepared with the greatest possible care Groeneveld cannot accept responsibility for any errors of the consequences of such errors.

## Table of Contents

Preface	5
1. General information	6
1.1. Introduction	6
1.2. The Twin automatic greasing system	6
2. Principle of operation	8
2.1. Introduction	8
2.2. Greasing cycle	8
2.2.1. Greasing cycle A	8
2.2.2. Greasing cycle B	9
2.3. Twin pump unit	10
2.3.1. Control unit	11
2.3.2. 5/2 way valve	14
2.3.3. Relief valve	14
2.3.4. Test push button	14
2.3.5. Grease reservoir and its follower plate	15
2.3.6. Minimum level switch	15
2.4. Distribution block and metering units	16
2.4.1. Principle of operation	17
2.5. Pressure switch	19
2.5.1. Principle of operation	19
2.6. Signal lamp	21
2.7. Duty mode push-button	21
2.8. Twin-3 display	22
2.8.1. Decimal dot of the 3-digit display	23
3. System test	24
3.1. Introduction	24
3.2. Single greasing cycle test	25
3.3. Multiple greasing cycle test	26
3.4. Fast automatic cycle session	27
3.5. Resetting the system	27
4. Maintenance	28
4.1. General	28
4.2. Periodic checks	28
4.3. Bleeding the pump	28
4.4. Bleeding the system	29
4.5. Refilling the grease reservoir	30
4.5.1. Grease recommendations	30
4.5.2. Filling the reservoir	30
4.6. Finding malfunctions	31
4.6.1. General	31
4.6.2. Recognizing malfunctions	31
4.6.3. Malfunction finding table	32
4.6.4. Retrieving a fault code message by signal lamp	40
4.6.5. Malfunction finding procedures	41
5. Technical data	44
5.1. Twin pump unit	44
5.2. Signal lamp	45
5.3. Twin display	46



## Preface

This general manual gives a description of the Twin automatic greasing system. It aims at giving insight in the system's operation and possibilities. Furthermore, in this manual you will find the technical data on several components of the Twin automatic greasing system.

In this manual the following icons are used to inform or warn the user:



### ATTENTION

Draws the user's attention to important additional information meant to avoid problems.



### WARNING

Warns the user for physical injuries or serious damage to the equipment caused by improper actions.

### Use of symbols

<i>Symbol</i>	<i>Explanation</i>
BK	Black
BN	Brown
BU	Blue
GN	Green
GY	Grey
OR	Orange
PK	Pink
PS	Pressure Switch
PU	Purple
RD	Red
WH	White
YE	Yellow

# 1 General information

## 1.1 Introduction

With an automatic greasing system of *Groeneveld* all grease points of a vehicle or machine are lubricated automatically at the correct moment and with the correct amount of grease. Because greasing takes place while the vehicle or machine is in operation, the applied grease is spread optimally over the whole surface to be greased. The greasing system requires no user intervention to operate, apart from periodically replacing the grease in its reservoir.

*Groeneveld's* automatic greasing systems are designed with the utmost care and tested rigorously. This guarantees an extended operational life and error-free operation, even under the most extreme operating conditions.

Proper installation, using the correct type of grease, and periodic checks are prerequisites for the continual hassle-free operation of the system. The periodic checks, which take little time and effort, can be performed during the normal maintenance of the vehicle or machine (during oil-replacement, for instance). Careful selection of construction materials, makes the greasing system itself nearly maintenance-free.



### ATTENTION

The automatic greasing system reduces the time and effort spent on manual greasing significantly. However, do not forget that there may be grease points that are not served by the greasing system and must still be greased by hand.

## 1.2 The Twin automatic greasing system

*Groeneveld* has developed a double-line automatic greasing system especially for the use of NLGI class-2 grease. The Twin system ensures that all the disadvantages of the systems currently available for class-2 grease are eliminated.

The Twin system has all advantages of the *Groeneveld* single-line systems. This means, for instance, that the system is expandible trouble-free with grease points that are installed afterwards (extra machine equipment).

The advantages of the Twin system:

- ingenious and fast assembly;
- modular expansion possible;
- parts of the system can (temporarily) be coupled or uncoupled;
- clear malfunction reports;
- registration of possible malfunctions;
- the grease dosage can easily be adjusted per greasing point to the needs of that particular greasing point;
- the grease dosage per greasing point remains constant under all circumstances.

A *Groeneveld* Twin automatic greasing system comprises the following parts (see Figure 1.1):

1. An electric grease pump (plunger pump) with integrated grease reservoir and a digital control unit with data storage facility
2. Primary grease line A
3. Primary grease line B
4. Distribution block
5. Metering unit
6. Pressure switch
7. Secondary grease line

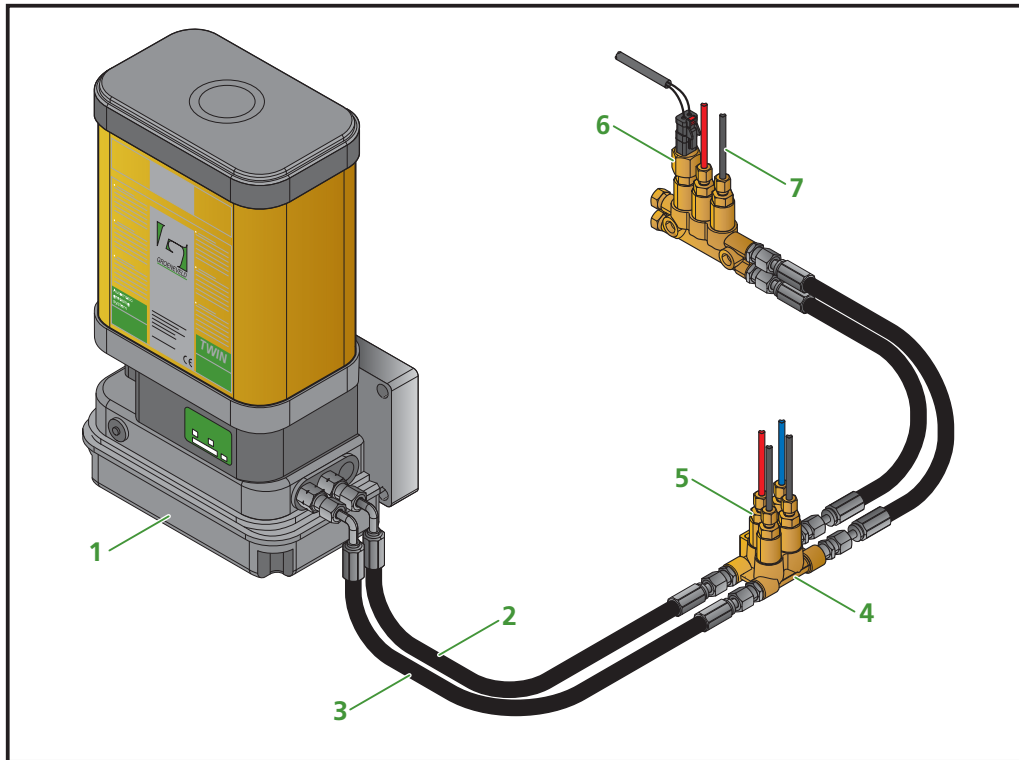

Figure 1.1 System overview

## 2 Principle of operation

### 2.1 Introduction

In this chapter the principles of operation of the various parts of the Twin automatic greasing system are discussed. The greasing cycle, pump unit, control unit, metering units, pressure switch, signal lamp and Twin-3 display are discussed.

### 2.2 Greasing cycle

Every greasing cycle consists of four phases. The greasing cycles are performed alternately by the grease lines-A and -B (see Figure 2.1). The 5/2-way valve, which is integrated in the pump housing, determines which primary grease line is connected to the pump and which is connected to the grease reservoir. The total greasing cycle has a predetermined time; the length of the four phases depend on the circumstances. The different greasing cycles and phases are discussed below.

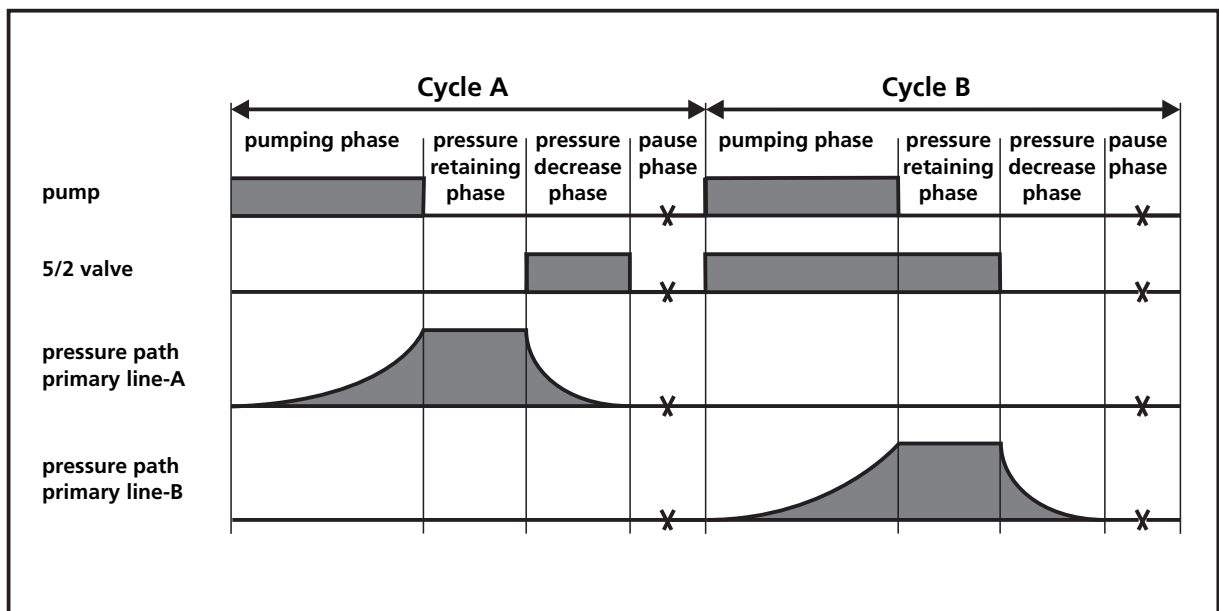

Figure 2.1 Overview of the various phases of the greasing cycle

#### 2.2.1 Greasing cycle A

##### Pumping phase

The greasing cycle begins with a pumping phase. In this phase the grease is pumped from the reservoir, through primary grease line-A, to the distribution blocks. The pumping phase ends when the pressure at the pressure switch reaches a predetermined level. The time needed to reach that predetermined pressure depends on various factors as temperature, grease consistency (thickness) and the dimensions of the greasing system.

During the pumping phase, the metering units press a certain amount of grease (the dosage) through the secondary grease lines to the grease points.



### Pressure retaining phase

The pressure retaining phase follows the pumping phase; a period in which the pressure in the primary grease line-A is maintained at a certain pressure. During the pressure retaining phase, the metering units can deliver the grease dosage, which (for various reasons) was not yet delivered during the pumping phase. The duration of the pressure retaining phase depends on the duration of the pumping phase. This dependency is expressed in the parameter *vmf*, venting multiply factor. Example: When the *vmf* is 1.0 the pressure retaining phase is the same length as the pumping phase. When the *vmf* is set to 10.0, the pressure retaining phase is 10 times the length of the pumping phase.

### Pressure decrease phase

The pressure decrease phase follows the pressure retaining phase. In this phase, the pressure in the primary grease line-A is decreased through the 5/2-way valve. To accomplish this, the control unit switches the 5/2-way valve on, so the grease pressure in the primary grease line-A is decreased and the grease flows back to the reservoir.

The duration of the pressure decrease phase is equal to that of the pressure retaining phase and therefore proportional to the duration of the pumping phase. When the greasing system needs more time to build up the required grease pressure (because of low temperature or grease with a high viscosity), the system will also need more time to decrease that same pressure.

### Pause phase

The pause phase is the period between the pressure decrease phase and the beginning of the next pumping phase in line-B. The length of the pause phase is equal to the predetermined cycle-time minus the length of the other phases. When the cycle-time is adjusted too short to perform a complete greasing cycle, the program will ignore the cycle-time. The pumping-, pressure retaining and pressure decrease phase will be performed completely. However the pause phase will be omitted, because the predetermined cycle-time is exceeded. The greasing system begins directly with the first phase of the next greasing cycle.

## 2.2.2 Greasing cycle B

Greasing cycle B begins when the pause phase of the former cycle A is finished. The control unit restarts the pump. During pumping phase B and pressure retaining phase B, the control unit switches the 5/2-way valve on, causing the pump to be connected to primary grease line-B. The primary grease line-A is shut off from the pump during these phases and connected to the reservoir. During the pressure decrease phase in primary grease line-B, the control unit switches the 5/2-way valve (spring return) off, so the grease pressure in the primary grease line-B decreases and the grease flows back to the reservoir.

### 2.3 Twin pump unit

The Twin pump unit consists of various parts. These parts are shown in Figure 2.2.

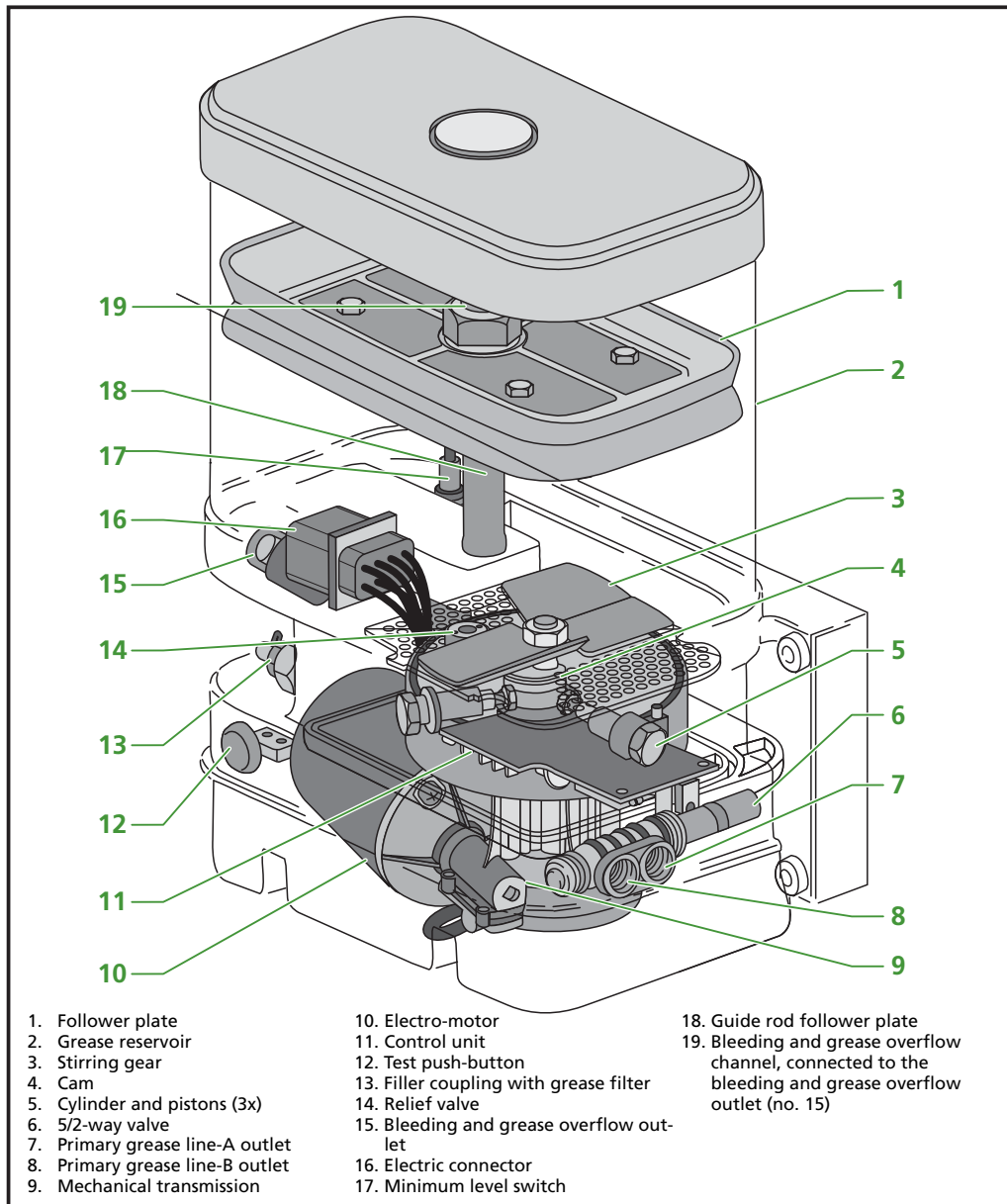

Figure 2.2 Twin pump unit

The heart of the pump is an electrical-driven piston-pump. This pump consists of three radially-placed fixed cylinders and pistons (5). The electromotor drives the axle through the mechanical transmission (9). A cam (4) is fixed on the axle that moves the three pistons to and fro, so the grease is pumped to the distribution blocks through the primary grease lines. In addition to the cam, the axle drives the stirring gear (3) located at the bottom of the reservoir and pushes the grease downwards. A compression channel is located between the pump and the grease channels to the primary lines. A relief valve (14) and a 5/2-way valve (6) are located in the compression channel.

The relief valve is a protection that leads the grease back to the reservoir when the grease pressure exceeds 250 bar. The 5/2-way valve determines the primary grease line-A or -B through which greasing takes place. It has an important task in fulfilling the four phases of the greasing cycle (see paragraph 2.2).

### 2.3.1 Control unit

The electronic control unit steers and controls the course of the greasing cycles. All system- and program-parameters are stored in it. The control unit processes malfunction reports, gives possible alarm reports and automatically records a log. All relevant incidents will be stored in the log.

All data in the control unit will always be retained, even when the power or system is switched OFF. To view the log an Uni- or PC-GINA is needed.

The control unit is electrically connected according to the wiring diagram shown (see Figure 2.3). The positive pole of the supply voltage (+15) is connected to pin-1.

As soon as the ignition is switched ON, the program cycle is started at the point where it was interrupted during the preceding cycle.

If the preceding cycle was interrupted during the pumping phase by switching OFF ignition, this pumping phase will be continued the moment ignition is switched ON again.

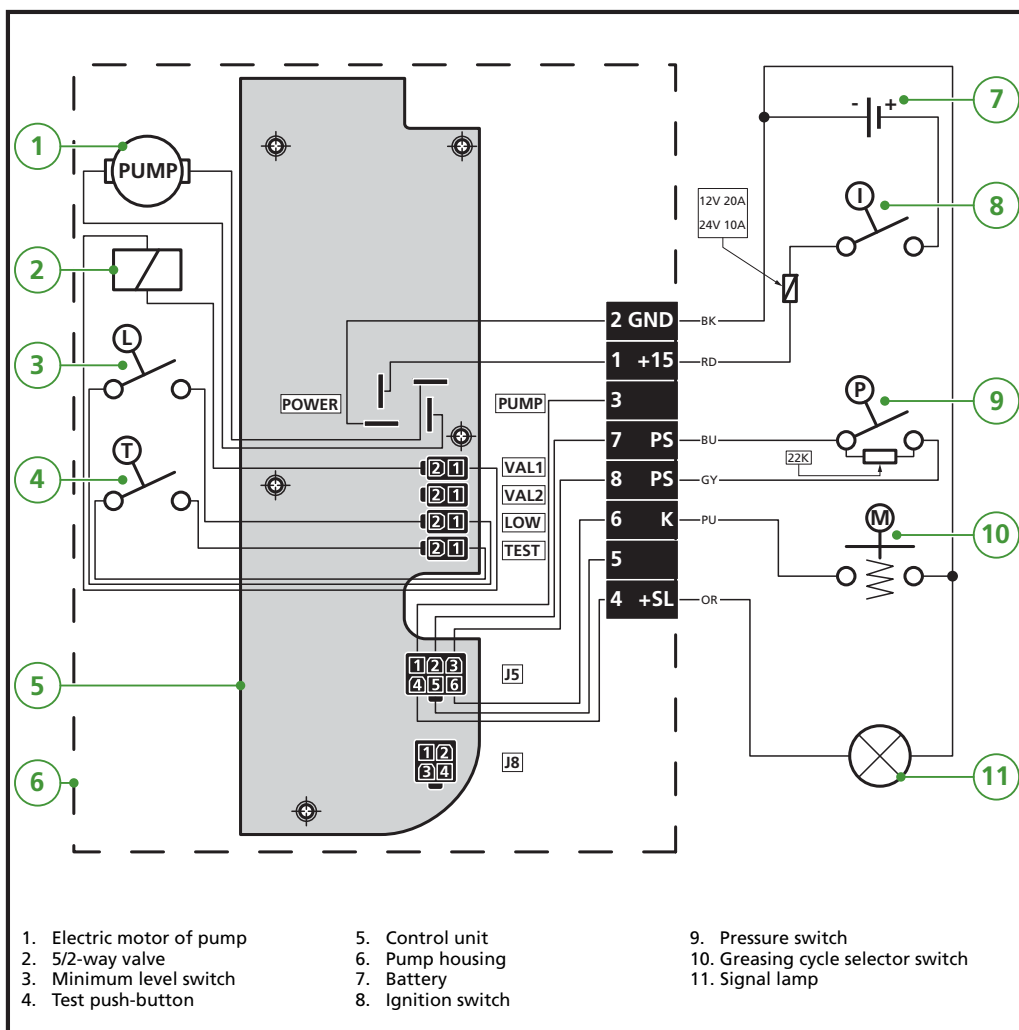

Figure 2.3 Wiring diagram with signal lamp

Date of issue : September 2011

Vehicles or machines of which the actual operation time is much shorter than the ignition time, the connected grease points could easily get over greased. In order to prevent this, the interval timer can be stopped for the time the vehicle or machine is not in operation, while the ignition is switched ON. Figure 2.4 shows how to connect the control unit in this situation.

Pin-1 and -2 are, as in the other diagram, connected to ignition and ground. Pin-3 is the additional connection for starting or stopping the interval timer on demand. Depending on the available electrical connection at the vehicle or machine, the interval timer can be started when:

- power to pin-3 is switched ON
- power to pin-3 is switched OFF
- ground to pin-3 is switched ON
- ground to pin-3 is switched OFF

Please refer to the Twin-3 Uni- or PC-GINA manual for the necessary parameter settings in order to activate one of the above mentioned possibilities.

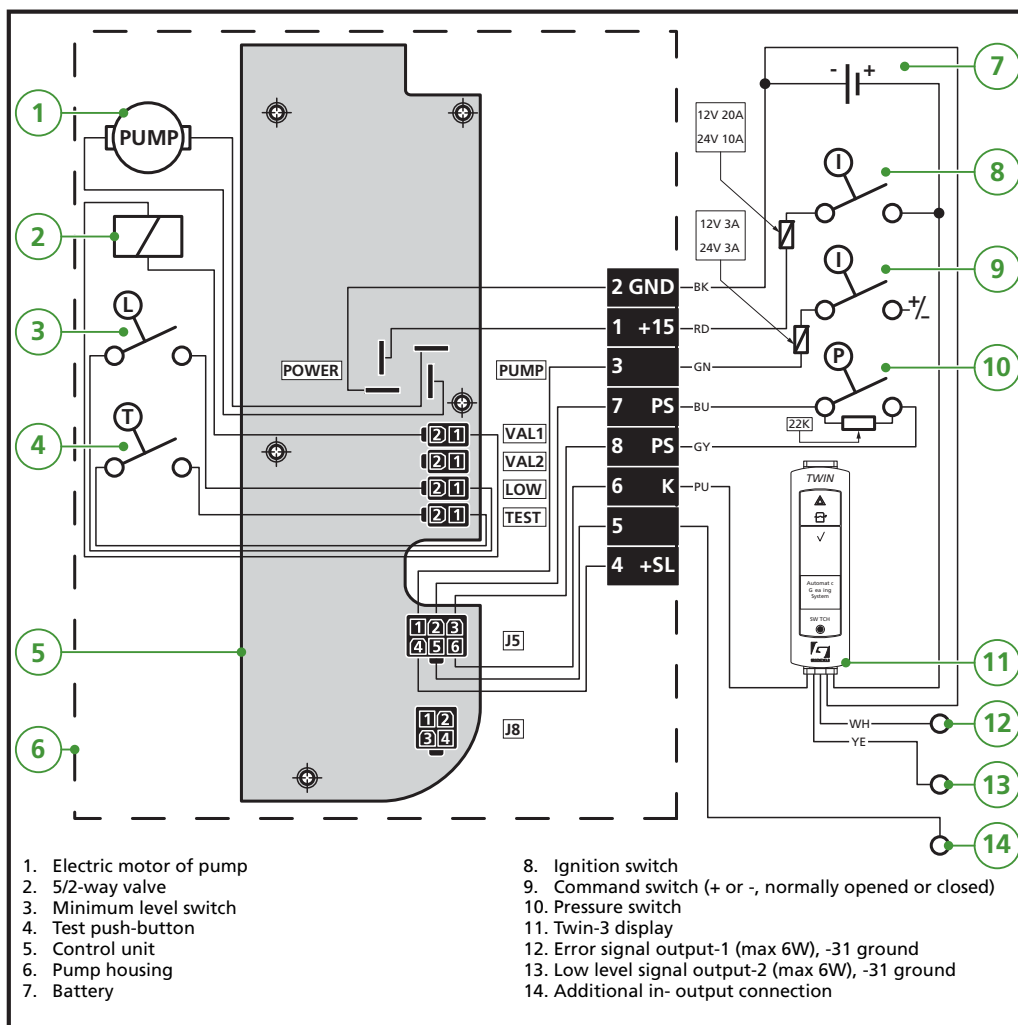

Figure 2.4 Wiring diagram with command switch and Twin-3 display

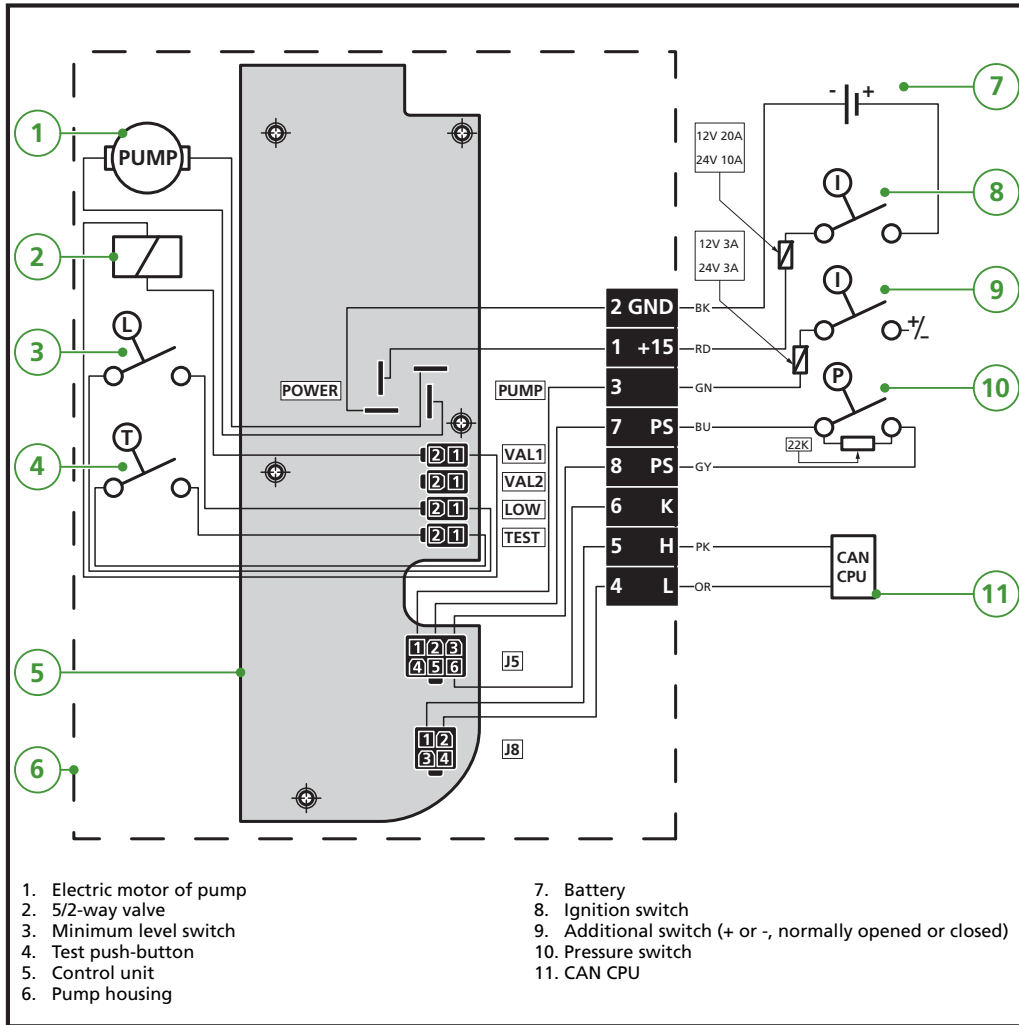

Figure 2.5 Wiring diagram OEM pump with CANbus



**IMPORTANT**

The internal wiring of an OEM/CANbus pump is different from standard. Activating the CANbus option in the control unit with a diagnosis device therefore will only be useful in combination with such a pump (see internal wiring of pump connector pin-4 and -5).

### 2.3.2 5/2 way valve

When the 5/2-way valve is at stationary (not switched on by the control unit, see Figure 2.6), greasing will take place through primary grease line-A and the pressure in primary grease line-B will decrease and the grease will be lead back to the reservoir through return line R<sub>B</sub>.

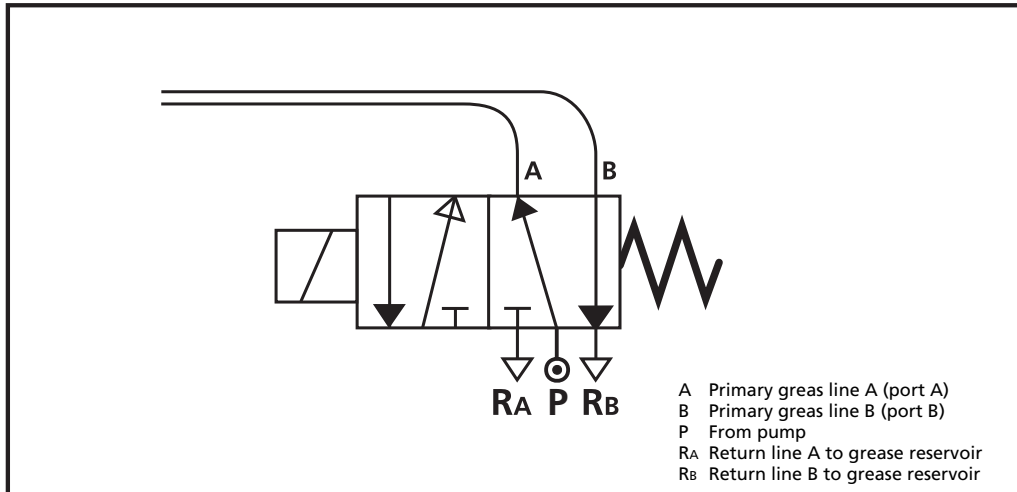

Figure 2.6 5/2-way valve

When the 5/2-way valve is switched on by the control unit, the grease supply channel P will be connected to primary grease line-B and primary grease line-A will be connected to return line R<sub>A</sub> in the pump. Greasing takes place through primary grease line-B, the pressure in primary grease line-A will decrease and the grease will be lead back to the reservoir through return line R<sub>A</sub>.

For an extensive description of the greasing cycle and the influence of the position of the 5/2-way valve on the greasing cycle, see paragraph 2.2.

### 2.3.3 Relief valve

A relief valve is mounted in the grease line between the piston-pump and the 5/2-way valve (see Figure 2.2/14). When the grease pressure exceeds 250 bar during the pumping phase, the relief valve will redirect the grease to the reservoir.

The maximum grease pressure will be exceeded when:

- a malfunction of the pressure switch, which is mounted in the system, occurs;
- a malfunction in the cable of the pressure switch occurs.

The pressure switch is intended to end the pumping phase, as soon as the minimum required grease pressure is reached.

### 2.3.4 Test push button

The grease system can be tested by starting one or more cycles by means of the test push-button on the pump unit (see Figure 2.2/12). This button also can be used to reset the control unit.

### 2.3.5 Grease reservoir and its follower plate

The reservoir (see Figure 2.2/2) is made of a transparent, impact-proof plastic that resists the affect of variable temperatures and other enviromental influences.

The volume of the reservoir depends on its height. The maximum grease level is indicated on the reservoir. A warning signal in the cabin indicates when the minimum level has been reached.

A follower plate (see Figure 2.2/1) is located in the reservoir, above the grease. This piston follows the level of the grease. When the grease level falls, the piston also falls under the influence of a draw spring. The grease follower plate locks out air and condensation, so preventing:

- oxidation of the grease;
- mingling of the grease with the water of condensation;
- saponifying of the grease.

The grease level in the reservoir can always be determined at a glance, because the grease follower plate scrapes the walls of the reservoir. Also the follower plate prevents funnel-forming in the grease, so the grease supply can and will be used in its entirety.

### 2.3.6 Minimum level switch

A minimum level switch monitors the grease level in the reservoir (see Figure 2.2/17). When the grease reaches the minimum level, this switch will notify the control unit. At the beginning of every following greasing cycle a signal lamp in the cabin will flash or the yellow and green LED along with indication LO at the Twin-3 display is lit continuously as a warning that the reservoir has to be refilled.

## 2.4 Distribution block and metering units

Various types of metering units with the Twin greasing system are available, each with a different grease output. Each grease point can receive the correct dose of grease per greasing cycle by a careful choice of the type of metering unit.

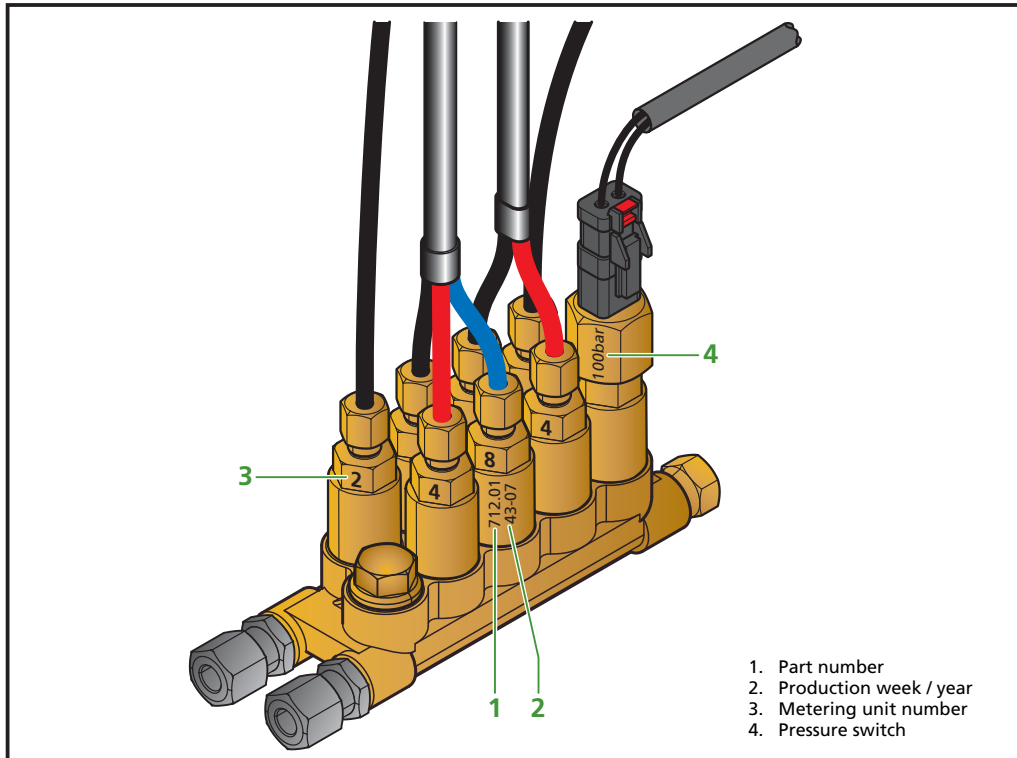

Figure 2.7 Distribution block with metering units

The metering units are mounted on a distribution block per group. The distribution blocks are deliverable with 2, 3, 4, 5, 6, 7, 8, 9, 12, 14, 18, 20, 21 or 22 ports (exits). Grease points are connected to these ports through metering units and secondary grease lines. Unused ports are sealed with a blind plug. A pressure switch can also be mounted into one of the ports.

Because of their closed construction the metering units are exceptionally well suitable for use in dirty and dusty environment.

The metering units and distribution blocks are made of brass or stainless steel. The various metering units are distinguished from each other using numbers (see Figure 2.7/3). The table below is an overview of the various metering unit numbers and their grease capacity.

Metering unit number	Grease capacity (cm <sup>3</sup> ) per cycle	Metering unit number	Grease capacity (cm <sup>3</sup> ) per cycle
0	0,025	7	0,350
1	0,050	8	0,400
2	0,100	8,5	0,700
3	0,150	9	1,000
4	0,200	10	2,000
5	0,250	11	4,000
6	0,300		



### 2.4.1 Principle of operation

Two grease chambers are located in a metering unit (one for each primary grease line, A and B). These chambers are filled with an exact amount of grease. When the actual greasing takes place through one of both chambers, the grease is pressed from the chambers to the relevant grease point. The principle of operation of the metering unit is explained in the four phases below.



#### ATTENTION

Do not open the metering units. Prevent intrusion of dirt and thus a possible cause of malfunction.

#### Phase 1

In this phase the metering unit has not yet been filled with grease.

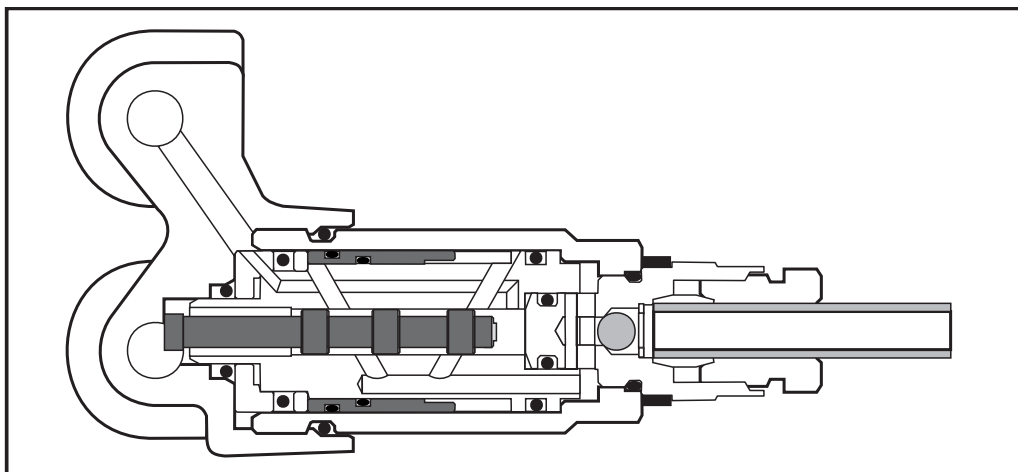

Figure 2.8 First phase

While in operation (system completely filled with grease) phases 3 and 4 will take place alternately.

#### Phase 2

During pumping phase A grease is pressed into channel A. While the grease pressure is built up, piston (3) is pushed to the right, passed channel (1). The grease fills chamber (2) through channel (1) and pushes piston (4) to the right.

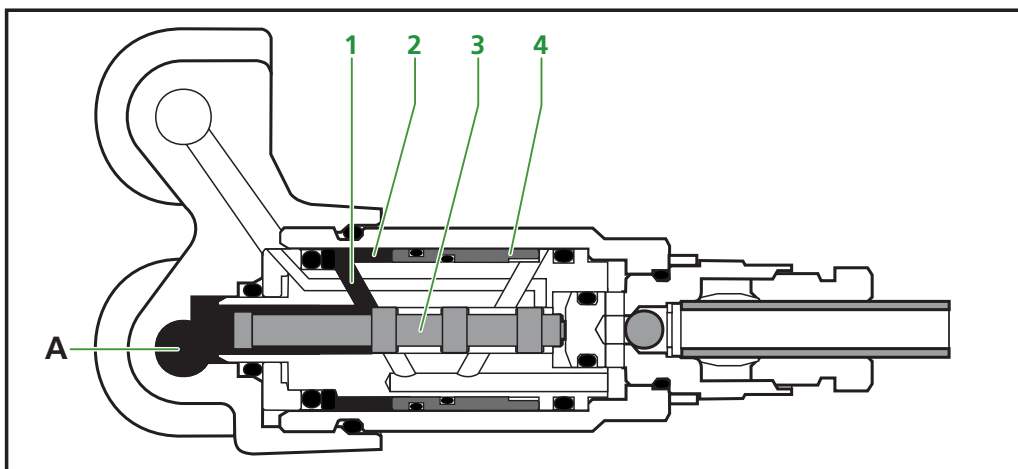

Figure 2.9 Second phase

After a while, the pressure drops in the primary grease line-A (during the pressure decrease phase of the greasing cycle). This has no influence on the metering unit.

**Phase 3**

During pumping phase B grease is pressed into channel B (6). While the grease pressure is built up, piston (3) is pushed back leftwards, passed channel (8). The grease fills chamber (7) and pushes piston (4) back to the left. The complete grease volume of chamber (2), left of piston (4), is pressed through channel (1), piston (3), channel (9) and the secondary grease line (5) to the grease point. Sphere (10) in the non-return valve is pushed back to clear the path to the secondary grease line.

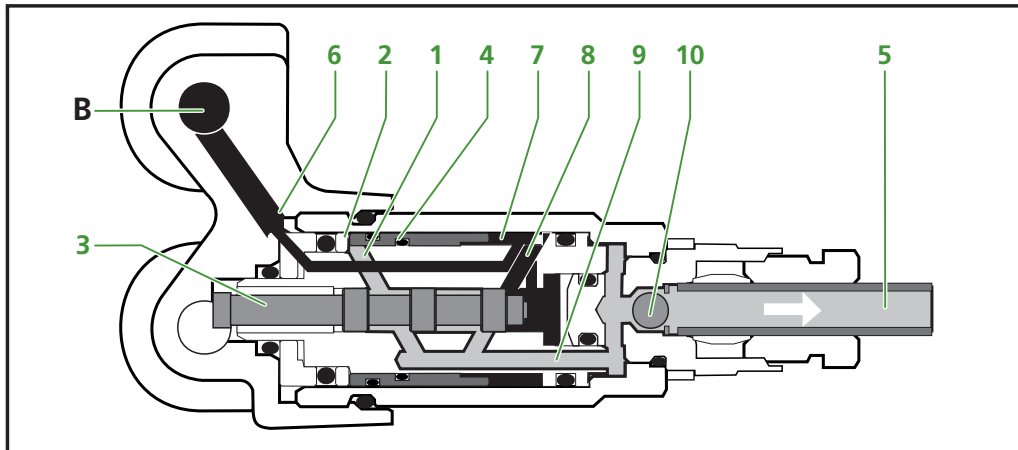

Figure 2.10 Third phase

After a while, the pressure drops in the primary grease line-B (during the pressure decrease phase of the greasing cycle). This has no influence on the metering unit.

**Phase 4**

In this phase the same happens as in phase 2. However chamber (Figure 2.10/7) is now filled with grease. Piston (4) is pushed to the right while chamber (2) is filled. The complete grease volume of chamber (Figure 2.10/7) is pressed through channel (8), piston (3), channel (9) and the secondary grease line (5) to the grease points. Sphere (10) in the non-return valve is pushed back to clear the path to the secondary grease line.

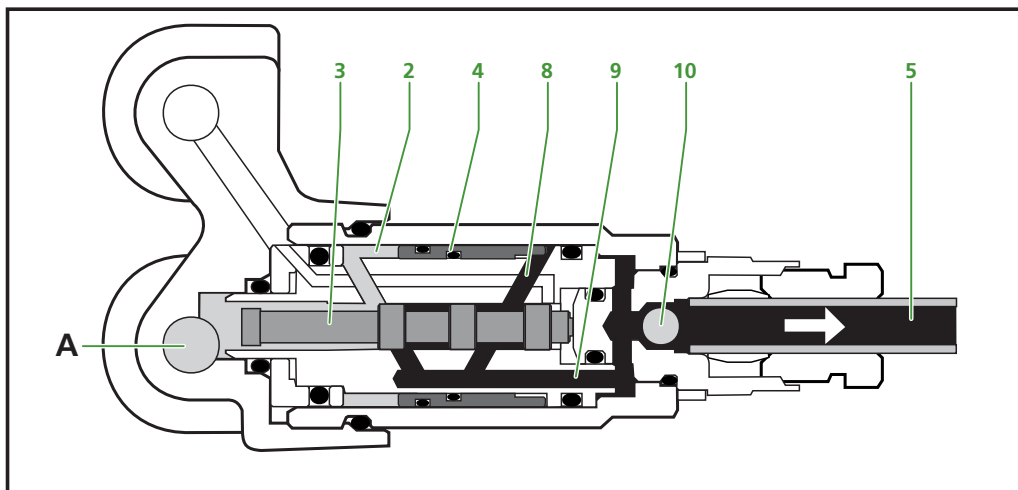

Figure 2.11 Fourth phase

## 2.5 Pressure switch

The pressure switch notifies the control unit that sufficient pressure has been built up during the pumping phase and stops the pump. When the required pressure is not reached, the pumping phase is only ended after reaching the set maximum pumping time. An alarm will follow (signal lamp).

Preferably the pressure switch is mounted on the distribution block, located the farthest from the pump. This is done to be sure that the required grease pressure of 100 bar also reaches the last distribution block. When for practical considerations the switch is placed somewhere in the middle or at the beginning of the greasing system, a switch with a higher switch-pressure is applied. Pressure switches are delivered with switch-pressures of 100, 125, 150 or 175 bar.

### 2.5.1 Principle of operation

The principle of operation of the pressure switch is explained in three phases.

#### Phase 1

During this phase no pressure is on channel A and B. There is also no pressure in chamber (1). Spring (10) pushes switch piston (2) to the left. The electrical contact (3 and 4) is open.

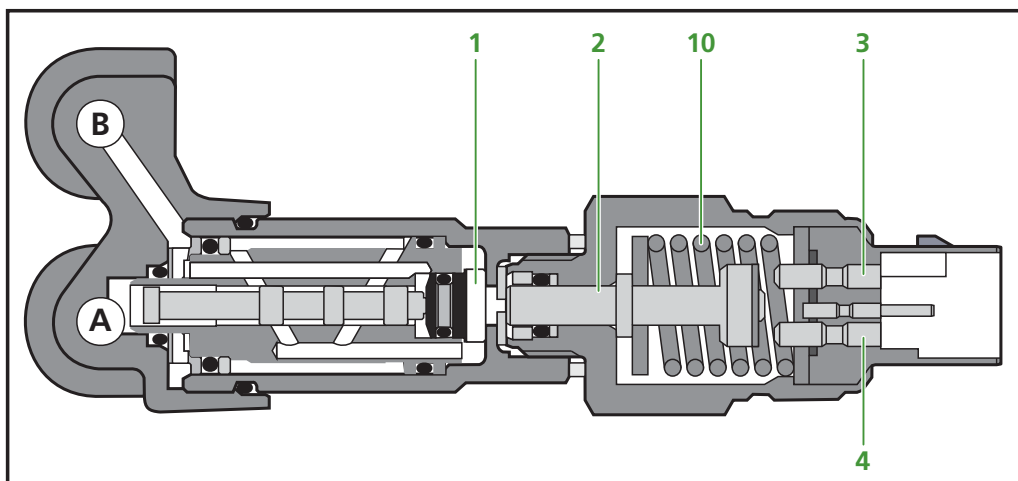

Figure 2.12 First phase

#### Phase 2

During pumping phase A grease is pressed into channel A. While the grease pressure is built up, piston (6) is pushed to the right. Chamber (1) is connected to channel A (through the channels 7, 8 and 9).

As soon as the pressure in chamber (1) is more than the pressure force of the spring (10), piston (2) goes to the right. The electrical contact (3 and 4) is closed by the contact plate (5).

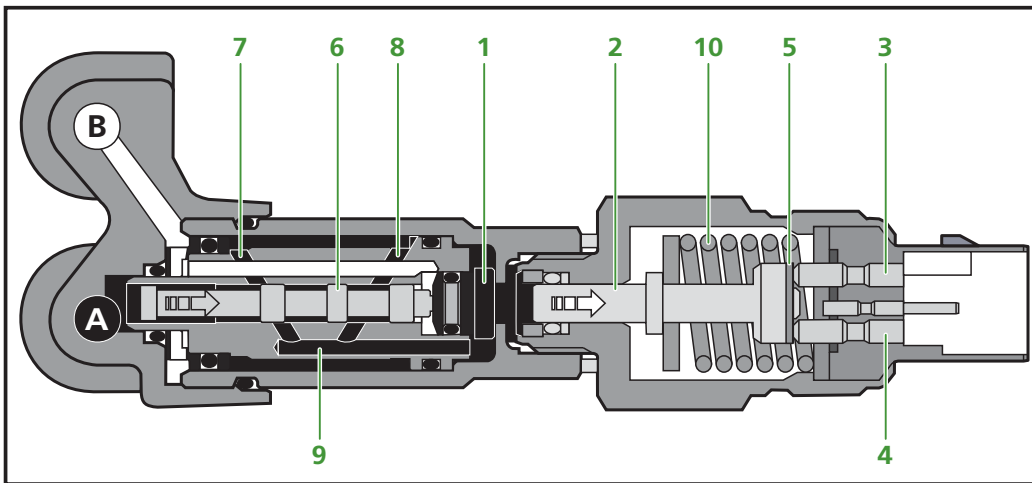

Figure 2.13 Second phase

During the pressure decrease phase, as soon as the grease pressure in channel A is lower than the pressure force of the spring, the connection of the electrical contacts is broken.

### Phase 3

During pumping phase B grease is pressed into channel B. While the grease pressure is built up, chamber (11) fills with grease (through channel 12). The grease pressure pushes piston (6) to the left. Because of that the channel (8) is opened, causing the grease to flow to chamber (1) through channel (7 and 9).

As soon as the pressure in chamber (1) is higher than the pressure force of the spring (10), the piston (2) goes to the right. The electrical contact (3 and 4) is closed by the contact plate (5).

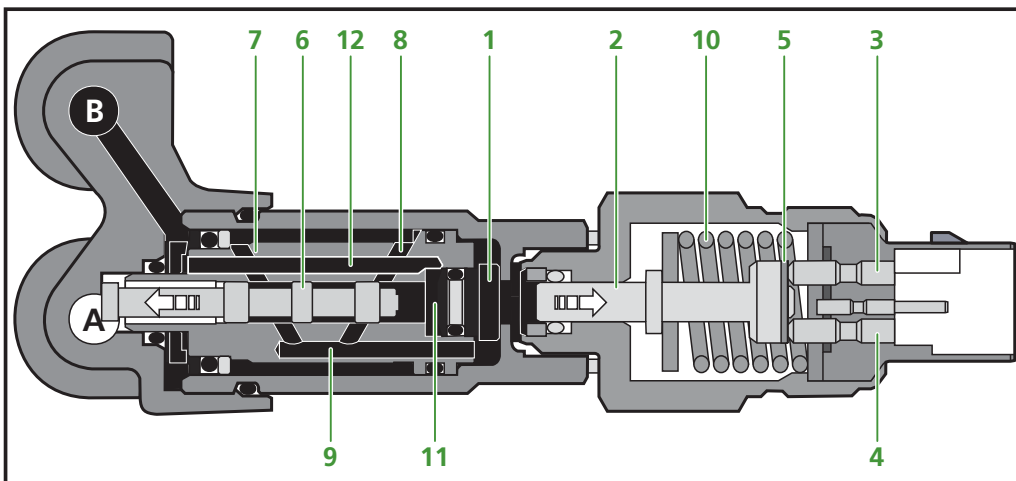

Figure 2.14 Third phase

During the pressure decrease phase, as soon as the grease pressure in channel B is lower than the pressure force of the spring, spring (10) pushes piston (2) back to the left and the connection of the electrical contacts is broken.

## 2.6 Signal lamp

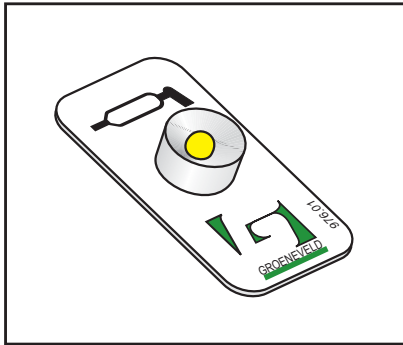

Figure 2.15 Signal lamp

The signal lamp is mounted in the field of vision of the driver and out of direct sunlight, because of the visibility of the signals. Possible this lamp can be combined with the operating push-button. The lamp shows the status of the greasing system and malfunction reports by means of flashing codes. In the table below, an overview of normal signals is given. Malfunction signals are in the fault finding table (see page 32).

Signal	Explanation								
Lamp flashes (0,5-sec. on/0,5-sec. off) as soon as the ignition has been switched ON.	<table border="0"> <tr> <td><i>Code</i></td> <td><i>Selected duty mode</i></td> </tr> <tr> <td>4x once</td> <td>Heavy</td> </tr> <tr> <td>4x twice</td> <td>Medium</td> </tr> <tr> <td>4x three times</td> <td>Light</td> </tr> </table> <p>Default this flash code is shown 4 times with 4 second intervals (the number of flash codes can be altered with a parameter setting).</p>	<i>Code</i>	<i>Selected duty mode</i>	4x once	Heavy	4x twice	Medium	4x three times	Light
<i>Code</i>	<i>Selected duty mode</i>								
4x once	Heavy								
4x twice	Medium								
4x three times	Light								
Lamp flashes during one complete cycle (2,0 sec. on/2,0 sec. off)	Single greasing cycle being executed. See paragraph 3.2.								
Lamp flashes continuously (0,2 sec. on/0,2 sec. off)	Multiple greasing cycle being executed. See paragraph 3.3.								



### ATTENTION

On request the lamp functionality can be inverted (parameter setting option). When activated, the lamp operates the other way around; Lamp switched ON where normally OFF and switched OFF where it used to be ON.

## 2.7 Duty mode push-button



Figure 2.16 Mode push-button with signal lamp

The duty mode push-button is mounted in the cabin of vehicles that have to operate under very various circumstances (e.g. earth moving machinery). The button is combined with the signal lamp. The driver can adjust the greasing intensity (greasing frequency), depending on the circumstances in which the vehicle or machine is used. The operating mode of the greasing system can be adjusted for light, medium or heavy duty. The push-button influences the length of the pause phase.

It is also possible to retrieve the fault codes on the signal lamp by using the duty mode push-button (see paragraph 4.6.4).

Proceed as follows to change the active duty mode:

1. Switch ignition ON;
2. Depress the push-button once (heavy duty), twice (medium duty) or three (light duty) times for 1 second;
3. The lamp will indicate the new selected interval.

## 2.8 Twin-3 display

With the switch-button (1) the desired operating/test mode can be selected and also errors can be reset (see Figure 2.17). The Twin-3 display is equipped with a 3-digit display (2). Herewith errors, the active duty mode and test mode (if applicable) can be displayed. The decimal dot (3) indicates whether the interval timer remains or is on standby (see paragraph 2.8.1). The green LED (4) indicates that the system is activated. The yellow LED (5) indicates when the minimum grease level has been reached. The red LED (6) indicates a malfunctioning.

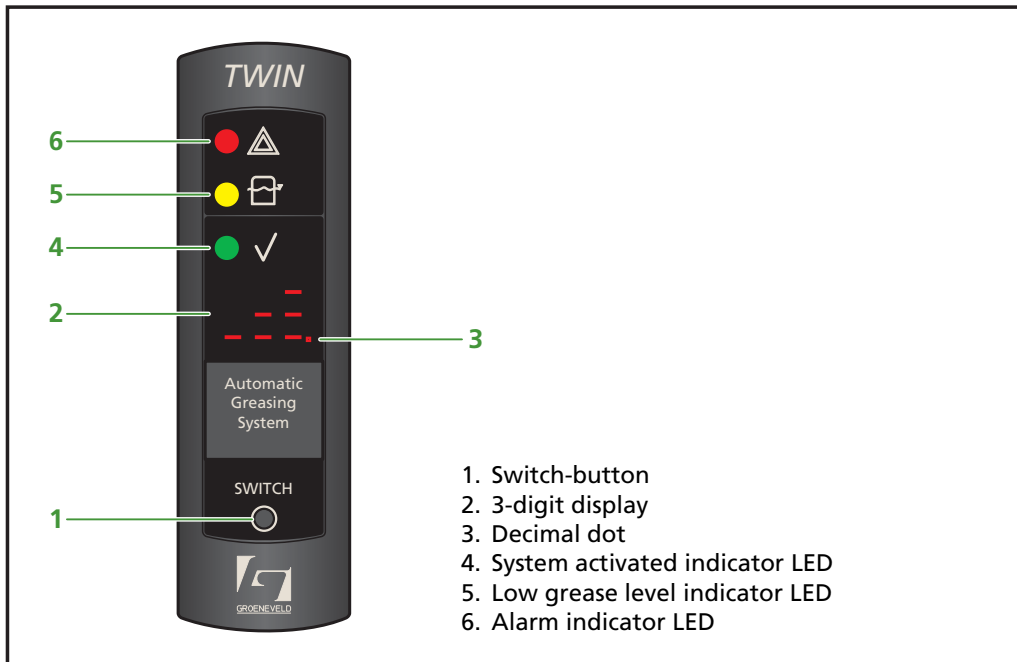

Figure 2.17 Twin-3 display

Proceed as follows to change the active duty mode:

1. Switch ignition ON;
2. Push the switch-button for at least 5 seconds.  
Accordingly, the 3-digit display starts flashing;
3. Push the switch-button repeatedly until the desired duty mode shows;
4. Leave the desired duty mode flashing for at least 6 seconds until the duty mode comes on.  
This will confirm the desired duty mode has now changed.



### IMPORTANT

Do NOT switch OFF ignition when the desired duty mode still flashes. Otherwise, when ignition is switched OFF prior to duty mode coming on, the change will be ignored and old duty mode appears again.

In the table below is shown an overview of display indications.

Indication	Explanation
	When ignition is switched ON the 3-digit display forms an rotating clock indicating it's communication with the pump control unit. After 10 seconds the preset duty mode selection appears along with the green LED.
	Light duty - Greasing mode with long intervals. (Decreased greasing output)
	Medium duty - Greasing mode with medium intervals. (Normal greasing output)
	Heavy duty - Greasing mode with short intervals. (Increased greasing output)
	*Pump performs a single cycle test (LED flashes slow). (See paragraph 3.2).
	*Pump performs multiple cycle test (LED flashes fast). (See paragraph 3.3).
	Pump performs a number of fast automatic cycles. (See paragraph 3.4).
	When the pump is performing fast automatic cycles (without pressure retaining, pressure decrease and pause phase), the display alternates (every 5 seconds) between T3 and the number of remaining cycles. (In this case '047').
	*Minimum level in the reservoir has been reached. Resets itself by refilling the reservoir.
	System error. Duty cycle selection possible only after the error has been solved. (See "Malfunction reports of Twin-3 display" on page 34).

\*) Indication shown when a Twin-3 display has been connected to a Twin-2 pump.

**NOTE**

The display is equipped with a light-sensitive cell. Therefore the light intensity of the LED's is automatically dimmed when the surroundings become darker. Annoying reflections in screens of the cabin are reduced to a minimum.

**2.8.1 Decimal dot of the 3-digit display**

Indication	Explanation
	Decimal dot lights up - Interval timer stop Decimal dot flashes - Interval timer run
	Decimal dot running Pump phase active (incl. pressure retaining and pressure decrease phase)

## 3 System test

### 3.1 Introduction

To test the greasing system two different cycle tests can be performed with the test push-button on the pump or with switch-button at the Twin-3 display (see Figure 3.1 and Figure 3.2):

1. The single cycle test (through line-A or -B).
2. The multiple cycle test (continuous cycles through line-A and -B).

A cycle test can only be performed if the greasing system is performing the pressure retaining phase, the pressure decrease phase or the pause phase.



#### NOTE

When the system is already performing a pumping phase, the system will not respond when the test push-button or switch-button is pushed.

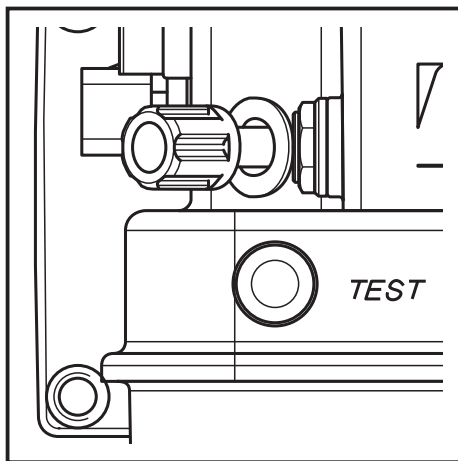

Figure 3.1 Test push-button (pump)

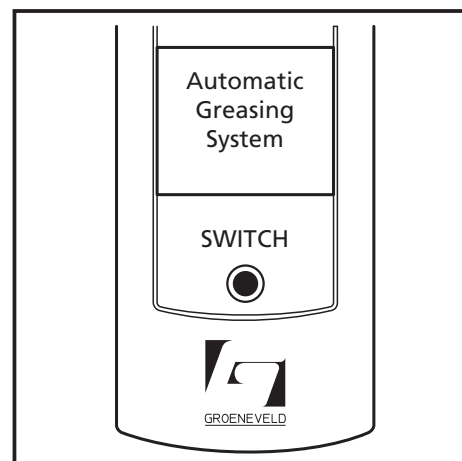

Figure 3.2 Switch-button (Twin-3 display)

The signal lamp or the green LED at the display flashes during the cycle test(s). In case of a single cycle it will flash slowly (2-sec. on / 2-sec. off) and code "T1" will show at Twin-3 display. In a multiple cycle test it will flash rapidly (0,2-sec. on / 0,2-sec. off) and code "T2" will show at Twin-3 display. Only the signal lamp will light continuously for 2 minutes in the end of each failed cycle test. After the pump has been disabled due to a number failed cycles in succession the display will show the initial cause by means of an fault code (see paragraph 4.6.4). This code can also be visualized by the signal lamp (see paragraph 4.6.3).

Errors that occurred during the test cycles are not stored in the control unit records.



#### ATTENTION

Only use the cycle test if necessary. Every time a cycles test is performed, grease is added to the grease points. This is at the expense of the grease volume and can lead to excessive greasing of the grease points.



### 3.2 Single greasing cycle test

In order to check the system, perform a single greasing cycle as follows:

1. With the test push-button at pump:
  - a. Switch ignition ON;
  - b. Push the test push-button at pump for 2-6 seconds.  
The system will operate a single greasing cycle.  
During the operation the green LED at Twin-3 display or signal lamp at the duty mode push-button will flash slowly (2-sec. on / 2-sec. off).  
A code "T1" and a running-decimal-dot will be indicating its pump, pressure retaining and pressure decrease phase at Twin-3 display;
  - c. When the single greasing cycle is finished, the pump reverts to automatic mode and shows its active duty mode at Twin-3 display or signal lamp at the duty mode push-button will go off.
  
2. With the switch-button at Twin-3 display:
  - a. Switch ignition ON;
  - b. Push the switch-button at least for 5 seconds.  
Accordingly, the 3-digit display starts flashing;
  - c. Push the switch-button repeatedly until code "T1" shows;
  - d. Leave the code "T1" flashing until the code comes on.  
The system will operate a single greasing cycle. (See also next alinea).  
During the operation the green LED at Twin-3 display will flash slowly (2-sec. on / 2-sec. off).  
A code "T1" and a running-decimal-dot will be indicating its pump, pressure retaining and pressure decrease phase at Twin-3 display;
  - e. When the single greasing cycle is finished, the pump reverts to automatic mode and shows its active duty mode and green LED comes on.

The single cycle test ends after the pressure decrease phase or when the ignition is switched OFF. When the ignition is switched ON again the program will always begin with the pause phase of the cycle that has just been interrupted.



#### ATTENTION

Remember that a single cycle test only tests one of the primary grease lines. To test the other primary grease line, a second single cycle test has to be performed.

### 3.3 Multiple greasing cycle test

In order to provide additional grease to all grease points i.e. after cleaning the vehicle or to purge the system, perform a multiple greasing cycle as follows:

1. With the test push-button at pump:
  - a. Switch ignition ON;
  - b. Push the test-button at pump for more then 6 seconds.  
The system will operate a multiple greasing cycle.  
During the operation the green LED at Twin-3 display will flash quickly (0,2-sec. on / 0,2-sec. off).  
A code "T2" and a running-decimal-dot will be indicating its pump, pressure retaining and pressure decrease phase at Twin-3 display;
  - c. The multiple greasing cycle can be finished by simply switching ignition OFF.
  
2. With the switch-button at Twin-3 display:
  - a. Switch ignition ON;
  - b. Push the switch-button at least for 5 seconds.  
Accordingly, the 3-digit display starts flashing;
  - c. Push the switch-button repeatedly until code "T2" shows;
  - d. Leave the code "T2" flashing until the code comes on.  
The system will operate a multiple greasing cycle. (See also next alineas).  
During the operation the green LED at Twin-3 display will flash quickly (0,2-sec. on / 0,2-sec. off).  
A code "T2" and a running-decimal-dot will be indicating its pump, pressure retaining and pressure decrease phase at Twin-3 display;
  - e. The multiple greasing cycle can be finished by simply switching ignition OFF.

The system will start a pumping phase. After pumping phase A, pressure retaining phase A and pressure decrease phase A are ended, pumping phase B is started immediately, then again A, then B, etc. The pause phases are skipped entirely every time.



#### ATTENTION

It is also possible to skip the pressure retaining phase and pressure decrease phase during the multiple cycles test, by activating the "enable fast multiple test" option with an Uni- or PC-GINA (see parameter menu).

Please be aware that when activated at low temperatures, the output of the metering units in the end of the system might get reduced to 0, due to these missing phases.

When the ignition is switched ON again the program will always begin with the pause phase of the pumping phase that has just been interrupted.

### 3.4 Fast automatic cycle session

An fast automatic cycle session can be triggered when the connected bearings need additional grease fast (i.e. after install or after system repair). During such a session a pre-defined number of greasing cycles are executed and accelerated by skipping pressure retaining, pressure decrease and pause phases.



#### ATTENTION

Please be aware that when executed at low temperatures, the output of the metering units in the end of the system might get reduced to 0, due to these missing program phases.

A fast automatic cycle session can only be initiated with the use of an Uni- or PC-GINA. Please refer to the Twin-3 Uni- or PC-GINA manual.

During the session the display alternates (every 5 seconds) between "T3" and the number of remaining cycles.

Once triggered, this session cannot be ended by switching OFF ignition like with a Multiple test. The moment ignition is switched ON again, the pump resumes the session until all pre defined cycles are finished.

The fast automatic cycle program can be ceased by the following actions:

1. With the test push-button at the pump:
  - a. Activating a single cycle test.
  - b. Activating a multiple cycle test.
2. With the use of an Uni- or PC-GINA:
  - a. Change the preset amount of fast automatic cycles to "0" in parameters.
  - b. Select either Auto (F1), Single test (F3) or Multiple test (F4).

When during the session a number of cycles fail in succession, the session ends and pump disables. The Twin-3 display will show the red LED and the cause by error code (see "Malfunction reports of Twin-3 display" on page 34). All data during such a session will be stored as fast automatic cycles and successful finished cycles.

### 3.5 Resetting the system

When the system has failed to operate and diagnostics has lead to a successful resolvment, the system needs a reset in order to revert to its automatic operation mode.

Perform a reset as follows:

1. With the test push-button at pump;
  - a. Push the test push-button at pump for 1 second.  
Twin-3 display will revert to its active duty mode and green LED comes on or signal lamp at the duty mode push-button will go off.
2. With the switch-button at Twin-3 display;
  - b. Push the switch-button at least for 5 seconds.  
Twin-3 display will revert to its active duty mode and green LED comes on.

### 4 Maintenance

#### 4.1 General

The maintenance of *Groeneveld's* Twin greasing systems can be combined with the normal maintenance of the vehicle or machine.



#### WARNING

When cleaning the vehicle or machine with a high-pressure water/steam jet cleaner, the pump of the greasing system should not be directly exposed to the jet. This to prevent water from entering the pump through its de-aerating opening. During normal operation, however, water will never be able to enter the pump.



#### ATTENTION

The automatic greasing system reduces the time and effort spent on manual greasing significantly. However, do not forget that there may be grease points that are not served by the greasing system and must still be greased by hand.

#### 4.2 Periodic checks

1. Check the grease level in the reservoir and its condition. Do not fill the reservoir until the low level warning comes on at the Twin-3 display or on the signal lamp of the duty mode push-button switch;
2. Check the functionality of the Twin-3 display or duty mode push-button with signal lamp;
3. Check if the selected duty mode is applicable to working conditions of the vehicle;
4. Check the pump for damage and leakage;
5. Check the primary and secondary lines for damage and leakage;
6. Check the condition of the grease points served by the system. Sufficient fresh grease should be present;
7. Check system operation. Perform a single grease cycle test;
8. Clean the pump and its surroundings;
9. Replace or clean the internal pump filter every 500 hrs (vehicle operating/driving hours). The filter is located behind the external filler coupling beneath the reservoir;
10. Check the stored data in the control unit with the use of an Uni- or PC-GINA.

#### 4.3 Bleeding the pump

When the system malfunctions repeatedly due to an empty grease reservoir, it is possible that the pump needs to be bled.

Proceed as follows:

1. Make sure that the grease reservoir is filled.



#### WARNING

Check that the system is pressureless, before opening the system.

2. Remove both primary lines from the pump.
3. Switch ignition ON.
4. Push the test push-button at the pump for at least 6 seconds (multiple cycle test).
5. Switch ignition OFF as soon as pure grease (without air-pockets) comes from one of the pump outlets.



### NOTE

When after a few minutes still no grease exits the pump outlet we advise to pump some oil into the reservoir along the filler-coupling (500 cc or 1/8 gallon will be sufficient). This will help to push aside the air-pockets around the pump piston.

The oil can also be pumped into the reservoir along grease outlet B, but than first the pump need to be stopped by switching ignition OFF.

6. Re-mount the primary lines to the pump.
7. Perform a single cycle test twice to check if the system functions correctly.
8. When pressure build up in the system is still insufficient it is possible that also the primary lines need to be bled (see paragraph 4.4).
9. To make sure that the pump is still in good condition also the grease pressure could be measured with a manometer, direct at one of the pump outlets. During a pumping phase the pressure should reach 230-250 bar and is not allowed to fall below 200 bar during the successive "pressure retaining phase".



### NOTE

Install a pressure gauge of minimum 250 bar along with 1-meter high pressure hose (HPH) onto the pump outlet. The 1-meter HPH allows additional contents of grease to cancel out small pressure fluctuations.

## 4.4 Bleeding the system

When the system malfunctions repeatedly due to an empty grease reservoir, it is possible that one (or both) primary line(s) need(s) to be bled.

Proceed as follows:

1. Make sure that the grease reservoir is filled.



### WARNING

Check that the system is pressureless, before opening the system.

2. Remove the end plugs from the distribution blocks that are at the end of each branch in the system.
3. Switch ignition ON.
4. Push the test push-button at the pump for at least 6 seconds (multiple cycle test). Because the end plugs are removed, no grease pressure is built up. When the maximum pumping time has past, the system switches automatically to the other primary line. This is repeated until the ignition is switched OFF.
5. Switch ignition OFF as soon as pure grease (without air-pockets) comes from the primary lines.
6. Re-mount the end plugs into the distribution blocks.
7. Repeat step 4, 5 and 6 until all branches of the system are bled.
8. Perform a single cycle test twice to check that the system functions correctly.

## 4.5 Refilling the grease reservoir

### 4.5.1 Grease recommendations

Grease should not contain graphite or PTFE. The use of correct grease in the Twin-3 system is of utmost importance. The use of grease with a maximum of 5% molybdenum disulphide (MoS2) is permitted.

Groeneveld recommends the use of its GreenLube grease.

Consult your local Groeneveld dealer prior to change of grease (specifications) or any other inquiries you may have.

The Twin greasing system is developed for use with grease up to NLGI-class 2. Which NLGI-class has to be used, mainly depends on the temperature in which the greasing system has to operate:

<i>Minimum operating temperature of the system</i>	<i>Maximum operating temperature of the system</i>	<i>Prescribed NLGI Grade</i>
-20°C / -4°F	+70°C / +158°F	2
< -20°C / -4°F	0°C / +32°F	0 / 1
< -20°C / -4°F	+70°C / +158°F	Synthetic 2
< -20°C / -4°F	0°C / +32°F	Synthetic 0 / 1

### 4.5.2 Filling the reservoir

If the yellow LED and LO code at Twin-3 display lights up continuously or the signal lamp at the duty mode push-button flashes for 2 minutes (0,5 sec. on/0,5 sec. off) at the start of each cycle, the minimum grease level in reservoir has been reached. In this case the reservoir requires a refill as follows:

1. When a new fillerpump or hose is used, ensure no air is left in it. Prime fillerpump and hose to avoid air-pockets being pumped into Twin-3 pump reservoir;
2. Remove the dust cap from the filler coupling;
3. Carefully clean the filler coupling and coupling on the filler hose used;
4. Fix the filler hose on the filler coupling;
5. Fill the reservoir up to maximum level indicated on the reservoir;
6. The bottom of follower plate should line up with max. level mark;
7. Remove the filler hose and fit the dust cap;
8. Fix the filler hose on filler coupling of the fillerpump, in order to keep the filler hose clean.



**NOTE**

The yellow LED and LO code at Twin-3 display or signal lamp of duty mode push-button will go OFF automatically when pump reservoir has been refilled.



**NOTE**

Do not fill the reservoir until the low level warning comes on at the Twin-3 display or on the signal lamp of the duty mode push-button switch.



**NOTE**

It is possible that during or directly after the refilling, some grease comes from the bleeding opening of the pump (left side).

When pumping is difficult, it is possible that the filler coupling or the filter behind this filler coupling at the pump is clogged. It is also possible that the filling coupling and the coupling of the filling hose are clogged. Remove the clogged parts and clean them. When the grease is cold, pumping can also become difficult. It is advised to store the grease in a heated environment in order to smoothen the filling.



### ATTENTION

Replace or clean the internal grease filter every 500 hrs (vehicle operating / driving hours).

When refilling is performed with a filling installation of a service station, it is recommended to clean or replace the filter behind the filling coupling on a regular basis (at least every 500 operational hours). This is because the pump of the refilling installation can easily break a clogged up filter while pumping. Because of this, dirt and pieces of the filter could get into the system which should be avoided in all circumstances.

If during the refilling process, air is pumped into the reservoir and accumulates under the grease follower plate, it can be removed by refilling the reservoir to just above the maximum level. Because of this, the air can escape directly under the grease follower plate through the bleeding channel in the grease follower plate guide. The bleeding channel is opened when refilling of the grease is done above the maximum level.



### NOTE

When refilling is just above the maximum level some grease can come from the bleeding opening of the pump (at the left side), because some grease can enter the bleeding channel in addition to air.

## 4.6 Finding malfunctions

### 4.6.1 General

The Twin greasing system is equipped as standard with an electronic control unit with a database. All relevant data concerning the functioning of the greasing system are stored in that database. This data can be read with the use of an Uni- or PC-GINA.

### 4.6.2 Recognizing malfunctions

Malfunctions are recognizable or discovered as follows:

- The signal lamp or all 3 LED's including 3-digit display no longer lights up when ignition is switched ON.
- The signal lamp or Twin-3 display shows a malfunction.
- Retrieving a fault code on the signal lamp by means of the duty mode push-button or fault codes are shown at Twin-3 display (see paragraph 4.6.3).
- Reading the malfunction reports saved in the database of the control unit.
- The grease level in the pump no longer decreases.
- When visually checking the bearings, it appears that no fresh grease collar is present.

### 4.6.3 Malfunction finding table

To make it easier to find malfunctions (when no Uni- or PC-GINA is available), refer to the malfunction finding table. In this table, probable causes of malfunctions and their solutions are listed. Because malfunction reports through the Twin display varies a little from the reports through the signal lamp, a separate table is inserted.

#### Malfunction reports of signal lamp

<i>Malfunction</i>	<i>Cause</i>	<i>Solution</i>
1. Lamp does not flash when the ignition has been switched ON.	<ul style="list-style-type: none"> <li>a. No supply voltage on pin 1.</li> <li>b. No ground wire connection with control unit or signal lamp (pin 2).</li> <li>c. Signal lamp broken.</li> <li>d. Wiring interruption between power supply and the control unit or between control unit and signal lamp.</li> </ul>	<ul style="list-style-type: none"> <li>a. Check fuse and replace if necessary.</li> <li>b. Check and repair earth ground wire connection if necessary.</li> <li>c. Replace signal lamp if necessary.</li> <li>d. Check and repair wires if necessary.</li> </ul>
2. Lamp flashes for 2 minutes (0,5-sec. on/ 0,5-sec. off) at the beginning of each cycle.	Minimum level in the reservoir has been reached.	Resets itself by refilling the reservoir.
3. Lamp continuously lit after the ignition has been switched ON.	<ul style="list-style-type: none"> <li>a. The last 10 greasing cycles failed. The control unit switched OFF the pump due to a number of failed cycles in succession in order to prevent possible environmental pollution in case of damaged hoses.</li> <li>b. Minimum level report in combination with no pressure in the system within the maximum pumping time.</li> </ul>	<ul style="list-style-type: none"> <li>a. Push the test push-button at the pump for 1 second to reset the report. Locate the cause of the malfunction and repair it (see point 4).</li> <li>b. Refill the reservoir to reset the malfunction report. Perform a system test and bleed the system if necessary.</li> </ul>



<i>Malfunction</i>	<i>Cause</i>	<i>Solution</i>
4. Signal lamp lights continuously for 2 minutes at the end of pumping phase.	<p>The state of the pressure switch did not change from open to closed. Possible causes:</p> <ul style="list-style-type: none"> <li>a. The primary grease line leaks. Because of this, no pressure can be built up.</li> <li>b. Air pocket in the system. Within the maximum pumping time insufficient pressure is built up.</li> <li>c. Broken pressure switch.</li> <li>d. O-ring damaged or left out when replacing a metering unit, pressure switch or blind plug, causing grease leakage from line-A to -B and vice versa.</li> <li>e. 5/2-way valve broken, preventing pressure build or release in primary line-A or -B. Because of this, no pressure can be built up or released.</li> <li>f. Internal leak of metering unit or pressure switch valve.</li> <li>g. Surrounding temperature too low or grease too viscose.</li> <li>h. Wiring defect or bad contacts.</li> <li>i. Other possible cause.</li> </ul>	<ul style="list-style-type: none"> <li>a. Replace or repair the line and vent the relevant line.</li> <li>b. Vent both primary lines and perform the multiple cycle test twice (See paragraph 3.3).</li> <li>c. See "Procedure to check pressure switch (valve) and its cable" on page 41.</li> <li>d. Check and mount a new O-ring if necessary. Also see "Procedure when an internal system leak is suspected" on page 43).</li> <li>e. See "Procedure to check pump and 5/2-way valve" on page 42.</li> <li>f. Replace the metering unit or pressure switch valve.</li> <li>g. Replace the grease in the reservoir and bleed the system.</li> <li>h. Check the wiring and contacts. Replace if necessary.</li> <li>i. Consult the dealer.</li> </ul>













**ATTENTION**





On request a divergent lamp functionality can be programmed, like:







- inverted lamp functionality (lamp is switched OFF, where normally switched ON).
- direct low-level indication on signal lamp (lamp activated for the entire period the level switch is activated and not only during the pumping phases).



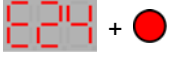

**Malfunction reports of Twin-3 display**

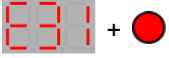

<i>Error code / malfunction</i>	<i>Cause</i>	<i>Solution</i>
<p>1. One or all LED's  and/or 3-digit display , does not light up partially or completely the moment ignition is switched on.</p>	<p>a. No supply voltage at the display. b. Ground wire disconnected. c. Display does not perform the self test but a single LED or the 3-digit display is broken. d. Defective display</p>	<p>a. Check fuses and/or wire connection (yellow wire). Repair when necessary. b. Check the ground wire (brown wire). Repair when necessary. c. Replace display. d. Replace display.</p>
<p>2.  Decimal DOT is lighted constantly (intervaltimer stop), while it is supposed to run (intervaltimer run).</p>	<p>a. The green command wire no. 3 is stopping the interval timer. b. The green command wire no. 3 is stopping the interval timer.</p>	<p>a. Check whether wire no. 3 for stopping the interval timer is connected correctly (see wiring diagram Figure 2.4 and that of the vehicle when available). Repair when necessary. b. Check with the use of an Uni- or PC-GINA whether the timer activation options are set correctly. Change these parameter settings when necessary.</p>
<p>3.  +  Successive no pressure in line-A</p>	<p>The pressure switch did not close during a greasing cycle in primary line-A. Possibly caused by:</p> <p>a. Broken/damaged primary line-A. b. Metering unit causes internal bypass. c. Air trapped into pump and or primary line-A.</p>	<p>a. Check condition of primary lines and its connectors. Replace or repair when necessary. b. Proceed with "Procedure when an internal system leak is suspected" on page 43. c1. Refill reservoir until reservoir is bled. See paragraph 4.5.2 "Filling the reservoir". c2. Bleed the pump and primary lines. Proceed with paragraph 4.3 &amp; 4.4 "Bleeding pump &amp; system".</p>

Error code / malfunction	Cause	Solution
<p>4.  +  Successive no pressure in line-B</p>	<p>The pressure switch did not close during a greasing cycle in primary line-B. Possibly caused by:</p> <ul style="list-style-type: none"> <li>a. Broken/damaged primary line-B.</li> <li>b. Metering unit causes internal by pass.</li> <li>c. Air trapped into pump and or primary line-B.</li> </ul>	<ul style="list-style-type: none"> <li>a. Check condition of primary lines and its connectors. Replace or repair when necessary.</li> <li>b. Proceed with "Procedure when an internal system leak is suspected" on page 43.</li> <li>c1. Refill reservoir until reservoir is bled. See paragraph 4.5.2 "Filling the reservoir".</li> <li>c2. Bleed the pump and primary lines. Proceed with paragraph 4.3 &amp; 4.4 "Bleeding pump &amp; system".</li> </ul>
<p>5.  +  Successive pressure before cycle in line-A</p>	<p>The pressure switch was still closed at the outset of a cycle in primary line-A. Possibly caused by:</p> <ul style="list-style-type: none"> <li>a. Damaged PS wiring harness to where wires are joined.</li> <li>b. 5/2-way valve did not operate correctly.</li> <li>c. Pressure switch failed/broken.</li> </ul>	<ul style="list-style-type: none"> <li>a. Check wiring and connectors. Replace or repair when necessary.</li> <li>b. Check 5/2-way valve and operate manually with the use of an Uni- or PC-GINA. Replace or repair when necessary.</li> <li>c. Check and or replace pressure switch (valve).</li> </ul>
<p>6.  +  Successive pressure before cycle in line-B</p>	<p>The pressure switch was still closed at the outset of a cycle in primary line-B. Possibly caused by:</p> <ul style="list-style-type: none"> <li>a. Interrupted PS wiring harness to where wires are joined.</li> <li>b. 5/2-way valve did not operate correctly.</li> <li>c. Pressure switch failed/broken.</li> </ul>	<ul style="list-style-type: none"> <li>a. Check wiring and connectors. Replace or repair when necessary.</li> <li>b. Check 5/2-way valve and operate manually with the use of an Uni- or PC-GINA. Replace or repair when necessary.</li> <li>c. Check and or replace pressure switch (valve).</li> </ul>

Error code / malfunction	Cause	Solution
<p>7.  Empty reservoir</p>	<p>Cycles that have not been performed, due to grease reservoir ran empty and disabled the pump, caused by:</p> <ul style="list-style-type: none"> <li>a. Max. number of cycles with an activated low level switch exceeded (with pump low level stop activation).</li> <li>b. A combination of an activated low-level switch and initial "no pressure line-A or -B" error, indicating the pump ran out of grease.</li> </ul>	<ul style="list-style-type: none"> <li>a. Refill the reservoir. Proceed with paragraph 4.5.2 "Filling the reservoir" procedure.</li> <li>b. Refill the reservoir. Proceed with paragraph 4.5.2 "Filling the reservoir" procedure. Thereafter, proceed with paragraph 4.3 "Bleeding the pump" procedure.</li> </ul>
<p>8.  Successive low supply voltage / bad wiring</p>	<p>Aborted cycles, due control unit encountered successive power dips in attempt to initiate pump motor, caused by:</p> <ul style="list-style-type: none"> <li>a. Faulty battery (vehicle)</li> <li>b. Faulty wiring (ground wire)</li> <li>c. Corroded pin-contact in connector</li> </ul>	<ul style="list-style-type: none"> <li>a. Charge or replace battery</li> <li>b. Check wiring. Replace or repair when necessary.</li> <li>c. Check connections at pump and in cabin. Replace or repair when necessary.</li> </ul>
<p>9.  Faulty pressure switch circuit</p>	<p>The pressure switch did not close during a greasing cycle in primary line-A or -B while control unit noticed a deviant resistance over the pressure switch circuit, caused by:</p> <ul style="list-style-type: none"> <li>a. Faulty wiring or connectors</li> <li>b. Defective pressure switch</li> </ul>	<ul style="list-style-type: none"> <li>a. Check wiring/connectors. Replace or repair when necessary, proceed with paragraph 4.6.5 "Malfunction finding procedures".</li> <li>b. Replace pressure switch.</li> </ul>
<p>10.  Successive pump open loads</p>	<p>Control unit detected a too low current draw to pump motor, in combination with initial "no pressure line-A or B" error, caused by:</p> <ul style="list-style-type: none"> <li>a. Interrupted wiring</li> <li>b. Defective motor</li> <li>c. Defective control unit.</li> </ul>	<ul style="list-style-type: none"> <li>a. Check wiring. Replace or repair when necessary.</li> <li>b. Check motor on wiring faulty, check the resistance of the motor. Replace when necessary.</li> <li>c. Check control unit. Replace or repair when necessary.</li> </ul>

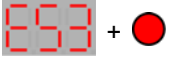
Error code / malfunction	Cause	Solution
11.  +  Successive pump over current	Control unit detected a too high current draw to pump motor and aborted the attempted cycle, caused by: <ul style="list-style-type: none"> <li>a. Short circuit in wiring of motor</li> <li>b. Short circuit in motor.</li> <li>c. Drive shaft blocked</li> <li>d. Extreme low working temperature in combination with a grease not suitable for these conditions.</li> <li>e. The "pump motor current limit" setting not suitable for the extreme low working temperature.</li> </ul>	<ul style="list-style-type: none"> <li>a. Check the wiring of motor. Replace or repair when necessary.</li> <li>b. Check motor on wiring faulty, check the resistance of the motor. Replace when necessary.</li> <li>c. Check the drive shaft on blocking. Replace or repair when necessary.</li> <li>d. Replace the grease in the reservoir and bleed the system with a suitable grease for the obtained working conditions.</li> <li>e. Increase the "pump motor current limit" parameter setting but only after checking whether the vehicle wiring and fuse can handle a higher setting.</li> </ul>
12.  +  Successive valve-1 open loads	Control unit detected a too low current draw to first coil of the 5/2-way valve in combination with initial "system on pressure before cycle" error, caused by: <ul style="list-style-type: none"> <li>a. Interrupted wiring of the coil</li> <li>b. Defective coil</li> </ul>	<ul style="list-style-type: none"> <li>a. Check wiring. Replace or repair when necessary.</li> <li>b. Check coil on wiring faulty, check the resistance of the coil. Replace or repair when necessary.</li> </ul>
13.  +  Successive valve-1 over current	Control unit detected a too high current draw to 5/2-way valve in combination with initial "system on pressure before cycle" error, caused by: <ul style="list-style-type: none"> <li>a. Short circuit in wiring of the coil</li> <li>b. Defective coil</li> </ul>	<ul style="list-style-type: none"> <li>a. Check wiring. Replace or repair when necessary.</li> <li>b. Check coil on wiring faulty, check the resistance of the coil. Replace or repair when necessary.</li> </ul>

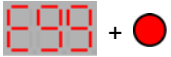
Error code / malfunction	Cause	Solution
14.  + ● Successive valve-2 open loads	Control unit detected a too low current draw to first coil of the 5/2-way valve in combination with initial "system on pressure before cycle" error, caused by: <ol style="list-style-type: none"> <li>Interrupted wiring of the coil</li> <li>Defective coil</li> </ol>	<ol style="list-style-type: none"> <li>Check wiring. Replace or repair when necessary.</li> <li>Check coil on wiring faulty, check the resistance of the coil. Replace or repair when necessary.</li> </ol>
15.  + ● Successive valve-2 over current	Control unit detected a too high current draw to 5/2-way valve in combination with initial "system on pressure before cycle" error, caused by: <ol style="list-style-type: none"> <li>Short circuit in wiring of the coil</li> <li>Defective coil</li> </ol>	<ol style="list-style-type: none"> <li>Check wiring. Replace or repair when necessary.</li> <li>Check coil on wiring faulty, check resistance of the coil. Replace or repair when necessary.</li> </ol>
16.  + ● Communication error with control unit	<ol style="list-style-type: none"> <li>No communication between display &amp; control unit</li> <li>No supply voltage at the pump</li> <li>Defective Twin-3 display</li> </ol>	<ol style="list-style-type: none"> <li>Check the purple communication wire no. 6 between display and pump (pump connector pin no. 6). Repair when necessary.</li> <li>Check the fuse and red power wire no.1 to pump connector no. 1 and the black ground wire no. 2 to the pump connector no. 2. Replace or repair when necessary.</li> <li>When no issues found as stated in solution A or B, replace display.</li> </ol>
17.  + ● Parameter checksum error	Control unit encountered corrupted parameters during power up and restored the production default settings.	Replace control unit.
18.  + ● Low RTC battery (real time clock battery) NOTE: 3V battery	Real time clock battery low (2,2 V) at the control unit.	Replace control unit.
19.  + ● RTC faulty	Control unit encountered a corrupted real time clock causing the events and errors to be stored with in accurate time & dates caused by: <ol style="list-style-type: none"> <li>RTC battery empty</li> </ol>	<ol style="list-style-type: none"> <li>Replace control unit.</li> </ol>

Error code / malfunction	Cause	Solution
20.  +  Unknown cause	Control unit encountered an unknown cause due to:  a. Display connected to a Twin-2 control unit (or a Twin-3 control unit with SW version 1063 or lower). Such a control unit does not supply additional info on the cause of the error like the Twin-3 pump does since SW version 1078  b. An error cause that is not listed in the table.	a. Replace control unit for one with a SW version 1078 or higher when the additional error information is required.  b. Replace control unit.

**General**

Malfunction	Cause	Solution
1. All grease points do not receive sufficient grease and no malfunction reports have been given.	a. The set greasing interval is too long for the application.  b. The interval clock does not run (wiring).  c. The interval clock does not run (parameter).	a. Choose the "heavy duty mode" with the switch-button and or shorten the interval period times in parameter section with the use of an Uni- or PC-GINA.  b. Check the interval clock command wiring and connection (green wire no. 3 / pump connector pin no. 3).  c. Check with the use of an Uni- or PC-GINA whether the "timer activation options" are set correctly.
2. All grease points are over greased.	The set greasing interval for the application is too short.	Choose the "low duty mode" with the switch-button and or increase the interval period times in parameter section with the use of an Uni- or PC-GINA.
3. One or more grease points do not show grease while the other points receive sufficient grease.	a. Squeezed or broken secondary grease lines.  b. Metering unit with lesser output than required.  c. Metering unit is defect.	a. Check and replace the relevant secondary line if necessary.  b. Mount metering unit with larger grease output.  c. Remove and clean the metering unit or mount a new one.
4. One or more grease points receive excessive amount of grease while the other points do receive the right amount of grease.	a. Metering unit with more output than required.  b. Metering unit with internal leak.	a. Mount a metering unit with less grease output.  b. Remove the metering unit and mount a new one.

Date of issue : September 2011

#### 4.6.4 Retrieving a fault code message by signal lamp

The fault message that caused the system to malfunction can be retrieved by pushing the duty mode push-button for at least 6 seconds (20-sec. max). Directly after releasing the push button the signal lamp will show the fault message by flash code (does not function with switch-button on display).



**ATTENTION**

Fault codes can only be retrieved when the pump communication line (pin/wire no. 6) is not connected to an Uni- or PC-GINA and need to be disconnected for at least 50 seconds before a code can be retrieved.

The signal lamp indicates the fault codes by flashing:

- Dozens are shown by long pulses (0,5 seconds)
- Units are shown by short pulses (0,15 seconds)

**Examples**

<i>Pulse</i>	<i>Fault code</i>
long, short, short, short, short	14
long, long, short	21

**Code that causes a pump to shut-off**

<i>Fault code</i>	<i>Meaning</i>
11	No pressure line-A
12	No pressure line-B
13	Pressure before cycle in line-A
14	Pressure before cycle in line-B
15	Empty grease reservoir
20	Low supply voltage or bad wiring
21	Pressure switch circuit error
22	Open load pump circuit
23	Over current pump circuit
24	Open load valve 1
25	Over current valve 1
31	Open load valve 2
32	Over current valve 2
99	An error cause, not listed in the table / Replace control unit.

**Code that do not cause a pump to shut-off**

<i>Fault code</i>	<i>Meaning</i>
10	Currently no errors available
51	Parameter checksum error
52	Clock battery low
53	Clock error



### 4.6.5 Malfunction finding procedures

A number of procedures to determine the correct cause of a certain malfunction are described below.

#### Procedure to check pressure switch (valve) and its cable

1. Disconnect the 2-pole connector from the pressure switch.
2. Measure the resistance between the two contacts using a digital multimeter. When the system is pressureless, the resistance should be 22K ohm. If required, remove the switch to make sure that no pressure below the pressure switch is present. Remove only the upper part, the diverter valve can be left in place.



#### ATTENTION

If a pressure switch without a resistor is being used in the greasing system you should measure an open load.

3. If possible, mount a pressure gauge that is suitable for a grease pressure up to 250 bar between the diverter valve and the pressure switch and bleed this connection before use.
4. Switch ignition ON.
5. Start a cycle test by pushing the test push-button at the pump.
6. Check the switching moment of the pressure switch using the digital multi-meter. When the adjusted pressure (see the side of the pressure switch) is reached the contact should be closed, the resistance should  $\pm 0$  ohm.
7. Switch ignition OFF for ending the cycle test.

If the pressure switch functions properly, the cable should be checked for internal damage.

8. Connect both contacts of the connector of the pressure switch with a separate wire.
9. Disconnect the pump connector.
10. Measure the resistance between pin 7 and 8 of the pump connector. The measured resistance should be  $\pm 0$  ohm.
11. Remove the wire between the contacts of the connector of the pressure switch. The digital multimeter should read an *open load*.

### Procedure to check pump and 5/2-way valve

1. Disconnect both primary grease lines from the pump outlet A and B.



#### WARNING

Check whether the system is pressureless before the system is opened!

2. Connect a pressure gauge to each channel of the pump. Use pressure gauges that are suitable for a grease pressure of 250 bar.
3. Switch ignition ON.
4. Push the test push-button at the pump for about 4 seconds to start a cycle test. The pump now pumps grease from one of the channels. The pressure reading of the gauge connected to this channel should raise to the maximum attainable pressure of 230 to 250 bar.



#### ATTENTION

The pump is not switched OFF by the pressure switch, because the greasing system is disconnected.

If the pump does not reach the indicated pressure, it has the following causes:

- Air lock in the grease (air bubbles). Disconnect the pressure gauge and let the grease flow until no more air bubbles come from the channel. If necessary, refill the reservoir with some oil to remove the air around the pumping element.
  - Temperature too low and or grease is too viscous. Therefore it is not sucked in by the pumping piston. Replace the grease in the reservoir and the primary grease lines by more suitable grease for the aimed temperature.
  - Pump is faulty. Replace the pump.
5. End the cycle test by switching the ignition OFF or by disconnecting the pump connector for a moment.
  6. Switch ignition ON.
  7. Start another cycle test with the test push-button at the pump; The pump should start in the other channel and the pressure gauge will quickly increase to the maximum adjusted grease pressure of 230 to 250 bar. The first channel should become de-pressurised.

When the pressure in the first channel does not drop and no pressure is built up in the other channel, the 5/2-way valve is faulty. Replace the valve or the entire pump.

8. End the cycle test by switching of the ignition or by disconnecting the pump connector for a moment.

### Procedure when an internal system leak is suspected

1. Disconnect the primary grease line of outlet B of the pump.



#### WARNING

Check whether the system is pressureless before the system is opened!

2. Switch ignition ON.
3. Push the test push-button at the pump for about 4 seconds to start a cycle test. The pump is started and pumps grease through one of the grease channels. If this is not channel A, break off the cycle test by switching the ignition OFF or by momentarily disconnecting the pump connector. Start another cycle test with the test push-button at the pump. The pump starts automatically in the other channel (A).

While the pressure in channel A builds up, some returning grease can come from the just disconnected grease line. However when grease keeps flowing from this line there is an open connection between both primary grease channels, most likely caused by a missing or damaged O-ring under one (or more) metering unit(s).

When a leak is established in the system, it has to be determined in which distribution block the leak is present.

4. Disconnect the primary grease line from block channel B, directly after the first distribution block after the pump.
5. Restart the pump in channel A.

When the grease leaks from outlet B of this first distribution block, the leak must be found in this block. When the grease leaks from the disconnected primary grease line, the leak must be sought farther down the system. Therefore repeat this procedure every time using the next distribution block until the leak is found.



#### NOTE

To determine which distribution block channel is connected to pump outlet A, you need to follow the primary grease line to the pump.

When there is only little leak, it may be impossible to establish the leak with the operating pump. Therefore, switch OFF the pump when the maximum pressure is reached. Switch ignition OFF or momentarily disconnect the pump connector. The pressure should be steady (minimum 200 bar; this procedure only works for channel A). The pressure may only drop when the control unit opens the valve, as soon as a new cycle test is started in channel B.

When there is a pressure drop, but there is no grease coming back, it indicates a leaking metering unit. Therefore check all connected grease points on an excessive grease collar indicating an internal leakage.

## 5 Technical data

### 5.1 Twin pump unit

Maximum operating pressure:	250 bar
Operating temperature:	-20...+70°C
Supply voltage:	12 or 24 Vdc
Rating pump motor with valve (nominal at 20°C):	72W
Control unit absorption:	40mA (12/24 Vdc)
Advised fusing:	10A (24 Vdc) 20A (12 Vdc)
Capacity grease reservoir:	2, 3, 4, 6 or 8 litres
Nominal grease output:	12 cm <sup>3</sup> / min
Grease follower plate:	standard
Minimum level switch:	standard
Pump material:	hard anodised aluminium - nylon reinforced
Protection class:	IP67
The Twin automatic greasing system complies to the electromagnetic compatibility requirements of:	Automotive directive 72/245/EC, as last amended by directive 2006/28/EC Earth Moving Machinery standard; ISO 13766 (1999)

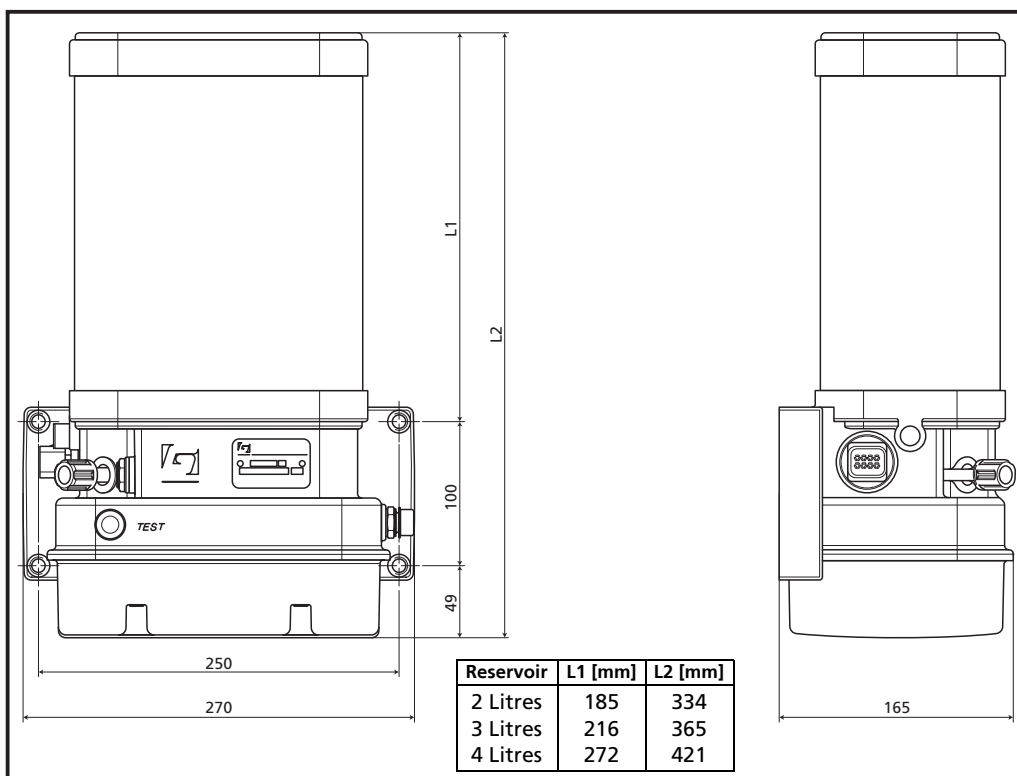

Figure 5.1 Dimensions Twin pump with a 2, 3 or 4 litre reservoir

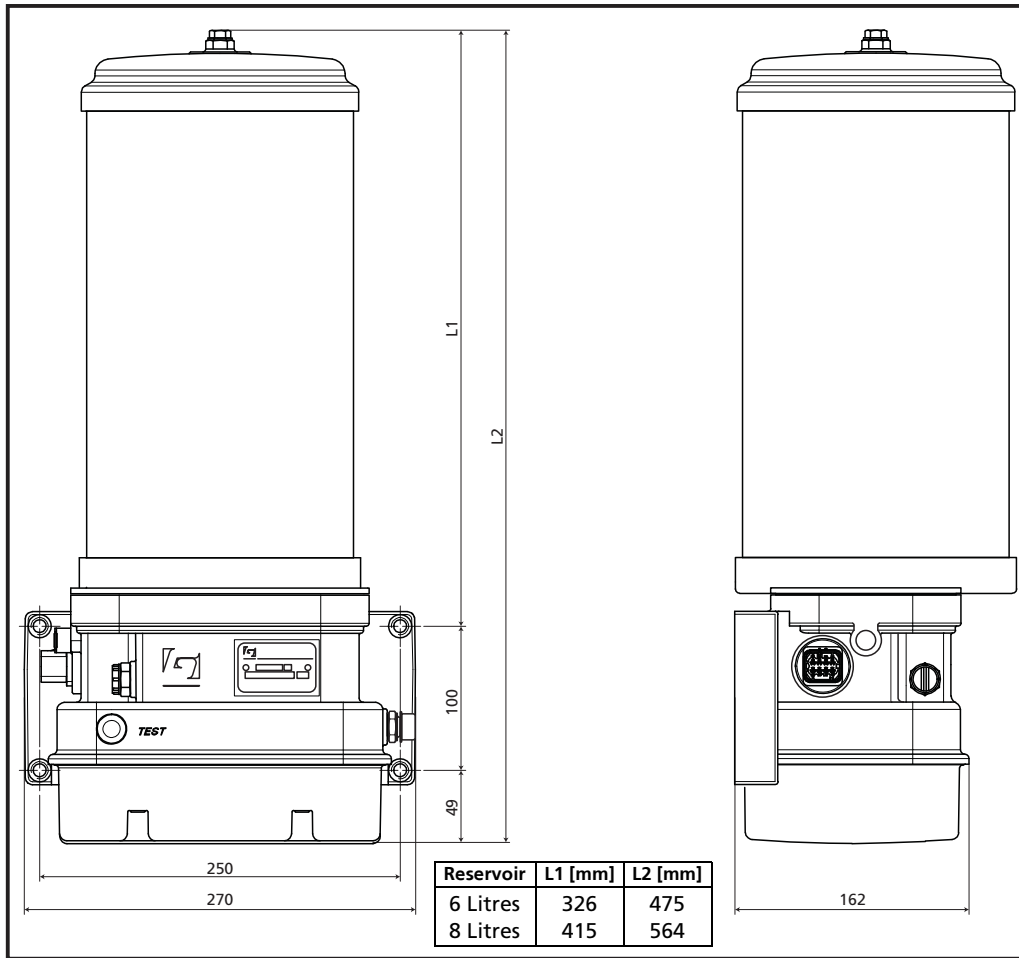

Figure 5.2 Dimensions Twin pump with a 6 or 8 litre reservoir

## 5.2 Signal lamp

Max. allowed power consumption: 3W

### 5.3 Twin display

#### **Regulations / EMC**

Off road ISO 13766-2006

Road transport 2004/104/EC

Industrial equipment 2004/108/EC

#### **Environment**

Ambient operating temperature range: -25...+70 °C

Storage temperature range: -25...+70 °C

Casing humidity/dust: IP54

#### **Electrical**

Supply operating voltage range: 9...32 VDC

Max. operating current: 220 mA

Open drain outputs max current: 250 mA

Open drain max voltage: 32 VDC

Cable length max: 5 meter

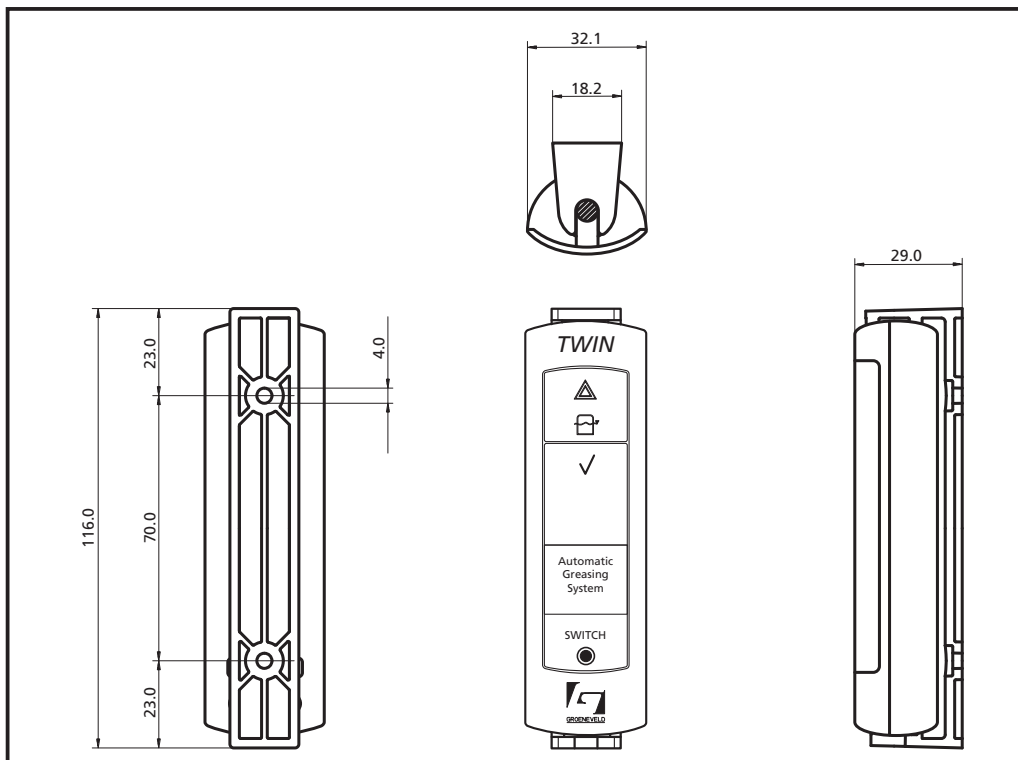

Figure 5.3 Dimensions of the Twin display





[www.groeneveld-group.com](http://www.groeneveld-group.com)

