

## 1.1 OVERVIEW

This book is the second volume of digital signal processing applications based on the ADSP-2100 DSP microprocessor family. It contains a compilation of routines for a variety of common digital signal processing applications. As in the first volume, you may use these routines without modification or you can use them as a starting point for the development of routines tailored to your particular needs.

Besides showing the specific applications, these routines demonstrate a variety of programming techniques for getting the most performance out of the ADSP-2100 family processors. For example, several routines show you how to use address pointers efficiently to address circular buffers. We believe that you will benefit from reading every chapter, even if your present application uses only a single topic.

Some material in this book was originally published in an applications handbook that featured modem routines. The information in that volume was updated and integrated into this book, which supersedes the earlier publication.

## 1.2 ADSP-2100 FAMILY PROCESSORS

This section briefly describes the ADSP-2100 family of processors. For complete information, refer to the *ADSP-2100 Family User's Manual*, (ISBN 0-13-006958-2) available from Prentice Hall and Analog Devices. For the applications in this book, "ADSP-2100" refers to *any* processor in the ADSP-2100 family unless otherwise noted. At the time of publication, the ADSP-2100 Family consisted of the following members:

- ADSP-2100A—DSP microprocessor with off-chip Harvard architecture
- ADSP-2101—DSP microcomputer with on-chip program and data memory
- ADSP-2103—Low-voltage microcomputer, 3.3-volt version of ADSP-2101

# 1 Introduction

- ADSP-2105—Low-cost DSP microcomputer
- ADSP-2111—DSP microcomputer with Host Interface Port
- ADSP-2115—High-performance, Low-cost DSP microcomputer
- ADSP-2161/62/63/64—Custom ROM-programmed DSP microcomputers
- ADSP-2165/66—Custom ROM-programmed DSP microcomputers with larger on-chip memories and powerdown
- ADSP-21msp5x—Mixed-Signal DSP microcomputers with integrated, on-chip analog interface and powerdown
- ADSP-2171—Enhanced ADSP-2100 Family processor offering 33 MIPS performance, host interface port, powerdown, and instruction set extensions for bit manipulation, multiplication, biased rounding, and global interrupt masking

Since Analog Devices strives to provide products that exploit the latest technology, new family members will be added to this list periodically. Please contact your local Analog Devices sales office or distributor for a complete list of available products.

The ADSP-2100A is a programmable single-chip *microprocessor* optimized for digital signal processing and other high-speed numeric processing applications. The ADSP-2100A contains an ALU, a multiplier/accumulator (MAC), a barrel shifter, two data address generators and a program sequencer. It features an off-chip Harvard architecture, where data and program buses are available to external memories and devices.

The ADSP-2101 is a programmable single-chip *microcomputer* based on the ADSP-2100A. Like the ADSP-2100A, the ADSP-2101 contains computational units, as well as a program sequencer and dual address generators; these elements, combined with internal data and address busses, comprise the base architecture of the ADSP-2100 Family microcomputers. Additionally, all family members have the following core features:

- on-chip data memory, program memory, and boot memory
- one or two serial ports
- a programmable timer
- and enhanced interrupt capabilities.

# Introduction 1

To expand the usefulness of the ADSP-2100 Family, the base architecture has been enhanced with a variety of memory configurations, peripheral devices, and features for improved performance. Table 1.1 is a matrix that identifies the functional differences between members of the ADSP-2100 Family.

Model	Instruction Cycle Times	Internal Program Memory	Internal Data Memory	Host Interface Port	Program Memory Boot	Serial Ports	Programmable Timer	On-chip A/D & D/A	External Interrupts	Low Power Modes	Pin Count
ADSP-2100	80	CACHE	—	—	—	—	—	—	4	—	100
ADSP-210	50	2k x 24	1K X 16	—	√	2	√	—	3	1	80/68
ADSP-210	50	2k x 24 RAM/ROM	1K X 16	—	√	2	√	—	3	1	80/68
ADSP-2103(3)	77	2k x 24	1K X 16	—	√	2	√	—	3	1	80/68
ADSP-210	100	1k x 24	0.5K X 16	—	√	1	√	—	3	1	68
ADSP-211	50	2k x 24	1K X 16	√	√	2	√	—	3	1	100
ADSP-211	50	1k x 24	0.5K X 16	—	√	2	√	—	3	1	80/68
ADSP-21msp50	77	2k x 24	1K X 16	√	√	2	√	√	3	2	144
ADSP-21msp50	77	2k x 24	1K X 16	√	√	2	√	√	3	2	100
ADSP-21msp50	77	2k x 24 & 2k x 24 ROI	1K X 16	√	√	2	√	√	3	2	100
ADSP-216	60	8k x 24 ROI	0.5K X 16	—	√	2	√	—	3	1	80/68
ADSP-2162(3)	100	8k x 24 ROI	0.5K X 16	—	√	2	√	—	3	1	80/68
ADSP-216	60	2k x 24 ROI	0.5K X 16	—	√	2	√	—	3	1	80/68
ADSP-2164(3)	100	2k x 24 ROI	0.5K X 16	—	√	2	√	—	3	1	80/68
ADSP-216	60	1K X 24 RAM 12k x 24 ROI	4K X 16	—	√	2	√	—	3	1	80
ADSP-2166(3)	100	2k x 24 ROI	0.5K X 16	—	√	2	√	—	3	1	80
ADSP-217	30	2k x 24 RAM 8k x 24 ROI	2K X 16	√	√	2	√	—	3	1	128

**Table 1.1 ADSP-2100 Family Functional Differences**

# 1 Introduction

This chapter includes overviews of the ADSP-2100 family base architecture and the three family members that exhibit the most distinct features. These overviews include the following ADSP-2100 Family members:

- ADSP-2100 Family Base Architecture—contains the computational units, address generators, and program sequencer
- ADSP-2101—contains the base architecture, plus on-chip memory (program, data, and boot memory), a programmable timer, and enhanced interrupts
- ADSP-2111—contains the features of the ADSP-2101, plus a host interface port (HIP)
- ADSP-21msp50—contains the features of the ADSP-2101, plus a host interface port (HIP) and a voice-band analog front end

Other family members are variations on these DSPs. For example, the ADSP-2105 is based on the ADSP-2101, but it has less on-chip memory and only one serial port; the ADSP-2171 is similar to the ADSP-2111, except it has functional enhancements (low-power operation and expanded instruction set).

Because all the microcomputers of the ADSP-2100 family are code-compatible, the programs in this book can be executed on any DSP in the family, although some modifications for interrupt vectors, peripherals, and control registers may be necessary. All the programs in this book, however, are not designed to use the extra features and functions of some family members.

## 1.2.1 ADSP-2100 Family Base Architecture

This section gives a broad overview of the ADSP-2100 family base architecture (shown in Figure 1.1). Refer to the *ADSP-2100 Family User's Manual* for additional details.

The base architecture contains three full-function and independent computational units: an arithmetic/logic unit, a multiplier/accumulator and a barrel shifter. The computational units process 16-bit data directly and provide for multiprecision computation.

# Introduction 1

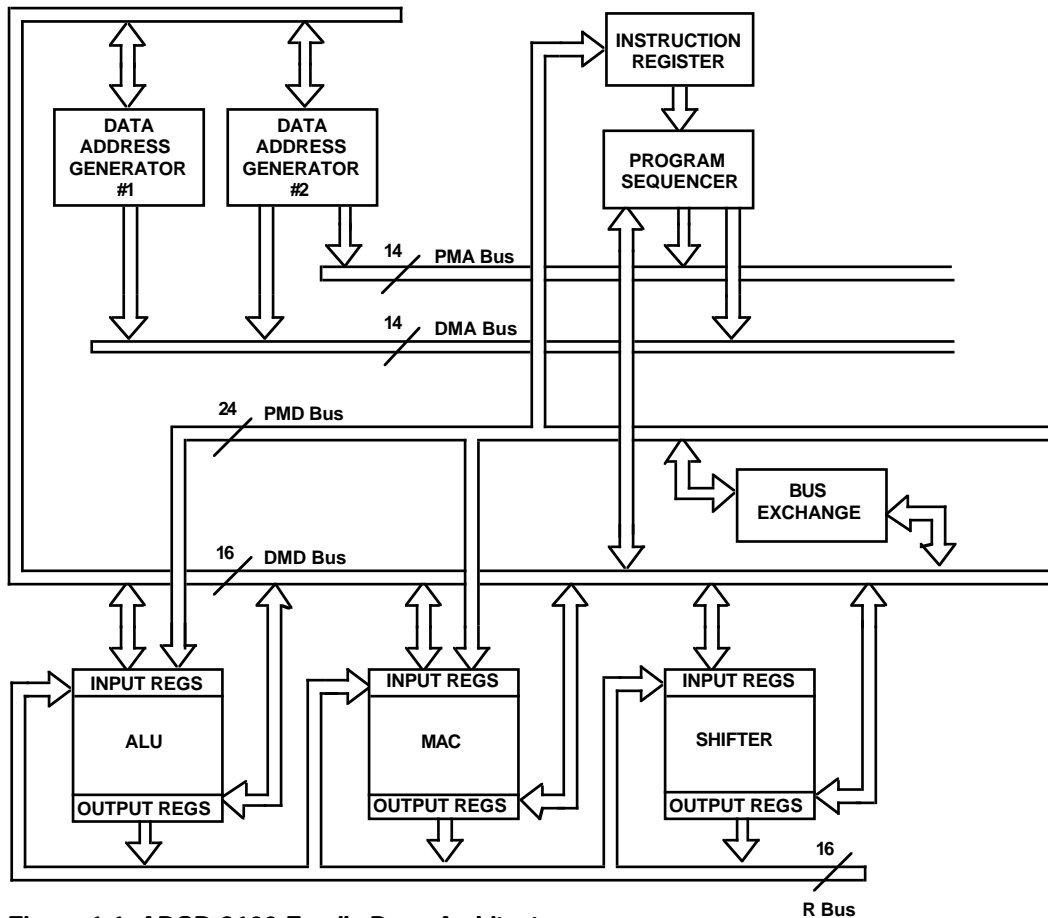

**Figure 1.1 ADSP-2100 Family Base Architecture**

A program sequencer and two dedicated data address generators (used to simultaneously access data in two locations) supply addresses to memory. The sequencer supports single-cycle conditional branching and executes program loops with zero overhead. Dual address generators allow the processor to output simultaneous addresses for dual operand fetches. Together the sequencer and data address generators allow computational operations to execute with maximum efficiency. The ADSP-2100 family uses an enhanced Harvard architecture in which data memory stores data, and program memory stores instructions and data. This feature lets ADSP-2100 family processors fetch two operands on the same instruction cycle.

# 1 Introduction

Five internal buses support the internal components.

- Program Memory Address (PMA) bus
- Program Memory Data (PMD) bus
- Data Memory Address (DMA) bus
- Data Memory Data (DMD) bus
- Result (R) bus (which interconnects the computational units)

The program memory data (PMD) bus serves primarily to transfer instructions from program memory to the instruction register. Instructions are fetched and loaded into the instruction register during one processor cycle; they execute during the following cycle while the next instruction is being fetched. The instruction register introduces a single level of pipelining in the program flow.

The next instruction address is generated by the program sequencer depending on the current instruction and internal processor status. This address is placed on the program memory address (PMA) bus. The program sequencer uses features such as conditional branching, loop counters and zero-overhead looping to minimize program flow overhead. The program memory address (PMA) bus is 14 bits wide, allowing direct access to up to 16K words of instruction code and data.

The data memory address (DMA) bus is 14 bits wide allowing direct access of up to 16K words of data. The data memory data (DMD) bus is 16 bits wide. The data memory data (DMD) bus provides a path for the contents of any register in the processor to be transferred to any other register, or to any data memory location, *in a single cycle*. The data memory address can come from two sources: an absolute value specified in the instruction code (direct addressing) or the output of a data address generator (indirect addressing). Only indirect addressing is supported for data fetches through the program memory bus.

The program memory data (PMD) bus can also be used to transfer data to and from the computational units through direct paths or through the PMD-DMD bus exchange unit. The PMD-DMD bus exchange unit permits data to be passed from one bus to the other. It contains hardware to overcome the 8-bit width discrepancy between the two buses when necessary.

Each computational unit contains a set of dedicated input and output registers. Computational operations generally take their operands from input registers and load the result into an output register. The

computational units are arranged in parallel rather than cascaded. To avoid excessive delays when a series of different operations is performed, the internal result (R) bus allows any of the output registers to be used directly (without delay) as the input to another computation.

There are two independent data address generators (DAGs). As a pair, they allow the simultaneous fetch of data stored in program and in data memory for executing dual-operand instructions in a single cycle. One data address generator (DAG1) can supply addresses to the data memory only; the other (DAG2) can supply addresses to either the data memory or the program memory. Each DAG can handle linear addressing as well as modulo addressing for circular buffers.

With its multiple bus structure, the ADSP-2100 family architecture supports a high degree of operational parallelism. In a single cycle, a family processor can fetch an instruction, compute the next instruction address, perform one or two data transfers, update one or two data address pointers and perform a computation. Every instruction can be executed in a single cycle.

## 1.2.2 ADSP-2101 Architecture

Figure 1.2 shows the architecture of the ADSP-2101 processor. In addition to the base architecture, the ADSP-2101 has two serial ports, a programmable timer, enhance interrupts, and internal program, data and boot memory.

The ADSP-2101 has 1K words of 16-bit data memory on-chip and 2K words of 24-bit program memory on-chip. The processor can fetch an operand from on-chip data memory, an operand from on-chip program memory and the next instruction from on-chip program memory in a single cycle.

This scheme is extended off-chip through a single external memory address bus and data bus that may be used for either program or data memory access and for booting. Consequently, the processor can access external memory once in any cycle.

Boot circuitry provides for loading on-chip program memory automatically after reset. Wait states are generated automatically for interfacing to a single low-cost EPROM. Multiple programs can be selected and loaded from the EPROM with no additional hardware.

# 1 Introduction

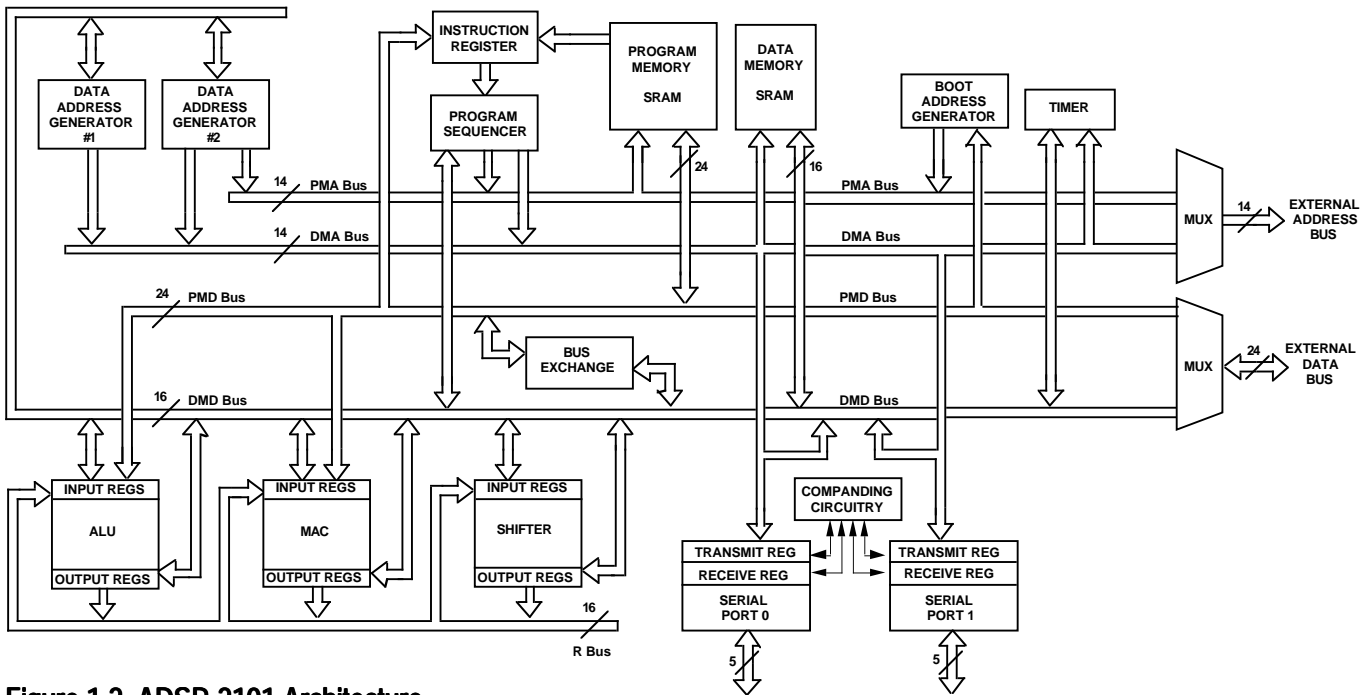

Figure 1.2 ADSP-2101 Architecture

The memory interface supports memory-mapped peripherals with programmable wait-state generation. External devices can gain control of buses with bus request and grant signals (**BR** and **BG**). An optional execution mode allows the ADSP-2101 to continue running from internal memory while the buses are granted to another master as long as an external memory operation is not required.

The ADSP-2101 can respond to six user interrupts. There can be up to three external interrupts, configured as edge- or level-sensitive. Internal interrupts can be generated from the timer and the serial ports. There is also a master **RESET** signal.

The two serial ports (“SPORTs”) provide a synchronous serial interface; they interface easily and directly to a wide variety of popular serial devices. They have hardware companding (data compression and expansion) with both  $\mu$ -law and A-law available. Each port can generate an internal programmable clock or accept an external clock.

The SPORTs are synchronous and use framing signals to control data flow. Each SPORT can generate its serial clock internally or use an external clock. The framing synchronization signals may be generated internally or



by an external device. Word lengths may vary from three to sixteen bits. One SPORT (SPORT0) has a multichannel capability that allows the receiving or transmitting of arbitrary data words from a 24-word or 32-word bitstream. The SPORT1 pins have alternate functions and can be configured as two additional external interrupt pins and Flag Out (FO) and Flag In (FI).

The programmable interval timer provides periodic interrupt generation. An 8-bit prescaler register allows the timer to decrement a 16-bit count register over a range from each cycle to every 256 cycles. An interrupt is generated when this count register reaches zero. The count register is automatically reloaded from a 16-bit period register, and the count resumes immediately.

### 1.2.3 ADSP-2111 Architecture

Figure 1.3 shows the architecture of the ADSP-2111 processor. The ADSP-2111 contains the same architecture of the ADSP-2101—plus a host interface port (HIP). This section only contains a brief overview; for detailed descriptions of the HIP and its operation, refer to the ADSP-2111 data sheet and *ADSP-2100 Family User's Manual*.

The host interface port is a parallel I/O port that lets the DSP act as a memory mapped peripheral (slave DSP) to a host computer or processor. You can think of the host interface port as a collection of dual-ported memory, or mailbox registers, that let the host processor communicate with the DSP's processor core. The host computer addresses the HIP as a section of 8-bit or 16-bit words of memory. To the processor core, the HIP is a group of eight data mapped registers.

The host interface port is completely asynchronous. This means that the host computer can write data into the HIP while the ADSP-2111 is operating at full speed.

The ADSP-2111 supports two types of booting operations. One method boots the DSP from external memory (usually an EPROM) through the boot memory interface. The *ADSP-2100 Family User's Manual* describes the boot memory interface in detail. In the second method, a boot program is loaded from the host computer through the HIP. Chapter 12, *Hardware Interface* includes a sample of code to load a program through the HIP.

# 1 Introduction

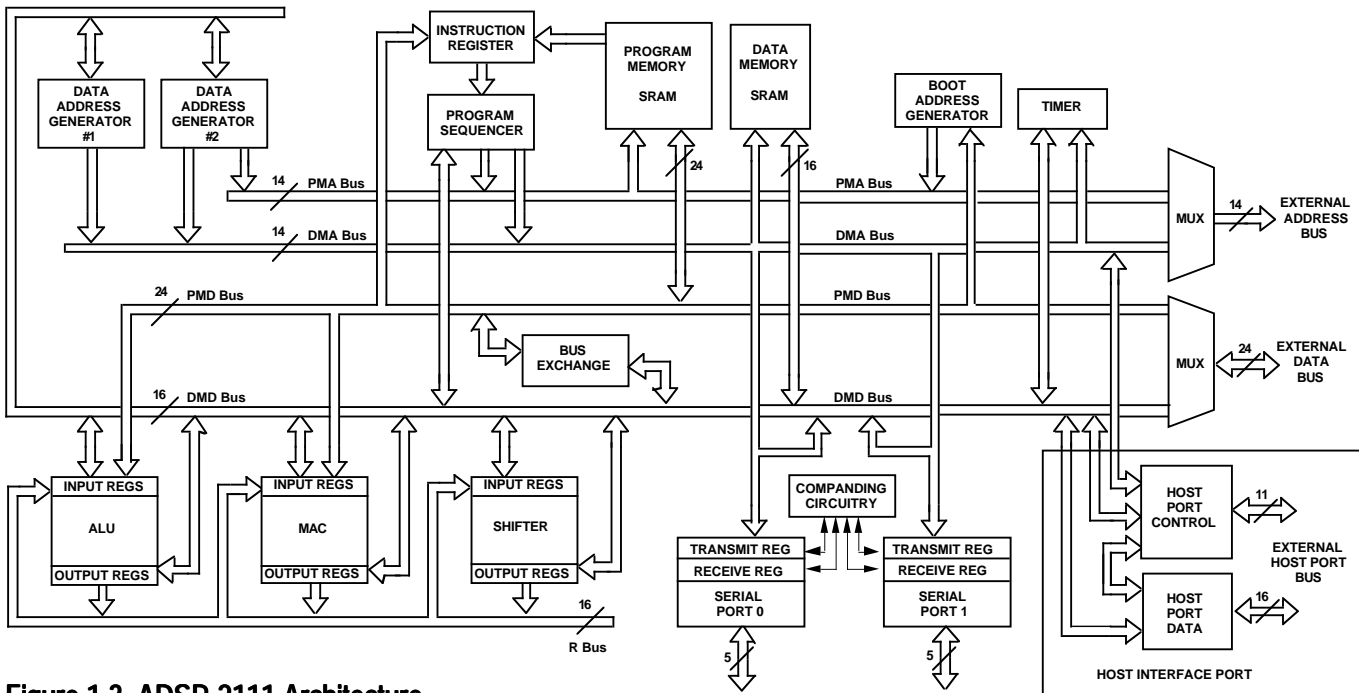

Figure 1.3 ADSP-2111 Architecture

## 1.2.4 ADSP-21msp50 Architecture

Figure 1.4 shows the architecture of the ADSP-21msp50 processor. The ADSP-21msp50 contains the same core architecture of the ADSP-2101—plus a host interface port (described in the previous section) and an analog interface. This section only contains a brief overview; for detailed descriptions of the analog interface and its operation, refer to the ADSP-21msp50 data sheet and *ADSP-2100 Family User's Manual*.

The ADSP-21msp50 has an analog interface that provides the following features:

- linear-coded 16-bit sigma-delta ADC
- linear-coded 16-bit sigma-delta DAC
- on-chip anti-aliasing and anti-imaging filters
- individual interrupts for the ADC and DAC
- 8 kHz sampling frequency
- programmable gain for DAC and ADC
- on-chip voltage reference

# Introduction 1

The analog interface is configured and operated through several memory mapped control and data registers. The ADC and DAC I/O can be transmitted and received through individual memory mapped registers, or the data can be autobuffered directly into the processor's data memory.

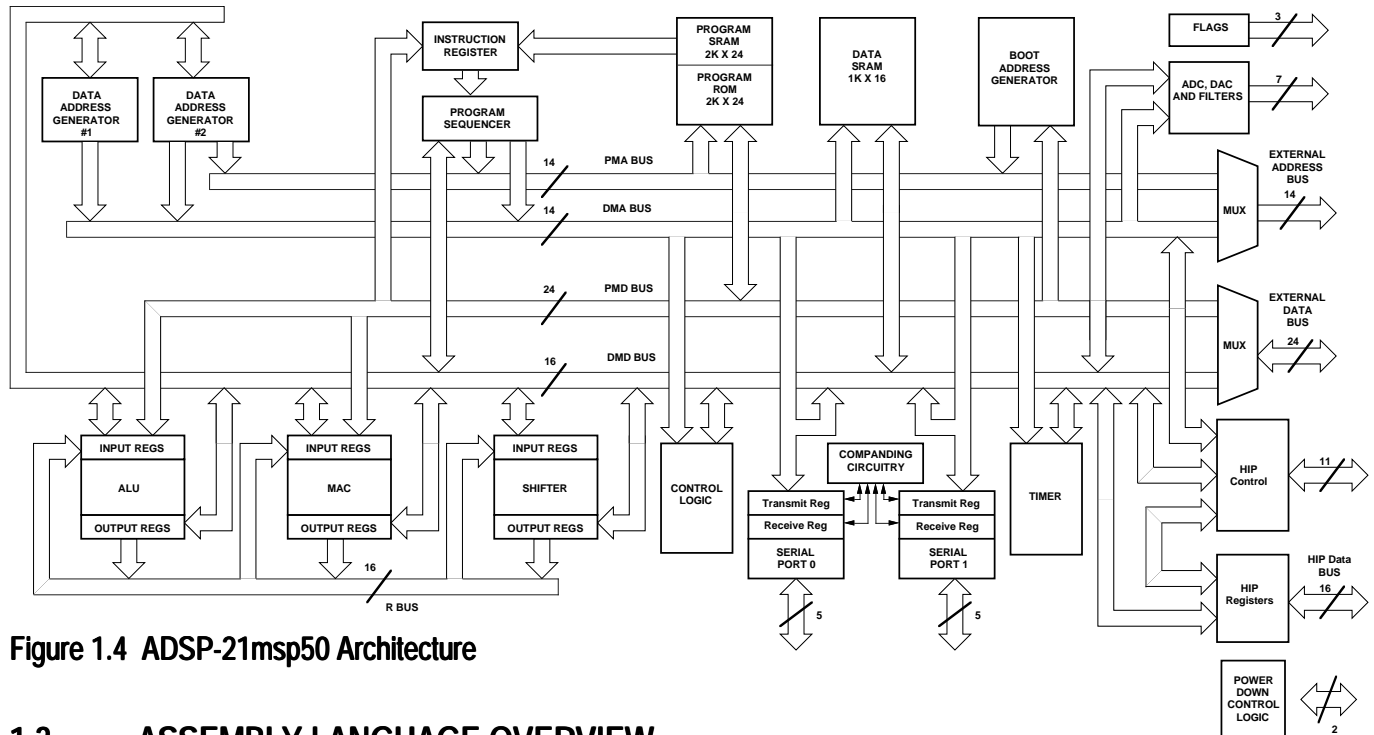

Figure 1.4 ADSP-21msp50 Architecture

## 1.3 ASSEMBLY LANGUAGE OVERVIEW

The ADSP-2100 family's assembly language uses an algebraic syntax for ease of coding and readability. The sources and destinations of computations and data movements are written explicitly in each assembly statement, eliminating cryptic assembler mnemonics. Each assembly statement, however, corresponds to a single 24-bit instruction, executable in one cycle. Register mnemonics, listed below, are concise and easy to remember.

# 1 Introduction

<i>Mnemonic</i>	<i>Definition</i>
AX0, AX1, AY0, AY1	ALU inputs
AR	ALU result
AF	ALU feedback
MX0, MX1, MY0, MY1	Multiplier inputs
MR0, MR1, MR2	Multiplier result (3 parts)
MF	Multiplier feedback
SI	Shifter input
SE	Shifter exponent
SR0, SR1	Shifter result (2 parts)
SB	Shifter block (for block floating-point format)
PX	PMD-DMD bus exchange
I0 - I7	DAG index registers
M0 - M7	DAG modify registers
L0 - L7	DAG length registers (for circular buffers)
PC	Program counter
CNTR	Counter for loops
ASTAT	Arithmetic status
MSTAT	Mode status
SSTAT	Stack status
IMASK	Interrupt mask
ICNTL	Interrupt control modes
RX0, RX1	Receive data registers (not on ADSP-2100A)
TX0, TX1	Transmit data registers (not on ADSP-2100A)

Instruction sets for other family members are upward-compatible supersets of the ADSP-2100A instruction set; thus, programs written for the ADSP-2100A can be executed on any family member with minimal changes.

Here are some examples of the ADSP-2100 family assembly language. The statement

```
MR = MR + MX1*MY1;
```

performs a multiply/accumulate operation. It multiplies the input values in registers MX1 and MY1, adds that product to the current value of the MR register (the result of the previous multiplication) and then writes the new result to MR.

The statement

```
DM(buffer1) = AX0;
```

writes the value of register AX0 to data memory at the location that is the value of the variable *buffer1*.

## 1.4 DEVELOPMENT SYSTEM

The ADSP-2100 family is supported with a complete set of software and hardware development tools. The ADSP-2100 Family Development System consists of Development Software, to aid in software design, and in-circuit emulators, like the EZ-ICE®, to facilitate the debug cycle. Development tools, like the EZ-LAB® Development Board, are also available to provide a hardware platform for experiments and to evaluate processor functions. Additional development tool capabilities continue to be added as new members of the processor family are introduced.

The Development Software includes:

- System Builder

This module allows the designer to specify the amount of RAM and ROM available, the allocation of program and data memory and any memory-mapped I/O ports for the target hardware environment. It uses high-level constructs to simplify this task. This specification is used by the linker, simulators, and emulators.

- Assembler

This module assembles a user's source code and data modules. It supports the high-level syntax of the instruction set. To support modular code development, the Assembler provides flexible macro processing and "include" files. It provides a full range of diagnostics.

- Linker

The Linker links separately assembled modules. It maps the linked code and data output to the target system hardware, as specified by the System Builder output.

# 1 Introduction

- Simulator

This module performs an instruction-level simulated execution of ADSP-2100 family assembly code. The interactive user interface supports full symbolic assembly and disassembly of simulated instructions. The Simulator fully simulates the hardware configuration described by the System Builder module. It flags illegal operations and provides several displays of the internal operations of the processor.

- PROM Splitter

This module reads the Linker output and generates PROM-programmer-compatible files.

- C Compiler

The C Compiler reads ANSI C source and outputs source code ready to be assembled. It also supports inline assembler code.

In-circuit emulators provide stand-alone, real-time, in-circuit emulation. The emulators provide program execution with little or no degradation in processor performance. The emulators duplicate the simulators' interactive and symbolic user interface.

Complete information on development tools is available from your local authorized distributor or Analog Devices sales office.

## 1.5 CONVENTIONS OF NOTATION

The following conventions are used throughout this book:

- Many listings begin with a comment block that summarizes the calling parameters, the return values, the registers that are altered, and the computation time of the routine (in terms of the routine's parameters, in some cases).
- In listings, all keywords are uppercase; user-defined names (such as labels, variables, and data buffers) are lowercase. In text, keywords are uppercase and user-defined names are lowercase italics. Note that this convention is for readability only.

- In comments, register values are indicated by “=” if the register contains the value or by “—>” if the register points to the value in memory.
- All numbers are decimal unless otherwise specified. In listings, constant values are specified in binary, octal, decimal, or hexadecimal by the prefixes B#, O#, D#, and H#, respectively.

## 1.6 PROGRAMS ON DISK

This book includes an IBM PC 3½ inch high-density diskette containing the routines that appear in this book. As with the printed routines, we cannot guarantee suitability for your application.

## 1.7 FOR FURTHER SUPPORT

If you need applications engineering assistance with the applications in this book, please contact:

Applications Engineering from your local Analog Devices distributor

Analog Devices, Inc.  
DSP Applications Engineering  
One Technology Way  
Norwood, MA 02062-9106  
Tel: (617) 461-3672  
Fax: (617) 461-3010  
e\_mail: [dsp\\_applications@analog.com](mailto:dsp_applications@analog.com)

Or log into the DSP Bulletin Board System:

Tel: (617) 461-4258  
300, 1200, 2400, 9600, 14400 baud, no parity, 8 bits data, 1 stop bit