

BER MEASUREMENT IN THE NOISY CHANNEL

PREPARATION	2
overview	2
the basic system.....	3
a more detailed description	3
theoretical predictions	5
EXPERIMENT	6
the ERROR COUNTING UTILITIES module	6
modelling the transmission system	7
1.0: the transmitter	7
2.0: the channel model	8
3.0: the receiver.....	8
4.0: the BER measurement instrumentation	9
5.0 error counting with noise.....	11
preparation	11
adding noise - principle.....	12
adding noise - practice	12
6.0 DC threshold adjustment.....	13
method #1.....	14
method #2.....	14
measuring the BER.....	14
role of the filter	15
conclusion	15
TUTORIAL QUESTIONS	15
APPENDIX.....	17
the ERROR COUNTING UTILITIES module	17
X-OR gate	17
gate timing pulse	17

BER MEASUREMENT IN THE NOISY CHANNEL

ACHIEVEMENTS: *ability to set up a digital communications system over a noisy, bandlimited channel, with provision for line-coding, and instrumentation for BER measurements. This system will be used for many future experiments.*

PREREQUISITES: *completion of the first five experiments in Volume D1 would be an advantage, especially those entitled **The noisy channel model**, and **Detection with the DECISION MAKER**.*

EXTRA MODULES: *LINE-CODE ENCODER, LINE-CODE DECODER, DECISION MAKER, NOISE GENERATOR, ERROR COUNTING UTILITIES, WIDEBAND TRUE RMS METER, an extra SEQUENCE GENERATOR, BASEBAND CHANNEL FILTERS.*

PREPARATION

overview

This experiment serves as an introduction to bit error rate (BER) measurement. It models a digital communication system transmitting binary data over a noisy, bandlimited channel. A complete instrumentation setup is included, that allows measurement of BER as a function of signal-to-noise ratio (SNR).

Many variations of this system are possible, and the measurement of the performance of each of these can form the subject of separate experiments.

In this first experiment the system is configured in its most elementary form.

Other experiments can add different forms of message coding, line coding, different channel characteristics, bit clock regeneration, and so forth.

the basic system

A simplified block diagram of the basic system is shown in Figure 1 below.

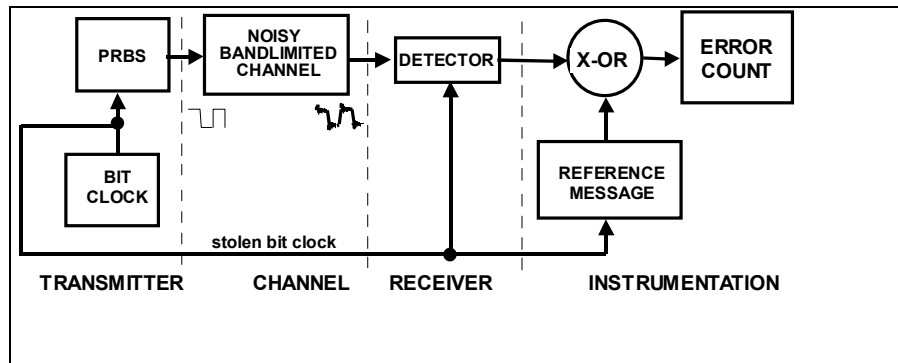

Figure 1: block diagram of system

The system can be divided into four sections:

the transmitter

At the *transmitter* is the originating message sequence, from a pseudo random binary sequence (PRBS) generator, driven by a system bit clock.

the channel

The *channel* has provision for changing its bandlimiting characteristic, and the addition of noise or other sources of interference.

the receiver

The *receiver* (detector) regenerates the transmitted (message) sequence. It uses a stolen bit clock.

the BER instrumentation

The *instrumentation* consists of the following elements:

1. a sequence generator identical to that used at the transmitter. It is clocked by the system bit clock (stolen, in this case). This sequence becomes the reference against which to compare the received sequence.
2. a means of aligning the instrumentation sequence generator with the received sequence. A *sliding window correlator* is used. This was introduced in the experiment entitled *Detection with the DECISION MAKER* in Volume D1.
3. a means of measuring the errors, after alignment. The error signal comes from an X-OR gate. There is one pulse per error. The counter counts these pulses, over a period set by a gate, which may be left open for a known number of bit clock periods.

a more detailed description

Having examined the overall operation of the basic system, and gained an idea of the purpose of each element, we proceed now to show more of the specifics you will need when modelling with TIMS.

So Figure 1 has been expanded into Figure 2 below.

The detector is the DECISION MAKER module, introduced in the experiment entitled *Detection with the DECISION MAKER*.

The LINE-CODE ENCODER and LINE-CODE DECODER modules were introduced in the experiment entitled *Line coding* in Volume D1.

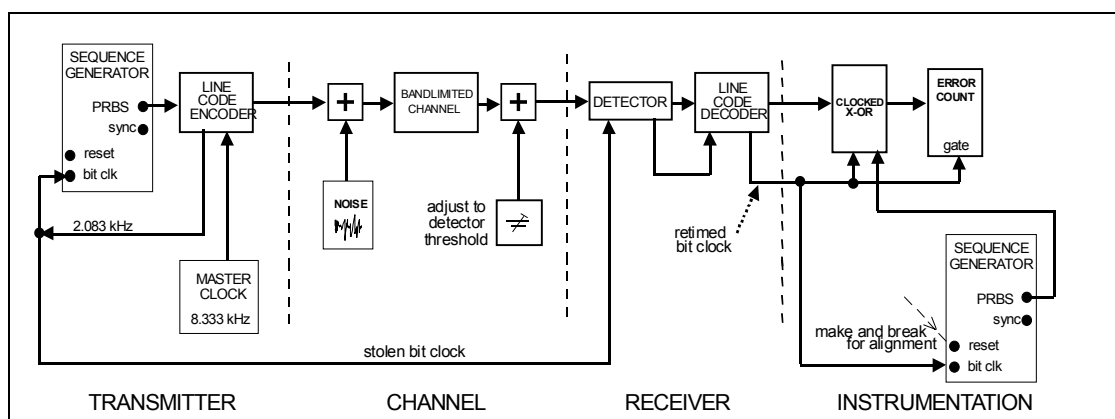

Figure 2: block diagram of system in more detail

The extra detail in Figure 2 includes:

1. provision for transforming the data before transmission, using any one of a number of line codes. In this experiment we use the NRZ-L code which provides level shift and amplitude scaling, to suit the analog channel.
2. bit clock generation. Because the line coder requires quarter-bit-period timing information, it is driven by a *master clock* at four-times the bit-clock rate. The timing information is obtained by dividing the master clock by four (within the LINE-CODE ENCODER). This divided-by-four version of the *master clock* becomes the *system bit clock*.
3. provision for adding noise to the channel via the adder on the *input* side of the bandlimiting channel.
4. inclusion of an ADDER on the output side of the channel. This restores the polarity change introduced by the input ADDER (for line codes which are polarity sensitive). It also provides an opportunity to fine-trim the DC level to match the threshold of the DECISION MAKER.
5. a decoder for the line code.
6. instrumentation for SNR adjustment (not shown) and BER measurement.

theoretical predictions

Bit error probability (P_B) is a function of E_b/N_o . For matched filter reception of bi-polar baseband signalling it has been shown that:

$$P_B = Q\left(\sqrt{\frac{2E_b}{N_o}}\right) \quad \dots\dots 1$$

The symbols are defined in the Chapter entitled *BER instrumentation macro module* in this Volume

You will measure not P_B , but BER; and not E_b/N_o , but SNR. Figure 3 shows theoretical predictions, based on eqn(1) above.

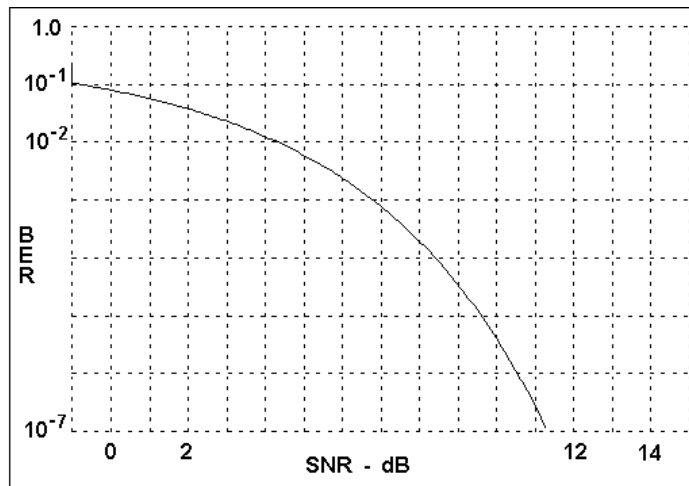

Figure 3 theoretical expectations - BER versus SNR (for bi-polar signalling)

EXPERIMENT

Familiarity with the setting up of a transmitter, receiver, and noisy channel, using a stolen clock for bit clock synchronization, and the sliding window correlator for sequence alignment, is assumed.

The system under examination, the principle of which is illustrated in block diagram form in Figure 1, is shown modelled by the patching diagram of Figure 4 on the next page. Within that diagram is included the macro CHANNEL MODEL module, and the BER INSTRUMENTATION macro module.

The macro CHANNEL MODEL module was introduced in the experiment entitled *The noisy channel model* in Volume D1, which you should already have completed.

As a reminder, details of the macro CHANNEL MODEL module are reproduced in Figure 4 below.

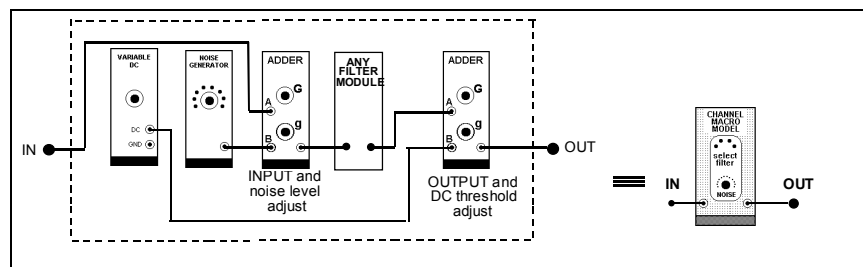

Figure 4: details of the macro CHANNEL MODEL module

Remember that, during testing, and afterwards, the oscilloscope triggering comes from:

- the SYNC output from the transmitter SEQUENCE GENERATOR for snapshots
- the bit clock for eye patterns.

the ERROR COUNTING UTILITIES module

This is the first time the pulse counting capabilities of the ERROR COUNTING UTILITIES module have been used. A complete description of the characteristics and behaviour of the module can be obtained from the *TIMS Advanced Modules User Manual*.

A condensed description of its function is given in the Chapter entitled *Digital utility sub-systems* in this Volume, under the two headings *Timed Pulse* (for the counting function) and *Exclusive-OR*.

modelling the transmission system

The system to be modelled is shown in Figure 5. It will be patched up systematically, section by section, according to the scheme detailed below. It has not been cluttered by showing oscilloscope connections. You should set up the SCOPE SELECTOR for maximum usage of the facility for toggling between the A and B options for each channel.

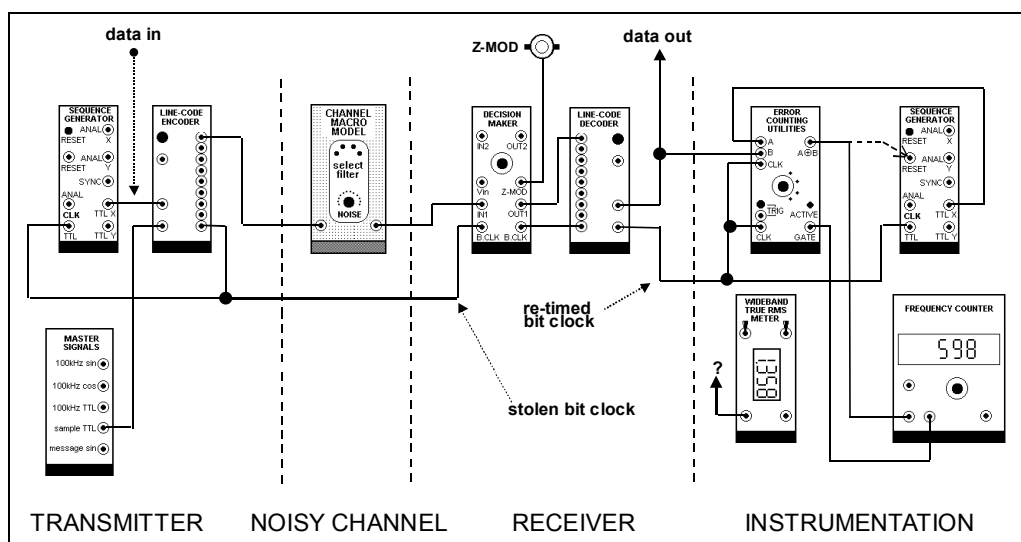

Figure 5: the TIMS model of Figure 2

1.0: the transmitter

T1.1 patch the transmitter according to Figure 5, from a SEQUENCE GENERATOR (set to a short sequence - both toggles of SW2, on circuit board, UP), a LINE-CODE ENCODER (using NRZ-L), and the MASTER SIGNALS module. Note that the LINE-CODE ENCODER accepts the **master clock**, which is the 8.333 kHz TTL 'sample clock' from the MASTER SIGNALS module, and divides it by four to produce the 2.083 kHz **system bit clock** for the SEQUENCE GENERATOR.

T1.2 press the reset on the LINE-CODE ENCODER. Check on CH1-A that a short TTL sequence has been generated by the SEQUENCE GENERATOR.

T1.3 simultaneously with the previous observation on CH1-A, check the NRZ-L output of the LINE-CODE ENCODER on CH2-A. Relative to the TTL on CH1-A it will be delayed half a bit period. This is the signal being transmitted to the channel. Confirm the code format.

2.0: the channel model

The macro CHANNEL MODEL module is shown modelled in Figure 4.

- T2.1 patch up the channel according to Figure 4 and insert it into the position shown in Figure 5.*
- T2.2 set the front panel attenuator of the NOISE GENERATOR to maximum output; but reduce the channel noise to zero by rotating the INPUT ADDER gain control 'g' fully anti-clockwise.*
- T2.3 adjust the amplitude of the signal **into** the BASEBAND CHANNEL FILTERS module to near the TIMS ANALOG REFERENCE LEVEL (say, 2 volt peak-to-peak) with the INPUT ADDER gain control 'G'. This level will need resetting when noise is added.*
- T2.4 select channel #3 of the BASEBAND CHANNEL FILTERS module.*
- T2.5 set the gain of the DC threshold adjustment path through the OUTPUT ADDER to zero.*
- T2.6 adjust the amplitude of the signal **out of** the CHANNEL MODEL to, say, 2 volt peak-to-peak with the OUTPUT ADDER gain control 'G'. The gain through the channel is now unity.*
- T2.7 confirm that the signal at the OUTPUT ADDER, although of different shape, and further delayed, is clearly related to the input sequence.*

When tracing the sequence through the system, notice that there is a polarity inversion introduced by the INPUT ADDER of the channel, and a second inversion introduced by the OUTPUT ADDER.

3.0: the receiver

The receiver consists of the DECISION MAKER and LINE-CODE DECODER modules.

T3.1 before plugging in the DECISION MAKER:

- a) switch the on-board switch SW2 to 'IN' (DECISION POINT can now be adjusted with the front panel control).*
- b) select the expected line code with the on-board rotary switch SW1 (upper rear of board). For this experiment it is NRZ-L.*

T3.2 patch up the DECISION MAKER, including the Z-MOD output to the oscilloscope. It is assumed that the Z-MOD adjustments have been made on the circuit board to suit your oscilloscope ¹.

T3.3 trigger the oscilloscope from the bit clock, and obtain an eye pattern at the channel output. Adjust the sampling instant, with the DECISION MAKER front panel control, to the centre of the eye. Remember that some fine adjustment of the intensity control of the oscilloscope will probably be necessary to easily identify the bright spot at the sampling instant.

T3.4 trigger the oscilloscope from the SYNC output of the transmitter SEQUENCE GENERATOR. Check that the reconstructed 'analog' output from the DECISION MAKER is a delayed version of, but otherwise the same shape as, that at the channel input.

T3.5 refer to the DECISION MAKER in the **TIMS User Manual** for threshold level information. This varies according to the code in use. For the NRZ-L code the threshold is approximately 25 mV. Thus the input signal amplitude must either swamp any possible DC threshold, or, if small, must be adjusted to straddle it. There is provision in the model (the OUTPUT ADDER) for this; it will be checked in the next Section. For now confirm that the output waveform is centred approximately about zero volts.

T3.6 patch up the LINE-CODE DECODER, selecting the NRZ-L output.

T3.7 press the reset on the LINE-CODE DECODER. Check that the TTL output sequence is identical, except for a delay, with that at the transmitter SEQUENCE GENERATOR output.

Do not proceed unless these two TTL signals are identical !

4.0: the BER measurement instrumentation

The transmission system is now fully set up. You will now proceed to verify its overall operation.

The BER measurement instrumentation system is used to generate an *identical* sequence to that transmitted, and *aligned* with that from the receiver detector. These two sequences will be compared, bit by bit, and any disagreements *counted*. The count is made over a pre-determined number of bit clock periods, and so the bit error rate (BER) may be calculated.

You will record the BER for various levels of noise, and compare with theoretical expectations.

¹ refer to the experiment entitled *Detection with the DECISION MAKER*. in Volume D1

T4.1 patch up according to Figure 5. Note the instrumentation (receiver) SEQUENCE GENERATOR uses the LINE-CODE DECODER strobe as its bit clock. Trigger the oscilloscope for a snapshot. Check that there is a short sequence coming from the instrumentation SEQUENCE GENERATOR output.

T4.2 see the Appendix to this experiment for a short description of the ERROR COUNTING UTILITIES module, including on-board jumper and switch settings. Plug it in. Check that the line from the X-OR output to the instrumentation SEQUENCE GENERATOR RESET is **open**.

T4.3 observe the two inputs to the X-OR gate simultaneously. It is unlikely that they are aligned, but they should be synchronized.

Your good work is about to be rewarded with the sight of the two sequences snapping into alignment.

T4.4 momentarily close the line from the X-OR output to the instrumentation SEQUENCE GENERATOR RESET. Confirm that the two sequences, already synchronized, are now aligned.

If you want to see the sliding window correlator at work again, press the reset on the instrumentation SEQUENCE GENERATOR, and alignment will be lost. Re-align by repeating the last Task.

T4.5 set the FREQUENCY COUNTER to its COUNT mode, and patch it into the system, complete with the gate signal from the ERROR COUNTING UTILITIES module.

T4.6 switch the gate of the ERROR COUNTING UTILITIES, with the PULSE COUNT switch, to be active for 10^5 bit clock periods. Make a mental calculation to estimate how long that will be !

T4.7 to make an error count:

a) reset the FREQUENCY COUNTER.

b) start the error count by pressing the TRIG button of the ERROR COUNTING UTILITIES module.

The 'active' LED on the ERROR COUNTING UTILITIES module will light, and remain alight until 90% of the count is completed, when it will blink before finally extinguishing, indicating the count has concluded.

With no noise there should be no errors. But

warning: every time a count is initiated *one count* will be recorded immediately. This is a ‘confidence count’, to reassure you the system is active, especially for those cases when the actual errors are minimal. It does *not* represent an error, and *should always be subtracted from the final count*.

Despite the above single confidence-count you may wish to make a further check of the error counting facility, before using noise.

T4.8 *if the ERROR COUNTING UTILITIES GATE is still open press the instrumentation SEQUENCE GENERATOR reset button (else press the TRIG to open the GATE). The sequences should now be out of alignment.*

The counter will start counting (and continue counting) errors until the GATE shuts. It will record a count of between 2 and 10^n (with the PULSE COUNT switch set to make 10^n counts). You will record a different count each time this is repeated. Why would this be ?

well done !

You have just completed a major setting-up procedure. If it was achieved without any problems you are to be congratulated ! Although TIMS itself will behave reliably, it is easy to make patching errors, and their discovery and rectification is all part of the learning process.

You are now almost ready to sit back and let TIMS do the measurements for you.

5.0 error counting with noise

preparation

T5.1 *increase the message sequence length of both SEQUENCE GENERATOR modules (both toggles of SW2 DOWN). See Tutorial Question Q2.*

T5.2 *re-establish sequence alignment by pressing all the reset buttons, in order input to output, then momentarily connect the X-OR output to the instrumentation SEQUENCE GENERATOR RESET input.*

adding noise - principle

It is now time to add the noise to the signal. Noise must be introduced *before* bandlimiting, since the channel bandlimiting filters are required to bandlimit the noise as well.

The noise from the NOISE GENERATOR is wideband. Its peak amplitude must not overload an analog module, so its output has been restricted to 4 volt peak-to-peak (the TMS ANALOG REFERENCE LEVEL). As soon as it is bandlimited, this amplitude is reduced. Amplification cannot be used to bring it up to a convenient level until *after* bandlimiting. But by this time the signal has been added, so that is not possible.

So the only way to obtain a small signal-to-noise ratio (relatively high noise) is to *reduce* the signal level. This is done with the INPUT ADDER.

To set the noise level:

- a) remove the signal from the channel input
- b) add as much noise as is available, to implement the worst SNR possible, by maximising the gain through the INPUT ADDER, and setting the attenuator of the NOISE GENERATOR for maximum noise output. The SNR can later be increased - less noise - with this attenuator.
- c) measure the noise level into the DECISION MAKER with the WIDEBAND TRUE RMS METER. Then remove the noise, replace the signal, and adjust it to the same level.
- d) replace the noise. The SNR is 0 dB.

The system is now set up for the worst conditions under which measurements are to be made. From now on the SNR will be improved, in *calibrated* steps of the NOISE GENERATOR attenuator, and BER measurements recorded.

The above steps will now be implemented.

adding noise - practice

*T5.3 patch both the oscilloscope and the WIDEBAND TRUE RMS METER to observe the signal at the **output** of the channel.*

T5.4 reduce the signal amplitude to zero with the 'G' gain control of the INPUT ADDER.

*T5.5 set the attenuator of the NOISE GENERATOR for maximum output. Increase the noise level **into** the channel, with the INPUT ADDER, to maximum. **Record the reading of the rms meter (N volt rms amplitude).***

T5.6 remove the noise by unplugging the patch cord from the INPUT ADDER.

*T5.7 introduce some signal with the 'G' control of the channel INPUT ADDER, until the rms meter is reading the same as the previous noise reading. **Record this reading (S volt rms amplitude).***

T5.8 replace the noise. Do not disturb the INPUT ADDER gain settings from now on !

T5.9 check the signal level at the channel output. Use the 'G' gain control of the OUTPUT ADDER to raise the input level to the DECISION MAKER to the TMS ANALOG REFERENCE LEVEL (4 V peak-to-peak is allowable, although there may be insufficient gain in the ADDER).

The SNR is now set up to a reference value $10\log_{10}\left[\frac{S^2}{N^2}\right]dB$

and this will be 0 dB. However you may have your own reasons for selecting some other ratio, but it needs to result in many errors. From now on you can only *reduce* the noise, using the calibrated attenuator of the NOISE GENERATOR. This will *increase* the SNR, which will in turn *reduce* the error rate.

warning: if alignment is ever lost the noise must be removed before attempting re-alignment !

T5.10 set the SNR to, say, 10 dB, and set the decision instant with the aid of an eye pattern.

6.0 DC threshold adjustment

The effect of any DC threshold of the DECISION MAKER must be offset with DC introduced by the OUTPUT ADDER.

Two methods are suggested.

1. after setting up as above, add a small DC to the signal from the channel. If the error count can be reduced then adjust for the smallest count.
2. set the DC output from the channel to +25 mV. This is the threshold level of the DECISION MAKER in NRZ-L mode. Recall the measurement made in this regard in the experiment entitled *Detection with the DECISION MAKER* in Volume D1.

See Tutorial Question Q3.

Now implement one or the other method of threshold adjustment.

method #1

T6.1 set the PULSE COUNT on the DECISION MAKER to 10^5 and press the TRIG button. Adjust the noise level with the attenuator so that errors are accumulating at about 10 per second (watch the second last digit).

T6.2 rotate the VARIABLE DC level about 45° anti-clockwise. Advance the 'g' control of the OUTPUT ADDER about 20° . The error rate should increase.

T6.3 slowly reduce the DC offset voltage magnitude (rotate the VARIABLE DC control clockwise towards zero). The error rate should slowly reduce, then increase. Return to the lowest rate and stay there. This is an important adjustment. It takes some practice. At all times set the error rate (with the noise source attenuator) so it is about 10 errors per second. Concentrate on the second last, and then the last digit, as the minimum is approached.

method #2

T6.4 remove both inputs from the INPUT ADDER. Using both the VARIABLE DC control and the OUTPUT ADDER 'g' control, set the DC level at the input to the DECISION MAKER +25 mV (use the WIDEBAND TRUE RMS METER). Replace the inputs to the INPUT ADDER.

measuring the BER

Everything is now set up for some serious measurements. It is assumed that:

- both SEQUENCE GENERATORS are set for long sequences (both toggles of the on-board switch SW2 are DOWN).
- line code NRZ-L has been patched (for *this* experiment) on the LINE-CODE ENCODER and LINE-CODE DECODER.
- line code NRZ-L has been selected with SW1 on the DECISION MAKER board.
- all reset buttons have been pushed (in turn from input to output).
- levels throughout the system have been set correctly (typically with SNR = 0 dB with max noise from the NOISE GENERATOR).
- DC threshold at the DECISION MAKER has been accounted for.

- signal into the DECISION MAKER is ideally at the TMS ANALOG REFERENCE LEVEL (but probably considerably lower with the model of Figure 4).
- the DECISION POINT of the DECISION MAKER has been set up, using an eye pattern (with 'moderate' noise present - say an SNR of 10 dB).
- the SEQUENCE GENERATOR at the receiver has been aligned with the incoming sequence (carried out with no noise present - a high SNR).
- conditions for a known (reference) SNR are recorded.
- channel bandwidth is recorded (eg, which filter of the BASEBAND CHANNEL FILTERS module is in use).

T6.5 measure BER according to the procedure in Task T4.7. Record the measurement, and the conditions under which it was made. Compare results with counts over short and long periods.

T6.6 decrease the noise level by one increment of the NOISE GENERATOR front panel attenuator. Go to the previous Task. Loop as many times as appropriate.

T6.7 plot BER versus SNR. Relate your results to expectations.

role of the filter

The characteristics of the filter will influence the result. The theoretical results assume an 'ideal' filter. We do not have that.

conclusion

Future experiments will use this system configuration to measure BER under different conditions - for example, with the addition of error control coding, bit clock regeneration, and so on.

It is important, then, that you familiarize yourself with the setting up procedures of the basic system which was the subject of this experiment.

TUTORIAL QUESTIONS

Q1 once sequence alignment is attained, the sliding window correlator is disabled. Explain why alignment is not lost even if the noise level is raised until the BER increases to unacceptably high levels.

Q2 why were you advised to use a long sequence when counting errors ?

Q3 *explain the principle of what you were doing when adjusting the DC at the input to the DECISION MAKER.*

APPENDIX

ERROR COUNTING UTILITIES module

A full description of this module is available in the *TIMS Advanced Module User Manual*. This should be essential reading before the module is used.

Before use it is necessary to check the settings of the on-board switches SW1 and SW2, and the jumper J1.

Briefly, the module consists of two sub-systems:

X-OR gate

This has two modes:

1. *pulse mode*: with a clock signal connected. Acts as a gated sub-system. Somewhere near the middle of each clock pulse it makes an X-OR decision regarding the two TTL inputs. Its output is a TTL HI if they are different, otherwise a LO. In the present application it compares each bit of the regenerated received signal with a reference generator. Differences - which represent errors - are counted by the FREQUENCY COUNTER in COUNT mode.
2. *normal mode*: with no clock input

gate timing pulse

This clocked sub-system, on receipt of a trigger pulse - manual or electronic - outputs a pulse of length (number of clock periods) determined by the front panel switch PULSE COUNT, the toggles of the on-board switch SW2, and jumper J1.

In this experiment the trigger pulse is initiated by the front panel TRIG push button.

The GATE output pulse (a LO, selected by toggle 2 of the on-board switch SW1) is used to activate the FREQUENCY COUNTER, in COUNT mode.

on-board settings for this experiment

<i>switch/jumper</i>	<i>toggle</i>	<i>position</i>	<i>comments</i>
J1		NORM	
SW1	1 - TRIG	HI - to left	suits press button
SW1	2 - GATE	LO - to right	counter activated on LO
SW2	1	ON - to right	PULSE COUNT switch settings times unity
SW2	2	ON - to right	

