





**BW Clutch or Brake  
Sheave, Pilot and Coupling Mount**



In accordance with Nexen’s established policy of constant product improvement, the specifications contained in this manual are subject to change without notice. Technical data listed in this manual are based on the latest information available at the time of printing and are also subject to change without notice.

Technical Support: 800-843-7445  
(651) 484-5900

www.nexengroup.com

	<p style="text-align: center;"> <b>DANGER</b></p> <p>Read this manual carefully before installation and operation. Follow Nexen’s instructions and integrate this unit into your system with care. This unit should be installed, operated and maintained by qualified personnel <b>ONLY</b>. Improper installation can damage your system, cause injury or death. Comply with all applicable codes.</p>	
---	---	---

This document is the original, non-translated, version.

Conformity Declaration: In accordance with Appendix II B of CE Machinery Directive (2006/42/EC):

A Declaration of Incorporation of Partly Completed Machinery evaluation for the applicable EU directives was carried out for this product in accordance with the Machinery Directive. The declaration of incorporation is set out in writing in a separate document and can be requested if required.

This machinery is incomplete and must not be put into service until the machinery into which it is to be incorporated has been declared in conformity with the applicable provisions of the Directive.

Nexen Group, Inc.  
560 Oak Grove Parkway  
Vadnais Heights, Minnesota 55127

ISO 9001 Certified

## Table of Contents

General Specifications .....	1
General Safety Precautions .....	1
Installation .....	2
Lubrication .....	3
Air Connections .....	4
Operation .....	5
Troubleshooting .....	5
Parts Replacement .....	6
Parts List .....	7
Warranty .....	8

## GENERAL SPECIFICATIONS

Specifications:	
Torque	Up to 11.3 Nm (100 in-lbs)
Actuation Pressure	1 - 5.5 bar (14.5 - 80 psi)
Service Temperature	4.5 - 104 C (40 - 220 F)
Approximate Weight	Up to 1.8 kg (4 lbs)

## GENERAL SAFETY PRECAUTIONS



**CAUTION**

Use appropriate guarding for moving components. Failure to guard could result in serious bodily injury.



**CAUTION**

Watch for sharp features when interacting with this product. The parts have complex shapes and machined edges.



**WARNING**

Ensure proper guarding of the product is used. Nexen recommends the machine builder design guarding in compliance with OSHA 29 CFR 1910 "Occupational Safety and Health Hazards."



**WARNING**

This product is capable of emitting a spark if misused, therefore is not recommended for use in any explosive environment.

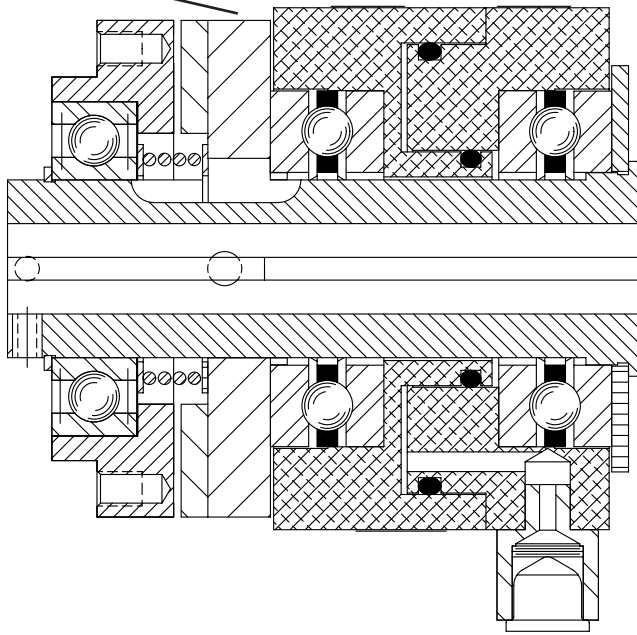



**CAUTION**

The temperature limits for this product are 4.5°-100° C (40°-220° F).



**CAUTION**

Use appropriate guarding for moving components. Failure to guard could result in serious bodily injury.

## INSTALLATION

### SHEAVE AND PILOT MOUNTING

#### REFER TO FIGURE 1.

1. Insert the Key (Item 21) into the keyway of the mounting shaft.
2. Slide the BW Clutch onto the mounting shaft until the Key (Item 21) is seated in the BW Clutch.
3. Insert and tighten the two Set Screws (Item 20).

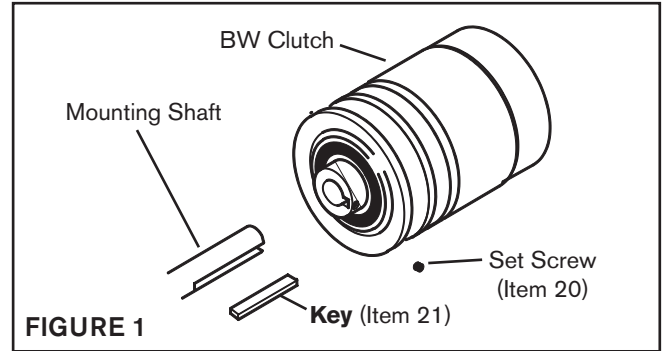

### COUPLING MOUNTING

#### REFER TO FIGURE 2.

1. Insert the Key (Item 21) into the keyway of the mounting shaft.
2. Slide the Pilot Mount BW Clutch onto the mounting shaft until the Key (Item 21) is seated in the Pilot Mount BW Clutch.
3. Insert and tighten the two Set Screws (Item 20).
4. Insert the customer supplied key into the coupling shaft.
5. Slide the Coupling Adapter onto the coupling shaft.
6. Using the Cap Screws provided with the Coupling Adapter, secure the Coupling Adapter to the Pilot Mount BW Clutch.
7. Insert and tighten the Set Screws provided with the Coupling Adapter.

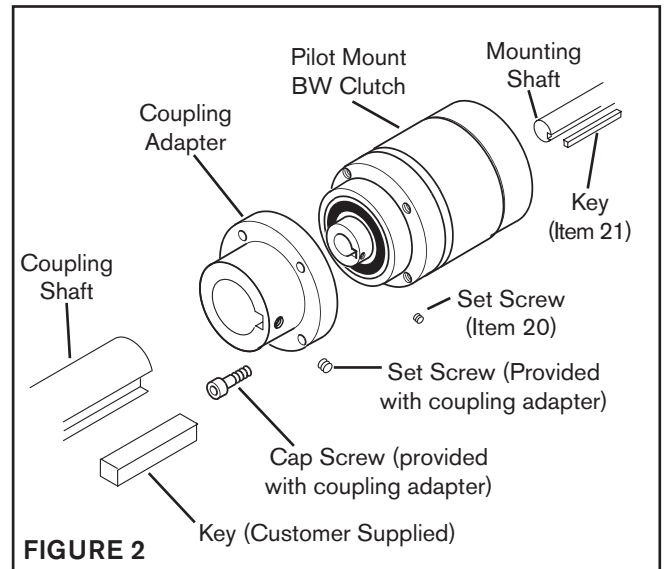

### BRAKE MOUNTING

#### REFER TO FIGURE 3.

1. Using the Cap Screws provided with the Brake Adapter, secure the Brake Adapter to the Pilot Mount BW Clutch.
2. Insert the Key (Item 21) into the keyway of the mounting shaft.
3. Slide the Pilot Mount BW Clutch with the Brake Adapter onto the mounting shaft and Key.
4. Align the notch in the Brake Adapter with a torque pin or stop on the machine.
5. Insert and tighten the two Set Screws (Item 20).

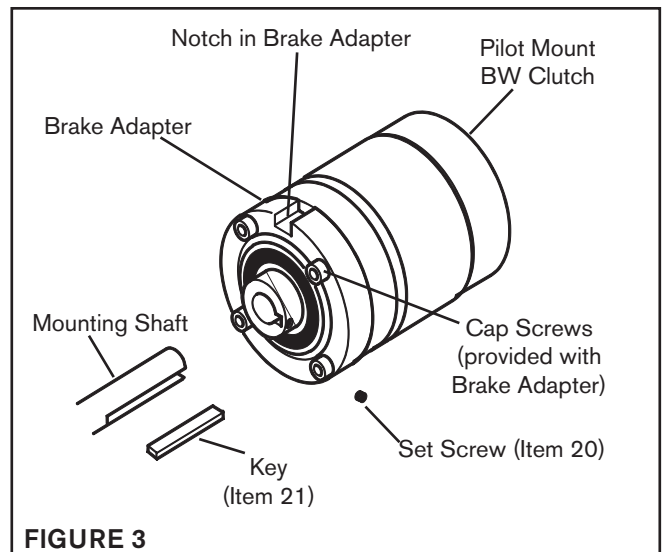

## LUBRICATION

### NOTE

Nexen pneumatically actuated devices require clean, pressure regulated air for maximum performance and life. All seals in Nexen pneumatically operated devices are lubricated for life, and do not require additional lubrication.

However, some customers prefer to use an air line lubricator, which injects oil into the pressurized air, forcing an oil mist into the air chamber. This is acceptable, but care must be taken to ensure once an air mist lubrication system is used, it is continually used over the life of the product as the oil mist may wash free the factory installed lubrication.

Locate the lubricator above and within ten feet of the product, and use low viscosity oil such as SAE-10.

Synthetic lubricants are not recommended.

Nexen product's bearings are shielded and pre-lubricated, and require no further lubrication.

### LUBRICATOR DRIP RATE SETTINGS

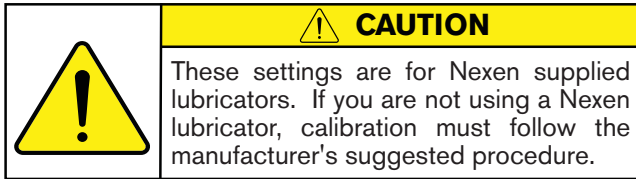

1. Close and disconnect the air line from the unit.
2. Turn the Lubricator Adjustment Knob counterclockwise three complete turns.
3. Open the air line.
4. Close the air line to the unit when a drop of oil forms in the Lubricator Sight Gage.
5. Connect the air line to the unit.
6. Turn the Lubricator Adjustment Knob clockwise until closed.
7. Turn the Lubricator Adjustment Knob counterclockwise one-third turn.
8. Open the air line to the unit.

## AIR CONNECTIONS

A 1/8 NPT female Air Inlet Fitting (Item 18) is provided in the Piston (Item 13) for the air line connection. The Air Hose Assembly (Item 19) must be used so that no side forces are introduced to the air chamber-piston assembly.

Bearing drag on the hose during operation may be relieved by securing the hose to a support.

All Nexen pneumatically actuated devices require clean and dry air, which meets or exceeds ISO 8573.1:2001 Class 4.4.3 quality.

### NOTE

**For quick response, Nexen recommends a quick exhaust valve and short air lines between the Control Valves and the unit. Align the air inlet ports to a down position to allow condensation to drain out of the air chambers of the product.**



### CAUTION

Low air pressure will cause slippage and overheating. Excessive air pressure will cause abrupt starts and stops, reducing product life.





### CAUTION

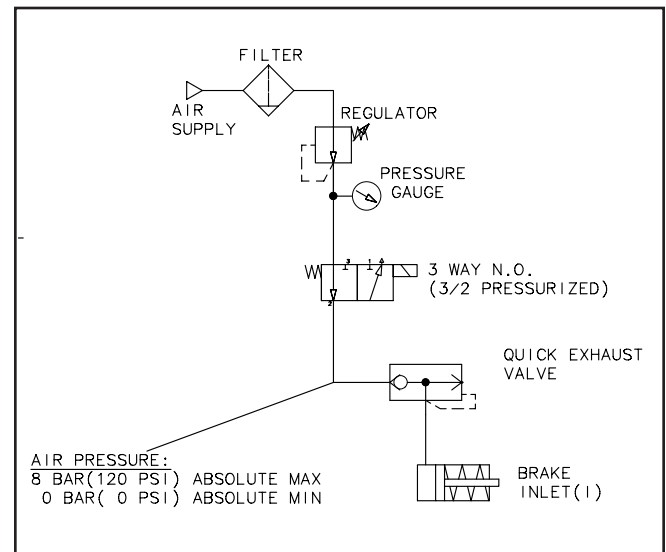

The use of rigid pipe or tubing when connected directly to the BW Clutch will prevent proper actuation of the BW Clutch.



The following is a common air supply scheme used with this product. This is an example and not an all-inclusive list. All air circuits to be used with this product must be designed following EN983 guidelines.



## OPERATION

	 <b>WARNING</b>
	Never exceed maximum operating speeds listed for your product (See Table 1).

	 <b>CAUTION</b>
	The temperature limits for this product line are 4.5° - 100° C (40°-220° F).

	 <b>WARNING</b>
	Ensure proper guarding of the product is used. Nexen recommends the machine builder design guarding in compliance with OSHA 29 CFR 1910 "Occupational Safety and Health Hazards."



	 <b>CAUTION</b>
	Never exceed life of facing material. Facing life depends on the volume of material and the total energy over the life of the unit. Expected life (in hrs) can be found by: Time= $\frac{\text{Volume}}{(\text{Power} \cdot \text{Wear Rate})}$

TABLE 1

Size	Max RPM
BW	3,600

## TROUBLESHOOTING

SYMPTOM	PROBABLE CAUSE	SOLUTION
Failure to engage	Air not getting to the clutch due to a control valve malfunction or low air pressure.	Check control valve and air pressure setting.
	Defective O-ring Seals causing air leaks.	Replace O-ring Seals.
	Lack of lubrication on the Hub spline or in the air chamber.	Lubricate the Hub spline with a thin film of Never Seez® or check air line lubricator settings.
	Rigid pipe or tubing for air line connections.	Use flexible pipe or tubing for all air line connections.
Failure to disengage	Friction lock due to a lack of lubrication on the Hub spline or in the air chamber.	Lubricate the Hub spline with a thin film of Never Seez® or check air line lubricator settings.
	Broken Return Spring	Install a new Return Spring.
	Unexhausted air due to a control valve malfunction.	Check or replace control valve.
Excessive drag on the air line	Defective Bearings	Replace Bearings.
	Air line is not properly supported.	Rest the air line against a support that is parallel to the center line of the clutch.



## PARTS REPLACEMENT

### REFER TO FIGURE 4.

1. Remove the Retaining Ring (Item 2).
2. Depending on which version of the BW Clutch is being used, remove the Pilot Mount Disc (Item 15) or the Sheave (Item 4).
3. Press the old Bearing (Item 3) out of the Sheave or Pilot Mount Disc.
4. Clean the bearing bore of the Sheave (Item 4) or Pilot Mount Disc (Item 15) with fresh solvent making sure all old Loctite® residue is removed.
5. Apply an adequate amount of Loctite® RC609 to evenly coat the outer race of new Bearing (Item 3).
6. Carefully align the outer race of the new Bearing (Item 3) with the bore of the Sheave or Pilot Mount Disc and press the new Bearing (Item 3) into place.
7. Remove the first old Spring Retaining Washer (Item 23), old Return Spring (Item 5), and the second old Spring Retaining Washer (Item 23) from the Hub (Item 1).
8. Slide the old Friction Disc Assembly (Item 7) off of the Hub (Item 1).
9. Remove the old Disc Key (Item 6).
10. Slide the Hub (Item 1) out of the Air Chamber (Item 9) and Piston (Item 13).
11. Separate the Piston (Item 13) from the Air Chamber (Item 9).
12. Remove the old O-ring Seal (Item 11) from the Air Chamber (Item 9).
13. Press the old Thrust Bearing (Item 8) out of the Air Chamber (Item 9).
14. Carefully align the outer race of the new Thrust Bearing (Item 8) with the bore of the Air Chamber (Item 9) and press the new Thrust Bearing (Item 8) into place.
15. Remove the old O-ring Seal (Item 10) from the Piston (Item 13).
16. Press the old Thrust Bearing (Item 8) out of the Piston (Item 13).
17. Carefully align the outer race of the new Thrust Bearing (Item 8) with the bore of the Piston (Item 13) and press the new Thrust Bearing (Item 8) into place.
18. Clean the O-ring contact surfaces of the Air Chamber and Piston with fresh safety solvent.
19. Coat the O-ring contact surfaces of the Air Chamber and Piston with fresh O-ring lubricant and wipe off any excess lubricant.
20. Coat the new O-ring Seals (Items 10 and 11) with fresh O-ring Lubricant.
21. Install the new O-ring Seals (Items 10 and 11).
22. Slide the Piston (Item 13) into Air Chamber (Item 9).
23. Slide the Air Chamber and Piston onto Hub (Item 1).
24. Install the new Disc Key (Item 6) into the Hub.
25. Slide new Friction Disc Assembly (Item 7) onto the Hub (Item 1) and Disc Key (Item 6).
26. Install the new Return Spring (Item 5) and Spring Retaining Washers (Item 23).
27. Press the Pilot Mount Disc (Item 15) and Bearing (Item 3) or the Sheave (Item 4) and Bearing (Item 3) onto the Hub (Item 1).
28. Reinstall the Retaining Ring (Item 2).

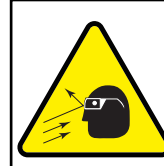

### CAUTION

Working with spring loaded or tension loaded fasteners and devices can cause injury. Wear safety glasses and take the appropriate safety precautions.

**NOTE: The closed end of the Return Spring (Item 5) must face toward the Retaining Ring (Item 2).**

## PARTS LIST

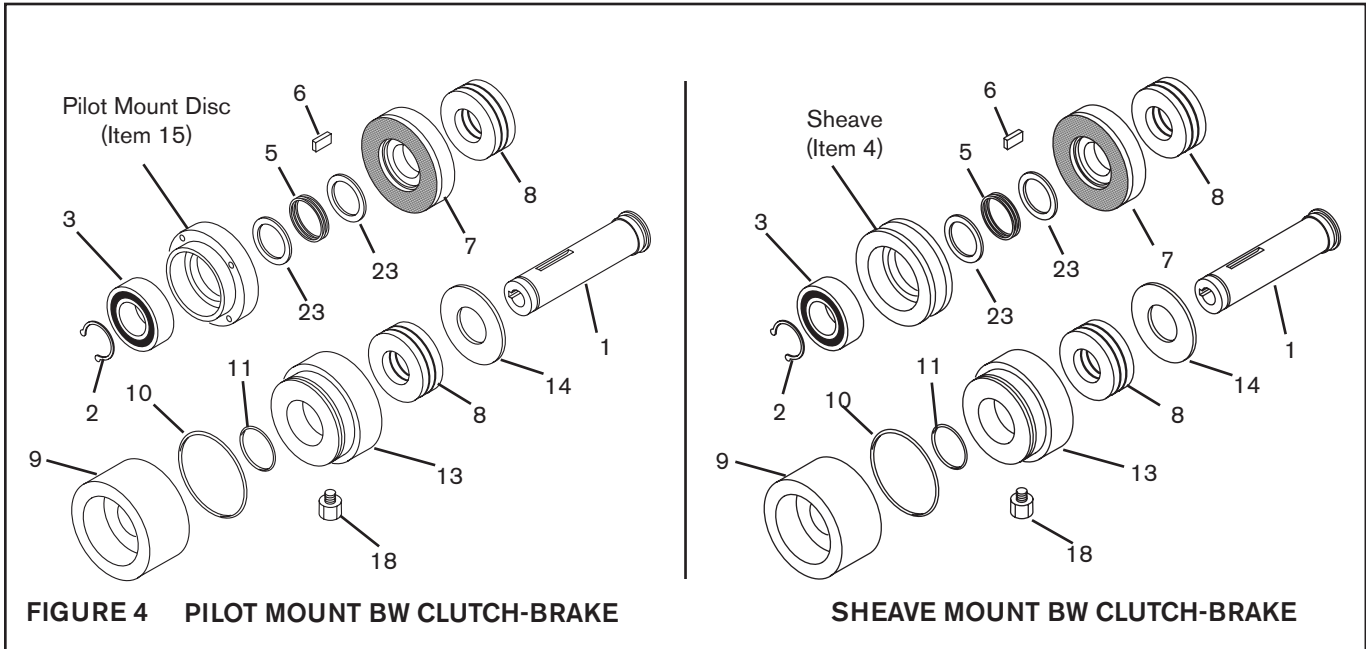

ITEM	DESCRIPTION	QTY
1	Hub	1
2	Retaining Ring (Ext.)	1
3	Bearing	1
4	Sheave	1
5 <sup>1</sup>	Return Spring	1
6 <sup>1</sup>	Disc Key	1
7 <sup>1</sup>	Friction Disc Assembly	1
8 <sup>1</sup>	Thrust Bearing	2
9	Air Chamber	1
10 <sup>1</sup>	O-Ring Seal (Large)	1
11 <sup>1</sup>	O-Ring Seal (Small)	1
13	Piston	1
14	Washer	1
15	Pilot Mount Disc	1
18	Air Inlet Fitting	1
19	Air Hose Assembly (Not Shown)	1
20	Set Screw (Not Shown)	2
21	Key (Not Shown)	1
23 <sup>1</sup>	Spring Retaining Washer	2

<sup>1</sup> Denotes Repair Kit Item (Repair Kit No. 846800)

## WARRANTY

### Warranties

Nexen warrants that the Products will (a) be free from any defects in material or workmanship for a period of 12 months from the date of shipment, and (b) will meet and perform in accordance with the specifications in any engineering drawing specifically for the Product that is in Nexen's current product catalogue, or that is accessible at the Nexen website, or that is attached to this Quotation and that specifically refers to this Quotation by its number, subject in all cases to any limitations and exclusions set out in the drawing. NEXEN MAKES NO OTHER WARRANTY, EXPRESS OR IMPLIED, AND ALL IMPLIED WARRANTIES, INCLUDING WITHOUT LIMITATION, IMPLIED WARRANTIES OF MERCHANTABILITY AND FITNESS FOR A PARTICULAR PURPOSE ARE HEREBY DISCLAIMED. This warranty applies only if: (a) the Product has been installed, used and maintained in accordance with any applicable Nexen installation or maintenance manual for the Product; (b) the alleged defect is not attributable to normal wear and tear; (c) the Product has not been altered, misused or used for purposes other than those for which it was intended; and (d) Buyer has given written notice of the alleged defect to Nexen, and delivered the allegedly defective Product to Nexen, within one year of the date of shipment.

### Exclusive Remedy

The exclusive remedy for the Buyer for any breach of any warranties provided in connection with this agreement will be, at the election of Nexen: (a) repair or replacement with new, serviceably used, or reconditioned parts or products; or (b) issuance of credit in the amount of the purchase price paid to Nexen by the Buyer for the Products.

### Agent's Authority

Buyer agrees that no agent, employee or representative of Nexen has authority to bind Nexen to any affirmation, representation, or warranty concerning the Products other than those warranties expressly set forth herein.

### Limitation on Nexen's Liability

TO THE EXTENT PERMITTED BY LAW NEXEN SHALL HAVE NO LIABILITY TO BUYER OR ANY OTHER PERSON FOR INCIDENTAL DAMAGES, SPECIAL DAMAGES, CONSEQUENTIAL DAMAGES OR OTHER DAMAGES OF ANY KIND OR NATURE WHATSOEVER, WHETHER ARISING OUT OF BREACH OF WARRANTY OR OTHER BREACH OF CONTRACT, NEGLIGENCE OR OTHER TORT, OR OTHERWISE, EVEN IF NEXEN SHALL HAVE BEEN ADVISED OF THE POSSIBILITY OR LIKELIHOOD OF SUCH POTENTIAL LOSS OR DAMAGE. For all of the purposes hereof, the term "consequential damages" shall include lost profits, penalties, delay damages, liquidated damages or other damages and liabilities which Buyer shall be obligated to pay or which Buyer may incur based upon, related to or arising out of its contracts with its customers or other third parties. In no event shall Nexen be liable for any amount of damages in excess of amounts paid by Buyer for Products or services as to which a breach of contract has been determined to exist. The parties expressly agree that the price for the Products and the services was determined in consideration of the limitation on damages set forth herein and such limitation has been specifically bargained for and constitutes an agreed allocation of risk which shall survive the determination of any court of competent jurisdiction that any remedy herein fails of its essential purpose.

### Inspection

Buyer shall inspect all shipments of Products upon arrival and shall notify Nexen in writing, of any shortages or other failures to conform to these terms and conditions which are reasonably discoverable upon arrival without opening any carton or box in which the Products are contained. Such notice shall be sent within 14 days following arrival. All notifications shall be accompanied by packing slips, inspection reports and other documents necessary to support Buyer's claims. In addition to the foregoing obligations, in the event that Buyer receives Products that Buyer did not order, Buyer shall return the erroneously shipped Products to Nexen within thirty (30) days of the date of the invoice for such Products; Nexen will pay reasonable freight charges for the timely return of the erroneously shipped Products, and issue a credit to Buyer for the returned Products at the price Buyer paid for them, including any shipping expenses that Nexen charged Buyer. All shortages, overages and nonconformities not reported to Nexen as required by this section will be deemed waived.

### Limitation on Actions

No action, regardless of form, arising out of any transaction to which these terms and conditions are applicable may be brought by the Buyer more than one year after the cause of action has accrued.

**nexen**<sup>®</sup>

Nexen Group, Inc.  
560 Oak Grove Parkway  
Vadnais Heights, MN 55127

800.843.7445  
Fax: 651.286.1099  
www.nexengroup.com

ISO 9001 Certified  
FORM NO. L-20002-U-1209