

Wall Mounted DMX512 Master SR-2830BDMX(US)



Feature

- Backlight
- Glass interface(White & Black)
- Touch sensitive
- Adjust brightness & color temperature



Parameter

Part No.	Input Voltage	Output	Size	Remarks
SR-2830BDMX(US)	12-24VDC	DMX512 Signal	120x75x29.1	Touch Sensor

Product Size

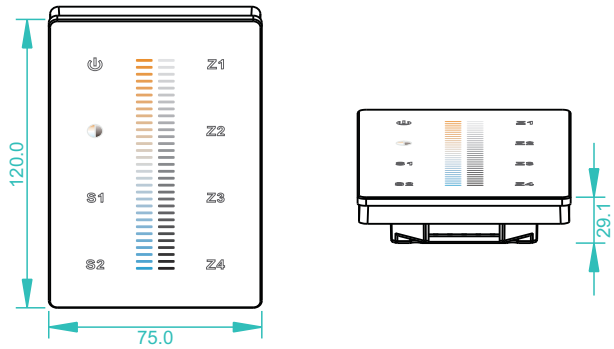

Installation

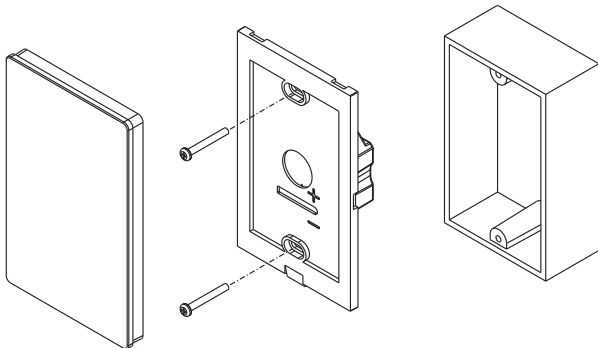

Wiring diagram

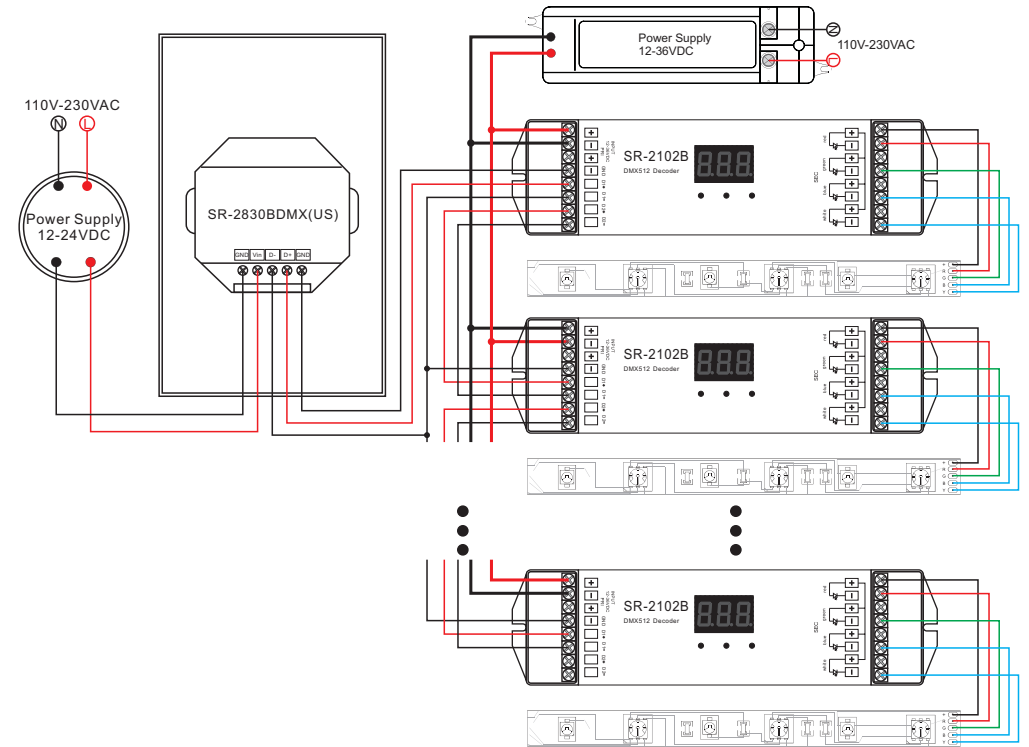

Description of buttons

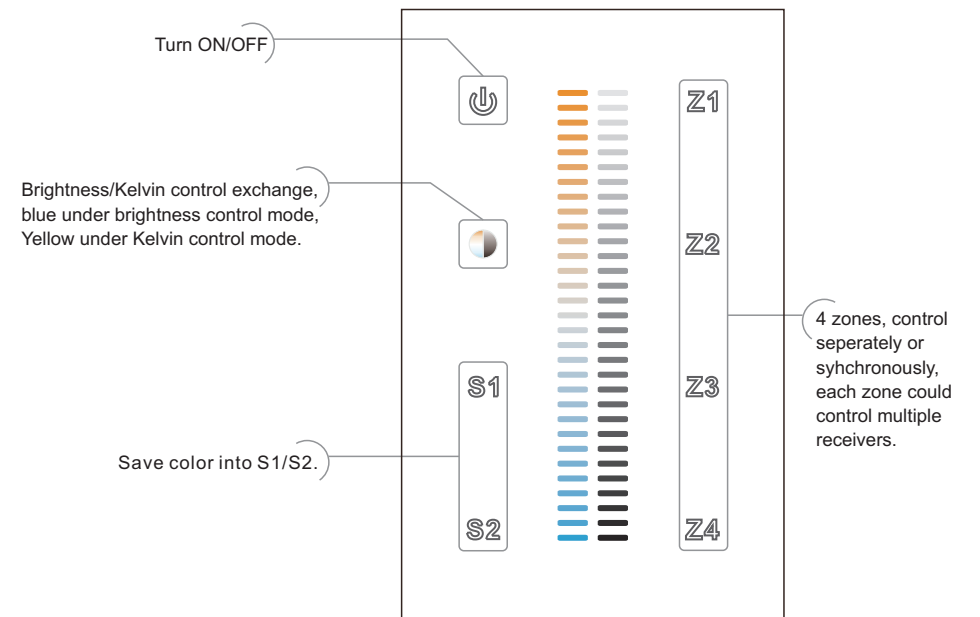

Operation

1. Switch
Touch on/off button, all zones on/off. Blue when playing. Yellow when off.
Once turn on, the default setting is under brightness control mode
Touch zone button Z1/Z2/Z3/Z4 separately over 2 seconds, which will turn ON/OFF separately.
The backlight blue is ON for the zone, yellow is OFF for the zone.
2. Save and recall
Save: Touch color slider to get a color→
Hold any button of S1 or S2 over 2 seconds under 4 zones work together
The light flick means successfully saved.
Recall: Short touch button S1 or S2 →Recall the color saved.

Safety & Warnings

- 1) The product shall be installed and serviced by a qualified person.
- 2) IP20. Please avoid the sun and rain. When installed outdoors, please ensure it is mounted in a water proof enclosure.
- 3) Always be sure to mount this unit in an area with proper ventilation to avoid overheating.
- 4) Please check if the output voltage of any LED power supplies used comply with the working voltage of the product.
- 5) Never connect any cables while power is on and always assure correct connections to avoid short circuits before switching on.
- 6) Please ensure that the cable is secured tightly in the connector
- 7) For update information please consult your supplier.

Warranty Agreement

- 1) We provide lifelong technical assistance with this product:
 - 5-year warranty. We print date on every products, for example :1125 means year 2011, week 25. The warranty is for free repair or replacement and covers manufacturing faults only.
 - For faults beyond the 3-year warranty we reserve the right to charge for time and parts.
- 2) Limited Warranty
 - Any defects caused by wrong operation.
 - Any damages caused by unauthorized removal, maintenance, modifying, incorrect connection and replacement of chips.
 - Any damages due to transportation, vibration etc. after purchase.
 - Any damages caused by earthquake, fire, lightning, pollution and abnormal voltage.
 - Any damages caused by negligence, inappropriate storing at high temperatures and humidity or near harmful chemicals.
 - Product has been updated
- 3) Repair or replacement as provided under this warranty is the exclusive remedy to the customer.