

*USER MANUAL*

# **OLC/OLCT 20**

**Gas Detector**



Part Number: NPO20GB  
Revision: C.2

**OLDHAM**  
The Fixed Gas Detection Experts

# GAS DETECTION

We are delighted that you have chosen an **OLDHAM** instrument and would like to thank you for your choice.

We have taken all the necessary measures to ensure that your instrument provides total satisfaction.

Now it is important to read this document carefully.

## EXTENT OF RESPONSIBILITY

- \* **OLDHAM** declines its responsibility towards any person for material damage, physical injury or death resulting wholly or partly from inappropriate use, installation or storage of its equipment resulting from failure to observe instructions and warnings and/or standards and regulations in force.
- \* **OLDHAM** neither supports nor authorises any company, physical or moral person to assume responsibility on behalf of **OLDHAM**, even if it is involved in the sale of **OLDHAM** products.
- \* **OLDHAM** cannot be held responsible for direct or indirect damage or be required to pay direct or indirect compensation resulting from the sale or use of any of its products **IF THESE PRODUCTS HAVE NOT BEEN DEFINED AND CHOSEN BY OLDHAM FOR THEIR SPECIFIC USE.**

## CLAUSES CONCERNING PROPERTY

- \* Drawings, plans, specifications and information included in this document contain confidential information that is the property of **OLDHAM**.
- \* None of this information may be reproduced, copied, divulged or translated, by physical, electronic or any other means, nor used as the basis for the manufacture or sale of **OLDHAM** equipment or for any other reasons **without prior consent from OLDHAM.**

## WARNINGS

- \* This document is not contractually binding. In the interests of its customers, **OLDHAM** reserves to modify the technical specifications of its equipment without notice, in order to improve its performance.
- \* **READ THIS MANUAL CAREFULLY BEFORE FIRST USE OF THE EQUIPMENT:** this manual must be read by any person who is or will be responsible for using, maintaining or repairing this equipment.
- \* **This equipment will only provide the announced performance levels if it is used, maintained and repaired according to OLDHAM directives, by OLDHAM personnel or by personnel approved by OLDHAM.**

## GUARANTEE

2 years guarantee in normal conditions of use on parts and technical labour, return in our workshops, excluding consumables (sensors, filters, etc.)

# CONTENTS

<b>1</b>	<b>Description .....</b>	<b>5</b>
1.1	General.....	5
1.2	Main characteristics of the various versions.....	5
1.3	Mechanical installation of the various versions.....	6
<b>2</b>	<b>Wiring arrangements.....</b>	<b>7</b>
2.1	3-Wire version (OLC 20d, OLCT 20d) .....	7
2.2	2-wire versions (OLCT 20d).....	7
2.3	2-wire Intrinsic Safety versions (OLCT 20i) .....	8
<b>3</b>	<b>Maintenance.....</b>	<b>9</b>
3.1	Detector OLC 20.....	9
3.1.1	Calibration.....	9
3.1.2	Replacing a sensor on an OLC 20.....	10
3.2	Transmitters OLCT 20.....	10
3.2.1	Calibration.....	10
3.2.2	Calibration specifications.....	12
3.3	Replacing a sensor on OLCT 20.....	12
3.4	Disposal of OLC(T) 20 .....	12
<b>4</b>	<b>Spare Parts.....</b>	<b>13</b>
4.1	OLC 20 flameproof gas detector .....	13
4.2	OLCT 20 flameproof gas detector .....	13
4.3	OLCT 20 Intrinsic Safety detector.....	14
<b>5</b>	<b>Accessories .....</b>	<b>15</b>
<b>6</b>	<b>Technical characteristics of OLC 20 .....</b>	<b>17</b>
<b>7</b>	<b>Technical characteristics of OLCT 20.....</b>	<b>17</b>
<b>8</b>	<b>Specific Instructions for use in Explosive Atmospheres according to European Directive ATEX 94/9/EC .....</b>	<b>19</b>
8.1	Specifications for mechanical and electrical installation in Classified Areas. ....	19
8.1.1	Flameproof detectors (d).....	19
8.1.2	Intrinsic safety detectors (i) OLCT 20 i.....	19

8.2	Metrological specifications for explosive gas and oxygen measurement detectors ...	20
8.2.1	Technical Specifications and Special Instructions for explosive gas detectors ....	21
8.2.2	Technical Specifications and Special Instructions for Oxygen detectors .....	25
8.3	Markings .....	26
8.3.1	Flameproof certified version: OLC 20d and OLCT 20 d.....	26
8.3.2	Intrinsic safety version: OLCT 20 i .....	26
<b>9</b>	<b>Recommendations .....</b>	<b>27</b>
<b>10</b>	<b>EC Declaration of Conformity .....</b>	<b>29</b>

# 1 Description



## 1.1 General

---

**OLC 20** gas detectors are catalytic type detectors intended for the detection of combustible gases. They are flameproof certified (OLC 20d).

**OLCT 20** gas detectors are 4-20 mA transmitters and are intended for the measurement of combustible and toxic gases and oxygen. They are either flameproof certified (OLCT 20d) or intrinsically safe certified (OLCT 20i).

**OLC 20s** and **OLCT 20s** are available in ¾ NPT or M25 screw fittings and are designed to be attached on a junction box or any compatible generic transmitters.

## 1.2 Main characteristics of the various versions

---

	OLC 20		OLCT 20	
	<i>LEL</i>		<i>LEL</i>	<i>TOX/O2</i>
Flameproof design	X		X	X
Intrinsic safety design				X
3-wire cable / Wheatstone bridge	X			
3-wire cable / 4-20 mA output			X	
2-wire cable / 4-20 mA output				X
Catalytic sensor	X		X	
Electrochemical sensor				X
Replaceable sensor	X			
Replaceable and pre-calibrated sensor			X	X

### 1.3 Mechanical installation of the various versions

---

Please ensure you read the paragraph: Special Specifications for use in Potentially Explosive Atmospheres in Accordance with European Directive ATEX 94/9/EC

See **Appendix 1** for general installation instructions.

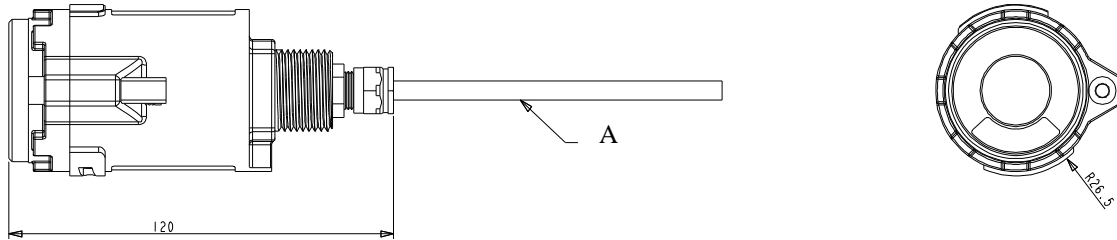

**Figure 1 : Dimensions**

	A
Dimensions OLC/OLCT 20	Cable length 0.2 m

## 2 Wiring arrangements

Please ensure you read the paragraph: Special Specifications for use in Potentially Explosive Atmospheres in Accordance with European Directive ATEX 94/9/EC

### 2.1 3-Wire version (OLC 20d, OLCT 20d)

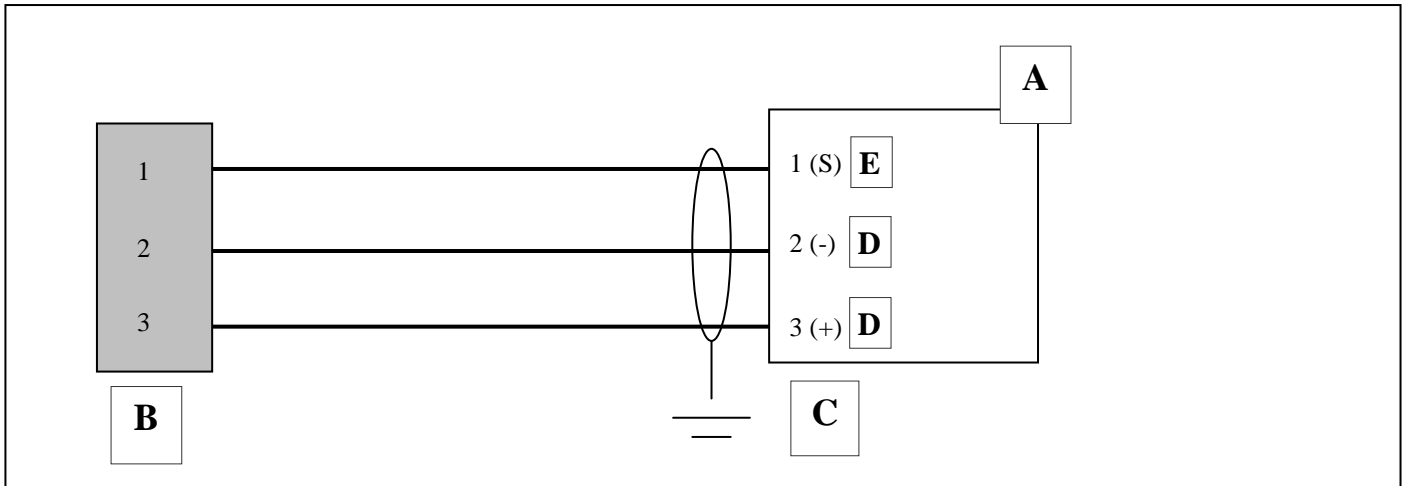

Figure 2

A	B	C	D	E
OLDHAM controller	OLC or OLCT 20	Grounding	Power supply	Signal (I)

### 2.2 2-wire versions (OLCT 20d)

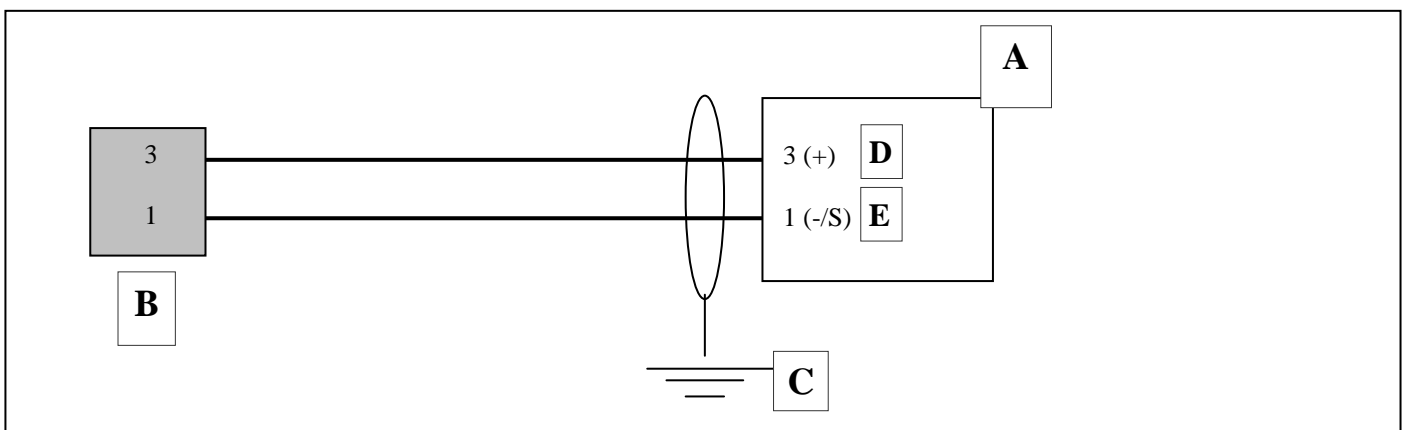

Figure 3

A	B	C	D	E
OLDHAM controller	OLC 20 or OLCT 20	Grounding	Power supply	Power supply Signal

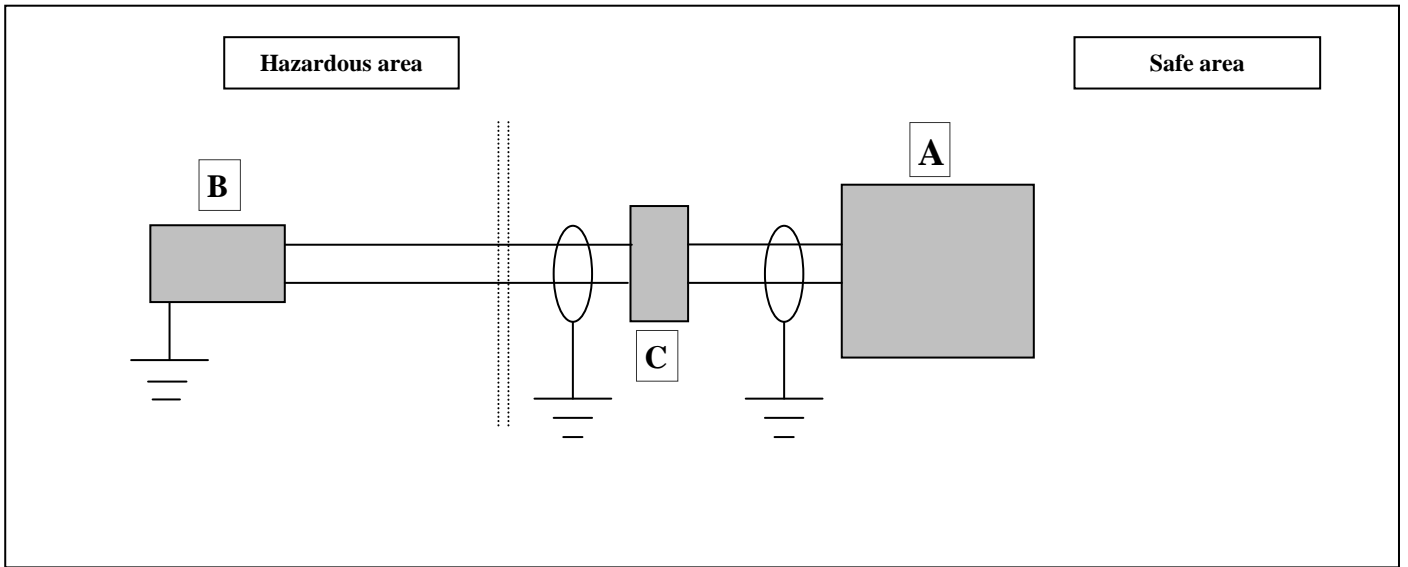

Figure 4

A	B	C
OLDHAM controller	OLC 20 or OLCT 20	ZENER Barrier



# 3 Maintenance



The operations and adjustments described in this chapter must be performed by authorized personnel only as they can affect the appliance's reliability in detection.

It is prohibited to open the transmitter when energized

## 3.1 Detector OLC 20

Gas detection instruments are potential life-saving devices. Recognizing this fact, OLDHAM Corporation recommends that a functional “bump” test be performed on every fixed gas-monitoring instruments as part of a regular maintenance program. A functional test is defined as a brief exposure of the detector to a concentration of gas(es) in excess of the lowest alarm set-point for each sensor for the purpose of verifying sensor and alarm operation and is not intended to be a measure of the accuracy of the instrument.

OLDHAM further recommends that a full instrument calibration be performed using a certified concentration(s) of calibration gas(es) quarterly, every 3 months.\* Calibrations may be necessary more or less frequently based, for example, on application, field conditions, exposure to gas, sensor technology, and environmental conditions. The frequency of calibration is best determined by company policy or local regulatory agencies.

If an instrument fails to operate properly during any functional “bump” test, a full instrument calibration should be performed successfully prior to use.

These recommendations are based on safe work procedures, industry best practises, and regulatory standards to ensure worker safety. OLDHAM is not responsible for setting safety practices and policies.

*\* For new installations it may be prudent to carry out bump tests frequently at first (perhaps weekly), increasing the time intervals (to, perhaps, monthly or more) as confidence grows with experience in the installation concerned, on the basis of the maintenance record.*

### 3.1.1 Calibration

On the controller	On the detector
<p>Set the measuring channel to the calibration position (alarm relays inhibited)</p> <p style="text-align: right;">└─┬─&gt;</p>	
<p>Proceed the zero and span</p> <p style="text-align: center;">↓</p> <p>Set the measuring channel back to the "normal" position and make sure that it is working properly.</p>	<p>Apply the calibration cup and perform the calibration in accordance with the procedure defined during the training course provided by OLDHAM or by an OLDHAM's authorized person</p> <p style="text-align: left;">←┬─┘</p>

### **3.1.2 Replacing a sensor on an OLC 20**

#### **When?**

- When the sensor is damaged or cannot be calibrated
- On a preventive basis

#### **How?**

- Turn off the relevant measuring channel
- Remove the sensor to be replaced
- Replace it with a new sensor
- Turn on the channel back and check that it operates correctly  
(see the following page for more information)

## **3.2 Transmitters OLCT 20**

---

OLCT 20 gas transmitters are equipped with a pre-calibrated sensor and do not require any adjustment on installation.

However, as gas detectors are safety equipment, it is recommended to bump test the complete transmitter after a sensor replacement.

### **3.2.1 Calibration**

After removing the sensor from the transmitter, perform the calibration by using the calibrating bench provided for that purpose (see CALIBRO's user manual).

# Procedure

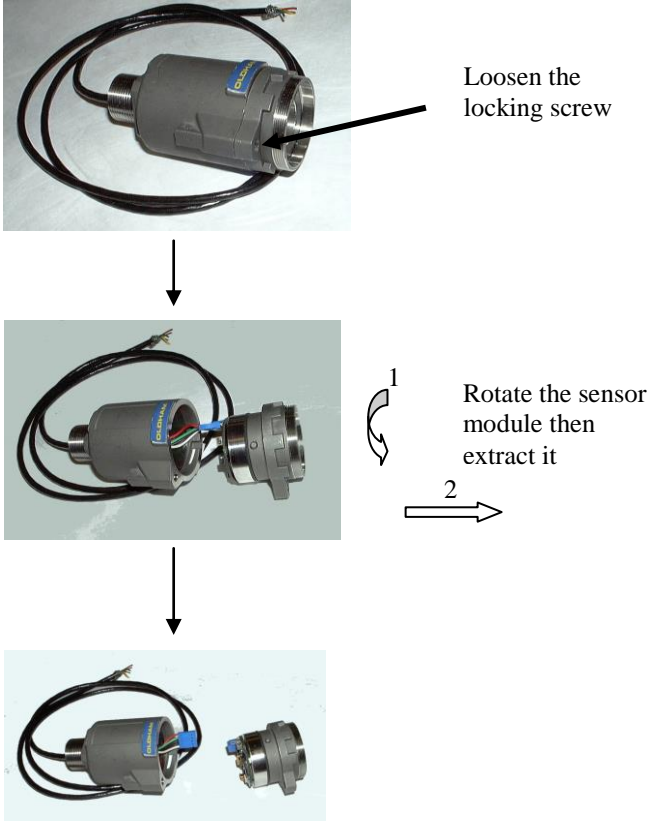
<b>On the controller</b>	<b>On the detector</b>
<p>Set the measuring channel to the calibration position (alarm relays inhibited)</p> <p>Set the measuring channel back to the "normal" position and make sure that it is working properly.</p>	 <p>Loosen the locking screw</p> <p>1 Rotate the sensor module then extract it</p> <p>2</p> <p>Once calibrated put the sensor back in place or use a replacement sensor and reinstall the whole assembly.</p>

### 3.2.2 Calibration specifications



Calibration shall be performed **outside classified areas** and by using **suitable equipment** that is described during the training course provided by OLDHAM or by a person authorized by OLDHAM.

#### OLCT 20 sensor module (LEL/TOX/O<sub>2</sub>)

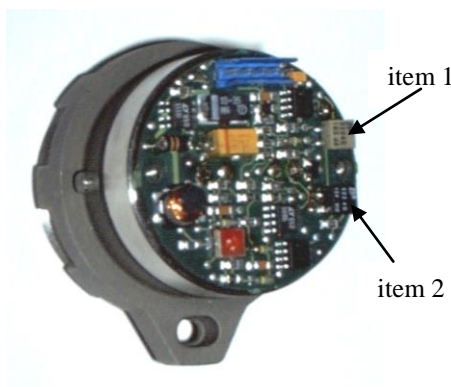

- Adjustment of 0 in clean air, using potentiometer (item 1).
- Adjustment of sensitivity (with standard gas), using the potentiometer (item 2).

### 3.3 Replacing a sensor on OLCT 20

#### When?

- When the sensor is damaged or cannot be calibrated.
- On a preventive basis.

#### How?

- Switch off the relevant measuring channel.
- Remove the sensor to be replaced.
- Replace it with a new, precalibrated unit.
- Switch the channel back on and check that it operates correctly.

### 3.4 Disposal of OLC(T) 20

Concerning the conservation, of the protection and the improvement of the quality of the environment, as well as for the protection of the health of the persons and the careful and rational use of natural resources, OLCT 20 has to be the object of a selective collection for the electronic equipments and cannot be scrapped with the normal domestic waste. The user thus has the obligation to separate the OLCT 20 of the other waste so as to guarantee that it is recycled in a sure way at the environmental level. For more details of the existing sites of collection, contact the local administration or the distributor of this product.

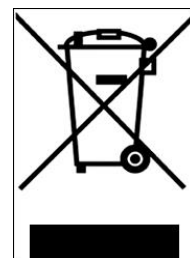

## 4 Spare Parts



Use only genuine spares, otherwise the reliability of the equipment could be adversely affected

### 4.1 OLC 20 flameproof gas detector

Flameproof replacement sensors	Part number
Replacement sensor (VQ1 – standard)	6313757
Replacement sensor (AP – poison resistant)	6313758
Catharometric sensor	6313759

### 4.2 OLCT 20 flameproof gas detector

Flameproof replacement sensors	Part number
OLCT 20, 0-100% LEL (VQ1)	6313685
OLCT 20, 0-100% LEL (AP)	6313974
OLCT 20, 0-100% vol. (catharometer)	6313687
OLCT 20 CO, 0 – 100 ppm	6313690
OLCT 20 CO, 0 – 300 ppm	6313691
OLCT 20 CO, 0 - 1000 ppm	6313692
OLCT 20 H2S, 0 – 30 ppm	6313695
OLCT 20 H2S, 0 – 100 ppm	6313696
OLCT 20 H2S, 0 - 1000 ppm	6313697
OLCT 20 NO, 0 – 100 ppm	6313698
OLCT 20 NO, 0 – 300 ppm	6313699
OLCT 20 NO, 0 - 1000 ppm	6313700
OLCT 20 H2, 0 - 2000 ppm	6313706
OLCT 20 NH3, 0 – 100 ppm	6313707
OLCT 20 NH3, 0 - 1000 ppm	6313708
OLCT 20 O2, 0 - 0–30% vol.	6313710

### 4.3 OLCT 20 Intrinsic Safety detector

---

INTRINSIC SAFETY SENSORS (SI)	Part number
OLCT 20 CO, 0 – 100 ppm	6313711
OLCT 20 CO, 0 – 300 ppm	6313712
OLCT 20 CO, 0 - 1000 ppm	6313713
OLCT 20 H2S, 0 – 30 ppm	6313716
OLCT 20 H2S, 0 – 100 ppm	6313717
OLCT 20 H2S, 0 - 1000 ppm	6313718
OLCT 20 NO, 0 – 100 ppm	6313719
OLCT 20 NO, 0 – 300 ppm	6313720
OLCT 20 NO, 0 - 1000 ppm	6313721
OLCT 20 NO2, 0 – 10 ppm	6313722
OLCT 20 NO2, 0 – 30 ppm	6313723
OLCT 20 SO2, 0 – 10 ppm	6313724
OLCT 20 SO2, 0 – 30 ppm	6313725
OLCT 20 SO2, 0 - 100 ppm	6313726
OLCT 20 H2, 0 – 2000 ppm	6313727
OLCT 20 NH3, 0 – 100 ppm	6313728
OLCT 20 NH3, 0 - 1000 ppm	6313729
OLCT 20 HCl, 0 – 30 ppm	6313730
OLCT 20 HCl, 0 - 100 ppm	6313731
OLCT 20 HCN, 0 – 30 ppm	6313732
OLCT 20 HCN, 0 - 100 ppm	6313733
OLCT 20 Cl2, 0 – 10 ppm	6313734
OLCT 20 O3, 0 – 1 ppm	6313735
OLCT 20 COCl2, 0 – 1 ppm	6313736
OLCT 20 PH3, 0 – 1 ppm	6313737
OLCT 20 AsH3, 0 – 1 ppm	6313738
OLCT 20 HF, 0 – 10 ppm	6313739
OLCT 20 ClO2, 0 – 3 ppm	6313740
OLCT 20 ETO, 0 – 30 ppm	6313746
OLCT 20 SiH4, 0 – 50 ppm	6313747
OLCT 20 O2, 0 – 30% vol.	6313748

## 5 Accessories

<b>TOOL KIT</b>	6147869	
<b>CALIBRATION CUP</b>	6331141	
<b>BY-PASS ADAPTOR</b> for combustible gases, CO, H <sub>2</sub> S, O <sub>2</sub>	6327910	
<b>PLASH GUARD</b>	6329004	
<b>PROTECTIVE FILTER, PTFE</b>	6335975	
<b>ACTIVE CARBON FILTER</b>	6335976	
<b>REMOTE CALIBRATION CUP</b> (for combustible gases only)	6327911	





## 6 Technical characteristics of OLC 20

<b>Power supply:</b>	voltage on detector terminals = 2.8 V max
<b>Power consumption:</b>	3-wire version = 400 mA max
<b>Measurement signal:</b>	Wheatstone bridge
<b>Line length (shielded cable):</b>	3-wire version = 1 km as 3x 1.5 mm <sup>2</sup> (32 ohms in loop mode)
<b>Output signal</b>	mV bridge output, 3 wires
<b>Ingress Protection</b>	IP66
<b>Weight</b>	800 g
<b>Dimensions</b>	60 X 120 mm

## 7 Technical characteristics of OLCT 20

### A) Explosion-proof version

<b>Power supply:</b>	voltage on detector terminals = 15 V to 30 V
<b>Power consumption:</b>	3-wire version = 100 mA 2-wire version = 25 mA
<b>Load resistance:</b>	maximum resistance = 250 ohms
<b>Line length (shielded cable):</b>	3-wire version = 1 km as 3x 1.5 mm <sup>2</sup> (32 ohms in loop mode) 2-wire version = 4 km as 3x 1.5 mm <sup>2</sup> (32 ohms in loop mode)

### B) Intrinsic safety version

Characteristics of ZENER barrier:	28 V - 300 ohms
Supply voltage for barrier:	19 V to 26 V
Voltage on detector terminals:	10 V to 26 V
Power consumption:	25 mA max
Load resistance:	47 ohms
Line length (shielded cable):	1 km as 3x 1.5 mm <sup>2</sup> (32 ohms in loop mode)

### Output signal

Source mode current	4-20 mA
Max. current	25 mA
Fault current	<1 mA

### Miscellaneous

Ingress Protection	IP66
Weight	800 g
Dimensions	60 X 120 mm



## 8 Specific Instructions for use in Explosive Atmospheres according to European Directive ATEX 94/9/EC

The OLC/OLCT 20 gas detectors comply with the requirements of European Directive ATEX 94/9/EC relating to explosive Dust and Gas atmospheres.

As a result of their metrological performance, as tested by the Approval Agency INERIS, the OLC/OLCT 20 gas detectors designed to measure explosive gasses and oxygen are classified as safety devices and may therefore contribute to limiting the risk of explosion.

The information contained in the following paragraphs should be respected and taken into account by the manager of the site where the equipment is installed. Please refer to the provisions of European Directive ATEX 1999/92/EC on improving health and safety conditions for workers exposed to potentially explosive atmospheres.

### 8.1 Specifications for mechanical and electrical installation in Classified Areas.

Installation will comply with all applicable standards, and particularly with EN 60079-14 and EN 60079-17.

#### 8.1.1 Flameproof detectors (d)

- These detectors are intended for use in surface industries II, Category 2, zones 1 and 2 (Gas) and zones 21 and 22 (Dust) in ambient temperature from  $-20^{\circ}\text{C}$  to  $+70^{\circ}\text{C}$ .
- Cables will be mechanically protected.
- The transmitter casing will be earthed using the external or internal terminal, which should be corrosion-protected. Users should clean detectors regularly in order to prevent any external accumulation of dust.
- Mechanically, detectors will be installed such that the detection sensor points downwards. Any variance of over  $45^{\circ}$  from the vertical will result in measurement errors.
- Where connections are located in a classified zone, they will be enclosed in approved envelopes.
- The width of the threaded joint of cable gland is superior to the value specified in the table of EN 60079-1 standard.

#### 8.1.2 Intrinsic safety detectors (i) OLCT 20 i

- These detectors are intended for use in surface industries II, Category 1, zones 0, 1 and 2 (Gas) and zones 20, 21 and 22 (Dust). They are also intended for use in coal mines, Category M1. The ambient operating temperature range is  $-20^{\circ}\text{C}$  to  $+70^{\circ}\text{C}$ .
- Users should clean detectors regularly in order to prevent any external accumulation of dust.
- The person responsible for IS installation (the "System Designer") must draw up a system document demonstrating that every aspect of the Power Cable Detector system complies with intrinsic safety.
- They must be powered by an intrinsic safety source: 28V - 300 ohms
- Where connections are located in a classified zone, they will be enclosed in approved envelopes.
- The safety parameters applying to the OLCT 20i detectors are :

Ui (V)	Ii (mA)	Pi (mW)	Ci (nF)	Li (H)
28	94	658	40	15 $\mu$ H

## 8.2 Metrological specifications for explosive gas and oxygen measurement detectors

---



**In case of exposure above the measuring range, it is mandatory to bump test the instrument with gas and/or to perform a calibration.**

**In the event of a change of position, it is necessary to re-calibrate the detector.**

---

The OLC/OLCT 20 transmitter sensors intended to measure explosive gasses and oxygen are classified as safety devices and may therefore contribute to limiting the risk of explosion.

Detectors comply with the following European standards:

### **Explosive gas detectors:**

- OLC 20 explosive gas detectors comply with European standards EN 50054 and EN 50057 for Methane (calibration gas), Propane and Hydrogen (gasses following response curves) where they are used with the following OLDHAM controllers SV 4B, MX 15, MX 32, MX 42A, MX 43, MX 48 and MX 52.
- OLCT 20 explosive gas detectors comply with European standards EN 50054 and EN 50057 for Methane (calibration gas), Propane and Hydrogen (gasses following response curves), where they are used with SV 4B, MX 15, MX 32, MX 42A, MX 43, MX 48, MX 52 and MX 62 OLDHAM controllers, or where they are connected to measurement devices with 4-20 mA inputs in accordance with paragraph 1.5 of Appendix II of the ATEX 94/9/EC Directive and are compatible with their characteristics (cf. transfer curve).

### **Oxygen detectors:**

- OLCT 20 oxygen detectors comply with European Standard EN 50104 where they are used with MX 15, MX 32, MX 42A, MX 43, MX 48, MX 52 and MX 62 OLDHAM controllers, or where they are connected to measurement devices with 4-20 mA inputs in accordance with paragraph 1.5 of Appendix II of the ATEX 94/9/EC Directive and are compatible with their characteristics (cf. transfer curve).

## 8.2.1 Technical Specifications and Special Instructions for explosive gas detectors

### 8.2.1.1 Transfer curves for OLCT 20 detectors

The following curve shows transmitter output current values as a function of gas concentration. Where the user connects the transmitter to a device other than a device manufactured by OLDHAM, he must check that the transfer curve is fully compatible with its input characteristics to ensure that the information generated by the transmitter is correctly interpreted. Equally, the device must supply a suitable power supply voltage, allowing for cable voltage losses.

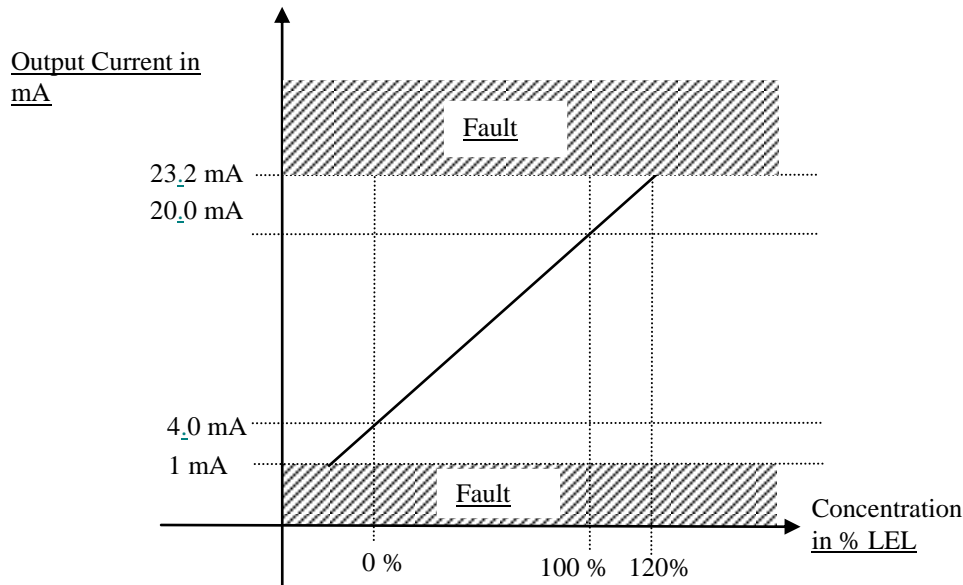

**Please note:** Detectors can generate ambiguous measurements at high gas concentrations, i.e. the current output for a > 20% concentration of gas by volume is the same as for a concentration of < 5% by volume (bell curve). It is therefore essential that the measuring device memorises the fact that the value has exceeded the scale and that resetting is manual rather than automatic, and follows the safety regulations specific to the site.

<b>Type</b>		VQ1			
<b>Maximum concentration</b>		100% LEL			
<b>Principle</b>		Catalytic			
<b>Estimated service life</b>		> 36 months			
<b>Storage</b>		Away from air $-10^{\circ}\text{C} < T < 35^{\circ}\text{C}$ 10% < RH < 60%. Maximum 6 months			
<b>Continuous temperature range</b>		$-20^{\circ}\text{C}$ to $+55^{\circ}\text{C}$			
<b>Humidity range</b>		0% RH to 95% RH			
<b>Pressure range</b>		1 bar $\pm$ 10%			
<b>Linearity variance (methane scale)</b>		Between 0% and 70% LEL: $\leq$ 1% LEL Between 70% and 100% LEL: $\leq$ 7% LEL			
<b>Measurement reproducibility</b>		$\pm$ 2% of the value measured, or $\pm$ 1 LEL (or $\pm$ 0.05% CH <sub>4</sub> )			
<b>Long-term drift in normal operating conditions</b>	Zero point:	< 5% methane LEL per year			
	Sensitivity: Methane Propane/Butane	Typical drift values < 20% of the value measured per year < 10% of the value measured per year			
<b>Effect of humidity (10% to 90% RH) at 40°C</b>		$\pm$ 5% of relative sensitivity			
<b>Maximum recommended interval between calibrations (normal operating conditions)</b>		6 months			
<b>Calibration concentration</b>		30– 80% LEL			
<b>Response time</b> (may vary $\pm$ 10% between sensors)	<b>gas and concentration injected</b>	Methane (50% LEL)	Hydrogen (50% LEL)	Pentane (52% LEL)	Styrene (45% LEL)
	<b>t25</b>	4 sec	3 sec	8 sec	12 sec
	<b>t50</b>	8 sec	6 sec	12 sec	40 sec
	<b>t90</b>	15 sec	10 sec	27 sec	60 sec

### 8.2.1.3 Special precautions for explosive gas detectors

- Sensors are sensitive to certain poisons, which can reduce their sensitivity: emission of silicone-containing vapours at concentrations > 10 ppm and chlorinated or sulphurous products at concentrations > 100 ppm.
- A lack of oxygen (< 15% O<sub>2</sub>) or over-oxygenation (> 23% O<sub>2</sub>) may cause under-measurement (in the former case) or over-measurement (in the latter case).
- Sensors must be located head downwards at installation or during maintenance work.

### 8.2.1.4 Response to other explosive gasses

It is recommended that the detector is calibrated using the gas to be measured. Users wishing to calibrate the detector using a gas other than detected and factory-programmed should refer to the following table, and use the recommended gas and corresponding coefficient.

**Table 1 : Calibration Coefficients**

Gas	Chemical Formula	LEL (%)	LSE (%)	Flash point (°C)	Vapor density	Coefficient Calibration gas CH4 (methane)	Coefficient Calibration gas H2 (Hydrogen)	Coefficient - Calibration gas C4H10 (Butane)	Coefficient - Calibration gas C5H12 (Pentane)
Ethyl acetate	C4H8O2	2,10	11,50	-4	3,0	1,65	1,35	0,90	0,80
Acetone	C3H6O	2,15	13,00	-18	2,1	1,65	1,35	0,90	0,80
Acetylene	C2H2	1,50	100	-18	0,9	2,35	1,90	1,25	1,15
Acrylic acid	C3H4O2	2,40	8,00	54	2,5	5,00	4,00	2,65	2,40
Butyl acrylate	C7H12O2	1,20	8,00	37	4,4	3,50	2,80	1,85	1,70
Ethyl acrylate	C5H8O2	1,70	13,00	-2	3,5	3,05	2,45	1,65	1,50
Acrylonitrile	C3H3N	2,80	28,00	-1	1,8	1,45	1,20	0,80	0,70
Ammoniac	NH3	15,00	30,20	< -100	0,6	0,90	0,75	0,50	0,45
Benzene	C6H6	1,20	8,00	-11	2,7	4,00	3,20	2,15	1,90
1.3-Butadiene	C4H6	1,40	16,30	-85	1,9	2,55	2,05	1,35	1,25
Butane	C4H10	1,50	8,50	-60	2,0	1,90	1,55	1,00	0,90
Butanol (Butyl Alcohol)	C4H10O	1,4	11,3	29	2,6	1,95	1,60	1,05	0,95
2 - Butanone (MEK)	C4H8O	1,80	11,50	-4	2,5	3,90	3,15	2,10	1,90
Cyclohexane	C6H12	1,20	8,30	-17	2,9	2,00	1,60	1,10	1,00
Dimethylether	C2H6O	3,00	27,00	-41	1,6	1,80	1,45	0,95	0,90
Dodecane	C12H26	0,60	~6,0	74	5,9	4,00	3,20	2,15	1,90
Ethane	C2H6	3,00	15,50	135	1,0	1,50	1,20	0,80	0,75
Ethanol	C2H6O	3,30	19,00	13	1,6	2,15	1,75	1,15	1,05
Ether (Diethylether)	(C2H5)2O	1,70	36,00	-45	2,6	1,90	1,55	1,00	0,90
Ethylene	C2H4	2,70	34,00	-135	1,0	1,65	1,35	0,90	0,80
LPG	Prop+But	1,65	~9,0	< -50	1,9	1,90	1,55	1,00	0,90
Diesel	Melange	0,60	~6,0	55	> 4	3,20	2,60	1,70	1,55
Natural Gas	CH4	5,00	15,00	-188	0,6	1,05			
Heptane	C7H16	1,10	6,70	-4	3,5	2,20	1,80	1,20	1,05

Gas	Chemical Formula	LEL (%)	LSE (%)	Flash point (°C)	Vapor density	Coefficient Calibration gas CH4 (methane)	Coefficient Calibration gas H2 (Hydrogen)	Coefficient - Calibration gas C4H10 (Butane)	Coefficient - Calibration gas C5H12 (Pentane)
Hexane	C6H14	1,20	7,40	-23	3,0	2,10	1,70	1,15	1,00
Hydrogen	H2	4,00	75,60	-	0,069		1,00		
Isobutane	C4H10	1,50	8,40	-83	2,0	1,50	1,20	0,80	0,75
Isobutene	C4H8	1,60	10,00	<-10	1,9	2,20	1,80	1,20	1,05
Isopropanol	C3H8O	2,15	13,50	11,7	2,1	1,60	1,30	0,85	0,80
Kerosene (JP4)	C10 - C16	0,70	5,00	> 50	> 4	5,00	4,00	2,65	2,40
Methyl Methacrylate	C5H8O2	2,10	12,50	2	3,5	2,25	1,80	1,20	1,10
Methane	CH4	5,00	15,00	-188	0,55	1,00			
Methanol	CH3OH	5,50	44,00	11	1,1	1,40	1,15	0,75	0,70
Naphta	melange (Mixture)	0,90	5,90	> 44	> 4	3,50	2,80	1,85	1,70
Nonane	C9H20	0,70	5,60	31	4,4	4,40	3,55	2,35	2,10
Octane	C8H18	1,00	6,00	12	3,9	2,70	2,20	1,45	1,30
Ethylene Oxide	C2H4O	2,60	100	-20	1,5	2,10	1,70	1,15	1,00
Propylene oxide	C3H6O	1,90	37,00	70	2,0	2,35	1,90	1,25	1,15
Pentane	C5H12	1,40	8,00	-49	2,5				1,00
Propane	C3H8	2,00	9,5	-104	1,6	1,55	1,25	0,85	0,75
Propylene	C3H6	2,00	11,70	-107,8	1,5	1,65	1,35	0,90	0,80
Styrene	C8H8	1,1	8,00	31	3,6	6,30	5,05	3,35	3,00
Gasoline lead free	/	1,10	~6,0	21	3 à 4	1,80	1,45	0,95	0,90
Toluene	C7H8	1,20	7	5	3,1	4,00	3,20	2,15	1,90
Turpentine Oil	-	0,8	6,0	35	4,7	3,50	2,80	1,85	1,70
Triethyl amine	C6H15N	1,20	8	-15	3,5	2,05	1,65	1,10	1,00
White Spirit	melange (Mixture)	1,10	6,50	>30	> 4	3,50	2,80	1,85	1,70
Xylene	C8H10	1,00	7,60	25	3,7	4,00	3,20	2,15	1,90

Sensors with a grey background: gases recommended for calibrating the detector (VQ1)

Example (second row of table): calibration of an Acetone detector using 1% butane (by volume) as the calibrating gas.

Value to be displayed:

$$\frac{1\% \text{ (butane injected)} \times 100 \times 0.90 \text{ (Butane/Acetone coefficient)}}{1.5\% \text{ (butane LEL)}} = 60\% \text{ LEL}$$

**N.B.:**

- LELs vary depending on the source. Those values shown here are taken from European Standard EN 50054
- Coefficients are accurate to  $\pm 15\%$



## 8.2.2 Technical Specifications and Special Instructions for Oxygen detectors

### 8.2.2.1 Transfer curves for OLCT 20 detectors

The following curve shows the transmitter output current value as a function of gas concentration. Where the user connects the transmitter to a device other than a device manufactured by OLDHAM, he must check that the transfer curve is fully compatible with its input characteristics to ensure that the information generated by the transmitter is correctly interpreted. Equally, the device must supply a suitable power supply voltage, allowing for cable voltage losses.

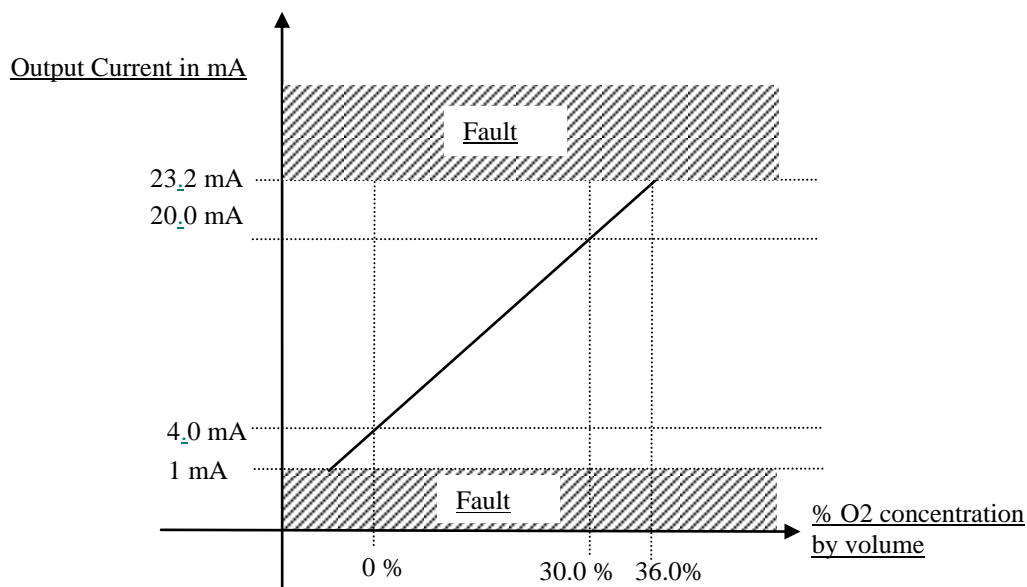

### 8.2.2.2 Metrological data

<b>Maximum concentration</b>	30% O <sub>2</sub>
<b>Type and number</b>	CT5020 CELL
<b>Principle</b>	2-electrode electrochemical (Measurement of oxygen concentration by volume)
<b>Estimated service life</b>	30 months
<b>Storage</b>	4°C < T < 12°C 10% < RH < 60%
<b>Temperature range</b>	-20°C to +45°C
<b>Humidity range</b>	20% RH to 95% RH
<b>Pressure range</b>	1 bar ± 10%
<b>Accuracy at 20°C</b>	15 to 21% O <sub>2</sub> ± 0.5% vol O <sub>2</sub> 1 to 14% O <sub>2</sub> ± 0.6% vol O <sub>2</sub>
<b>Repeatability</b>	< 2% of signal
<b>T90 response time</b>	< 15 seconds
<b>Effect of temperature (0 to 40°C)</b>	< 0.5% vol O <sub>2</sub>
<b>Effect of humidity (10% to 90% RH)</b>	The measurement is lower as a result of the air being diluted by water vapour
<b>Sensitivity drift over time</b>	< 2% per month
<b>Zero stabilisation time following power-up</b>	30 to 60 minutes

### 8.2.2.3 *Characteristics and Special precautions for oxygen detectors*

- When the transmitter is powered up or the measurement sensor is replaced, it takes between 30 and 60 minutes for the measurement to stabilise at 20.9% v/v in pure ambient air.
- The use of an oxygen-rich atmosphere (> 25%) can compromise safety.

## 8.3 **Markings**

---

### 8.3.1 **Flameproof certified version: OLC 20d and OLCT 20 d**

**OLDHAM**

**F – 62027 Arras**

**CE** 0080

OLC 20d or OLCT 20d



II 2GD

Ex d IIC T6 Gb

Ex tb IIIC T85°C Db IP66

Tamb : -20°C to 70°C

INERIS 01ATEX0004X

Read instruction manual

**WARNING:** Do not open when energized

Serial number, year of manufacture

### 8.3.2 **Intrinsic safety version: OLCT 20 i**

**OLDHAM**

**F – 62027 Arras**

**CE** 0080

OLCT 20i



II 1 GD

Ex ia IIC T4 Ga

Ex ia IIIC T135°C Da IP66

I M1 Ex ia I Ma

Tamb : -20°C to 70°C

INERIS 01ATEX0004X

Read instruction manual

**WARNING:** Do not open when energized

Serial number, year of manufacture

## 9 Recommendations

The measuring sensor shall be positioned facing downwards. The physical location of the TRANSMITTER depends on the type of gas to be detected:

- at the high point if the gas is lighter than air,
- at the low point if the gas is heavier than air,
- near outlet vents in the case of mechanical ventilation,
- or, more generally, in locations where the gas is likely to accumulate.

Despite its high degree of protection (IP66), it may be necessary to protect the TRANSMITTER against adverse weather conditions (rain, dust, direct sunlight, etc.) and from direct spraying with cleaning or maintenance products (causing soiling of the detection sensor).

The TRANSMITTER must also be positioned so as to allow access to the measuring sensor so that it can be replaced.

Detectors must be positioned so as to optimize the detection of accumulations of gas emitted in the air.

### **Factors to be considered in determining optimal detector positioning:**

⇒ potential sources of gas and vapour emissions

⇒ chemical and physical data on gases and vapours which may be present

⇒ liquids with low volatility ⇒ detectors as near as possible to the leak risk area

⇒ type and concentration of gas leaks (high-pressure jet, slow leak, etc.)

⇒ air movements

- indoors: natural and mechanical ventilation
- outdoors: wind speed and direction

⇒ effect of temperature

⇒ installation so as to avoid mechanical damage or deterioration caused by water in summer

⇒ positioning to allow easy maintenance, if possible

⇒ avoiding direct sunlight on the readout area as this would lead to maintenance problems



# 10 EC Declaration of Conformity



## DECLARATION DE CONFORMITE CONSTRUCTEUR Manufacturer Declaration of Conformity



La Société Industrial Scientific Oldham, ZI Est 62000 Arras France, atteste que les  
The Company Industrial Scientific Oldham, ZI Est 62000 Arras France, declares that

### Détecteurs de gaz OLC 20 et OLCT 20 *Gas detectors OLC 20 and OLCT 20*

sont conformes aux exigences des Directives Européennes suivantes:  
comply with the requirements of the following European Directives:



#### I) Directive Européenne ATEX 94/9/CE du 23/03/94 : Atmosphères Explosives *European Directive ATEX 94/9/CE dated from 23/03/94: Explosive Atmospheres*

Normes harmonisées appliquées (règles de construction) EN 60079-0:2009, EN 60079-1:2007, EN 60079-11:2012  
Harmonised applied Standards (rules of construction) EN 60079-26:2007, EN 60079-31:2009

Normes appliquées (métrologie) EN 50104:2002 Exigences d'aptitude à la fonction des détecteurs d'oxygène  
Applied standards (metrology) (Performance requirements of detectors for oxygen)  
EN 50054:1998 Exigences d'aptitude à la fonction des détecteurs de gaz  
EN 50057:1998 inflammables (Performance requirements of detectors for  
flammable gases) - Méthane (Methane) - capteur (sensor)  
standard C1000

#### Marquage (marking)

OLC20d ou (or) OLCT20d  II 2 GD  
Ex d IIC T6 Gb  
Ex tb IIIC T85° C Db IP66  
T.Amb: -20° C to 70° C

OLCT20i  II 1 GD  I M1  
Ex ia IIC T4 Ga Ex ia I Ma  
Ex ia IIIC T135° C Da IP66 T. Amb: -20° C to 70° C

Attestation CE de Type du matériel INERIS 01ATEX0004X  
*EC type examination certificate*

Délivré par l'Organisme Notifié numéro 0080 INERIS, Parc Alata  
*Issue by Notified Body No. 0080* 60550 Verneuil-en-Halatte, France

Notification Assurance Qualité de Production INERIS 00 ATEX Q403  
*Notification of the Production QA*

Délivré par l'Organisme Notifié numéro 0080 INERIS, Parc Alata  
*Issue by Notified Body No. 0080* 60550 Verneuil-en-Halatte, France

Note : les OLC 20 et OLCT 20 sont compatibles avec les centrales de détection (are compatible with gas controllers) MX 15, MX 32, MX 42A, MX 43, MX 48, MX 52, MX 62 and WINGAS.

#### II) Directive Européenne CEM 2004/108/CE du 15/12/04: Compatibilité Electromagnétique *The European Directive EMC 2004/108/CEE of 15/12/2004: Electromagnetic compatibility*

Normes harmonisées appliquées EN 50270:2006 (type 1 et 2) CEM – Appareils de détection de gaz  
*(Harmonised applied Standards) EMC – Apparatus for the detection of gases*



**Sécurité de fonctionnement (Functional Safety)**

Normes appliquées **EN 50402**  
Applied Standards

L'analyse de fiabilité, objet du rapport INERIS n° CGR 74448 du 06 juillet 2006 a permis de déterminer le taux de défaillances dangereuses non détectées pour les OLC 20 et OLCT 20 pour gaz combustibles :  
*The reliability analysis, based on INERIS report n° CGR 74448 of 06 July 2006 has determined that the dangerous failure rate for OLC 20 and OLCT 20 for combustible gases is*

$$\lambda_{du} = 4.42 \cdot 10^{-2} \text{ par an (per year)}$$

Les détecteurs de gaz explosibles et d'oxygène type OLC 20 et OLCT 20 ont un niveau :  
*OLC 20 and OLCT 20 combustible and oxygen gas detectors are*

SIL 2 avec un intervalle de maintenance (Ti) de 3 mois au plus, **PFD<sub>avg</sub> = 0,55.10<sup>-2</sup>**  
*SIL 2 compliant with a maintenance interval no greater than 3 months*

SIL 1 avec un intervalle de maintenance (Ti) de 6 mois au plus, **PFD<sub>avg</sub> = 1,1.10<sup>-2</sup>**  
*SIL 1 compliant with a maintenance interval no greater than 6 months*

Note: Les taux de défaillances calculés ne sont valables que durant la durée de vie réelle des éléments sensibles (intervalle de temps limité, de l'ordre de 3 à 5 ans). Au-delà, de par le vieillissement des cellules de mesure, le taux n'est plus significatif. La norme EN50402 assume pour les modules simples comme les capteurs OLC 20 et OLCT20, une proportion effective de défaillance en sécurité (SFF) comprise entre 60 % et 90 %.

*Note: The calculated failure rates are only valid on the real lifetime of the sensitive elements (limited time, about 3 to 5 years). Beyond that, due to ageing of the measuring cells, the rate is not significant any more. The EN50402 standard assumes for the simple modules like OLC 20 and OLCT20 detectors, an effective Safety Failure Fraction (SFF) between 60% and 90%.*

Page 2 sur 2 (page 2 out of 2)

Arras, le 28/01/14

Michel Spellemaeker  
Director of Product Management



**Oldham S.A.S.**  
Z.I. EST - CS 20417  
62027 ARRAS Cedex - FRANCE  
www.oldhamgas.com

CE\_atex\_CEM\_olct20\_ind\_h





## **EUROPEAN PLANT AND OFFICES**

Z.I. Est – rue Orfila CS 20417 – 62027 Arras Cedex FRANCE  
Tél: +33 (0)3 21 60 80 80 – Fax: +33 (0)3 21 60 80 00  
Website: <http://www.oldhamgas.com>

AMERICAS  
Tel: +1-713-559-9280  
Fax: +1-281-292-2860  
[americas@oldhamgas.com](mailto:americas@oldhamgas.com)

ASIA PACIFIC  
Tel: +86-21-3127-6373  
Fax: +86-21-3127-6365  
[sales@oldhamgas.com](mailto:sales@oldhamgas.com)

EUROPE  
Tel: +33-321-608-080  
Fax: +33-321-608-000  
[info@oldhamgas.com](mailto:info@oldhamgas.com)

---