



Marvel 80RD

Installation  
Operation &  
Maintenance  
Instructions

An AGA Company

# STARTING OUT

---

## **Remove Packaging**

Your drawer refrigerator has been packed for shipment with all parts that could be damaged by movement securely fastened. Before installing the drawer refrigerator, be sure all packing materials and tape have been removed.

## **Important**

Save the carton packaging until your drawer refrigerator has been thoroughly inspected and found to be in good condition. If there is damage, the packaging will be needed as proof of damage sustained in transit.

## **Note to Customer**

This unit was carefully packed and thoroughly inspected before leaving our plant. Responsibility for its safe delivery was assumed by the carrier upon acceptance of the shipment. As directed on the side of the packaging carton, claims for loss or damage sustained in transit must be made on the carrier as follows:

## **Exterior Damage**

Make a thorough damage notation on the delivery receipt and have the driver acknowledge by signing and dating. Send a written request asking for an inspection report from the carrier representative and the date the inspection was requested. Retain the inspection report and receipt for filing of a claim.

## **Concealed Damage**

This must be reported to the carrier within fifteen days. Obtain an inspection report from the carrier. Retain the inspection report for filing of the claim. **DO NOT RETURN DAMAGED MERCHANDISE TO THE MANUFACTURER - FILE THE CLAIM WITH THE CARRIER.**

# INSTALLATION

## Select Location

The proper location will ensure peak performance of your drawer refrigerator. Choose a location away from heat and out of direct sunlight. Best performance will be maintained when installed within the following parameters:

Ideal Ambient Temperature Range*	
built-in	55-80°F
freestanding	55-90°F

\* Drawer Refrigerator will not perform correctly in ambient temperatures less than 55°F.

## Cabinet Clearance

Ventilation is required for the bottom front section of the unit where the grille is located. Keep this area open and clear of any obstructions. Adjacent cabinets and countertop can be installed on top, back and sides of the unit as long as grille and drawer access remain unobstructed. An opening of 30" is required between cabinets with a depth of 24".

Adjacent cabinets and countertop can be installed on top, back and sides of the unit as long as the grille and drawer access remain unobstructed. Ventilation is required for the bottom front section of the unit where the grille is located. Keep this area open and clear of any obstructions.

Make certain that the leveling legs supplied with the drawer refrigerator are installed according to the instructions. Leveling adjustments can be made by raising or lowering the glides on the bottom of the unit.

**⚠ WARNING**

**DISCONNECT POWER SOURCE BEFORE ADJUSTING LEVELING LEGS**

## Important Safety Issue

A cabinet "anti-tip" device is mounted to the back of your drawer refrigerator. If your installation is a built-in undercounter application, you do not need to apply this feature. If your installation is a free-standing application with no counter top directly above the top of the drawer refrigerator, you must apply this feature to prevent the unit from tipping forward when the drawers are pulled out. The "anti-tip" device is attached at the back of each cabinet. Please see installation instructions supplied with the "anti-tip" device.

## Electrical Connection

Check the serial nameplate for the correct power supply. Use only the electrical power supply specified on the serial nameplate. Do not use an extension cord.

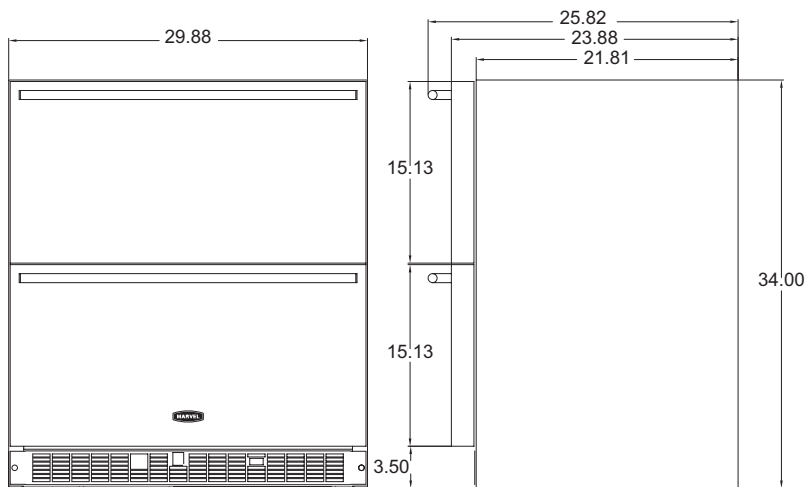

## Grounding Method

This drawer refrigerator is equipped with a power supply cord with ground. It must be plugged into a mating grounding type receptacle in accordance with the National Electrical Code and applicable local codes and ordinances. It is the customer's responsibility to provide the proper grounding type receptacle. Do not alter the plug in any way.

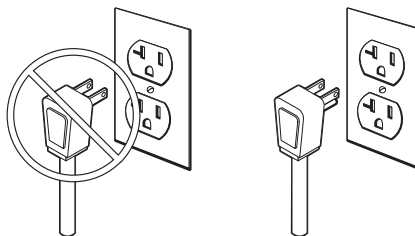

**⚠ WARNING**

**THIS UNIT SHOULD NOT, UNDER ANY CIRCUMSTANCES, BE UNGROUNDED.**

# FEATURES

---

## Control Panel

The temperature of your drawer unit ranges from 32°F to 47°F (0°C to 8°C). The temperature can be adjusted using the control panel located on the inside of the top drawer. To change the temperature setting, press the warmer or cooler pads until the display shows the desired temperature. After a few seconds the display will return to the actual temperature of the unit. An empty unit will stabilize in six to eight hours.

Your drawer refrigerator's control leaves the factory preset to display its temperature in degrees Fahrenheit. To change the display to show Celsius temperatures, simply press the warmer and cooler key pads simultaneously. The display will change within a few seconds.

The on/off key pad stops and starts the cooling of the unit. This can be used when your drawer refrigerator will not be used for extended periods of time. The LED light will continue to operate when the drawers are opened as long as the unit is connected to a power source.

At time of initial start up the control panel display will show "OR" or "Out of Range" until the unit reaches the desired temperature. At any time the unit's interior temperature reaches 9 degrees below or above its setpoint this code will also be displayed.

## TEMPERATURE CONTROL



COOLER



WARMER



## Gastronorm Container Systems

For additional convenience, optional Gastronorm food storage containers can be purchased from your dealer. These stainless steel containers can be used to easily access smaller food items and are dishwasher safe. For further information visit Marvel's website at: [www.marvelindustries.com](http://www.marvelindustries.com).

## Drawer Organizer

The Drawer Organizer is designed to be fully adjustable to compensate for bottles and other items of different sizes. The drawer Organizer can be adjusted left and right, up and down by turning the knob counter clockwise.

# CARE AND CLEANING OF YOUR DRAWER REFRIGERATOR

---

## Condenser

The condenser tubing inside the cabinet does not require frequent cleaning; however, satisfactory cooling depends on adequate ventilation over the coils. Be sure that nothing obstructs the required air flow openings in front of the cabinet. At least once or twice a year brush or vacuum lint and dirt from the grille. Also at least once or twice a year brush or vacuum lint and dirt from the condenser for efficient performance by unscrewing the grille on the bottom front of the cabinet.

## Interior

Clean the drawer gaskets as well as inside the drawers with mild soap and water. Do not use an abrasive powder, solvent, polish cleaner or undiluted detergent.

## Cabinet

The painted cabinet can be washed with mild soap and water and thoroughly rinsed with clear water. Never use abrasive scouring powders.

## Interior

Wash interior compartments with mild soap and water. Do not use an abrasive powder, solvent, polish cleaner or undiluted detergent.

## Door Gasket

The vinyl gasket may be cleaned with mild soap and water, a baking soda solution or a mild scouring powder.

## Care of Unit

1. Avoid leaning on the drawer fronts, you may bend the door hinge or tip the unit.
2. Exercise caution when sweeping, vacuuming, or mopping near the front of the unit. Damage to the grille can occur.
3. Periodic cleaning of the inside of the unit. (See Care and Cleaning of Your Drawer Refrigerator section).
4. Periodic checking and/or cleaning of the front grille and condenser coils as needed.

## Normal Responsibilities of the Owner

- All freight charges
- Damage sustained in transit
- Mileage charge(s) for service calls
- Proper installation including installation of leveling legs.
- Leveling of unit.
- Alterations to original equipment
- Cleaning and normal maintenance outlined in this manual.

## Help Prevent Tragedies

Each year, children die because they climb inside a discarded refrigeration product, get trapped inside and suffocate. Take precautions to prevent such tragedies by removing the door, taping or chaining it shut before discarding.

# FULL OVERLAY PANEL INSTALLATION INSTRUCTIONS

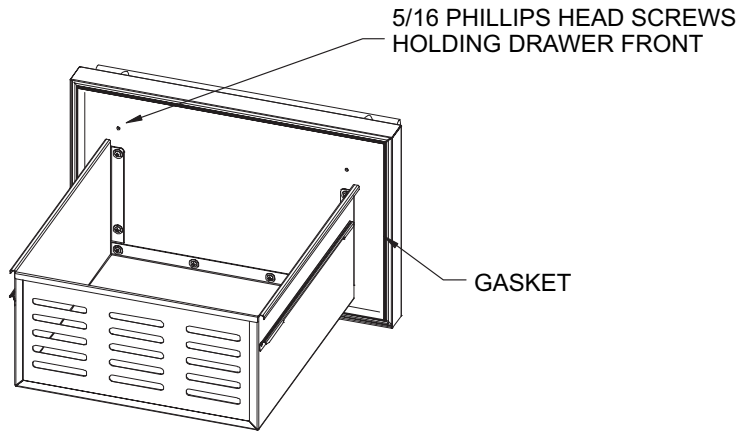

## Step 1:

### Wood Screws Required

1. A #8 pan head wood screw should be used to properly secure the overlay panel. A total of 10 screws will be needed.
2. Use only pan head screws.
3. Do not select a screw that is longer than the wood thickness at the screw locations.
4. Use recommended pilot holes for the frame material (see chart below).

Pilot Hole Drill Sizes for Wood Screws

	Wood Screw Size
Work Material	8
Hardwood	3/32
Softwood	5/64

## Step 2:

### Remove Drawer Fronts

(Note: The overlay panel may be installed without removing the drawer fronts from the drawer bodies, but the full drawer assembly is not as easy to handle as the drawer front alone.)

1. Remove drawer from unit. Begin by pulling out the drawer. Locate the drawer lock which can be found on the outside of the cabinet slide (fig. 1). Push the back of the drawer lock forward and then down, releasing the drawer from the cabinet slide (fig. 2). Repeat this on the opposite side of the drawer. Lift the drawer up from the slides at 90° to fully extricate the drawer from the cabinet (fig. 3).

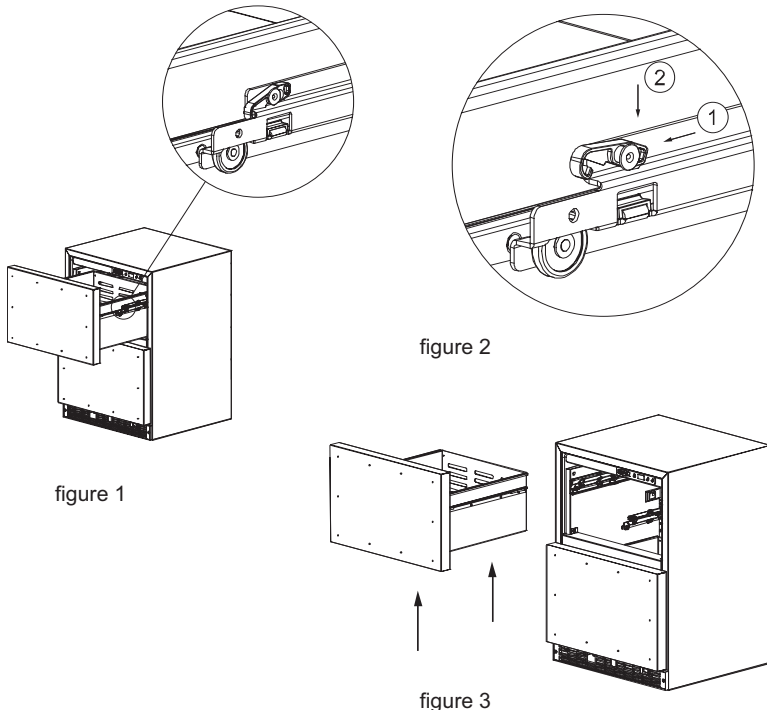

2. Remove drawer fronts. Do this by removing the 8 phillips screws and washers securing the drawer front to the drawer body. Mark lightly with an erasable marker the position of the stainless drawer liner as it secured to the stainless drawer before removing screws.

3. Remove the gasket from the drawer front. Do this by pulling the gasket out of the channel that holds it to the drawer front. This will expose the clearance holes for mounting the overlay panel.

# FULL OVERLAY PANEL INSTALLATION INSTRUCTIONS

---

## Step 3: Sizing the Overlay Panel

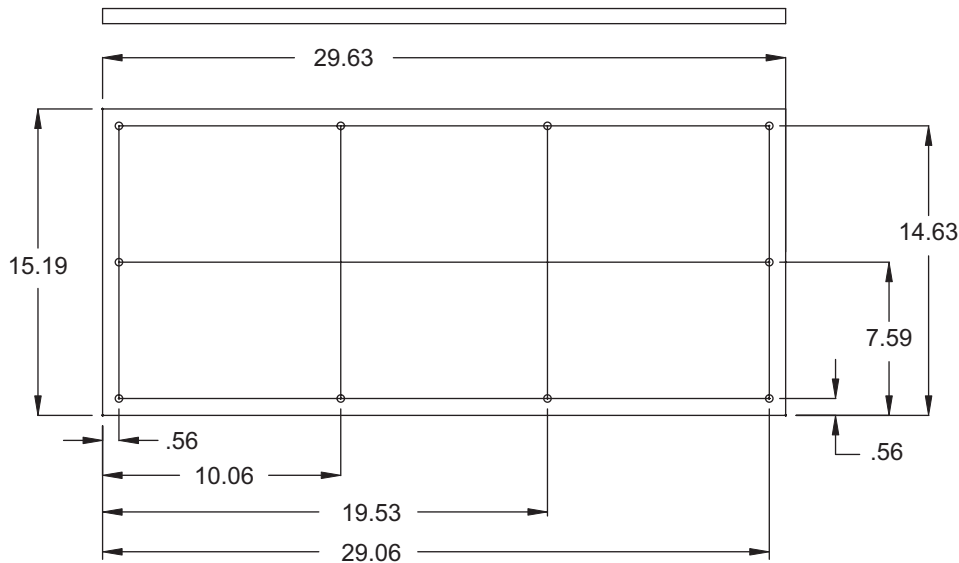

## Step 4: Attaching the Overlay Panel to the Door

1. Set overlay panel on drawer front face and align edges. Clamp panel in position and mark pilot hole locations. See step 3 for nominal size and hole locations. Drill pilot holes (remove panel if necessary, re-align and re-clamp overlay to drawer face).

2. Insert wood screws through clearance holes and tighten to secure overlay panel.

3. Reinstall gasket into channel. Make sure the corners are inserted fully.

## Step 5: Reattach Drawer Front to Drawer Body

1. Align mounting holes on drawer body with mounting holes on drawer front. Align the door liner to the front flanges by using the erasable marker alignment lines that were applied prior to removing the door from the drawer. Reinstall phillips head screws and washers. Snug down, but do not tighten fully, final adjustment of drawer front will be done after reinstalling the drawer.

## Step 6: Reinstall the Drawer

1. Fully extend drawer slides and place drawer on slides. Be sure that drawer sits evenly on both slides.

2. Lock drawers into drawer slides. Push drawer locks down and then back to relock the drawer into the slide.

## Step 7: Adjust Drawer Front

1. Adjust drawer front to achieve a 1/8" gap from the top of the drawer front to the top of the cabinet or (for bottom drawers) 1/8" from the top of the drawer front to the bottom of the top drawer, the drawer front should be centered between the cabinet edges.

2. Fully tighten phillips head screws.

# TROUBLESHOOTING

PROBLEM	POSSIBLE CAUSE	CORRECTION
Odor in cabinet	<ul style="list-style-type: none"> <li>Unit interior needs cleaned.</li> </ul>	<ul style="list-style-type: none"> <li>Clean inside of unit. See "Care and Cleaning" pg. 7.</li> </ul>
Noisy operation	<ul style="list-style-type: none"> <li>Unit not level.</li> </ul>	<ul style="list-style-type: none"> <li>Adjust leveling legs. See leveling leg instructions.</li> </ul>
Unit vibrates	<ul style="list-style-type: none"> <li>Unit not level.</li> <li>Weak floor.</li> </ul>	<ul style="list-style-type: none"> <li>Adjust leveling legs. See leveling leg instructions.</li> <li>Rebuild floor or move to a different location.</li> </ul>
Interior light not working	<ul style="list-style-type: none"> <li>LED light burned out.</li> <li>No power at outlet.</li> </ul>	<ul style="list-style-type: none"> <li>Replace LED light.</li> <li>Test outlet with lamp.</li> </ul>
Appliance will not run.	<ul style="list-style-type: none"> <li>Control Panel turned "OFF".</li> <li>Line Cord not plugged into power source.</li> <li>House fuse blown.</li> </ul>	<ul style="list-style-type: none"> <li>Turn unit on with on/off pad on Control Panel.</li> <li>Plug unit into power source.</li> <li>Reset house fuse.</li> </ul>
Appliance runs too long.	<ul style="list-style-type: none"> <li>Prolonged door openings.</li> <li>Control Panel set too cold.</li> <li>Condenser needs cleaning.</li> </ul>	<ul style="list-style-type: none"> <li>Reduce number and/or duration of door openings.</li> <li>Raise temperature of unit via Control Panel.</li> <li>Clean condenser. See "Care of Unit" pg 7.</li> </ul>
Moisture collects inside of unit	<ul style="list-style-type: none"> <li>Too many door openings.</li> <li>Prolonged door openings.</li> <li>Hot, humid weather increases condensation.</li> </ul>	<ul style="list-style-type: none"> <li>Reduce number and/or duration of door openings.</li> <li>Reduce number and/or duration of door openings.</li> <li>As humidity decreases, moisture will disappear.</li> <li>Move unit to cooler location.</li> </ul>
Moisture collects on outside surface of the unit.	<ul style="list-style-type: none"> <li>Hot, humid weather increases condensation.</li> <li>Control improperly set.</li> </ul>	<ul style="list-style-type: none"> <li>As humidity decreases, moisture will disappear.</li> <li>Move unit to cooler location.</li> <li>Reset to slightly warmer temperature.</li> </ul>
Interior too hot/too cold	<ul style="list-style-type: none"> <li>Control improperly set.</li> <li>Faulty thermometer.</li> </ul>	<ul style="list-style-type: none"> <li>Reset control to desired temperature.</li> <li>Recheck with second thermometer.</li> </ul>

## Diagnostic LED

In the back in the grille there is a diagnostic/status LED. This led is used to help diagnosis any problems with the unit and to tell its status.

LED Status	Code/Problem
Not on	Unit does not have power
Continuously on	Unit is "ON" and operating correctly
1 Blink and pause	For shorted or open thermistor
2 Blink and pause	Disconnected Display Board
3 Blink and pause	Compressor is locked out



# OBTAINING SERVICE

## Before Calling for Service

Before calling for service, check the following items:

- Make sure unit is plugged into outlet.
- Check the outlet for power. Test outlet with lamp to make certain outlet has power.
- Make sure drawer refrigerator is "ON". Display will show.
- Make certain unit is level from front to back and side to side.
- Use troubleshooting guide, page 7 for other diagnosis.

If you are not able to correct the problem, contact your dealer or the manufacturer. Be sure to have the model number and the serial number handy before you call. The model and the serial number are located somewhere on your drawer refrigerator.

## How to Obtain Service

Your drawer refrigerator requires little service because the best and most up-to-date materials, equipment and quality control methods are employed throughout the manufacturing process.

If trouble occurs during normal operation, read "Things to remember" section first and, if necessary, check the troubleshooting guide. If service becomes necessary:

1. Contact the dealer where your appliance was purchased or the manufacturer for the name of the nearest authorized service representative. The service representative will have full authority to make any repairs deemed necessary.
2. If you are in an area where there is no service representative, write or call the manufacturer directly. We will make recommendations as to the proper procedure for correction. Service work and replacement parts, if required, will be provided as covered by your limited warranty.

3. In all correspondence regarding service, be sure to give the model number, serial number and proof of purchase.
4. Try to have information or description of the nature of the problem, how long the unit has been running, the room temperature and any additional information that may be helpful in quickly solving the problem.

Every new drawer refrigerator that leaves the factory contains this Owner's Guide. Keep this Owner's Guide in a safe place for convenient reference.

 **IMPORTANT**

SEND IN YOUR WARRANTY RECORD CARD  
IMMEDIATELY AFTER TAKING DELIVERY OF  
YOUR DRAWER REFRIGERATOR.

## For Your Records

<hr/> <i>Date of Purchase</i>		
<hr/> <i>Dealer's Name</i>		
<hr/> <i>Dealer's Address</i>		
<hr/> <i>Dealer's city</i>	<hr/> <i>Dealer's State</i>	<hr/> <i>Zip</i>
<hr/> <i>Appliance Serial Number</i>		
<hr/> <i>Model Number</i>		
<hr/> <i>Date Warranty Card Mailed (within 10 days of purchase)</i>		

# WARRANTY

---

## Entire Product

### Limited One Year Parts and Labor Warranty

Marvel warrants that it will supply all necessary parts and labor to repair or replace in the end user's home or office, any component which proves to be defective in material or workmanship, subject to the condition and exclusions stated below, for a period of one year from the date of purchase by the end user.

### Additional Second Through Fifth Year

#### Limited Parts Only Warranty

During the four years following expiration of the one year limited warranty, Marvel will supply replacement parts for the hermetically sealed refrigeration system which consists of the compressor, condenser, drier, accumulator, by-pass valve, connecting tubing and the evaporator that are proven to be defective due to workmanship or materials subject to the conditions and exclusions below.

The above warranties do not cover:

- Shipping costs of replacement parts or returned defective parts.
- Customer education or instructions on how to use the appliance.
- Any content loss due to product failure.
- Removal or installation.

Nor do the above warranties cover failure of this product or its components due to:

1. Transportation or subsequent damages.
2. Use commercially or use other than normal household or small office.
3. Improper installation, misuse, abuse, accident or alteration, use on wiring not conforming to electrical codes, low or high voltages, failure to provide necessary maintenance, or other unreasonable use.

## Parts or Service

### Not Supplied or Designated by Marvel

The above warranties also do not apply if:

The original bill of sale, deliver date or serial number cannot be verified.

Defective parts are not returned for inspection if so requested by Marvel.

The refrigeration equipment is not in the possession of the original end use purchaser.

The warranties set forth herein are the only warranties extended by Marvel Industries. Any implied warranties, including the implied warranty of merchantability, are limited to the duration of these express warranties. In no event shall Marvel Industries be liable for any consequential or incidental damages or expenses resulting from breach of these or any other warranties, whether express or implied.

Some states do not allow the exclusion or limitation of consequential damages or a limitation on how long an implied warranty lasts, so the above exclusion or limitation may not apply to you. This warranty gives you specific legal rights and you may have other rights that may vary from state to state.

No person, firm, or corporation is authorized to make any other warranty or assume any other obligation for Marvel Industries. These warranties apply only to products used in any of the fifty states of the United States and the District of Columbia.

To obtain performance of this warranty, report any defects to:

**Marvel Industries**  
**P.O. Box 997**  
**Richmond, Indiana 47375-0997**  
**Phone: 765-962-2521**

## NOTES

---



[WWW.MARVELINDUSTRIES.COM](http://WWW.MARVELINDUSTRIES.COM)

**Phone: (765) 962-2521 Fax: (765) 962-2493**

**MARVEL**  
I N D U S T R I E S

An AGA Company  
233 Industrial Parkway  
P.O. Box 997  
Richmond, IN 47375-0997