



LUMINARY MICRO®

Stellaris® LM3S6965
Evaluation Board

USER'S MANUAL

Legal Disclaimers and Trademark Information

INFORMATION IN THIS DOCUMENT IS PROVIDED IN CONNECTION WITH LUMINARY MICRO PRODUCTS. NO LICENSE, EXPRESS OR IMPLIED, BY ESTOPPEL OR OTHERWISE, TO ANY INTELLECTUAL PROPERTY RIGHTS IS GRANTED BY THIS DOCUMENT. EXCEPT AS PROVIDED IN LUMINARY MICRO'S TERMS AND CONDITIONS OF SALE FOR SUCH PRODUCTS, LUMINARY MICRO ASSUMES NO LIABILITY WHATSOEVER, AND LUMINARY MICRO DISCLAIMS ANY EXPRESS OR IMPLIED WARRANTY, RELATING TO SALE AND/OR USE OF LUMINARY MICRO'S PRODUCTS INCLUDING LIABILITY OR WARRANTIES RELATING TO FITNESS FOR A PARTICULAR PURPOSE, MERCHANTABILITY, OR INFRINGEMENT OF ANY PATENT, COPYRIGHT OR OTHER INTELLECTUAL PROPERTY RIGHT. LUMINARY MICRO'S PRODUCTS ARE NOT INTENDED FOR USE IN MEDICAL, LIFE SAVING, OR LIFE-SUSTAINING APPLICATIONS.

Luminary Micro may make changes to specifications and product descriptions at any time, without notice. Contact your local Luminary Micro sales office or your distributor to obtain the latest specifications before placing your product order.

Designers must not rely on the absence or characteristics of any features or instructions marked "reserved" or "undefined." Luminary Micro reserves these for future definition and shall have no responsibility whatsoever for conflicts or incompatibilities arising from future changes to them.

Copyright © 2007–2008 Luminary Micro, Inc. All rights reserved. Stellaris, Luminary Micro, and the Luminary Micro logo are registered trademarks of Luminary Micro, Inc. or its subsidiaries in the United States and other countries. ARM and Thumb are registered trademarks, and Cortex is a trademark of ARM Limited. Other names and brands may be claimed as the property of others.

Luminary Micro, Inc.
108 Wild Basin, Suite 350
Austin, TX 78746
Main: +1-512-279-8800
Fax: +1-512-279-8879
<http://www.luminarymicro.com>



LUMINARY MICRO



Table of Contents

Chapter 1: Stellaris® LM3S6965 Evaluation Board	7
Features	8
Block Diagram	8
Evaluation Kit Contents	9
Evaluation Board Specifications	9
Features of the LM3S6965 Microcontroller.....	9
Chapter 2: Hardware Description	11
LM3S6965 Microcontroller	11
Device Overview	11
Ethernet	11
Clocking	11
Reset.....	11
Power Supplies	12
Debugging.....	12
USB Device Controller Functions	13
Device Overview	13
USB to JTAG/SWD	13
Virtual COM Port.....	13
Serial Wire Out.....	13
Organic LED Display	13
Features	13
Control Interface	14
Power Supply.....	14
Design Guidelines.....	14
Further Reference.....	14
Other Peripherals.....	14
Speaker.....	14
MicroSD Card Slot	14
Push Switches	14
User LED	15
Bypassing Peripherals	15
Interfacing to the EVB.....	15
Using the In-Circuit Debugger Interface	16
Appendix A: Schematics	17
Appendix B: Connection Details	23
Component Locations	23
Evaluation Board Dimensions.....	24
I/O Breakout Pads	24
Recommended Connectors	25
ARM Target Pinout	26
References	26
Appendix C: Contact Information	29

List of Figures

Figure 1-1. Stellaris LM3S6965 Evaluation Board Layout	7
Figure 1-2. LM3S6965 Evaluation Board Block Diagram	8
Figure 2-1. ICD Interface Mode	16
Figure A-1. LM3S6965 Microcontroller (sheet 1 of 3)	18
Figure A-2. LM3S6965 Microcontroller (sheet 2 of 3)	19
Figure A-3. LM3S6965 Microcontroller (sheet 3 of 3)	20
Figure A-4. PLD schematic	21
Figure B-1. Component Locations	23
Figure B-2. Evaluation Board Dimensions	24

List of Tables

Table 2-1. Stellaris LM3S6965 Evaluation Board Hardware Debugging Configurations.....	12
Table 2-2. Isolating On-Board Hardware.....	15
Table B-1. I/O Breakout Pads.....	25
Table B-2. Recommended Connectors.....	25
Table B-3. 20-Pin JTAG/SWD Configuration.....	26



Stellaris® LM3S6965 Evaluation Board

The Stellaris® LM3S6965 Evaluation Board is a compact and versatile evaluation platform for the Stellaris LM3S6965 ARM® Cortex™-M3-based microcontroller. The evaluation kit uses the LM3S6965 microcontroller's fully integrated 10/100 Ethernet controller to demonstrate an embedded web server.

You can use the board either as an evaluation platform or as a low-cost in-circuit debug interface (ICDI). In debug interface mode, the on-board microcontroller is bypassed, allowing programming or debugging of an external target. The kit is also compatible with high-performance external JTAG debuggers.

This evaluation kit enables quick evaluation, prototype development, and creation of application-specific designs for Ethernet networks. The kit also includes extensive source-code examples, allowing you to start building C code applications quickly.

Figure 1-1. Stellaris LM3S6965 Evaluation Board Layout

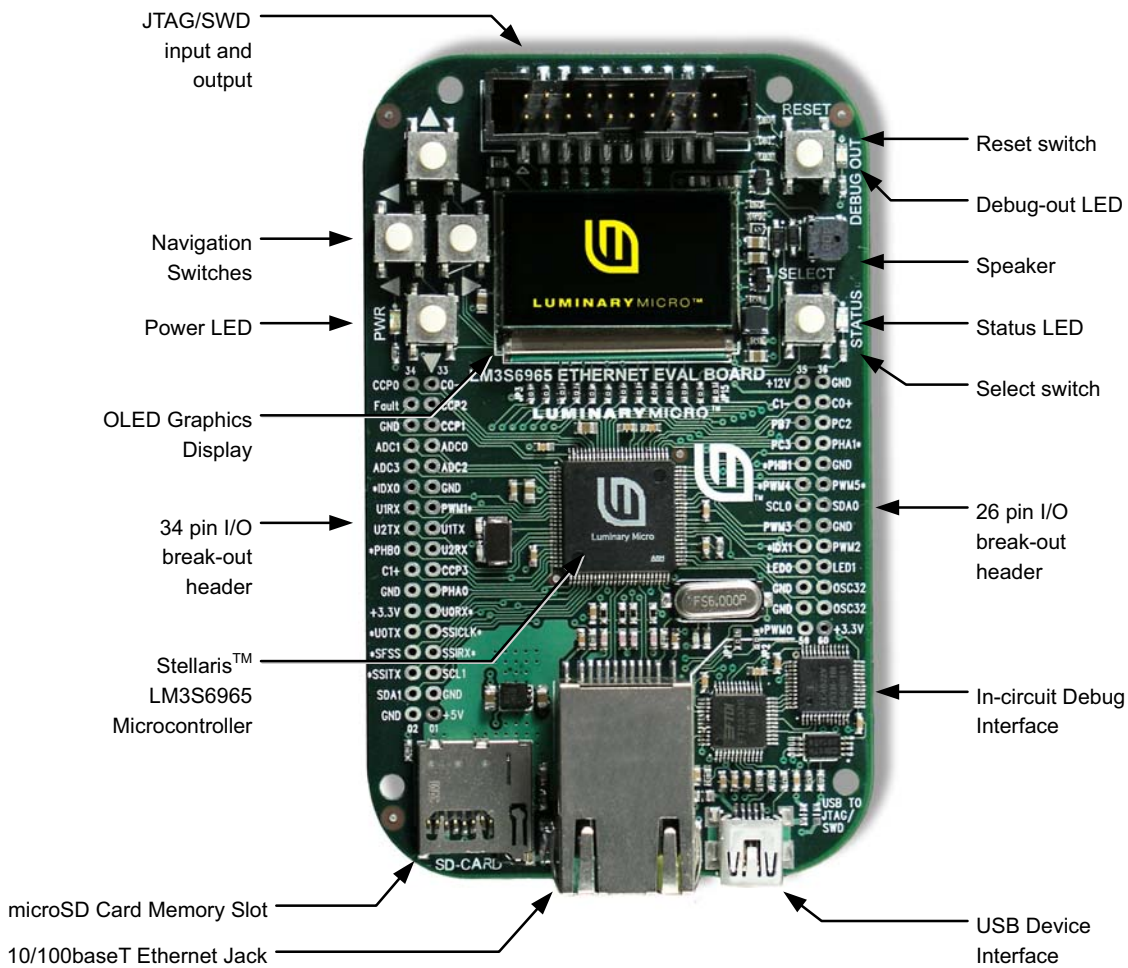

Features

The Stellaris LM3S6965 Evaluation Board includes the following features:

- Stellaris LM3S6965 microcontroller with fully-integrated 10/100 embedded Ethernet controller
- Simple setup; USB cable provides serial communication, debugging, and power
- OLED graphics display with 128 x 96 pixel resolution
- User LED, navigation switches, and select pushbuttons
- Magnetic speaker
- LM3S6965 I/O available on labeled break-out pads
- Standard ARM® 20-pin JTAG debug connector with input and output modes
- USB interface for debugging and power supply
- MicroSD card slot

Block Diagram

Figure 1-2. LM3S6965 Evaluation Board Block Diagram

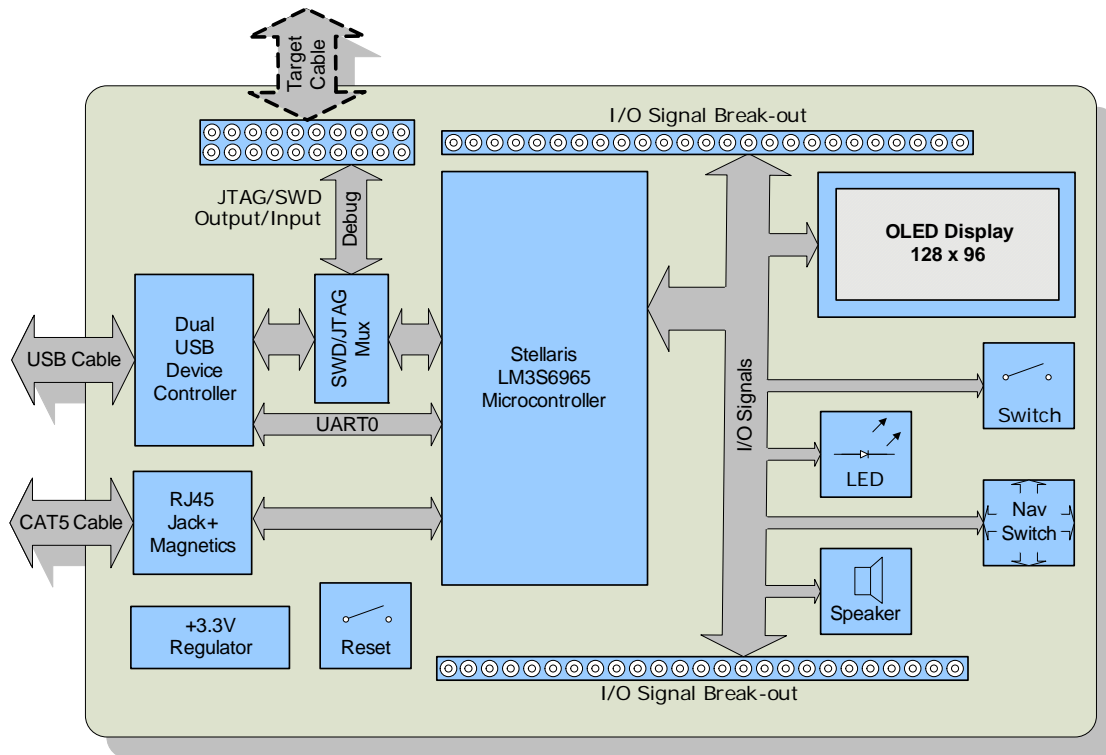

Evaluation Kit Contents

The evaluation kit contains everything needed to develop and run applications for Stellaris microcontrollers including:

- LM3S6965 Evaluation Board (EVB)
- USB cable
- 20-pin JTAG/SWD target cable
- CD containing:
 - A supported, evaluation version of one of the following:
 - Keil™ RealView® Microcontroller Development Kit (MDK-ARM)
 - IAR Embedded Workbench® development tools
 - Code Sourcery GCC development tools
 - Code Red Technologies development tools
 - Complete documentation
 - Quickstart guide
 - Quickstart source code
 - Stellaris® Firmware Development Package with example source code

Evaluation Board Specifications

- Board supply voltage: 4.37–5.25 Vdc from USB connector
- Board supply current: 250 mA typ (fully active, CPU at 50 MHz)
- Break-out power output: 3.3 Vdc (60 mA max), 15 Vdc (15 mA max)
- Dimensions: 4.0" x 2.45" x 0.7" (LxWxH)
- RoHS status: Compliant

Features of the LM3S6965 Microcontroller

- 32-bit RISC performance using ARM® Cortex™-M3 v7M architecture
 - 50-MHz operation
 - Hardware-division and single-cycle-multiplication
 - Integrated Nested Vectored Interrupt Controller (NVIC)
 - 42 interrupt channels with eight priority levels
- 256 KB single-cycle Flash
- 64 KB single-cycle SRAM
- Four general-purpose 32-bit timers
- Integrated Ethernet MAC and PHY
- Three fully programmable 16C550-type UARTs
- Four 10-bit channels (inputs) when used as single-ended inputs
- Two independent integrated analog comparators

- Two I²C modules
- Three PWM generator blocks
 - One 16-bit counter
 - Two comparators
 - Produces two independent PWM signals
 - One dead-band generator
- Two QEI modules with position integrator for tracking encoder position
- 0 to 42 GPIOs, depending on user configuration
- On-chip low drop-out (LDO) voltage regulator



Hardware Description

In addition to a microcontroller, the Stellaris LM3S6965 evaluation board includes a range of useful peripherals and an integrated ICDI. This chapter describes how these peripherals operate and interface to the MCU.

LM3S6965 Microcontroller

Device Overview

The heart of the EVB is a Stellaris LM3S6965 ARM Cortex-M3-based microcontroller. The LM3S6965 offers 256 KB Flash memory, 50-MHz operation, an Ethernet controller, and a wide range of peripherals. Refer to the LM3S6965 data sheet (order number DS-LM3S6965) for complete device details.

The LM3S6965 microcontroller is factory programmed with a quickstart demo program. The quickstart program resides in the LM3S6965 on-chip Flash memory and runs each time power is applied, unless the quickstart has been replaced with a user program.

Ethernet

A key feature of the LM3S6965 microcontroller is its fully integrated Ethernet controller. Only a RJ45 jack with integrated magnetics and a few passive components are needed to complete the 10/100baseT interface. The RJ45 jack incorporates LEDs that indicate traffic and link status. These are automatically managed by on-chip microcontroller hardware. Alternatively, the LEDs can be software controlled by configuring those pins as general-purpose outputs.

The LM3S6965 supports automatic MDI/MDI-X so the EVB can connect directly to a network or to another Ethernet device without requiring a cross-over cable.

Clocking

The LM3S6965 microcontroller has four on-chip oscillators, three are implemented on the EVB. A 8.0-MHz crystal completes the LM3S6965's main internal clock circuit. An internal PLL, configured in software, multiplies this clock to 50-MHz for core and peripheral timing.

A small, 25-MHz crystal is used by the LM3S6965 microcontroller for Ethernet physical layer timing and is independent of the main oscillator.

Reset

The LM3S6965 microcontroller shares its external reset input with the OLED display. In the EVB, reset sources are gated through the CPLD, though in a typical application a simple wired-OR arrangement is sufficient.

Reset is asserted (active low) under any one of three conditions:

- Power-on reset
- Reset push switch SW1 held down
- Internal debug mode—By the USB device controller (U4 FT2232) when instructed by debugger

Power Supplies

The LM3S6965 is powered from a +3.3-V supply. A low drop-out (LDO) regulator regulates +5-V power from the USB cable to +3.3-V. +3.3-V power is available for powering external circuits.

A +15-V rail is available when the OLED display is active. The speaker and OLED display boost-converter operate directly from the +5-V rail.

Debugging

Stellaris microcontrollers support programming and debugging using either JTAG or SWD. JTAG uses the signals TCK, TMS, TDI, and TDO. SWD requires fewer signals (SWCLK, SWDIO, and, optionally, SWO, for trace). The debugger determines which debug protocol is used.

Debugging Modes

The LM3S6965 evaluation board supports a range of hardware debugging configurations. Table 2-1 summarizes these configurations.

Table 2-1. Stellaris LM3S6965 Evaluation Board Hardware Debugging Configurations

Mode	Debug Function	Use	Selected by
1	Internal ICDI	Debug on-board LM3S6965 microcontroller over USB interface.	Default mode
2	ICDI out to JTAG/SWD header	The EVB is used as a USB to SWD/JTAG interface to an external target.	Connecting to an external target and starting debug software. The red Debug Out LED will be ON.
3	In from JTAG/SWD header	For users who prefer an external debug interface (ULINK, JLINK, etc.) with the EVB.	Connecting an external debugger to the JTAG/SWD header.

Modes 2 and 3 automatically detect the presence of an external debug cable. When the debugger software is connected to the EVB's USB controller, the EVB automatically selects Mode 2 and illuminates the red Debug Out LED.

Debug In Considerations

Debug Mode 3 supports evaluation board debugging using an external debug interface. Mode 3 is automatically selected when a device such as a Segger J-Link or Keil ULINK is connected.

Boards marked Revision D or later automatically configure pin 1 to be a 3.3-V reference, if an external debugger is connected. To determine the revision of your board, locate the product number on the bottom of the board; for example, EK-LM3S6965-D. The last character of the product number identifies the board revision.

A configuration or board-level change may be necessary when using an external debug interface with revisions A through C of this evaluation board. Because the evaluation board supports both debug out and debug in modes, pin 1 of the 20-pin JTAG/SWD header is, by default, not connected to +3.3 V. Consequently, devices requiring a voltage on pin 1 to power their line buffers may not work.

Two solutions exist. Some debugger interfaces (such as ULINK) have an internal power jumper that, in this case, should be set to internal +3.3-V power. Refer to debugger interface

documentation for full details. However, if your debugger interface does not have a selectable power source, it may be necessary to install a 0-Ω resistor on the evaluation board to route power to pin 1. Refer to the schematics and board drawing in the appendix of this manual for the location of this resistor.

USB Device Controller Functions

Device Overview

An FT2232 device from Future Technology Devices International Ltd manages USB-to-serial conversion. The FT2232 is factory configured by Luminary Micro to implement a JTAG/SWD port (synchronous serial) on channel A and a Virtual COM Port (VCP) on channel B. This feature allows two simultaneous communications links between the host computer and the target device using a single USB cable. Separate Windows drivers for each function are provided on the Documentation and Software CD.

A small serial EEPROM holds the FT2232 configuration data. The EEPROM is not accessible by the LM3S6965 microcontroller.

For full details on FT2232 operation, go to www.ftdichip.com.

USB to JTAG/SWD

The FT2232 USB device performs JTAG/SWD serial operations under the control of the debugger. A CPLD (U2) multiplexes SWD and JTAG functions and, when working in SWD mode, provides direction control for the bidirectional data line.

Virtual COM Port

The Virtual COM Port (VCP) allows Windows applications (such as HyperTerminal) to communicate with `UART0` on the LM3S6965 over USB. Once the FT2232 VCP driver is installed, Windows assigns a COM port number to the VCP channel.

Serial Wire Out

The evaluation board supports the Cortex-M3 serial-wire output (SWO) trace capabilities. Under debugger control, the CPLD can route the SWO datastream to the virtual communication port (VCP) transmit channel. The debugger can then decode and interpret the trace information received from the VCP. The normal VCP connection to `UART0` is interrupted when using SWO. Not all debuggers support SWO. Refer to the Stellaris LM3S3748 data sheet for additional information on the trace port interface unit (TPIU).

Organic LED Display

The EVB features an organic LED (OLED) graphics display with 128 x 96 pixel resolution. OLED is a new technology that offers many advantages over LCD display technology.

Features

- RiT P14201 series display
- 128 columns by 96 rows
- High-contrast (typ. 500:1)
- Excellent brightness (120 cd/m²)
- Fast 10 us response

Control Interface

The OLED display has a built-in controller IC with synchronous serial and parallel interfaces. Synchronous serial (SSI) is used on the EVB as it requires fewer microcontroller pins. Data cannot be read from the OLED controller; only one data line is necessary. Note that the SSI port is shared with the microSD card slot. The Stellaris® Firmware Development Package (included on the Documentation and Software CD) contains complete drivers with source-code for the OLED display.

Power Supply

A +15-V supply is needed to bias the OLED display. A FAN5331 device from Fairchild combines with a few external components to complete a boost converter. When the OLED display is operating, a small amount of power can be drawn from the +15-V rail to power other devices.

Design Guidelines

The OLED display has a lifetime of about 13,000 hours. It is also prone to degradation due to burn-in, similar to CRT and plasma displays. The quickstart application includes both a screen saver and a power-down mode to extend display life. These factors should be considered when developing EVB applications that use the OLED display.

When using the EVB as an in-circuit debug interface (ICDI), the OLED display is held in reset to reduce power consumption and eliminate display wear-out.

Further Reference

For additional information on the RiT OLED display, visit www.ritekdisplay.com.

Other Peripherals

Speaker

A small, magnetic audio transducer connects through a MOSFET to PD1/PWM1, allowing a range of options for generating simple and complex tones. Use of the +5-V rail reduces switching noise on the +3.3-V rail.

MicroSD Card Slot

Removable Flash cards are an ideal media for storing data such as web page content. The source code on the CD includes example code for reading data from standard FAT formatted SD cards. All data and control transactions use the SD card's SPI mode. Note that the SD card specification does not require that a card supports the SPI mode, but most cards do so in practice. Cards from several vendors have been used with the EVB.

MicroSD cards are very small and require careful handling. the SD card slot on the EVB is a push-push type (push to insert; push again to eject).

Note: To avoid damage, *remove power before inserting or removing cards.* The EVB does not implement SD card power control.

Push Switches

The EVB has five general-purpose input switches. Four are arranged in a navigation-style configuration. The fifth functions as a Select switch.

User LED

A user LED (LED3) is provided for general use. The LED is connected to PC5/CCP1, allowing the option of either GPIO or PWM control (brightness control). Refer to the Quickstart Application source code for an example of PWM control.

Bypassing Peripherals

Excluding Ethernet, the EVB's on-board peripheral circuits require 16 GPIO lines. Two additional GPIO lines are assigned to Ethernet LEDs. This leaves 20 GPIO lines and 4 ADC channels immediately available for connection to external circuits. If an application requires more GPIO lines, the on-board hardware can be disconnected. The EVB is populated with 16 jumper links, which can be cut with a knife to isolate on-board hardware. The process can be reversed by installing 0603- 0-ohm chip resistors.

Important: The quickstart application will not run if one or more jumpers are removed.

Table 2-2. Isolating On-Board Hardware

MCU Pin	EVB Function	To Isolate, Remove...
Pin 26 PA0/U0RX	Virtual COM port receive	JP1
Pin 27 PA1/U0TX	Virtual COM port transmit	JP2
Pin 10 PD0/IDX0	SD card chip select	JP3
Pin 11 PD1/PWM1	Sound	JP4
Pin 30 PA4/SSI0RX	SD card data out	JP5
Pin 31 PA5/SSI0TX	SD card and OLED display data in	JP6
Pin 28 PA2/SSI0CLK	SD card and OLED display clock	JP7
Pin 22 PC7/PHB0	OLED display data/control select	JP8
Pin 29 PA3/SSI0FSS	OLED display chip select	JP9
Pin 73 PE1/PWM5	Down switch	JP10
Pin 74 PE2/PHB1	Left switch	JP11
Pin 72 PE0/PWM4	Up switch	JP12
Pin 75 PE3/PHA1	Right switch	JP13
Pin 61 PF1/IDX1	Select switch	JP14
Pin 47 PF0/PWM0	User LED	JP15
Pin 23 PC6/CCP3	Enable +15 V	JP16

Interfacing to the EVB

An array of accessible I/O signals makes it easy to interface the EVB to external circuits. All LM3S6965 I/O lines (except those with both JTAG and SWD functions) are brought out to 0.1" pitch pads. For quick reference, silk-screened labels on the PCB show primary pin functions.

Table B-1 on page 25 has a complete list of I/O signals as well as recommended connectors.

Most LM3S6965 I/O signals are +5-V tolerant. Refer to the LM3S6965 data sheet for detailed electrical specifications.

Using the In-Circuit Debugger Interface

The Stellaris LM3S6965 Evaluation Kit can operate as an In-Circuit Debugger Interface (ICDI). ICDI acts as a USB to the JTAG/SWD adaptor, allowing debugging of any external target board that uses a Stellaris microcontroller. See “Debugging Modes” on page 12 for a description of how to enter Debug Out mode.

Figure 2-1. ICD Interface Mode

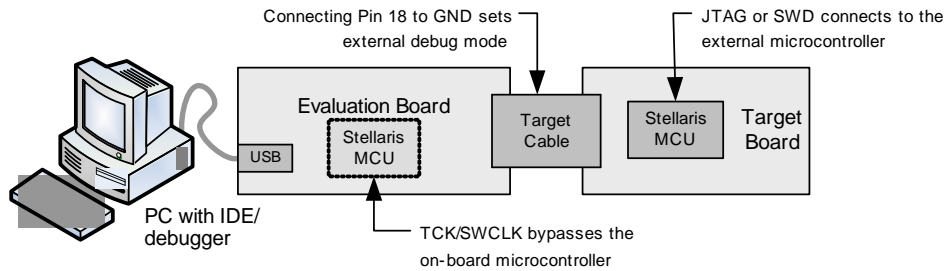

The debug interface operates in either Serial-Wire Debug (SWD) or full JTAG mode, depending on the configuration in the debugger IDE.

The IDE/debugger does not distinguish between the on-EVB Stellaris microcontroller and an external Stellaris microcontroller. The only requirement is that the correct Stellaris device is selected in the project configuration.



Schematics

Schematics for the Stellaris LM3S6965 Evaluation Board follow.

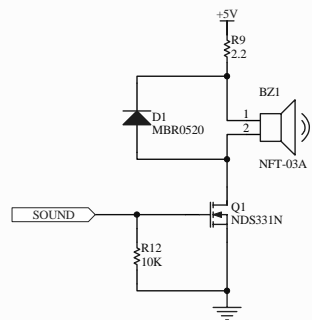

Speaker Circuit

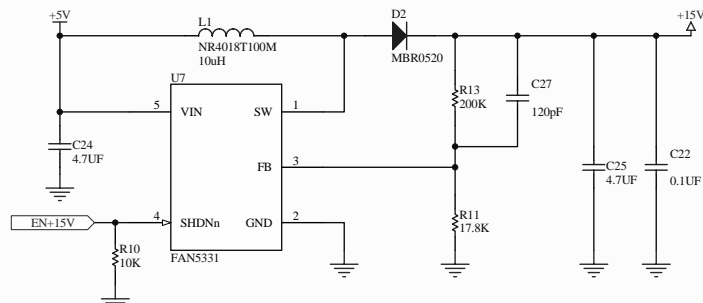

+15V 50mA Power Supply for OLED Display

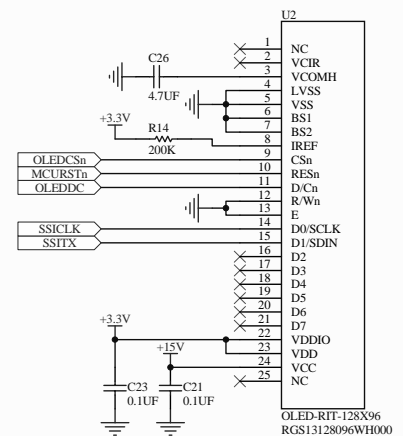

128x96 OLED Graphics Display

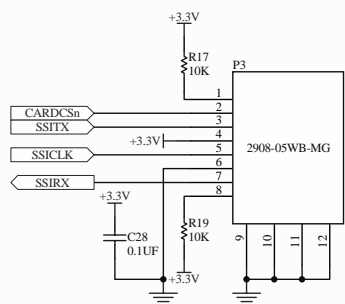

microSD Card Slot

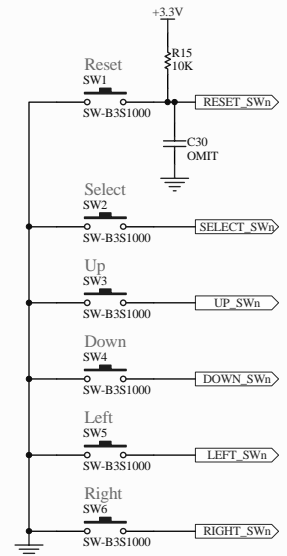

User Switches

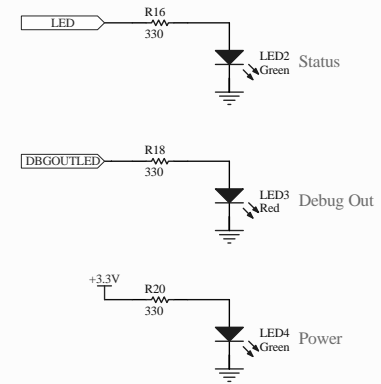

Status LEDs

Drawing Title: Ethernet Evaluation Board			
Page Title: OLED Display, Switches and Audio			
Size B	Document Number: 2		
Date: 3/26/2008	Sheet 2 of 3	Rev D	

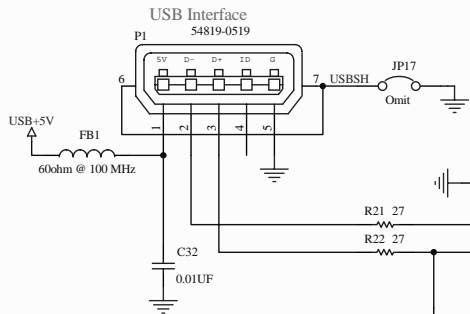

USB Device Controller

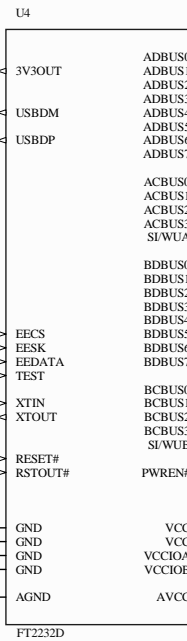

Channel A : JTAG / SW Debug
Channel B : Virtual Com Port

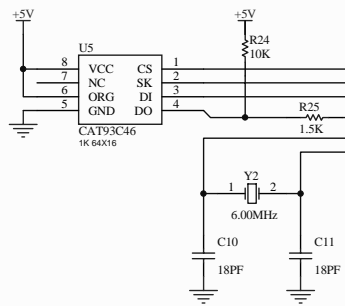

USB +5V to +3.3V 500mA Power Supply

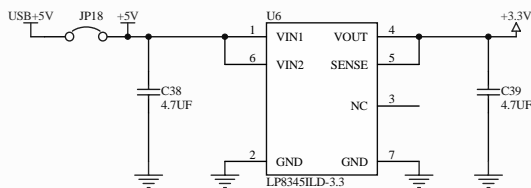

Debug Interface Logic

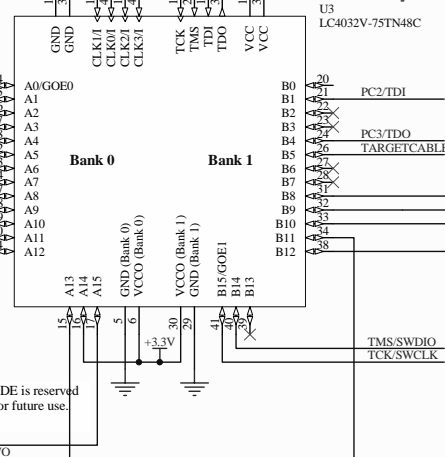
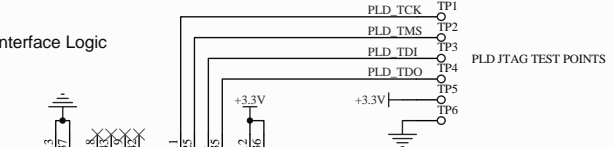

JTAG/SWD Interface Input/Output

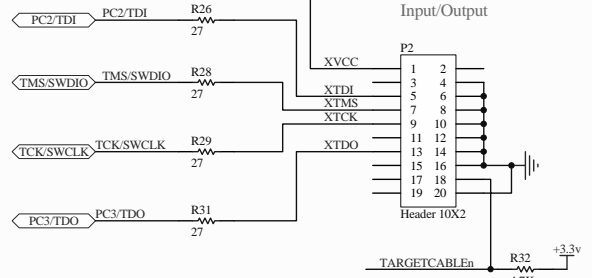

LUMINARY MICRO

Drawing Title: Ethernet Evaluation Board
Page Title: USB, Debugger Interfaces and Power
Size B Document Number: 3
Date: 3/26/2008 Sheet 3 of 3 Rev D

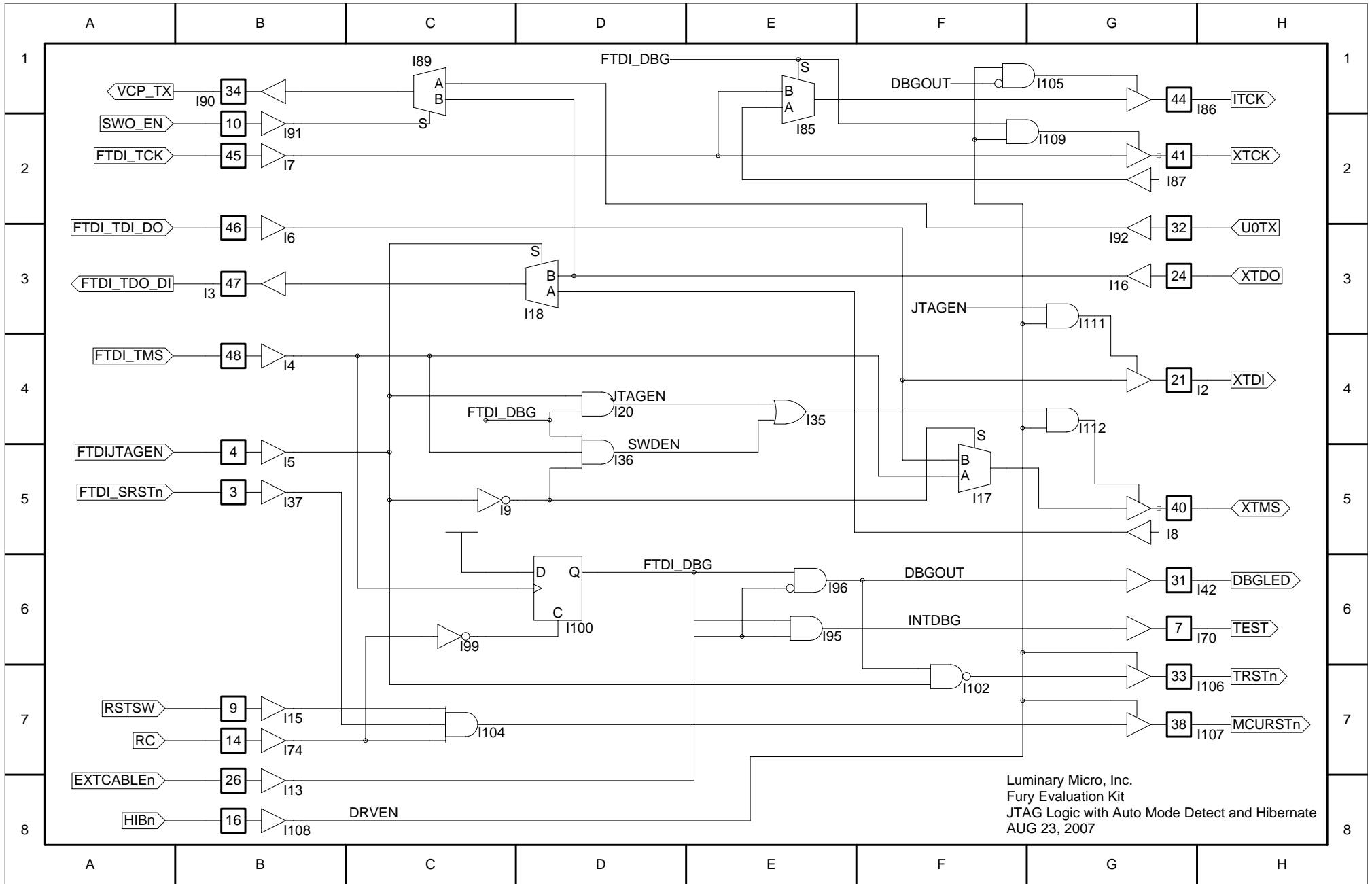



Connection Details

This appendix contains the following sections:

- Component Locations
- Evaluation Board Dimensions
- I/O Breakout Pads
- ARM Target Pinout
- References

Component Locations

Figure B-1. Component Locations

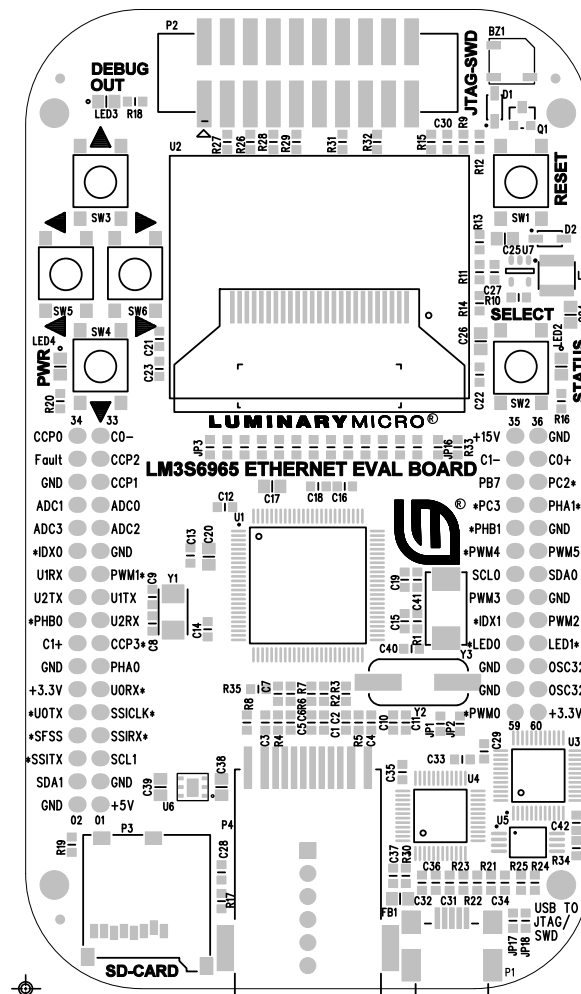

Evaluation Board Dimensions

Figure B-2. Evaluation Board Dimensions

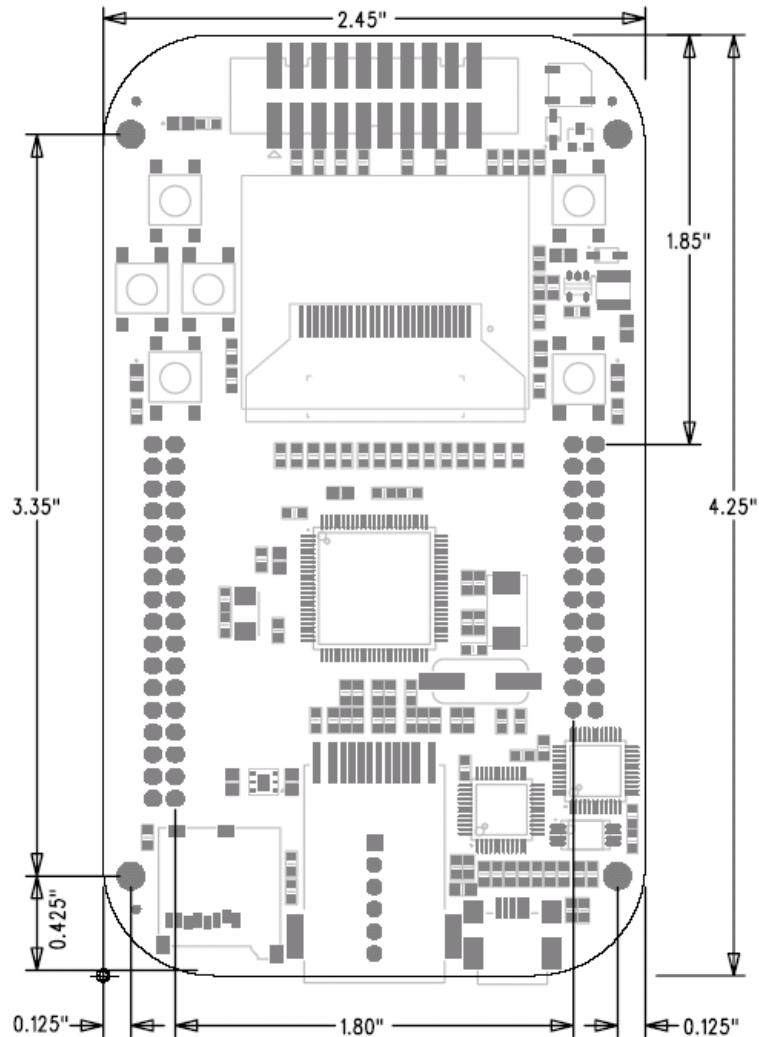

I/O Breakout Pads

The LM3S6965 EVB has 44 I/O pads, 14 power pads, and 2 crystal connections, for a total of 60 pads. Connection can be made by soldering wires directly to these pads, or by using 0.1" pitch headers and sockets.

Note: In Table B-2, an asterisk (*) by a signal name (also on the EVB PCB) indicates the signal is normally used for on-board functions. Normally, you should cut the associated jumper (JP1-15) before using an assigned signal for external interfacing.

Table B-1. I/O Breakout Pads

Description	Pad No.	Pad No.	Description	Description	Pad No.	Pad No.	Description
PD4/CCP0	34	33	PB4/C0-	+12 V	60	59	GND
PD6/FAULT	32	31	PD5/CCP2	PB5/C1-	58	57	PB6/C0+
GND	30	29	PD7/CCP1	PB7/TRST	56	55	PC2/TDI*
ADC1	28	27	ADC0	PC3/TDO*	54	53	PE3/PHA1*
ADC3	26	25	ADC2	PE2/PHB1	52	51	GND
IDX0*	24	23	GND	PE0/PWM4	50	49	PE1/PWM5*
PD2/U1RX	22	21	PD1/PWM1	PB2/SCL0	48	47	PB3/SDA0
PG2/U2TX	20	19	PD3/U1TTX	PB1/PWM3	46	45	GND
PC7/PHB0*	18	17	PG0/U2RX	PF1/IDX1	44	43	PB0/PWM2
PC5/C1+	16	15	PC6/CCP3*	PF3/LED0	42	41	PF2/LED1
GND	14	13	PC4/PHA0	GND	40	39	OSC32
+3.3 V	12	11	PA0/U0RX*	GND	38	37	OSC32
PA1/U0TX*	10	9	PA2/SSICLK*	PF0/PWM0	36	35	+3.3 V
PA3/SFSS*	8	7	PA4/SSIRX*				
PA5/SSITX*	6	5	PA6/SCL1				
PA7/SDA1	4	3	GND				
GND	2	1	+5 V				

Recommended Connectors

Connection can be made by soldering wires directly to pads or using 0.1" pitch headers and sockets.

Table B-2. Recommended Connectors

Pins 1-34 (2 x 17 way)	PCB Socket	Sullins PPPC172LFBN-RC	Digikey S7120-ND
	Cable Socket	3M 89134-0101	Digikey MKC34A-ND
	Pin Header	Sullins PEC17DAAN	Digikey S2012E-17-ND
Pins 35-06 (2 x 13 way)	PCB Socket	Sullins PPPC132LFBN-RC	Digikey S7116-ND
	Cable Socket	3M 89126-0101	Digikey MKC26A-ND
	Pin Header	Sullins PEC13DAAN	Digikey S2012-13-ND

ARM Target Pinout

In ICDI input and output mode, the Stellaris LM3S6965 Evaluation Kit supports ARM's standard 20-pin JTAG/SWD configuration. The same pin configuration can be used for debugging over Serial Wire Debug (SWD) and JTAG interfaces. The debugger software, running on the PC, determines which interface protocol is used.

The Stellaris target board should have a 2x10 0.1" pin header with signals as indicated in Table B-3. This applies to both an external Stellaris MCU target (Debug output mode) and to external JTAG/SWD debuggers (Debug input mode).

Table B-3. 20-Pin JTAG/SWD Configuration

Function	Pin	Pin	Function
VCC	1	2	nc
nc	3	4	GND
TDI	5	6	GND
TMS	7	8	GND
TCK	9	10	GND
NC	11	12	GND
TDO	13	14	GND
nc	15	16	GND
nc	17	18	GND
nc	19	20	GND

ICDI does not control \overline{RST} (device reset) or \overline{TRST} (test reset) signals. Both reset functions are implemented as commands over JTAG/SWD, so these signals are not necessary.

It is recommended that connections be made to all GND pins; however, both targets and external debug interfaces must connect pin 18 and at least one other GND pin to GND.

References

In addition to this document, the following references are included on the Stellaris Family Development Kit documentation CD-ROM and are also available for download at www.luminarymicro.com:

- *Stellaris LM3S6965 Evaluation Kit Quickstart Guide* for appropriate tool kit (see "Evaluation Kit Contents," on page 9)
- *Stellaris LM3S6965 Read Me First* for the ENET Evaluation Kit
- Stellaris Family Peripheral Driver Library
- *Stellaris Family Peripheral Driver Library User's Manual*, publication PDL-LM3S6965
- *Stellaris LM3S6965 Data Sheet*, publication DS-LM3S6965

Additional references include:

- Information on development tool being used:
 - RealView MDK web site, www.keil.com/arm/rvmdkkit.asp
 - IAR Embedded Workbench web site, www.iar.com
 - Code Sourcery GCC development tools web site, www.codesourcery.com/gnu_toolchains/arm
 - Code Red Technologies development tools web site, www.code-red-tech.com



Contact Information

Company Information

Luminary Micro, Inc. designs, markets, and sells ARM Cortex-M3-based microcontrollers (MCUs). Austin, Texas-based Luminary Micro is the lead partner for the Cortex-M3 processor, delivering the world's first silicon implementation of the Cortex-M3 processor. Luminary Micro's introduction of the Stellaris® family of products provides 32-bit performance for the same price as current 8- and 16-bit microcontroller designs. With entry-level pricing at \$1.00 for an ARM technology-based MCU, Luminary Micro's Stellaris product line allows for standardization that eliminates future architectural upgrades or software tool changes.

Luminary Micro, Inc.
108 Wild Basin, Suite 350
Austin, TX 78746
Main: +1-512-279-8800
Fax: +1-512-279-8879
<http://www.luminarymicro.com>

Support Information

For support on Luminary Micro products, contact:

support@luminarymicro.com
+1-512-279-8800, ext. 3
