

martinarchitectural

Exterior 600



user manual

Martin

Measurements are in millimeters

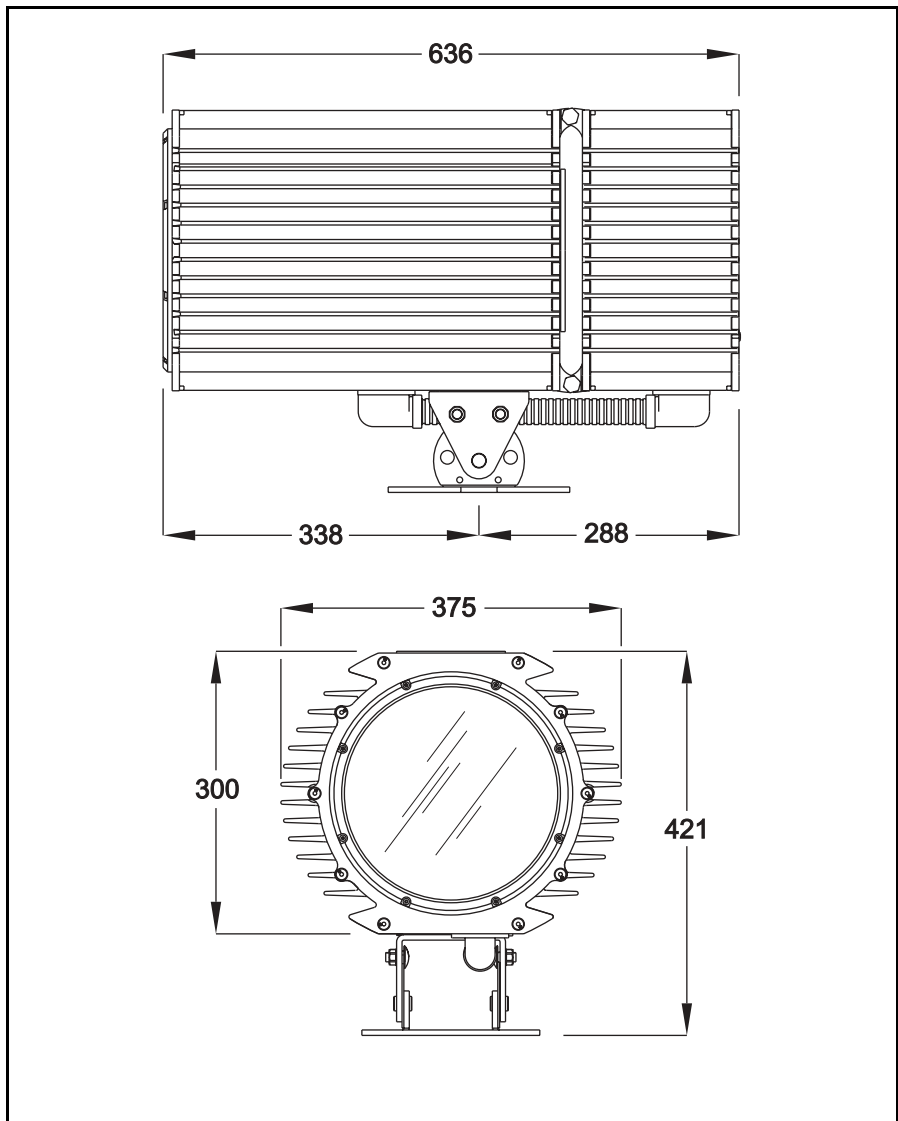

© 1999-2004 Martin Professional A/S, Denmark.

All rights reserved. No part of this manual may be reproduced, in any form or by any means, without permission in writing from Martin Professional A/S, Denmark.

Printed in Denmark.

P/N 35000020, Rev H

SECTION 1. GETTING STARTED.....	7
INTRODUCTION	8
Software note	9
Safety information	9
INSTALLATION	11
Unpacking	11
Lamp Installation	11
Fixture installation	11
AC POWER	14
Power configuration	14
Connection to the mains supply	14
DATA LINK	19
Cable and junctions	19
Adaptors	20
Building a data link	21
FIXTURE SETTINGS	22
Defining fixture settings using MUM	24
GENERAL OPERATION	27
Lamp operation	27
Cold weather operation	27
The LEDs and fixture operating status	27
Fixture control methods	28
Color matching Exterior 200s and 600s	29
SECTION 2. STAND-ALONE OPERATION	31
STAND-ALONE PROGRAMMING OVERVIEW	32
About scene timing	33
Synchronizing scene changes for multiple Exterior 600s	33
Programming methods	34
PROGRAMMING FROM A PC USING MUM	35
Getting started	35
Stand-Alone Settings	36
Programming effects in scenes	38
Programming the same stand-alone show on multiple fixtures	40
STAND-ALONE SHOW PLAYBACK	41
Starting show playback automatically at fixture power-on	41

Scene execution using the optional MC-X	41
DMX controller override during stand-alone show playback	42
SYNCHRONOUS TRIGGERING DURING STAND-ALONE OPERATION	43
SECTION 3. DMX CONTROL.....	45
PREPARING A FIXTURE FOR DMX CONTROL.	46
DMX address	46
DMX lamp off option.	47
DMX reset option	47
DMX mode	47
DMX CONTROLLER OPERATION.	49
Effect operation	50
Lamp	51
Color.	51
Dimmer.	52
Shutter	52
Zoom	52
Beam shaper and frost.	53
DMX PROTOCOL.	54
SECTION 4. SERVICE AND TROUBLESHOOTING	57
SEAL MAINTENANCE	58
Gaskets	58
Cable glands	59
CLEANING	60
Cleaning lenses	60
Cleaning the housing	60
FIRMWARE UPDATES.	61
Normal updates (DMX/Auto mode upload)	61
When the normal method fails (boot mode upload)	62
When the fixture is not responding (boot mode & boot sector upload)	62
LAMP MAINTENANCE	64
Compatible lamps	64
Maximum lamp usage	64
Installing the lamp	66
MAINTAINING THE ELECTRICAL SYSTEM	69
Replacing fuses	69
Changing the power settings	71

Installing a battery on the PCB. 73

TROUBLESHOOTING. 75

SECTION 5. REFERENCE 77

PCB LAYOUT 78

SPECIFICATIONS 79

SECTION 1. GETTING STARTED

This section contains the following chapters:

- “Introduction” on page 8
- “Installation” on page 11
- “AC power” on page 14
- “Data link” on page 19
- “Fixture settings” on page 22
- “General operation” on page 27

Introduction

Thank you for selecting the Martin Exterior 600. This automated luminaire combines a range of architectural lighting effects with extremely bright output in an attractive aluminum housing designed for permanent outdoor installation. It features seamless cyan, magenta, yellow (CMY) color mixing and full-range continuous dimming. The fixture may be operated with DMX controllers or in stand-alone mode with programmable start and stop times or light levels.

An Exterior 600 running a pre-programmed show can perform synchronized scene changes with up to 31 other Martin fixtures of the following types:

- Exterior 200
- Exterior 600
- Exterior 600 Compact
- FiberSource CMY150
- Imager series
- Alien 02 series
- MiniMAC Maestro

Exterior 600 range

The Exterior 600 is available in 20 models, spanning five optical configurations, with the following beam angles:

- 12°
- 18-25°
- 22-38°
- 65°
- 100°

(An optional beam shaper lens (20° x 77°) is available for Exterior 600, 12° models. This is in addition to the built-in beam shaper effect that is available to DMX-controlled Exterior 600s.)

Each optical configuration is available in four power supply configurations:

- 230V/50Hz
- 245V/50Hz
- 208V/60Hz
- 277V/60Hz

Software note

The functions described in this manual are valid from Version 2 of the Exterior 600 software. When running earlier versions of the software, refer to an earlier revision of this user manual. These are available from <http://www.martin.com>.

Safety information

Warning! *This product is not for household use.*

It presents potential risks due to electric shock, heat and ultraviolet radiation burns, lamp explosion, falls, high-intensity light, and fire. A thorough understanding of the dangers, genuine concern for safety, and attention to detail are required to prevent accidents. Read this manual before powering or installing the fixture, follow the safety precautions listed below and observe the warnings in this manual and printed on the fixture, and always double check the safety conditions. If you have questions about how to operate the Exterior 600, please contact your Martin dealer for assistance.

Warning! *Always refer any service operation not described in this manual to a qualified technician.*

Never modify the fixture or install other than genuine Martin accessories.

Guarding against electric shock

- Disconnect the fixture from AC power before removing or installing the lamp, fuses, or any part.
- Always ground (earth) the fixture electrically.
- Use only a source of AC power that complies with local building and electrical codes and has both overload and ground-fault protection.
- Refer all service to a Martin service technician.

Preventing UV radiation and lamp explosion

- Never operate the fixture without all lenses and covers installed: an unshielded lamp emits dangerous UV radiation that can cause burns and eye damage, and it can explode without warning.
- When replacing the lamp, allow the fixture to cool for at least 20 minutes before opening the fixture.
- Do not stare directly into the light. Never look at an exposed lamp while it is lit.

- Replace the lamp if it becomes defective or worn out.

Guarding against burns and fire

- Never attempt to bypass the thermostatic switch or fuses. Always replace defective fuses with ones of the specified type and rating.
- Keep all combustible materials (for example fabric, wood, paper) at least 1 meter (39 inches) away from the fixture. Keep flammable materials well away from the fixture.
- Do not illuminate surfaces within 1 meter (39 inches) of the fixture.
- Install the fixture outdoors or in a well ventilated area.
- Never place filters or other materials over the lens.
- The exterior of the fixture becomes very hot, up to 90° C (194° F) during normal operation. Do not locate the fixture in areas where accidental contact is likely.
- Always allow the fixture to cool for 20 minutes before servicing
- Do not modify the fixture or install other than genuine Martin parts.
- Do not operate the fixture if the ambient temperature (Ta) exceeds 40° C (104° F).

Preventing injury due to falls

- When suspending the fixture above ground level, verify that the structure can hold at least 10 times the weight of all installed devices.
- Block access below the work area whenever installing or removing the fixture.
- Always use at least one fastener in each of the 4 curved mounting slots in the base.

Installation

This section describes in general terms how to mount the fixture and connect it to data and AC power. These procedures shall be performed by qualified professionals.

The chapter contains the following sections:

- “Unpacking”
- “Lamp Installation”
- “Fixture installation”

Unpacking

The Exterior 600 comes with the following items:

- Philips MSD 575 discharge lamp
- User manual

Lamp Installation

See “Installing the lamp” on page 66.

Fixture installation

This section briefly describes how to anchor the Exterior 600. The Exterior 600’s base allows the fixture to manually be panned 50° and tilted +/- 40°.

Warning! *It is the installer’s responsibility to determine the anchoring method.*

Location and orientation

The Exterior 600 may be installed outdoors, in any orientation. It shall be located at least 1 meter (39 in.) away from the surface to be illuminated and any combustible materials. The aluminum housing reaches temperatures up

to 90° C (194° F): the fixture should not be located where it can accidentally be touched.

When choosing a location for the fixture, consider that it has an ingress protection rating of 65. This means that the fixture is totally dust proof and that it is protected from water ingress to the level that moisture from low-pressure water jets from any direction cannot get into the product. However, the product is not designed to withstand:

- High-pressure water jets from any direction
- Immersion in water (or any other fluid)

The Exterior 600 requires free-circulating air for cooling. Do not bury the Exterior 600 or otherwise locate it in an unventilated space.

To achieve the full tilt range, the fixture must be installed on a pedestal at least 12 cm (4.7 in) long. To achieve the full pan range, the fixture must be anchored with 4 fasteners that can be loosened, spaced at 90° intervals as described below.

Fastener spacing and type

Warning! *Verify that the structure can bear at least 10 times the weight of all installed fixtures. Use at least one fastener in each of the 4 curved mounting slots.*

The fixture is designed to be anchored with four 10 mm (3/8 in.) bolts. Additional bolts may be used but the pan range will be reduced. Evenly space the bolts at 90° intervals, centered on a 170 mm (6 and 11/16 in.) circle, so that one bolt passes through each curved slot in the foot of the base.

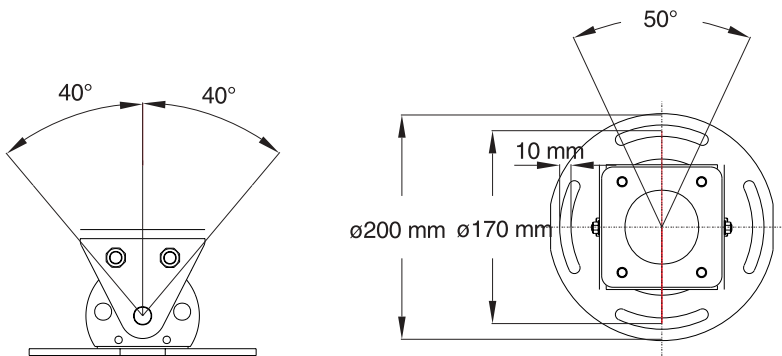

The specific hardware will depend on the installation. Consult a qualified engineer to determine a suitable anchoring method and to verify that the structure can safely bear at least 10 times the fixture's weight. In general, use high quality corrosion resistant fasteners such as zinc-plated steel,

grade 8.8 or better, together with either self-locking nuts or nuts and lock-washers.

Adjusting pan and tilt

1. To adjust the pan, loosen the anchor bolts slightly so that the fixture can turn. Manually adjust the pan position and retighten the bolts.
2. To adjust the tilt, loosen both tilt locks on either side of the base. Position the fixture and retighten the tilt lock nuts.

AC power

Power configuration

This section describes connection to AC power. Your Exterior 600 is factory-wired to one of the following settings:

- 230V/50Hz
- 245V/50Hz
- 208V/60Hz
- 277V/60Hz

Operating at the incorrect power setting can result in poor light output, greatly reduced lamp life, overheating and damage to the fixture. The factory settings are printed on the serial number label. If your local AC voltage or frequency differ from the settings for your model, then see “Changing the power settings” on page 71.

Connection to the mains supply

The Exterior 600 is equipped with a 1.8-meter (5.9 ft.) length of 3-conductor 0.75 mm² (~18 AWG) electrical cable for connection to the AC power supply. The supplied mains cable has a neoprene rubber jacket. The cable enters the fixture through a cable gland that fits 5.5-10 mm (2-4 in.) diameter cables.

Note:

If there is a breach or cut at any point along the power cable (for example at a connection point), and if this is exposed to water, moisture can be drawn up the inside of the cables due to the vacuum effect from the heat generated during operation. When installing the product outdoors, always ensure that the fixture is protected from water ingress from inside its power cable by:

- ***Protecting the connectors on the power cables in a weatherproof housing, or a weatherproof electrical junction box (see manufacturers instructions), or***

- **Replacing the supplied cable with one that connects directly inside the fixture (see “Hard wiring the fixture to the mains supply” on page 15), or**
- **Using IP65 rated cord caps (see “Installing a cord cap on the mains lead” on page 17).**

Warning! **Do not connect the Exterior 600 to an electrical dimmer system. Doing so can damage the electronics.**

For protection from dangerous electric shock, the fixture must be grounded (earthed). The AC mains supply shall be fitted with a fuse or circuit breaker and ground-fault protection.

Hard wiring the fixture to the mains supply

Prerequisites

- Use Hypalon or neoprene rubber-jacket cable. The conductor size shall be no less than 1.5 square mm (ca. 16 AWG).
- Verify that the power supply is tapped for the local AC voltage and frequency. The factory supplied rating can be found on the fixture serial number label.
- Verify that the feed cable is undamaged and rated for the current requirements of all connected devices.
- if you have any doubts about proper installation, consult a qualified electrician.
- Consult a qualified electrician if the Exterior 600 is to be connected directly to building wiring. *There shall be a switch in the circuit to turn power off when the fixture is not in use or is being serviced.*

Replacing the mains lead

1. Make sure the Exterior 600 is isolated from AC power and is cool.
2. Remove the 10 Allen screws from the rear cover plate.
3. Pull off the plate and seal.

4. Remove the 2 screws from the aluminum circuit-board bracket (A) and pull the circuit board out.

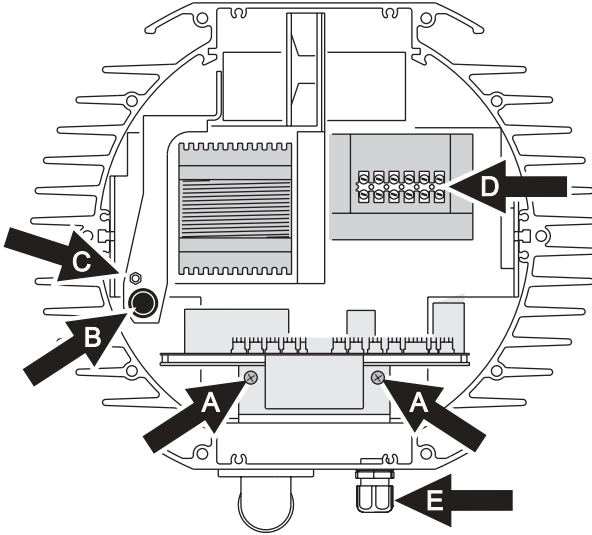

5. Unplug the power cable's brown lead from the back of the main fuse holder (B). The lead is connected with a spade plug and can be pulled off.
6. Remove the green/yellow lead from the grounding bolt (C) to the left of the ballast.
7. Disconnect the blue lead from the connection block (D) located in front of the transformer.
8. Loosen the large outer nut on the mains lead pass-through fitting (E). Cut cable ties as necessary and pull the mains lead out of the fixture.
9. Transfer the outer pass-through nut (E) to the new cable and then insert the new cable through the fitting. Pull the cable into the fixture and cut to 52 cm (20 in.) from the inside of the pass-through.
10. Remove 28 cm (11 in.) of outer insulation. Lead the cable between the fuse holder and housing (at B).
11. Install a 6.3 mm (1/4 in.) insulated female spade terminal on the live lead (brown), and plug the lead into the back of the main fuse holder (B).
12. Install a ring terminal on the ground lead (green/yellow), place the terminal on the grounding bolt to the left of the ballast (C), and replace the nut.

- Strip 6 mm (1/4 in.) of insulation from the neutral lead (blue) and screw the lead into the neutral terminal of the connection block in front of the transformer (D).

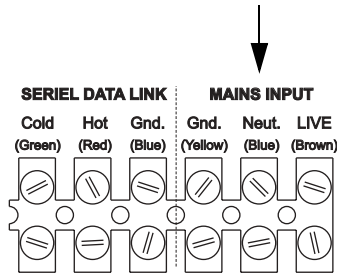

- Replace the printed circuit board (A). Bundle the wires together as before with zip ties.
- Verify that both nuts on the pass-through fitting are tight (E). Check the condition of the seal for the back cover. Replace with a new one (P/N 20600020) if the seal is torn, cracked or brittle.
- Insert the Allen screws through all holes in the cover and seal. Place the cover firmly against the body. Adjust the straight sides of the seal so that they stick out a little bit, just enough so that you can feel the seal when you run a finger across the joint.
- Cross-tighten the cover bolts. The correct torque for these bolts is 3 N.m (2.2 Ft-Lbs). With this torque, the seal will be compressed by about one-third.

The cable gland must be replaced if the outside cable diameter is larger than 10 mm or smaller than 5.5 mm. See “Cable glands” on page 59.

Installing a cord cap on the mains lead

A non-IP-rated cord cap may be installed on the mains lead for testing, service, and temporary applications. For outdoor installations an IP65-rated cord cap should be used. The following table details some commonly used wiring configurations.

Wire (EU)	Wire (US)	Pin	Marking	Screw (US)
brown	black	live	“L”	yellow or brass
blue	white	neutral	“N”	silver
yellow/green	green	ground		green

Following the cord cap manufacturer's instructions, connect the yellow and green wire to ground (earth), the brown wire to live, and the blue wire to neutral. The following table shows some pin identification schemes; consult an electrician if you have any doubts about proper installation.

Warning! For protection from dangerous electric shock, the fixture must be grounded (earthed). The AC mains supply shall be fitted with a fuse or circuit breaker and ground-fault protection.

Data link

A data link is required for DMX controller operation, and for synchronized stand-alone operation of multiple fixtures.

Cable and junctions

The Exterior 600 provides a dual 1.8 meter (5.9 ft.) 24 AWG cable with locking 3-pin male and female XLR connectors for data connection. The male cable is the data input and the female cable is the data output. The connectors are wired pin 1 to shield (gnd.), pin 2 to signal - (cold), and pin 3 to signal + (hot).

Use RS-485 data cable designed for outdoor use to extend the link. RS-485 cable has low capacitance and a characteristic impedance of 85 to 150 ohms. It is electrically shielded and has at least 1 twisted-pair of conductors. The minimum wire size is 0.2 mm² (24 AWG) for runs up to 300 meters (1000 ft.) and 0.322 mm² (26 AWG) for runs up to 500 meters (1640 ft.).

Warning! *Fixtures produced from the middle of 2004 will be supplied with Neutrik NC3MX-HD-B and NC3FX-HD-B weatherproof IP65-rated XLR connectors.*

Connectors on earlier models are not weatherproof, and if these connectors are exposed to water, moisture can be drawn up the inside of the cables due to the vacuum effect from the heat generated during operation. When installing the product outdoors, always ensure that the fixture is protected from water ingress from inside its data cable by:

- ***Protecting the connectors on the data cable in a weatherproof housing (or a weatherproof electrical junction box), or***
- ***Using IP65 rated XLR cable and connectors (such as the NC 3 MX-HD-B and NC 3 FX-HD-B produced by Neutrik).***

Adaptors

Adaptors may be required to connect the Exterior 600 to the controller or other 5-pin devices. Adaptor cables for indoor use are available from Martin. The adaptor cables are wired as shown below.

5-pin to 3-pin Adaptor	
Male	Female
1	1
2	2
3	3
4	
5	
P/N 11820005	

3-pin to 5-pin Adaptor	
Male	Female
1	1
2	2
3	3
	4
	5
P/N 11820004	

Splitter/Amplifiers

A device such as the Martin 4-Channel Opto-Isolated RS-485 Splitter/Amplifier may be used to branch the data link and/or extend its length. Do not use a “Y” connector to split the link.

Terminators

Termination of the data link is required for trouble-free communication. For temporary installations, this can be achieved with an IP65 weatherproof male termination plug inserted into the data output cable of the last fixture in each chain. A termination plug is simply an XLR connector with a 120 ohm resistor soldered across pins 2 and 3.

For permanent terminations, the link can be terminated inside the last fixture in each chain, using a 120 ohm resistor across the hot and cold data

terminals on the main circuit board, or across the corresponding terminals on the connection block (at position E).

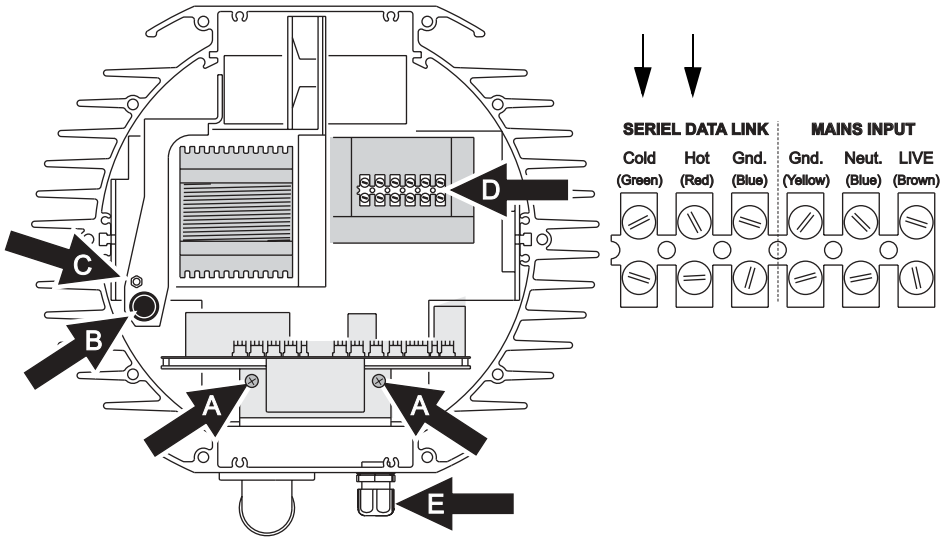

If you terminate the data link internally then you will need to change the supplied dual cable (with male and female XLR connectors) to a single cable with a male connector. The process for changing the XLR cable is very similar to that for changing the power lead (see “Hard wiring the fixture to the mains supply” on page 15). The cable enters the fixture (at position E) and the leads are connected to the connection block (at position D).

Building a data link

To build a data link:

1. Connect a data cable to the controller's data output. A male 5-pin to female 3-pin adaptor may be required. Lead the data cable from the controller to the first fixture and plug it into the male data cable.
2. Connect the output of the fixture closest to the controller to the input of the next fixture. Continue in this manner. Up to 32 fixtures may be connected output to input.
3. Terminate the link as described above, at the output of the last fixture in the chain.

Fixture settings

This section describes how to set the control address, clock, and other fixture personalities. There are three ways to define fixture settings:

Multi-Utility Manager

Multi-Utility Manager (MUM) is a PC software application supplied with a DABS1 USB-to-XLR communications adaptor. We recommend MUM because it provides an intuitive, easy-to-use, graphical user interface.

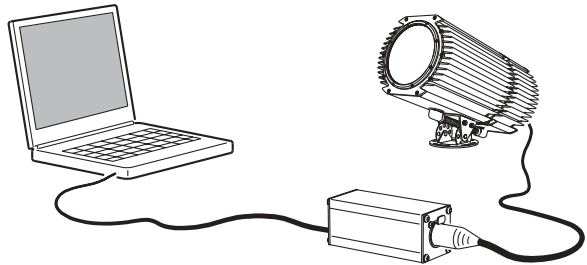

One limitation with MUM is that you can only connect to, and set-up, one fixture at a time. See “Defining fixture settings using MUM” on page 24.

**Martin
MP-2
Uploader**

The MP-2 uploader can be loaded with the Exterior 600's control software and connected to the fixture or data link.

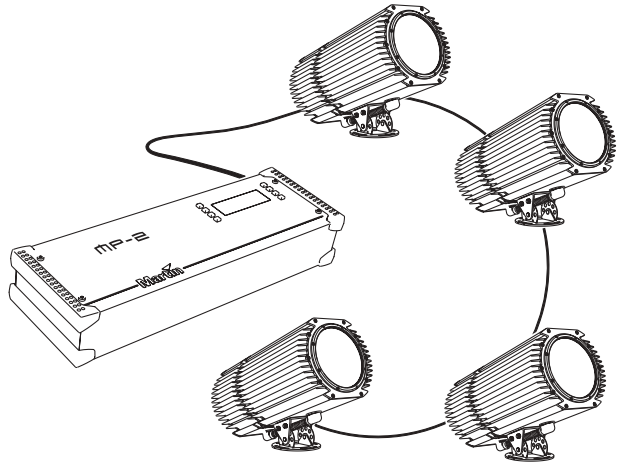

When working with multiple fixtures the Uploader allows you to apply settings globally to multiple fixtures on a data link.

The MP-2 provides a text-based interface and the fixtures do not provide feedback to the uploader. Therefore, the current settings of the fixture can only be "read" by observing the behavior of the fixture.

Refer to the respective MP-2 user manual for more information.

**DMX
Address
Device**

DMX Address Device (DAD) is a hardware device that can be used to set the DMX address of one Exterior 600 at a time.

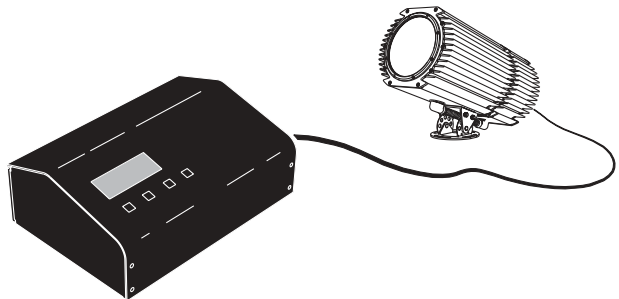

If you need to set other fixture setting - such as the internal clock - then you will also need to use an MP-2 Uploader or MUM to completely set-up the fixture.

Refer to the *DMX Address Device user manual* for more information.

Defining fixture settings using MUM

Using the MUM you can connect to and set up one fixture at a time. Refer to the *MUM user manual* for instructions on installing and starting the MUM application.

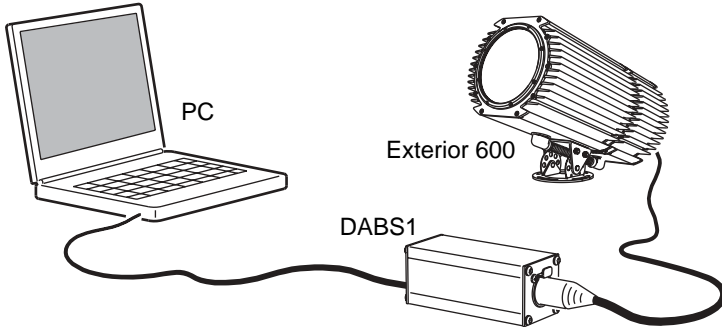

Support for the MUM application is available from Version 2 of the Exterior 600 software.

To get started:

1. Connect a DABS1 adaptor to your PC.
2. Connect the DABS1 adaptor to your Exterior 600.
3. Power on the Exterior 600 and start the MUM application. The application will automatically detect an Exterior 600 if it is powered-on and connected to your computer via a DABS1 adaptor. It will also retrieve the current settings on the fixture and display them.

Clock

The Exterior 600 has a battery operated 24-hour clock that can start and stop stand-alone operation.

To set the clock:

1. Using MUM, click on the **Fixture information** button:

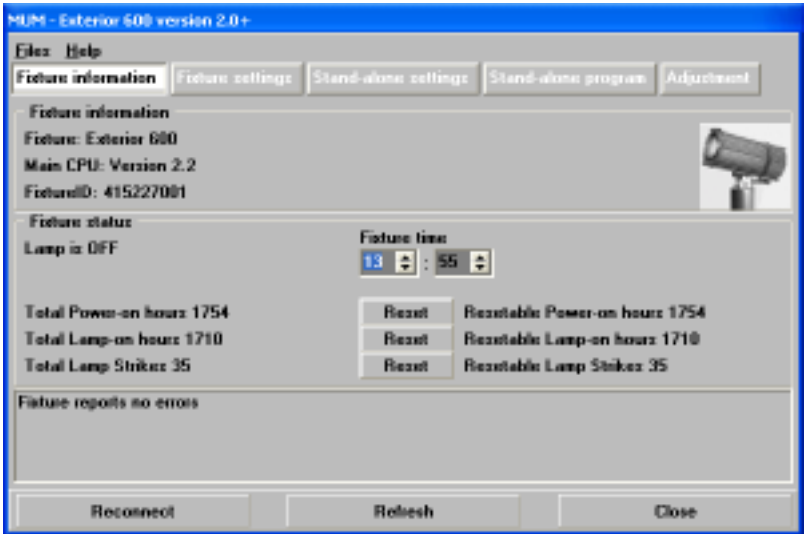

2. Using the two **Fixture time** spin buttons set the fixture to the current time (expressed in the 24-hour clock in hours and minutes). The time will be updated in the fixture in real-time.

Fixture settings

To set the additional fixture settings, click on the **Fixture settings** button:

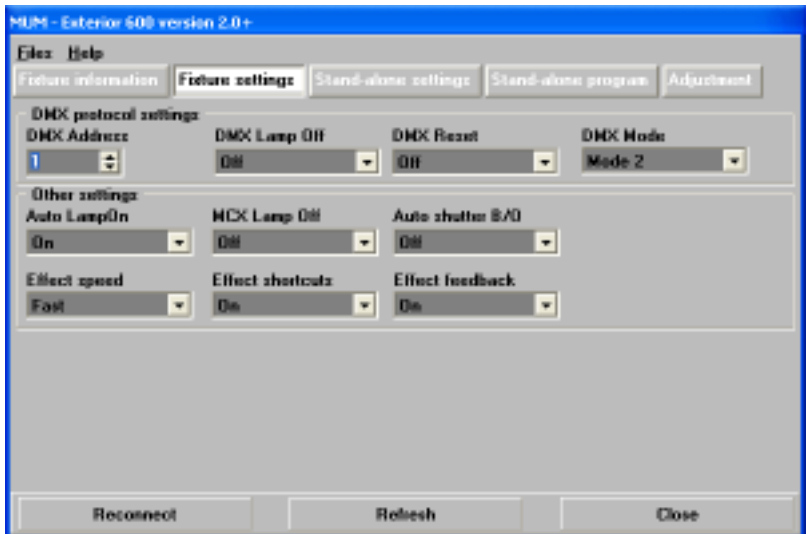

In most situations the default settings will appropriate.

DMX Protocol settings

These are described in “Preparing a fixture for DMX control” on page 46. Refer to this section if you will be operating the Exterior 600 with a DMX control device.

Automatic lamp on

When the **Automatic Lamp On** personality is on, the fixture turns on the lamp within 90 seconds of power on. When set to off (the default setting), a lamp-on command is required to turn on the lamp.

MC-X lamp off

By choosing the option **MCX Preset 7 Key** from the **MCX Lamp off** field you enable button 7 on an MC-X controller to be used to control the lamp off function.

Auto shutter B/O

The shutter will “assist” the dimmer black out (On - default) or will not be affected by the dimmer setting (Off)

Effect speed

Effects are performed quickly (Fast - default) or slowly (Safe).

Effect shortcuts

This determines whether the wheel takes the shortest path to the next position or turns in one direction only. This is on by default.

Effect feedback

Effect feedback is a real-time position correction system that automatically corrects the position of the effect wheels. This is on by default.

General operation

When the Exterior 600 is connected to power it will reset.

Lamp operation

Avoid turning on several lamps at once.

To optimize lamp life, always allow the lamp to warm up fully before turning it off.

For optimum lamp life, turn off lamp power whenever illumination is not required for extended periods of an hour or more. Fixture power may remain on when not in use.

After being turned off, the lamp must cool for at least 8 minutes before it can be turned back on. “Lamp on” commands sent within 8 minutes of a “lamp off” command are stored and then attempted again after the time has elapsed.

Cold weather operation

When the temperature is expected to fall below freezing, leave the fixture powered on when not in use to keep the electronics warm. The lamp, however, may be switched off.

The LEDs and fixture operating status

Two LEDs on the rear panel display the fixture status. Normal operation is indicated by two green LEDs. See Table 1 for other status messages.

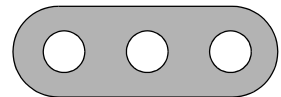

LED 1 LED 2 SENSOR

The LEDs flash off for a brief instant at regular intervals to prevent false readings when the light sensor samples the light level.

Appearance	Message, LED 1	Message, LED 2
Steady green	Effects OK	Data OK.
Steady red	-	Invalid data/no data
Steady yellow	Waiting for upload, or upload in progress	Waiting for upload, or upload in progress
Flashing yellow	Reset in progress	Reset in progress
Flashing red & green	Contact a service technician	
Off	-	No data detected

Table 1: LED status messages

The three-digit version number (*major.minor.build*) of the installed firmware is displayed by the LEDs on power up; the number of:

- Red flashes in LED 1 indicate the major number, followed by,
- Green flashes in LED 2 indicate the minor number, followed by,
- Red flashes in LED 2 indicate the build number (only used for beta releases)

For example, if the firmware version is 1.3.0, LED 1 flashes red once and LED 2 flashes green three times.

Fixture control methods

The Exterior 600 can be controlled:

- With DMX signals from a DMX control device such as a DMX recorder or DMX controller. This is described in “Section 3. DMX control” on page 45.
- Using stand-alone programming. There are two ways of programming and storing a show in the fixture itself:
 - a. From a personal computer, using the Martin MUM software application, or
 - b. Via an MP-2 Uploader

Stand-Alone programming is described in “Section 2. Stand-Alone operation” on page 31.

Color matching Exterior 200s and 600s

If you are running Exterior 200 and Exterior 600 fixtures together in the same installation, colors will not match when the same CMY values are used, because these fixture use different lamps.

Generally speaking, the relatively:

- Higher-powered lamps used in the Exterior 600 result in deeper colors in the cold colors of the spectrum.
- Lower-powered lamp used in the Exterior 200 will give deeper colors in the warm colors of the spectrum.

The following table gives some approximate values for color matching:

Color	Exterior 600 (with MSD 575 lamp)	Exterior 200 (with CDM lamp)
White	Magenta 25 Yellow 44	Open
White	Open	Cyan 74
Yellow	Yellow 241 Magenta 16	Full yellow
Magenta	Magenta 100 Yellow 68	Full magenta
Cyan	Full cyan Magenta 25 Yellow 44	Full cyan
Red	Full magenta Full yellow	Full yellow Magenta 215
Green	Cyan 241 Yellow 241	Full cyan Full yellow
Blue	Full cyan Full magenta	Cyan 255 Magenta 191

SECTION 2. STAND-ALONE OPERATION

This section contains the following chapters:

- “Stand-Alone programming overview” on page 32
- “Programming from a PC using MUM” on page 35
- “Stand-Alone show playback” on page 41
- “Synchronous triggering during Stand-Alone operation” on page 43

Stand-Alone programming overview

Stand-alone is a mode where the fixture executes color changes at set intervals and speeds, at pre-defined periods during the day, and/or when the light level falls below a defined level. The term *stand-alone* is used to mean that the Exterior 600 is not connected to a control device, but is pre-programmed with a series of up to 20 scenes that play continuously in a loop. The term 'stand-alone operation' can be applied to a single fixture, or to multiple fixtures operating synchronously.

An Exterior 600 running a stand-alone show can perform synchronized scene changes (triggered by a master fixture) with up to 31 other Martin fixtures of the following types:

- Exterior 200
- Exterior 600
- FiberSource CMY150
- Imager series
- Alien 02 series
- MiniMAC Maestro

These fixtures all have their own shows individually programmed, but have scenes synchronously triggered by a one fixture. Synchronous operation of multiple fixtures requires that they be connected on a data link.

About scene timing

Each scene has a dynamic part - the fade - during which effects move to the scene's programmed positions, and a static part - the wait - where effects do not change.

The duration of the fade and wait is programmed individually for each scene. The fade time may be 0 - 120 seconds; the wait time may be 1 second to 12 hours. The total time it takes a scene to execute is the sum of the fade and wait times.

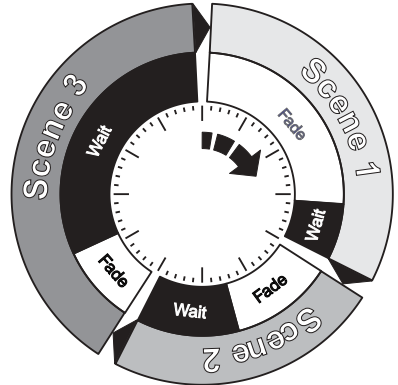

When operating multiple fixtures synchronously, the wait time is determined by the fixture that issues scene change commands. It does this when it reaches the end of each scene wait time. Every other fixture fades and waits at its own rate and then remains in the “wait state” until receiving a start scene xx command. When programming in synchronous triggering situations, keep in mind that in order to keep things as simple as possible there are two rules of thumb that will make life much easier; try to ensure that:

1. Every fixture has the same number of scenes.
2. Respective scene times are a few seconds longer on the fixture that issues triggering commands.

The rules used in the algorithm are detailed in “Synchronous triggering during Stand-Alone operation” on page 43.

Synchronizing scene changes for multiple Exterior 600s

In situations where you are running multiple Exterior 600s on a data link it is possible to synchronize scene changes.

It is important to note that each individual fixture must be programmed with a show and that the only commands that are passed are scene change commands. No data about the look of the scene is passed between fixtures.

Programming methods

The Exterior 600 provides two stand-alone programming methods; using the:

- Martin MUM application from a personal computer (recommend because it provides an intuitive, easy-to-use, graphical user interface), or an
- MP-2 Upload device. See the MP-2 user manual for further information.

If you are programming a group of fixtures to perform the same scenes with synchronized-triggering then we recommend that you either:

- Use an MP-2 Uploader to program the same show on all fixtures on the network simultaneously (and then you can assign their individual DMX address afterwards), or
- Use MUM to program a single fixture, download and save the fixture settings to a file on your PC, and then upload the stand-alone program and fixture settings to each subsequent fixture that you connect to.

Programming from a PC using MUM

The programming of scenes, and setting up of master/slave relationships, can be performed from a personal computer using the MUM application. The computer is connected to a fixture via a DABS1 USB-to-XLR adaptor, used to program the stand-alone settings for that fixture, and then removed. Once a fixture is subsequently switched on it can automatically run the scenes in its program in a loop, according to the triggering criteria you have specified (time of day, and/or light level).

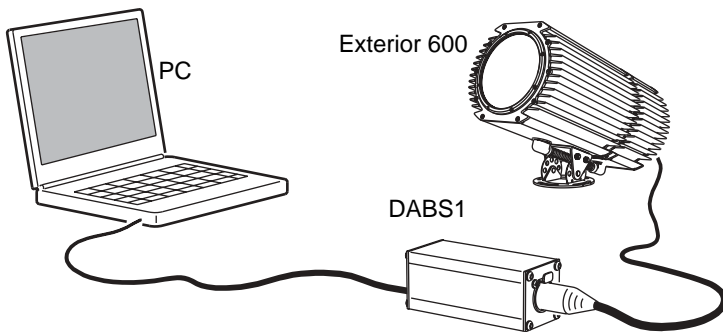

If you are not familiar with the use of MUM, then it is recommend that you familiarize yourself with it by reading the *MUM user manual*.

Getting started

To get started:

1. Connect a DABS1 adaptor to your PC.
2. Connect the DABS1 adaptor to your Exterior 600.
3. Power on the Exterior 600 and start the MUM application. The application will automatically detect an Exterior 600 if it is powered-on and connected to your computer via a DABS1 adaptor. It will also retrieve the current settings on the fixture and display them.

Stand-Alone Settings

The fixture needs to be configured to know if and when to activate a stand-alone program:

Click **Stand-alone settings** to display the following window.

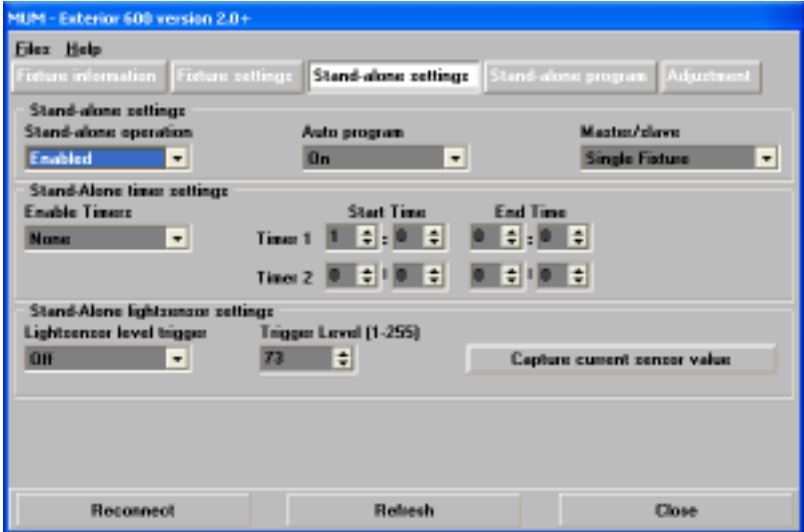

The following options are available:

- | | |
|--|---|
| Stand-alone operation | Activates or deactivates stand-alone operation. |
| Auto program | Enables the stand-alone program to start automatically when the fixture is powered-on. If a DMX signal is removed from the fixture and this setting is enabled, the fixture will resume stand-alone operation. |
| Master/slave | Specifies if the fixture is a single, “master” (triggering), or “slave” (receiving trigger signals) fixture.
<i>No more than one fixture may be the master. Any fixture on the link, however, regardless of its position, may be the master. All other fixtures must be set as slave fixtures.</i> |
| Stand-alone timer settings | See “Setting a timer trigger” on page 37. |
| Stand-alone light sensor settings | “Setting a light-level trigger” on page 37. |

Synchronizing scene changes for multiple fixtures

In situations where you are running multiple fixtures on a data link it is possible to synchronize scene changes (for fixtures that support this functionality - see “Stand-Alone programming overview” on page 32). Read this section if this applies in your case.

One controlling fixture triggers simultaneous program start and scene changes in the other fixtures. Each fixture stores its own program, and the controlling fixture triggers simultaneous program start and scene changes, in a cycle, based on its own program.

Each fixture will run its program repeatedly, changing scene when prompted to by the controlling fixture, or until the controlling fixture finishes its own program and signals that all fixtures should start from the first scene once again.

It is important to note that each individual fixture must be programmed with a show and that the only commands that are passed are scene change commands. No data about the look of the scene is passed between fixtures.

Automatically triggering stand-alone operation

Stand-alone operation can be set for one or two periods during a 24 hour period, or for a light level.

Setting a light-level trigger

The option **Lightlevel sensor trigger** must be set to **On**.

Stand-alone operation can be set for a specific light level using the **Trigger level** spin button, or captured using the built-in light sensor (press **Capture current sensor value** to do this). If the light levels fall below the specified level then operation starts.

If both the timer *and* the light-level trigger are used, operation starts whenever it is darker than the light-level setting, and within the times set.

To avoid false triggering by sudden light changes, for example from automobile headlights, the light level must remain above or below the trigger threshold for 5 minutes.

Setting a timer trigger

Stand-alone operation can be set for one, or two, periods, during a 24 hour period, using the built-in clock.

If both the clock *and* the light sensor are used, operation starts, within the times set, and whenever it is darker than the light-level setting.

The first thing to do is to set the correct time. See “Clock” on page 24.

You can set timer operation for a single period, or for two periods, for example, one period in the morning, and one period in the evening.

Programming effects in scenes

The programming of effects is performed using the Stand-Alone program controls:

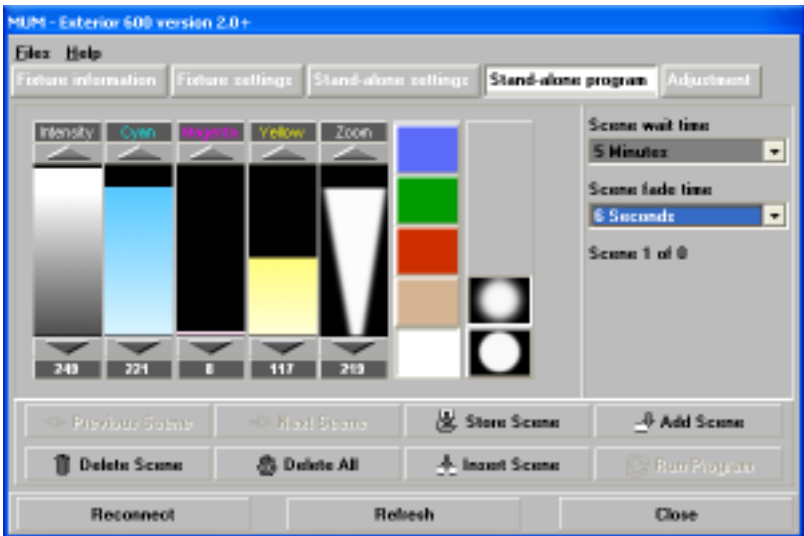

The following options are available:

- Intensity** The dimmer provides smooth, high-resolution 100 percent dimming.
- Cyan
Magenta
Yellow** CMY color mixing. The CMY color mixing system is based on graduated cyan, magenta, and yellow color filters. A continuous range of mixed colors may be achieved by varying the amount of each filter from 0 to 100%. Note that mixing 3 colors results in a loss of light - the light is blacked out when all 3 colors are fully applied. For maximum brightness, mix only 2 colors at a time.
- Zoom** The lens may be driven forwards or backwards to vary the size of the beam. The zoom function only has a noticeable effect in the following Exterior 600 models:
- Exterior 600, 18-25°
 - Exterior 600, 22-38°
- The zoom function has little effect with models containing other beam angles.

Filter color	Select positions on the color wheel using the five buttons. The color wheel has red, green, and blue dichroic color filters plus a 5600K to 3400K color correction filter and open white. It may be used together with CMY color mixing to increase color saturation. The wheel scrolls continuously, allowing for split-color effects, or in full steps. It also rotates continuously in both directions at different speeds.
Frost	The two buttons are used to set the frost effect on and off. The frost filter has little effect when used with the 65° or 100° Exterior 600 models.
Scene fade time	The fade time, anything from 0 to 120 seconds, is the time it takes to change from one color to another.
Scene wait time	This is the duration a color is applied. A wait time can be from 1 second to 12 hours.

When operating multiple fixtures in synchronized-triggering mode, the wait time in “slave” fixtures is disregarded, and is determined by the triggering, or “master” fixture. Each fixture fades at its own rate and then waits for the master to signal a scene, or program, start before continuing.

When programming a triggering (“master”) fixture, keep in mind that its total scene times should be equal to or longer than the fade times of the other fixtures. You will get unpredictable results if, for example, a scene is programmed in the master to last 10 seconds and in other fixtures to fade for 15 seconds.

Scene management

Once you have specified a mix of effects, you can store the scene using the options available under the Program menu:

Store scene	Save settings in the current scene.
Add scene	Save settings in a new scene at the end of the sequence.
Insert scene	Save settings in a new scene before the current scene, which moves up a number. <i>Tip: Think of the Add and Insert commands as Save commands, to be used as the last step after programming all effects.</i>
Delete scene	Remove the current scene from memory. Scenes above the deleted scene move down a number.
Next scene	Step to the next scene.
Previous scene	Step to the previous scene.
Delete all	Remove all scenes from the fixture memory.
Run program	Run the scenes in the current program.

When the program is run, scenes execute in a continuous, ascending loop.

Note that, if a “slave” fixture has:

- Fewer scenes than the master fixture, it will run these in a cycle continuously, until the master fixture signals that the program should start from the beginning again.
- More scenes than the master fixture, then the additional scenes will never run, because the program will reset to the first scene when the master starts its program from the beginning.

Programming the same stand-alone show on multiple fixtures

Although you can only connect to and program a single fixture at a time using the MUM, you can use it to program a single fixture, download and save the fixture settings to a file on your PC, and then upload the stand-alone program and fixture settings to each subsequent fixture that you connect to. This is useful if you have a group of fixtures of the same type that will run the same stand-alone show.

Stand-Alone show playback

Starting show playback automatically at fixture power-on

Execution of the pre-programmed scenes in a loop will automatically resume when the fixture is powered-on if stand-alone is enabled (see “Stand-Alone Settings” on page 36) and the automatic lamp-on function is enabled (see “Fixture settings” on page 25).

Scene execution using the optional MC-X

The MC-X is an optional remote control unit that is available from Martin. Once the remote controller is connected, 7 scenes can be conveniently called up on the MC-X's buttons.

Enabling MC-X control

Using an MP-2

For each fixture:

1. Disable stand-alone operation on each fixture, select `SA / run / OFF` and press [enter]. Press [menu] to exit the SA menu.
2. Using the `Per / nno` menu it is possible to set button 7 on the MC-X to control the lamp off function. See “Specifications” on page 79.

Using MUM

For each fixture:

1. Disable stand-alone operation. See “Stand-Alone Settings” on page 36, under the chapter “Programming from a PC using MUM”.

2. Enable lamp-on from the MC-X. See “MC-X lamp off” on page 26 in the section “Defining fixture settings using MUM”.

Connecting and using the MC-X Controller

1. Connect the MC-X controller to the Exterior 600’s data network. If multiple Exterior 600s are connected, plug the controller into the first fixture in the link.
2. To trigger scenes 00-06, press the numbered preset buttons on the MC-X.
3. To have each fixture run its own routine, press [Auto].

DMX controller override during stand-alone show playback

If an Exterior 600 is connected to a DMX controller and receives DMX signals during show playback, the Stand-Alone show will stop running and the fixture will respond to the DMX controller. DMX signals always have priority over the running of a Stand-Alone show.

Synchronous triggering during Stand-Alone operation

Note ***This chapter details the rules that are used in Stand-Alone synchronous triggering. It is not necessary to read this chapter unless you require help with problem diagnosis or unless you otherwise need a detailed understanding of the algorithm used for synchronous triggering.***

The rules are as follows:

1. Every fixture can have up to 20 on-board scenes with individual fade and wait times.
2. Scenes are numbered from 0 to 19.
3. A scene contains a fade-section, followed by a wait-section.
4. When running "synchronous triggering" one Exterior 600 issues commands to the other Exterior 600s to "go to scene xx", where xx is the scene number that master will execute next.
5. If a slave has fewer scenes than the master, it will derive which scene to go to by dividing the number of the scene it has been commanded to go to (scene 5, for example) by the total number of scenes that the slave fixture has (4, for example) in whole numbers (no decimal places). In this example 5 divided by 4 results in 1, with 1 remainder. This remainder will be the number of the scene that the slave fixture starts - scene 1. Generally though, when a Slave fixture reaches its own last scene before the Master fixture, a "go to scene x" message will result in the first scene being played.

6. If a slave has more scenes than the master calls, the last scenes in the slave will never be executed, as is the case with scene S4 in the following example.

F=fade, W=wait Timeline =>

Programmed in Master	M0	M1	M2	M3	
	F W	F W	F W	F W	
Programmed in Slave	S0	S1	S2	S3	S4
	F W	F W	F W	F W	F W
Result	M0	M1	M2	M3	
	F W	F W	F W	F W	
	S0	S1	S2	S3	
	F W	F W	F W	F W	

7. A slave fixture will not listen for the next message from the master fixture before it has finished its current scene. This may result in a slave skipping a scene if slave has a longer scene time than master. Note that in the following example the scenes in the Slave run out of their programmed sequence because scenes 0 and 2 on the Slave are longer than the corresponding scenes on the Master.

M=master, S=slave
F=fade, W=wait Time >

Programmed	M0	M1	M2		
	F W	F W	F W		
Slave	S0	S1	S2		
	F W	F W	F W		
Result	M0	M1	M2	M0	M1
	F W	F W	F W	F W	F W
Slave	S0	S2	S1
	F W	F W	F W

SECTION 3. DMX CONTROL

This section contains the following chapters:

- “Preparing a fixture for DMX control” on page 46
- “DMX controller operation” on page 49
- “DMX protocol” on page 54

Preparing a fixture for DMX control

There are a range of DMX specific settings that you need to set. These are described in this chapter. You can use a personal computer (via the MUM application), an MP-2 or a DAD to prepare your Exterior 600. We recommend using the MUM because it has a graphical-user interface that is easy to use (see the following illustration).

Follow the instructions in “Fixture settings” on page 22 to choose and connect a setting device and then refer to this chapter for information about DMX specific settings.

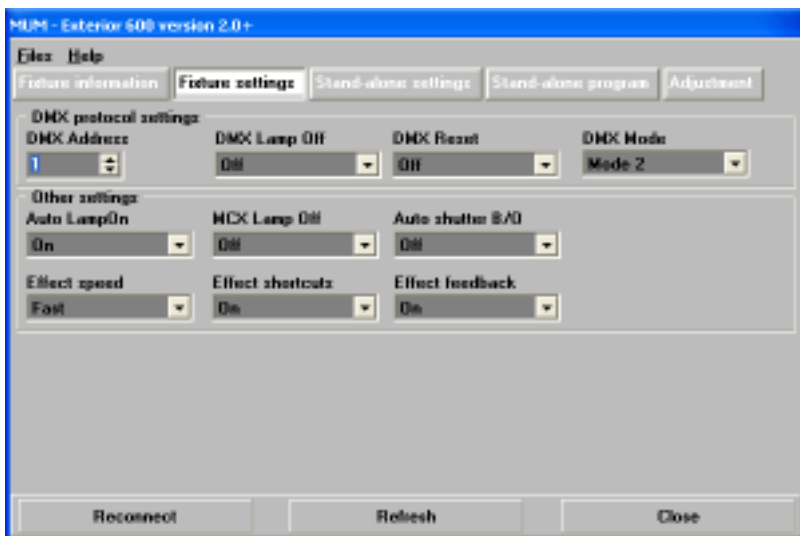

DMX address

The DMX address, also known as the control address, or start channel, is the first channel used to receive instructions from the controller. Each fixture needs its own control address set, and uses this address and subsequent

control channels to receive instructions from a controller. The Exterior 600 uses eight or nine control channels.

The control address, also known as the start channel, is the first channel used. The Exterior 600 uses eight channels of control data (in mode 1). It reads the data on the start channel and the next seven channels. If the control address is set to 100, the fixture uses channels 100, 101, 102, 103, 104, 105, 106, and 107. Channel 108 would be the control address for the next fixture.

If two or more fixtures are set up with the same address, they will receive the same instructions and should behave identically. Setting up identical fixtures with the same address is a good tool for troubleshooting unexpected behavior and an easy way to achieve synchronized action.

To set the DMX address use the **DMX Address** spin button. The fixture address is updated in real time.

DMX lamp off option

When the DMX Lamp-off personality is on (the default setting), lamp power can be turned off from the controller by setting channel 1 to a decimal value from 248 to 255. When set to off, the lamp-off command executes only if channels 3, 4, and 5 are set to values from 230 to 232.

DMX reset option

When the DMX Reset personality is on (the default setting), the fixture can be reset from the controller by setting channel 1 to a decimal value from 208 to 217. When set to off, the reset command executes only if channels 3, 4, and 5 are set to values from 230 to 232.

DMX mode

The Exterior 600 has two DMX modes of operation:

- Mode 1** Use 8 DMX channels and provides *tracking* control of the fixture.
- Mode 2** Uses 9 DMX channels and provides both *tracking* and *vector* control. (Recommended)

The speed at which effects fade, that is, move from one position to another, can be controlled in two ways known as tracking control and vector control:

- With *tracking* control, fades are programmed using the controller's fade time. The controller divides the fade into small pieces that the fixture "tracks." The Exterior 600 has a digital filter algorithm that averages several updates to ensure smooth movement.
- *Vector* control provides a way to program fades on controllers without programmable fade times or cross-faders. With vector control, instead of breaking up the movement into many small positions, the controller sends one position value along with a speed value that is programmed on a separate channel. Vector control may provide smoother fades than tracking control with some controllers, particularly on very slow fades.

Using DMX mode 2 you are able to switch between tracking and vector control, but you cannot use both at the same time.

DMX controller operation

The Exterior 600 may be programmed and operated with any lighting controller that is compatible with the USITT DMX standard. This section describes how to operate the fixture with a controller.

Refer to “Data link” on page 19 for connection requirements and the “DMX protocol” on page 54 for specific control values.

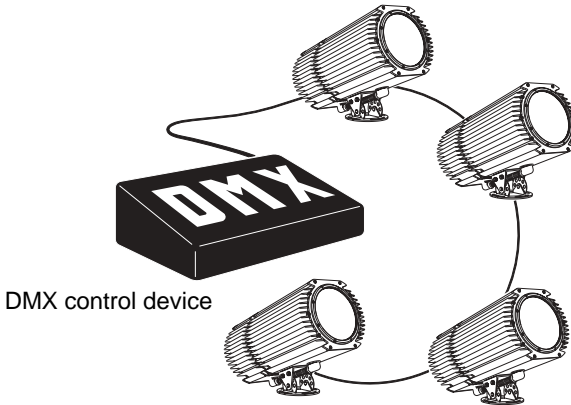

This chapter contains the following sections:

- “Effect operation” on page 50
- “Lamp” on page 51
- “Color” on page 51
- “Dimmer” on page 52
- “Shutter” on page 52
- “Zoom” on page 52
- “Beam shaper and frost” on page 53

Important: *If an Exterior 600 is connected to a DMX controller and receives DMX signals during stand-alone show playback, the stand-alone show will stop running and the fixture will respond to the DMX controller. DMX signals always have priority over the running of a stand-alone show.*

Effect operation

The fixture resets effects to their “home” position when the Exterior 600 is powered on. The Exterior 600 can also be reset from the controller on channel 1. If the DMX Reset personality is off (see “DMX reset option” on page 47), the reset command only works if each of the CMY channels is set to a DMX value from 230 to 232.

Speed

The speed at which effects fade, that is, move from one position to another, can be controlled in two ways known as tracking control and vector control. These are explained in “DMX mode” on page 47.

Using DMX mode 2 you are able to switch between tracking and vector control:

- Tracking control is enabled by setting channel 9, the speed channel, to a decimal value from 0 to 2. Fades are then programmed using the controller’s cross-faders. The Exterior 600 has a digital filter algorithm that averages several updates to ensure smooth movement.
- A vector speed is programmed by setting the speed channel to a decimal value from 3 (fastest) to 245 (slowest). The speed setting applies to dimmer and color fades. When using vector control, the controller cross-fade time, if available, must be 0.

Feedback

An on-the-fly position correction system automatically corrects the position of the effect wheels. This feature can be disabled by turning effects feedback off (see “Effect feedback” on page 26), but this is not recommended.

Shortcuts

The shortcuts setting (see “Fixture settings” on page 25) determines whether the effect wheels take the shortest path between two positions, crossing the open position if necessary, or always avoid the open position. The setting may be overridden on the speed channel (only available in DMX mode 2 - see “DMX mode” on page 47).

Lamp

Lamp on

With the default setting, the lamp remains off until a “lamp on” command is sent from the controller. To have the lamp strike automatically within 90 seconds of powering on, switch the Automatic Lamp On personality to on (see “Fixture settings” on page 22).

A large peak of electric current is drawn for an instant when striking a discharge lamp. Striking many lamps at once may cause a voltage drop large enough to prevent lamps from striking and/or trip circuit breakers. When striking multiple lamps, program a sequence that strikes lamps one at a time at 5 second intervals. If Automatic Lamp On is enabled, there is a delay of up to 90 seconds that is determined by the fixture address.

Lamp off

The lamp can be turned off from the controller by sending a “lamp off” command on channel 1. If the DMX Lamp Off personality is off (see “DMX lamp off option” on page 47), the command only works if each of the CMY channels (3, 4, and 5) is set to a DMX value from 230 to 232.

After being turned off, the lamp must cool for at least 8 minutes before it can be turned back on. “Lamp on” commands sent within 8 minutes of a “lamp off” command are stored and then executed after the time has elapsed.

Color

Color wheel

The color wheel has red, green, and blue dichroic color filters plus a 5600K to 3400K color correction filter and open white. It may be used together with CMY color mixing to increase color saturation. The wheel scrolls continuously, allowing for split-color effects, or in full steps. It also rotates continuously in both directions at different speeds.

Setting the color speed to “blackout” in mode 2 causes the shutter to black out the light while the wheel moves.

CMY subtractive color mixing

The CMY color mixing system is based on graduated cyan, magenta, and yellow color filters. A continuous range of mixed colors may be achieved by

varying the amount of each filter from 0 to 100%. Note that mixing 3 colors results in a loss of light - the light is blacked out when all 3 colors are fully applied. For maximum brightness, mix only 2 colors at a time.

Random color mixing

Random color mixing with the CMY system at slow, medium, and fast speeds is available on channel 6. These random commands take precedence over values set on the cyan, magenta, and yellow channels.

Dimmer

The mechanical dimmer provides smooth, high-resolution 100 percent dimming.

Shutter

The high-speed mechanical shutter opens and closes the light instantly. Light can be flashed at up to 8 Hz and there is a DMX-callable random strobe function.

If the auto shutter B/O function is enabled (see “Fixture settings” on page 25), the shutter, which is faster than the dimmer, automatically closes when the dimmer receives a command to close “instantly,” to provide faster blackouts.

Zoom

The lens may be driven forwards or backwards to vary the size of the beam. The zoom function only has a noticeable effect in the following Exterior 600 models:

- Exterior 600, 18-25°
- Exterior 600, 22-38°

The zoom function has little effect with models containing other beam angles.

Beam shaper and frost

The:

- Beam shaper flattens and widens the beam into an oval, which rotates 90°.
- Frost filter softens the beam.

These two effects are on the same wheel so they cannot be combined.

The beam shaper and frost have little effect when used with the 65° or 100° Exterior 600 models.

DMX protocol

Start code = 0

DMX channel	Value	Percent	Function
1	0 - 19	0 - 7	Shutter, Strobe, Reset, Lamp On/Off Shutter closed
	20 - 49	8 - 19	Shutter open
	50 - 112	20 - 44	Strobe, fast → slow
	113 - 127	44 - 50	Shutter closed
	128 - 147	50 - 58	Random strobe, fast
	148 - 167	58 - 65	Random strobe, medium
	168 - 187	66 - 73	Random strobe, slow
	188 - 207	74 - 81	Shutter closed
	208 - 217	82 - 85	Reset fixture*
	218 - 227	85 - 89	Shutter closed
	228 - 237	89 - 93	Lamp power on
	238 - 247	93 - 97	Shutter closed
	248 - 255	97 - 100	Lamp power off* Note: Apply for ≥ 5 seconds
	2	0 - 255	0 - 100
3	0-255	0 - 100	Cyan White → Cyan
4	0-255	0 - 100	Magenta White → Magenta
5	0-255	0 - 100	Yellow White → Yellow

DMX channel	Value	Percent	Function
6	0 - 40	0 - 16	Color Wheel
	40 - 80	16 - 31	Continuous Scroll
	80 - 120	31 - 47	White → Color 1
	120 - 160	47 - 63	Color 1 → Color 2
			Color 2 → Color 3
			Color 3 → Color 4
	161 - 165	63 - 65	Stepped Scroll
	166 - 170	65 - 67	Color 4 - Blue
	171 - 175	67 - 69	Color 3 - Green
	176 - 180	69 - 71	Color 2 - Red
181 - 185	71 - 73	Color 1 - Color temperature correction	
		White	
186 - 214	73 - 84	Rotation	
215 - 243	84 - 95	CW, fast → slow	
		CCW, slow → fast	
244 - 247	96 - 97	Random Color (uses CMY)	
248 - 251	97 - 98	Random color fast	
252 - 255	99 - 100	Random color medium	
		Random color slow	
7	0 - 2	0 - 1	Beam Shaper
	3 - 170	1 - 67	Open
	171 - 255	67 - 100	Beam shaper left → right
		Frost	
8	0 - 255	0 - 100	Zoom
			Wide → narrow
9 (Mode 2 only)	0 - 2	0 - 1	Speed
	3 - 245	1 - 96	Tracking
	246 - 248	96 - 97	Fast → slow
	249 - 251	98 - 98	Tracking, no shortcuts (overrides the effects shortcut setting in the fixture settings)
	252 - 255	99 - 100	Tracking, shortcuts on (overrides the effects shortcut setting in the fixture settings)
		Dimmer, CMY, and zoom: fast (no blackout); color wheel and beam shaper: blackout while moving	

SECTION 4. SERVICE AND TROUBLESHOOTING

This section contains the following chapters:

- “Seal maintenance” on page 58
- “Cleaning” on page 60
- “Firmware updates” on page 61
- “Lamp maintenance” on page 64
- “Maintaining the electrical system” on page 69
- “Troubleshooting” on page 75

Seal maintenance

The Exterior 600 has an IP rating of 65: it is protected against dust and can withstand low pressure water jets. To maintain protection against dust and water:

- Replace any seal that becomes brittle or shows visible signs of wear.
- Verify that seals are flush with, or protrude slightly above, the surface of the aluminum covers.
- Verify that cable pass-through fittings are tightened both to the casing and the cable.
- Tighten the end plates and the lamp access plate with a torque of 3 N.m (2.2 Ft-Lbs). With this torque, the seals will be compressed by about one-third.
- When replacing the front cover, to avoid breaking the glass, tighten the screws by working around in a circle.

Two water and oil-repellent GORE-TEX membrane air vents in the rear cover of the Exterior 600 allow air to pass through the housing. This equalizes pressure differences and eliminates the potential for vacuum that can suck moisture into the fixture if it is improperly installed or maintained.

Gaskets

To maintain the fixture's resistance to dust and moisture, it is important that you replace gaskets carefully after removal. The silicone gaskets should maintain their sealing ability for the life of the fixture. When servicing the fixture, note the condition of the gaskets and replace any gasket that is cracked, torn, brittle, or inflexible. Replacement gaskets may be ordered from your Martin Architectural dealer.

The gaskets shall extend 0.5 - 1 mm (1/64 - 1/32 in.) beyond the outside of the casing. If you can feel the gasket when you run a finger across the joint, that's enough. There won't be any problem either if the gaskets are flush with the casing, but if they are below the casing's edge, they can collapse into the unit and let water in.

The recommended procedure for closing each of the 4 openings is the same.

1. Insert the screws through all holes in the cover and gasket.
2. Place the cover firmly against the body. Adjust the straight sides of the gasket so that they stick out a little bit, just enough so that you can feel it when you run a finger across the joint.
3. Cross-tighten the cover bolts. The correct torque for these bolts is 2.5 - 3.0 N.m (1.8 - 2.2 Ft-Lbs).

Cable glands

The supplied cables enter the fixture through cable glands that fit 5.5-10 mm (1/4 - 2/5 in.) diameter cables. The gland must be replaced if the power or data cable is replaced with a cable of a different diameter (larger than 10 mm or smaller than 5.5 mm (1/4 - 2/5 in.)), or if the data cable is replaced with two separate cables. Replacement glands, available from electrical suppliers, must have the following characteristics:

Temperature range	20 to 70 degrees Celsius (or better)
Ingress protection rating	IP 67 or 68
Entry thread size	PG 11
Minimum entry thread length	8 mm

Cleaning

Cleaning lenses

Clean the optical components carefully.

Remove smoke and other residues with cotton swabs or unscented tissues moistened with isopropyl alcohol. A commercial glass cleaner may be used, but residues must be removed with distilled water. Clean with a slow circular motion from center to edge. Dry with a clean, soft and lint-free cloth or compressed air.

Remove stuck particles with an unscented tissue or cotton swab moistened with glass cleaner or distilled water. Do not rub the surface: lift the particles off with a soft repeated press.

Cleaning the housing

The Exterior 600's aluminum housing can be cleaned with mild detergents such as those for washing cars.

Disconnect the fixture and allow it to cool.

Visually check that the seals are in good condition.

Rinse off loose dirt with a garden hose or low pressure water spray.

Wash the aluminum using a mild detergent and a soft brush or sponge. Do not use abrasive cleaners.

Rinse.

Firmware updates

The latest Exterior 600 firmware is available from the support area of the Martin web site at <http://www.martin.com>. It can be installed using an MP-2, or via a PC serial data link using a hardware interface supported by the Software Uploader shareware (also available from the Martin web site). The following devices are currently supported (in Version 5.5):

- DABS1
- ShowDesigner PCI DMX Interface Card (2048 channel version)
- LightJockey PCI DMX Interface Card (512 and 2048 channel versions)
- LightJockey PCMCIA DMX Interface
- LightJockey 4064 ISA DMX Interface Card (DJ and Club versions)

Note: *If you are using an intermediate control system such as the Martin Lighting Director (MLD) and the Martin Matrix, this must be bypassed when updating fixture software via the DMX link. These systems do not relay the update code correctly because it is not a DMX-compliant signal.*

When updating firmware, be sure to read the release notes to familiarize yourself with any changes in functionality or any special instructions.

Note: *Some firmware releases may require a boot mode upload, or a boot sector update. In order to prepare the Exterior 600 for this, a jumper inside the fixture must be set. In these cases, follow the procedure in “When the fixture is not responding (boot mode & boot sector upload)” on page 62.*

Normal updates (DMX/Auto mode upload)

To update fixture software, connect an upload device to the fixture just like a DMX controller and perform a DMX mode upload as described in the uploader’s documentation. There is no need to isolate the Exterior 600s from other types of fixtures on the serial link.

When the upload is completed (and when booting up) the Exterior 600 performs a check-sum test of the memory and then resets.

In the unlikely event that a software upload is interrupted, the fixture must be powered off for at least 10 seconds to force a check-sum test. You can then repeat the DMX-mode upload. If an error occurs and the fixtures do not reset, data was interrupted or corrupted during transmission.

When the normal method fails (boot mode upload)

If an upload attempt is interrupted or corrupted, the fixture must be powered off for at least 10 seconds before a second upload can be attempted. When the fixture is powered on, the LEDs will blink yellow in preparation for the second upload attempt. Perform a *boot-mode* upload (as described in the uploader documentation).

When the fixture is not responding (boot mode & boot sector upload)

If all else fails, the fixture is responding erratically or not at all, or when the software update notes call for a boot sector update or boot mode upload:

1. Make sure the Exterior 600 is isolated from AC power and has been allowed to cool for at least 20 minutes.
2. Open the fixture by removing the ten 4mm Allen screws from the rear cover plate.
3. Pull off the plate and seal.
4. To remove the printed circuit board from the fixture, remove the two Philips screws from the aluminum bracket and pull the board out.
5. On the circuit board, locate jumper PL121 (illustrated in “PCB layout” on page 78) and move the jumper to pins 1 and 2 as shown here. This will remove the write protection from the boot sector and place the fixture in boot mode where it waits to receive new firmware.
6. Replace the PCB and apply power to the fixture.
7. Perform a boot mode upload as described in the uploader documentation.

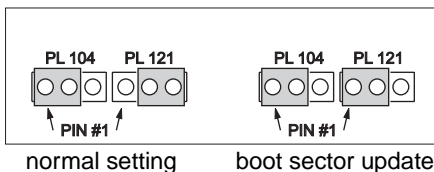

8. When the upload is complete, disconnect the fixture from power and allow to cool.
9. Remove 2 screws from the aluminum bracket and pull the PCB out.
10. Move the jumper at PL121 back to the “normal” position (pins 2 and 3).
11. Replace the PCB.
12. Before closing, check the condition of the seal. Replace with a new one (P/N 20600020) if the seal is torn, cracked or brittle.
13. To close, insert the Allen screws through all holes in the cover and seal. Place the cover firmly against the body. Adjust the straight sides of the seal so that they stick out a little bit, just enough so that you can feel the seal when you run a finger across the joint.
14. Cross-tighten the cover screws with a torque of 3 N.m (2.2 Ft-Lbs). With this torque, the seal will be compressed by about one-third.

Lamp maintenance

This chapter describes how to install and adjust a lamp. It contains the following sections:

- “Compatible lamps”
- “Maximum lamp usage”
- “Installing the lamp” on page 66

Compatible lamps

The Exterior 600 is designed to use the lamps listed below. *Installing other lamps may damage the fixture.*

Lamp	Average life	Replace by	Color temp.	Output
Philips MSD 575	3000 hours	3200 hours	6000K	78 lm/w
Philips MSR 575/2	1000 hours	1200 hours	7200K	85 lm/w
Osram HSR 575/2	1000 hours	1200 hours	6000K	85 lm/w
Osram HSD 575	3000 hours	3600 hours	7200K	78 lm/w

Note: *This data is subject to change. Refer to the manufacturer supplied specification for up-to-date information.*

Maximum lamp usage

The quartz bulb weakens over time, significantly increasing the risk of lamp explosion. Replace the lamp no later than indicated in the table above. We recommend that you replace all the lamps in an installation together. This will simplify keeping track of when you need to change the lamps in installations with many fixtures.

Resetting or checking the lamp hours counter using MUM

The Exterior 600 has a built counter that you can check or reset using the MUM application on a personal computer. When you install a new lamp we recommend that you reset the fixtures "Total lamp hours" counter.

Support for the MUM application is available from Version 2 of the Exterior 600 software.

To get started:

1. Connect a DABS1 adaptor to your PC.
2. Connect the DABS1 adaptor to your Exterior 600.
3. Power on the Exterior 600 and start the MUM application. The application will automatically detect an Exterior 600 if it is powered-on and connected to your computer via a DABS1 adaptor. It will also retrieve the current settings on the fixture and display them.
4. Using MUM, click on the **Fixture information** button:

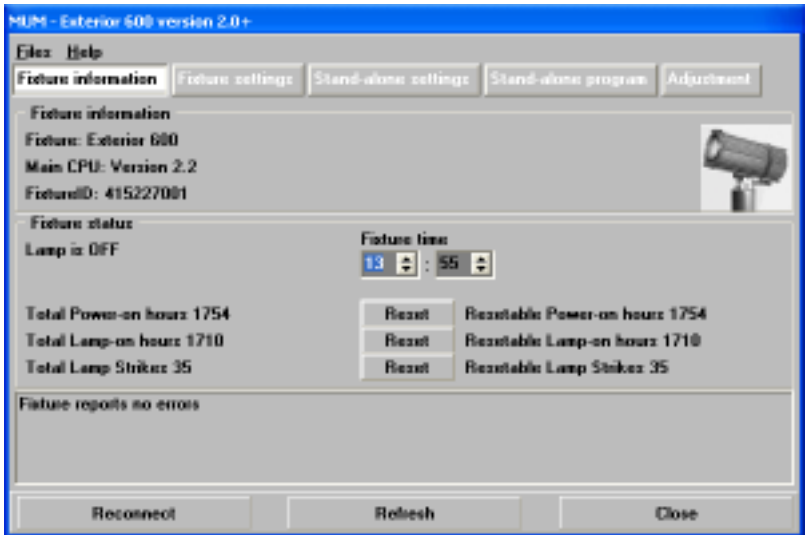

5. The **Total Lamp-on hours** will be displayed and can be reset using the button to the right of the field.

Installing the lamp

WARNING! Always disconnect the fixture from AC power and allow it to cool for 20 minutes before installing the lamp.

1. Isolate the fixture from AC power. If it is hot, allow it to cool for at least 20 minutes before proceeding. The lamp is under high pressure when hot and can explode: use safety goggles to protect your eyes.
2. Remove the nut from the M10 nut at the top of the fixture and remove the bolt.

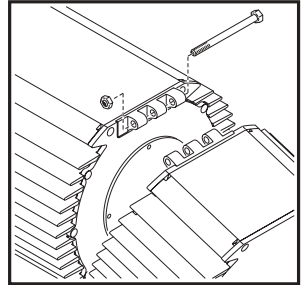

3. Loosen the bottom bolt slightly, if necessary, and tilt the rear section back no more than 45° to avoid damaging the electrical conduit beneath the fixture.

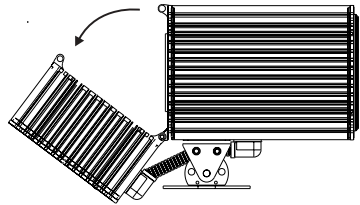

4. Remove the four 5mm Allen screws from the lamp access plate. Remove the access plate and the rubber seal.

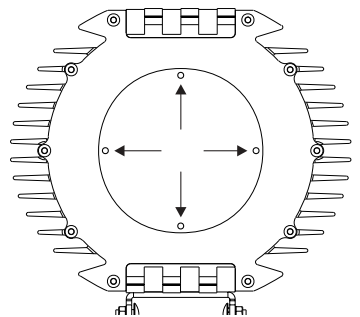

5. Remove the 2 Phillips screws from the lamp-socket assembly. Gently pull out the assembly.

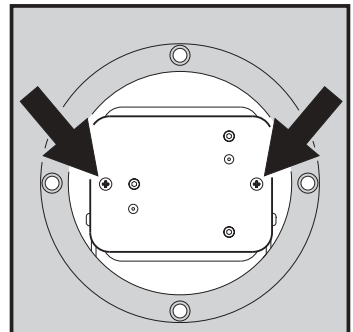

6. Remove the old lamp from the socket.
7. Holding the new lamp by its ceramic base - *do not touch the glass* - insert it firmly and squarely into the lamp socket.
8. Clean the glass bulb with the wipe supplied with the lamp, particularly if your fingers touched the glass. A clean, lint-free cloth wetted with alcohol may also be used.

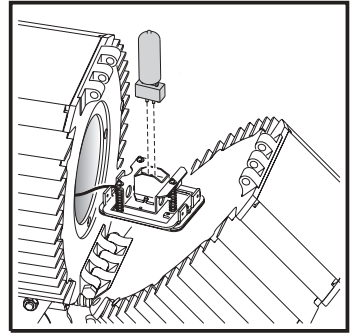

9. Re-insert the lamp assembly. Replace the 2 Phillips screws.
10. The lamp holder is adjusted at the factory; but precise alignment may be necessary due to slight variations between lamps:

- a. Apply power to the fixture.
- b. Center the hot-spot (the brightest part of the beam) by turning the 3 Allen/hex screws one at a time to move the hot-spot diagonally across the beam. If there is no hot-spot, adjust until the light is even.

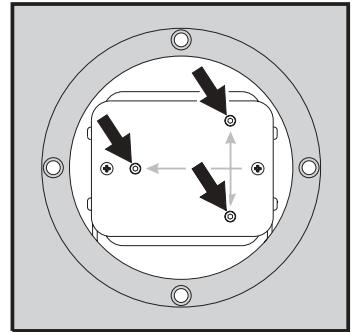

- c. To reduce the hot-spot, pull the lamp back towards you by turning all three Allen screws clockwise 1/4-turn at a time until the light is evenly distributed.
- d. If the light is brighter around the edge than it is in the center, or if light output is low, the lamp is too far back in the reflector. Move the lamp forward by turning the adjustments screws counterclockwise 1/4-turn at a time until the light is bright and evenly distributed.
- e. Disconnect the fixture from power and allow to cool.

11. Check the condition of the lamp access seal. Replace with a new one (P/N 20620050) if the seal is torn, cracked or brittle.
12. Place the seal on the back of the lamp access plate. Insert the 4 Allen screws through the plate and install. Tighten the Allen screws with a torque of 3 N.m (2.2 Ft-Lbs). With this torque, the seal will be compressed by about one-third.
13. Tilt the rear section into position and replace the long bolt and lock nut.

14. Reset the lamp-hours counter using a MUM or MP-2 Uploader. See “Resetting or checking the lamp hours counter using MUM” on page 65.

Maintaining the electrical system

This section describes electrical maintenance procedures that can be performed by the user. It contains the following sections:

- “Replacing fuses”, below
- “Changing the power settings” on page 71
- “Installing a cord cap on the mains lead” on page 17

Refer all service not described here to a qualified Martin technician.

Warning! *Disconnect the fixture from power before removing any cover.*

Always disconnect the fixture from AC power and allow it to cool for 20 minutes before servicing.

Replacing fuses

The Exterior 600 has 4 fuses; a mains fuse - 6.3 AT (Martin P/N 05020020) - and three fuses on the PCB, one for each of the fixture’s low-voltage power supplies:

- 5 AT (Martin P/N 05020018), at position F601 on the PCB
- 4 AT 5X20 (Martin P/N 05020016), at position F602 on the PCB
- 0.315 AT (Martin P/N 05020004), at position F603 on the PCB

The locations of the fuses on the PCB are illustrated in “PCB layout” on page 78.

Mains fuse

To replace the mains fuse:

1. Make sure the Exterior 600 is isolated from AC power and has cooled for at least 20 minutes.
2. Remove the ten 4mm Allen screws from the rear cover plate. Pull off the plate and seal.
3. The main fuse is located in a fuse holder inside the electronics section, to the left of the ballast. Using a flathead screwdriver, open the fuse holder and remove the fuse.
4. Replace the defective fuse with one of the same size and rating. Replace the fuse holder.
5. Before closing, check the condition of the seal. Replace with a new one (P/N 20600020) if the seal is torn, cracked or brittle.
6. To close, insert the Allen screws through all holes in the cover and seal. Place the cover firmly against the body. Adjust the straight sides of the seal so that they stick out a little bit, just enough so that you can feel the seal when you run a finger across the joint.
7. Cross-tighten the cover screws with a torque of 3 N.m (2.2 Ft-Lbs). With this torque, the seal will be compressed by about one-third.

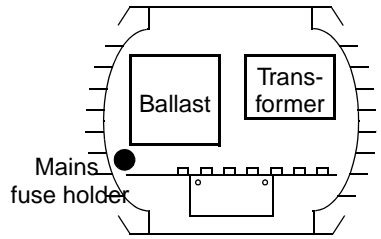

Fuses on the PCB

To replace any of the fuses on the PCB:

1. Make sure the Exterior 600 is isolated from AC power and has cooled for at least 20 minutes.
2. To open the fixture, remove the ten 4mm Allen screws from the rear cover plate. Pull off the plate and seal.
3. To remove the printed circuit board from the fixture, remove the 2 Philips screws from the aluminum bracket and pull the board out.
4. You will find a diagram of the PCB, that includes the fuses, in "PCB layout" on page 78. Locate and replace the defective fuse with one of the same size and rating.
5. Replace the PCB.
6. Before closing, check the condition of the seal. Replace with a new one (P/N 20600020) if the seal is torn, cracked or brittle.
7. To close, insert the Allen screws through all holes in the cover and seal. Place the cover firmly against the body. Adjust the straight sides of the

seal so that they stick out a little bit, just enough so that you can feel the seal when you run a finger across the joint.

8. Cross-tighten the cover screws with a torque of 3 N.m (2.2 Ft-Lbs). With this torque, the seal will be compressed by about one-third.

Changing the power settings

Warning! *The voltage and frequency settings must match the local AC power supply!*

The factory-set power supply tapplings are printed on the serial number label on the back plate. Operating at the incorrect power setting can result in poor light output, greatly reduced lamp life, overheating and damage to the fixture. If the setting does not match your local AC voltage and frequency, then the power supply must be retapped as described in:

- “Adjusting power (on models other than 277 volts)” below, or
- “Adjusting power on 277 volt models” on page 72.

Warning! *The fixture’s power supply must be rewired by a qualified installer or technician.*

Adjusting power (on models other than 277 volts)

This procedure applies to all models *except* those factory wired for 277 V supply (see the serial number label on the fixture). If the Exterior 600 model is factory wired for 277 volt supply then see “Adjusting power on 277 volt models” on page 72.

Local AC Supply		Transformer		Ballast	
Frequency	Voltage	Setting	Terminal	Setting	Terminal
50 Hz	200-210 V	210 V	4	200 V / 50 Hz	7
	210-220 V	210 V	4	230 V / 50 Hz	10
	220-235 V	230 V	6	230 V / 50 Hz	10
	235-240 V	230 V	6	245 V / 50 Hz	12
	240-260 V	250 V	8	245 V / 50 Hz	12
60 HZ	200-217 V	210 V	4	208 V / 60 Hz	4
	217-240 V	230 V	6	227 V / 60 Hz	7

Warning! Disconnect the fixture from AC power before removing any cover.

1. Make sure the Exterior 600 is isolated from AC power and has cooled for at least 20 minutes.
2. Remove the 10 Allen screws from the rear cover plate. Pull off the plate and seal.
3. Find the row in the above table with the local AC frequency and voltage. Follow the row to the right to find the correct transformer and ballast tapplings. For example, with a local AC supply of 230V, 50 Hz, the correct transformer tapping is terminal 6 and the correct ballast tapping is terminal 10.
4. To tap the transformer, move the 2 BROWN wires to the correct terminal. Terminals are identified on the transformer in front of the connection tabs.
5. To tap the ballast, move the single BROWN wire to the correct terminal.
6. Check the condition of the seal. Replace with a new one (P/N 20600020) if the seal is torn, cracked or brittle.
7. Insert the Allen screws through all holes in the cover and seal. Place the cover firmly against the body.
8. Adjust the straight sides of the seal so that they stick out a little bit, just enough so that you can feel the seal when you run a finger across the joint.
9. Cross-tighten the cover bolts. The correct torque for these bolts is 3 N.m (2.2 Ft-Lbs). With this torque, the seal will be compressed by about one-third.

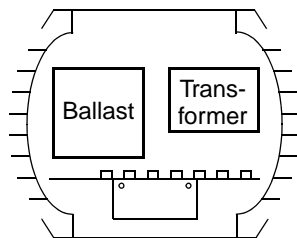

Adjusting power on 277 volt models

This procedure only applies to models factory wired for 277 V supply (see the serial number label on the fixture). If the Exterior 600 model is factory wired for another mains supply then see "Adjusting power (on models other than 277 volts)" on page 71.

1. Make sure the Exterior 600 is isolated from AC power and has cooled for at least 20 minutes.
2. To open the fixture, remove the 10 Allen screws from the rear cover plate. Pull off the plate and seal.
3. Locate the BROWN wire that connects the mains filter to the transformer.

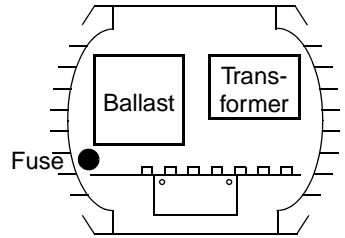

Move this wire to the transformer terminal labelled for the desired setting, 230 or 277 V. *Do not move the brown wire that leads to the ballast.*

Local AC		Transformer		Ballast	
Frequency	Voltage	Setting	Terminal	Setting	Terminal
50 Hz	218-241 V	230 V	see label	230 V / 50 Hz	10
	265-290 V	277 V	see label		
60 Hz	218-241 V	230 V	see label	227 V / 60 Hz	7
	265-290 V	277 V	see label		

4. To tap the ballast, move the single BROWN wire to terminal 7 for 60 Hz operation, or to terminal 10 for 50 Hz operation.
5. Before closing, check the condition of the seal. Replace with a new one (P/N 20600020) if the seal is torn, cracked or brittle.
6. To close, insert the Allen screws through all holes in the cover and seal. Place the cover firmly against the body. Adjust the straight sides of the seal so that they stick out a little bit, just enough so that you can feel the seal when you run a finger across the joint.
7. Cross-tighten the cover bolts with a torque of 3 N.m (2.2 Ft-Lbs). With this torque, the seal will be compressed by about one-third.

Installing a battery on the PCB

The Exterior 600's built-in clock, which can be used to start and stop operation in stand-alone mode, requires a 3V battery (P/N 05801001) on the PCB in order to keep time when the fixture is powered off.

The battery mounts on the circuit board at position BAT101, which is located right behind the sensor inputs at PL251 and PL252, on top of IC124. The position is indicated by a ring of the same size as the battery. The positive pole is indicated on the print and is the position closest to the relay.

To:

- Install the battery, heat the existing solder on the bottom of the circuit board and insert the pins from the top, one at a time.
- Prevent accidental discharge when storing in an antistatic bag, we recommend placing a drop of silicone over the solder connections.

Troubleshooting

Problem	Probable cause(s)	Remedy
One or more of the fixtures is completely dead.	Fixture not powered on.	Check that power is switched on and cables are plugged in.
	Primary fuse blown (located besides the ballast).	Disconnect fixture and replace fuse.
	Secondary fuse(s) blown (located on PCB inside the fixture base).	Disconnect fixture. Check fuses on PCB and replace.
Fixtures reset correctly but all respond erratically or not at all to the controller.	The controller is disconnected from the data link.	Connect controller.
	XLR pin-out of the controller does not match pin-out of the first fixture on the link (signal is reversed).	Install a phase-reversing cable between the controller and the first fixture on the link.
Fixtures reset correctly but some respond erratically or not at all to the controller.	Bad data link connection	Inspect connections and cables. Correct poor connections. Repair or replace damaged cables.
	Data link not terminated with 120Ω termination plug.	Insert termination plug in output jack of the last fixture on the link.
	Incorrect addressing of the fixtures.	Check fixture address and protocol settings.
	One of the fixtures is defective and disturbs data transmission on the link.	Bypass one fixture at a time until normal operation is regained. Have the defective fixture serviced by a qualified technician.
	XLR pin-out on fixtures does not match (pins 2 and 3 reversed).	Install a phase-reversing cable between the fixtures.

Problem	Probable cause(s)	Remedy
Lamp does not strike.	The ballast and transformer settings do not match local AC voltage and frequency.	Disconnect fixture. Check ballast and transformer settings and correct if necessary.
	Lamp missing or blown	Install new lamp.
	Lamp is too hot.	Allow lamp to cool for at least 8 minutes.
Lamp cuts out intermittently.	Fixture is too hot.	Allow fixture to cool.
	The ballast and transformer settings do not match local AC voltage and frequency.	Disconnect fixture. Check ballast and transformer settings and correct if necessary.
	Defective fan.	Refer to service technician.

SECTION 5. REFERENCE

This section contains the following chapters:

- “PCB layout” on page 78
- “Specifications” on page 79

PCB layout

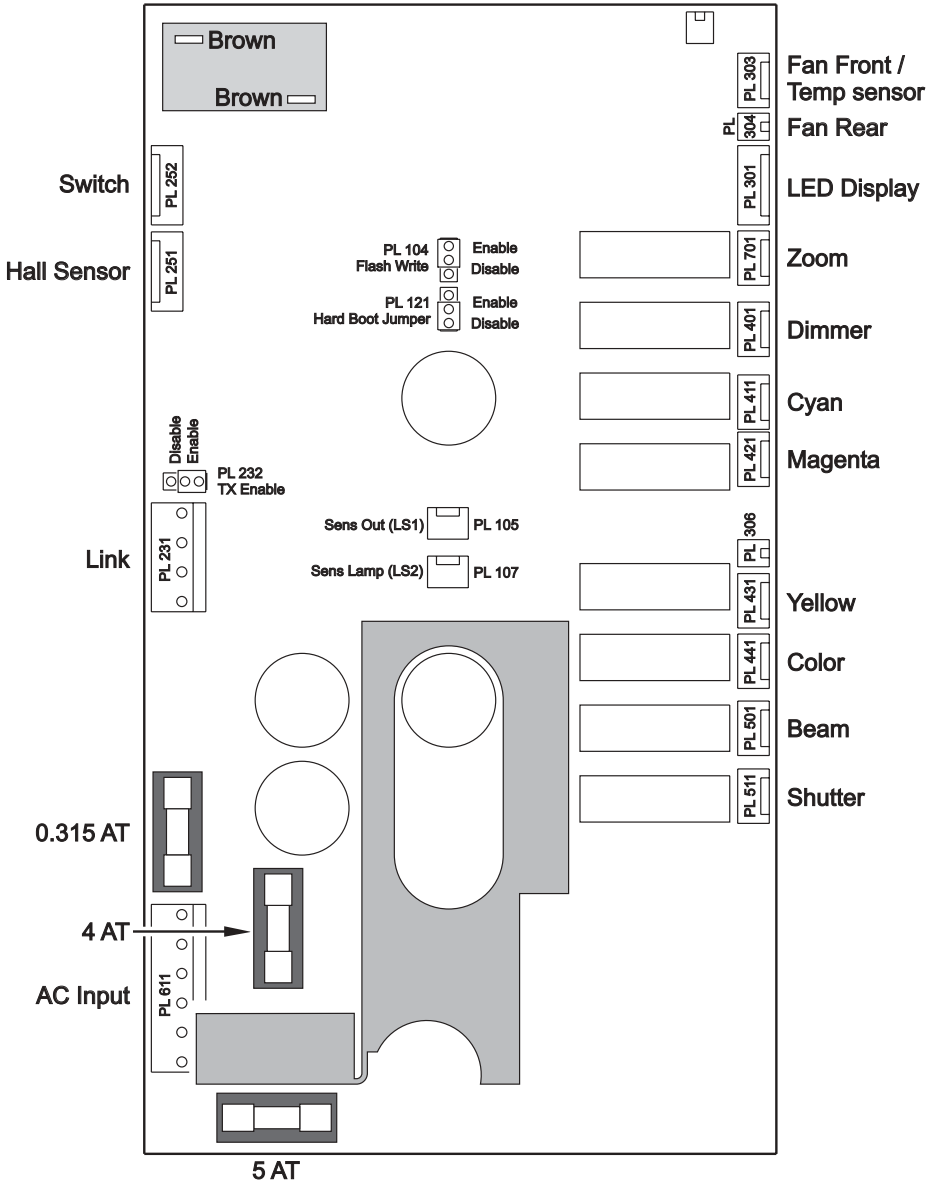

Specifications

Physical

Length.....	636 mm (25 in.)
Width.....	375 mm (14.8 in.)
Height.....	421 mm (16.6 in.)
Weight.....	48 kg (106 lb)

Source

Lamp.....	575 W discharge
Base.....	GX 9.5
Approved models.....	Philips MSR 575/2
.....	Philips MSD 575
.....	Osram HSR 575/2
.....	Osram HSD 575
Control.....	automatic and/or remote on/off

Dynamic effects

Cyan filter.....	0 - 100%
Magenta filter.....	0 - 100%
Yellow filter.....	0 - 100%
Color wheel.....	4 filters + open, split positions
Dimmer.....	0 - 100%
Shutter.....	flash up to 8 Hz (available with DMX control only)
Beam shaper ... flat, wide beam that rotates 0 - 90° (available with DMX control only)	
Frost.....	on/off
Motorized zoom.....	used on models designated 22°-38° and 18°-25°

Control & Programming

Control options.....	DMX-512, stand-alone, master/slave
Receiver.....	RS-485
Setting and addressing.....	MP-2, DAD, MUM
Firmware update.....	Serial upload (MUF)
Stand-alone triggers.....	internal real-time clock with timer and light-level sensor
Stand-alone memory.....	20 scenes
Data in/out.....	1.8 m (5.9 ft) trailing cable w/ 3-pin XLR male & 3-pin XLR female
DMX channels.....	8/9

Installation

Mounting points.....	4 curved 10 mm (0.4 in) slots on 85 mm (3.4 in) radius
Orientation.....	any
Swivel.....	+/- 25°
Tilt (pedestal mounted).....	+/- 40°
Minimum distance to combustible materials.....	1 m (39 in)
Minimum distance to illuminated surfaces.....	1 m (39 in)

Thermal

Maximum ambient temperature (Ta)	40° C (104° F)
Maximum surface temperature	90° C (194° F)
Cooling	convection

Average power consumption

@ 200 V, 50 Hz	640 W, 4.0 A
@ 230 V, 50 Hz	670 W, 3.6 A
@ 245 V, 50 Hz	660 W, 3.4 A
@ 208 V, 60 Hz	640 W, 4.0 A
@ 227 V, 60 Hz	670 W, 3.6 A

Average heat dissipation

@ 200 V, 50 Hz	2183 BTU/hour
@ 230 V, 50 Hz	2286 BTU/hour
@ 245 V, 50 Hz	2252 BTU/hour
@ 208 V, 60 Hz	2183 BTU/hour
@ 227 V, 60 Hz	2286 BTU/hour

Note: Data extrapolated from average power consumption

AC Supply

AC input	1.8 m (5.9 ft) trailing cable (without cord cap)
Operating range - 277 V model.....	218-290V/50-60Hz
Operating range - all other models.....	200-250V/50Hz & 200-240V/60Hz

Construction

Housing	extruded aluminum
Finish.....	anodized, natural aluminum color
Base	6 mm (0.24 in) stainless steel
Front glass	6 mm (0.24 in) anti-reflection coated (except 12° and 100° versions)
Protection factor	IP 65

Listings

ETL, ETL, CE

Included items

User manual.....	P/N 35000020
Philips MSD575	P/N 97010205

Accessories

Snoot/barn door kit	P/N 91611029
Extensions to snoot/barn door kit	P/N 91611030
5500-4200K CTC kit	P/N 91611036
Beam shaper 20° x 77° (only for Exterior 600, 12° models)	P/N 91610028
DMX Address Device (DAD)	P/N 90758430
Multi Utility Manager (MUM)	P/N 90758090
MP-2 Uploader	P/N 90758420
Philips MSD 575	P/N 97010202
Philips MSR 575/2	P/N 97010201
Osram HSR 575/2	P/N 97010200
Osram HSD 575	P/N 97010207
Sealing kit	P/N 91611017
Lamp replacement kit	P/N 91611018
Lamp access seal	P/N 20620050
6.3 AT mains fuse	P/N 05020020
5 AT fuse (PCB position F601)	P/N 05020018
4 AT 5X20 fuse (PCB position F602)	P/N 05020016
0.315 AT fuse (PCB position F603)	P/N 05020004

Ordering information

Exterior 600, 12°, 230V / 50Hz	P/N 90505020
Exterior 600, 12°, 245V / 50Hz	P/N 90505022
Exterior 600, 12°, 208V / 60Hz	P/N 90505024
Exterior 600, 12°, 277V / 60Hz	P/N 90505026
Exterior 600, 18-25°, 230V / 50Hz	P/N 90505040
Exterior 600, 18-25°, 245V / 50Hz	P/N 90505042
Exterior 600, 18-25°, 208V / 60Hz	P/N 90505044
Exterior 600, 18-25°, 277V / 60Hz	P/N 90505046
Exterior 600, 22-38°, 230V / 50Hz	P/N 90505000
Exterior 600, 22-38°, 245V / 50Hz	P/N 90505002
Exterior 600, 22-38°, 208V / 60Hz	P/N 90505004
Exterior 600, 22-38°, 277V / 60Hz	P/N 90505006
Exterior 600, 65°, 230V / 50Hz	P/N 90505060
Exterior 600, 65°, 245V / 50Hz	P/N 90505062
Exterior 600, 65°, 208V / 60Hz	P/N 90505064
Exterior 600, 65°, 277V / 60Hz	P/N 90505066
Exterior 600, 100°, 230V / 50Hz	P/N 90505080
Exterior 600, 100°, 245V / 50Hz	P/N 90505082
Exterior 600, 100°, 208V / 60Hz	P/N 90505084
Exterior 600, 100°, 277V / 60Hz	P/N 90505086

