



# User's Manual

## **Purifier<sup>®</sup> Delta<sup>™</sup> Series** **Class II, Type B2 Total Exhaust** **Biological Safety Cabinets**

### **Models**

**36210 Series**

**36214 Series**



Labconco's Mascot,  
Labby the LABster



*Protecting your  
laboratory environment*

**LABCONCO<sup>®</sup>**

For more information, please contact us:

[ExpotechUSA](#)  
[10700 Rockley Road](#)  
[Houston, Texas 77099](#)  
[USA](#)

[281-496-0900 \[voice\]](#)

[281-496-0400 \[fax\]](#)

E-mail: [sales@expotechusa.com](mailto:sales@expotechusa.com)

Website: [www.ExpotechUSA.com](http://www.ExpotechUSA.com)

## **Warranty**

Labconco provides a warranty on all parts and factory workmanship. The warranty includes areas of defective material and workmanship, provided such defect results from normal and proper use of the equipment.

The warranty for all Labconco products will expire one year from date of installation or two years from date of shipment from Labconco, whichever is sooner, except the following:

- Purifier® Delta® Series Biological Safety Cabinets carry a three-year warranty from date of installation or four years from date of shipment from Labconco, whichever is sooner.
- Carts carry a lifetime warranty.
- Glassware is not warranted from breakage when dropped or mishandled.

This limited warranty covers parts and labor, but not transportation and insurance charges. In the event of a warranty claim, contact Labconco Corporation or the dealer who sold you the product. If the cause is determined to be a manufacturing fault, the dealer or Labconco Corporation will repair or replace all defective parts to restore the unit to operation. Under no circumstances shall Labconco Corporation be liable for indirect, consequential, or special damages of any kind. This statement may be altered by a specific published amendment. No individual has authorization to alter the provisions of this warranty policy or its amendments. Lamps and filters are not covered by this warranty. Damage due to corrosion or accidental breakage is also not covered.

## **Limitation of Liability**

The disposal and/or emission of substances used in connection with this equipment may be governed by various federal, state, or local regulations. All users of this equipment are required to become familiar with any regulations that apply in the user's area concerning the dumping of waste materials in or upon water, land, or air and to comply with such regulations. Labconco Corporation is held harmless with respect to user's compliance with such regulations.

---

# TABLE OF CONTENTS

<b>CHAPTER 1: INTRODUCTION</b>	1
About This Manual	2
Typographical Conventions	3
Your Next Step	4
<b>CHAPTER 2: PREREQUISITES</b>	7
Location Requirements	8
Exhaust Requirements	8
Electrical Requirements	9
Service Line Requirements	10
Space Requirements	11
Your Next Step	11
<b>CHAPTER 3: GETTING STARTED</b>	13
Unpacking Your Biosafety Cabinet	14
Purifier Components	15
Removing the Shipping Skid	15
Installing the Purifier on an Existing Work Surface	19
Installing the Purifier on the Labconco Base Stand	20
Exhaust System Connections	23
Exhaust System Requirements	23
Connecting the Purifier to Service Lines	24
Measuring the Total Exhaust Volume	26
Measuring the Cabinet Inflow Volume	26
Calibration of the Face Velocity Alarm	27
Drain Valve Installation	27
Initial Certification	28
Your Next Step	29

<b>CHAPTER 4: THEORY OF OPERATION AND SAFETY PRECAUTIONS</b>	31
HEPA Filters	32
Laminar Airflow	33
Directional Airflow	34
Motor/Blower	35
Speed Control	36
Cabinet Air Intakes (Grilles), Ductwork & Air Balance Controls	36
Safety Precautions	37
Your Next Step	41
<b>CHAPTER 5: USING YOUR PURIFIER</b>	43
Operating the Sliding Sash	43
If The Alarm Activates	46
Resetting the Alarm	46
Working in Your Purifier	47
Safety and Comfort	49
Arranging Your Work Area	53
Your Next Step	57
<b>CHAPTER 6: MAINTAINING YOUR PURIFIER</b>	59
Routine Maintenance Schedule	59
Service Operations	60
Downflow Velocities	63
Downflow Velocity Grid Patterns	64
Air Volumes Defined	64
Measuring the Total Exhaust Volume	64
Exhaust Control System Adjustment	65
Measuring the Cabinet Inflow Volume – Primary Method	66
Inflow Velocity Calculation – Secondary Method	66
Calibration of the Face Velocity Alarm	68
Electronics Module Access	69
Measuring Line and Motor Voltage	70
Speed Control Adjustment	72
Use of the Access Tube for DOP Testing	73
HEPA Filter Replacement	74
Motor/Blower Maintenance & Replacement	78
Diffuser Removal	79
Storage	80
Decontamination	80
Your Next Step	81

<b>CHAPTER 7: MODIFYING YOUR BIOSAFETY CABINET</b>	83
Installing a UV Lamp	83
Installing Additional Service Fixtures	86
Installing the IV Bar	88
Your Next Step	89
<b>CHAPTER 8: TROUBLESHOOTING</b>	91
<b>APPENDIX A: PURIFIER COMPONENTS</b>	95
<b>APPENDIX B: BIOSAFETY CABINET DIMENSIONS</b>	97
<b>APPENDIX C: BIOSAFETY CABINET SPECIFICATIONS</b>	99
Electrical Data	99
Motor Specifications	99
<b>APPENDIX D: PURIFIER ACCESSORIES</b>	107
Safety Orange Air Foil	107
Base Stands	107
Service Valve Kit	108
Ultraviolet Lamp Kits	108
IV Bar Kits	108
Remote Blower	109
Ergonomic Chair	109
Adjustable Footrest	110
<b>APPENDIX E: QUICK CHART FOR THE DELTA                   TOTAL EXHAUST PURIFIERS</b>	111
<b>APPENDIX F: REFERENCES</b>	113
<b>DECLARATION OF CONFORMITY</b>	115

---

# CHAPTER 1

## INTRODUCTION

Congratulations on your purchase of a Labconco Purifier Delta Series Total Exhaust Biosafety Cabinet. Your Purifier is designed to protect you, your product and your laboratory environment from biohazardous aerosols. It is the result of Labconco's more than 25 years experience of manufacturing biohazard cabinetry, and many of its features were suggested to us by users like you.

The Purifier offers many unique features to enhance safety, performance and ergonomics. To take full advantage of them, please acquaint yourself with this manual and keep it handy for future reference. If you are unfamiliar with how biosafety cabinets operate, please review *Chapter 4: Theory of Operation and Safety Precautions* before you begin working in the cabinet. Even if you are an experienced biosafety cabinet user, please review *Chapter 5: Using Your Purifier*; it describes your Purifier's features so that you can use the cabinet efficiently.

## About This Manual

This manual is designed to help you learn how to install, use, and maintain your biosafety cabinet. Instructions for installing optional equipment on your cabinet are also included.

*Chapter 1: Introduction* provides a brief overview of the biosafety cabinet, explains the organization of the manual, and defines the typographical conventions used in the manual.

*Chapter 2: Prerequisites* explains what you need to do to prepare your site before you install your biosafety cabinet. Electrical and service requirements are discussed.

*Chapter 3: Getting Started* contains the information you need to properly unpack, inspect, install, and certify your biosafety cabinet.

*Chapter 4: Theory Of Operation And Safety Precautions* explains how the Purifier operates and the appropriate precautions you should take when using the cabinet.

*Chapter 5: Using Your Purifier* discusses the basic operation of your cabinet. Information on how to prepare, use and shut down your Purifier are included.

*Chapter 6: Maintaining Your Purifier* explains how to perform routine maintenance on your biosafety cabinet. Information on how to safely disinfect the interior of your cabinet and replace the lamps are included.

*Chapter 7: Modifying Your Biosafety Cabinet* describes how to install the optional equipment on the cabinet.

*Chapter 8: Troubleshooting* contains a table of problems you may encounter while using your biosafety cabinet including the probable causes of the problems and suggested corrective actions.



*Appendix A: Purifier Components* contains labeled diagrams of all of the components of the biosafety cabinets.

*Appendix B: Biosafety Cabinet Dimensions* contains comprehensive diagrams showing all of the dimensions for the 4 and 6 foot models of the biosafety cabinet.

*Appendix C: Biosafety Cabinet Specifications* contains the electrical requirements for the biosafety cabinet. Wiring diagrams for both the 115V and 230V units are also included.

*Appendix D: Purifier Accessories* lists the part number and descriptions of all of the accessories available for your biosafety cabinet.

*Appendix E: Quick Chart for the Delta Purifiers* provides useful operating specifications.

*Appendix F: References* lists the various resources available that deal with biosafety.

## Typographical Conventions

Recognizing the following typographical conventions will help you understand and use this manual:

- Book, chapter, and section titles are shown in italic type (e.g., *Chapter 3: Getting Started*).
- Steps required to perform a task are presented in a numbered format.
- Comments located in the margins provide suggestions, reminders, and references.
- Critical biosafety information is presented in boldface type in paragraphs that are preceded by the biosafety icon. Failure to comply with the information following a biosafety icon may result in illness or death.



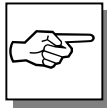
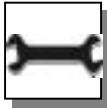

- Critical information is presented in boldface type in paragraphs that are preceded by the exclamation icon. Failure to comply with the information following an exclamation icon may result in injury to the user or permanent damage to your biosafety cabinet.
- Critical information is presented in boldface type in paragraphs that are preceded by the wrench icon. These operations should only be performed by a trained certifier or contractor. Failure to comply with the information following a wrench icon may result in injury to the user or permanent damage to your biosafety cabinet.
- Important information is presented in capitalized type in paragraphs that are preceded by the pointer icon. It is imperative that the information contained in these paragraphs be thoroughly read and understood by the user.
- Information that is specific to a particular model of Biosafety Cabinet is preceded by a number icon. The 4' icon indicates the text is specific to the 4-foot model. The 6' icon indicates the text is specific to the 6-foot model.

## Your Next Step

If your Purifier needs to be installed, proceed to *Chapter 2: Prerequisites* to ensure your installation site meets all of the requirements. Then, go to *Chapter 3: Getting Started* for instructions on how to install your biosafety cabinet and make all of the necessary connections.

If you would like to review how biosafety cabinets operate, go to *Chapter 4: Theory Of Operation And Safety Precautions*.

For information on the operational characteristics of your biosafety cabinet, go to *Chapter 5: Using Your Purifier*.

If your biosafety cabinet is installed and you need to perform routine maintenance on the cabinet, proceed to *Chapter 6: Maintaining Your Purifier*.

For information on making modifications to the configuration of your unit, go to *Chapter 7: Modifying Your Biosafety Cabinet*.

Refer to *Chapter 8: Troubleshooting* if you are experiencing problems with your Purifier.



---

# CHAPTER 2

## PREREQUISITES

Before you install your biosafety cabinet, you need to prepare your site for installation. Carefully examine the location where you intend to install your cabinet. You must be certain that the area is level and of solid construction. In addition, a dedicated source of electrical power must be located near the installation site.

Carefully read this chapter to learn:

- the location requirements for your installation site.
- the exhaust requirements for your installation site.
- the electrical power requirements for your installation site.
- the service line requirements for your installation site.
- the space requirements for your installation site.

Refer to *Appendix C: Biosafety Cabinet Specifications* for complete biosafety cabinet electrical and environmental conditions, specifications and requirements.

## Location Requirements



The Purifier should be located away from traffic patterns, doors, fans, ventilation registers, fume hoods and any other air-handling device that could disrupt its airflow patterns. All windows in the room should be closed. Figure 2-1 shows the optimum location for the Purifier.

**DO NOT** locate the cabinet on a cart, dolly, or mobile bench. **ALL** Purifier installations must be permanent and stationary.

Figure 2-1

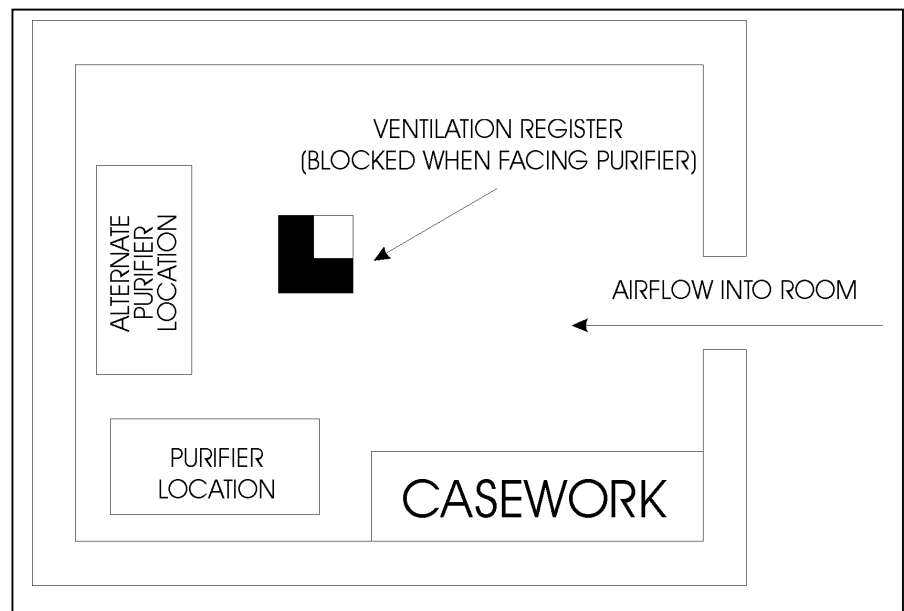

## Exhaust Requirements

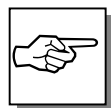

BEFORE DECIDING ON A LOCATION, EXAMINE IT CAREFULLY TO ENSURE THAT IT IS COMPATIBLE WITH THE

CABINET'S EXHAUST DUCT. THE AREA DIRECTLY ABOVE THE CABINET'S EXHAUST PORT SHOULD BE CLEAR OF STRUCTURAL ELEMENTS, WATER AND UTILITY LINES, OR OTHER FIXED OBSTRUCTIONS. THERE SHOULD BE ENOUGH CLEARANCE TO ALLOW FOR THE PASSAGE OF A 10" PVC DUCT. AVOID CABINET LOCATIONS THAT REQUIRE EITHER AN ELBOW DIRECTLY ON TOP OF THE CABINET'S EXHAUST CONNECTION OR AN EXCESSIVE NUMBER OF ELBOWS TO CLEAR OTHER ITEMS. FOR A FURTHER DISCUSSION OF THE CABINET'S EXHAUST SYSTEM REQUIREMENTS, PLEASE GO TO *Chapter 3: Getting Started*.

## Electrical Requirements

The different Purifier models have the following electrical requirements:

**Table 2-1**

Model #	Requirements
36210- 00-09	115 VAC, 60 Hz, 12 Amps
36210- 10-19	100 VAC, 50 / 60 Hz, 12 Amps
36210- 20-29	230 VAC, 50 Hz, 6 Amps
36214- 00-09	115 VAC, 60 Hz, 12 Amps
36214- 10-19	100 VAC, 50 / 60 Hz, 12 Amps

All Purifiers with model numbers ending in –00 to –09 are designed for operation at 115 volts 60Hz, alternating current. Models with numbers ending in –10 to –19 are designed for operation at 100 to 120 volts 50/60Hz. Purifiers with model numbers ending in –20 to –29 are designed for operation at 230 +/- 20 volts 50Hz alternating current. A dedicated outlet with a circuit breaker rated at 20 amps should be located as close as possible to the right rear side of the cabinet, at

a height even with, or higher than, the bottom of the cabinet in its final location. If your electrical outlet is distant from this location, contact Labconco's Product Service Department for information on longer cords.



**Always follow the plug manufacturer's instructions for the proper assembly and testing of the plug and power cord.**

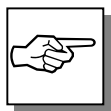

BOTH ELECTRICAL OUTLETS OF THE 100 AND 115 VOLT PURIFIER ARE PROTECTED BY A GROUND FAULT INTERRUPTER CIRCUIT (GFIC). LABCONCO DOES NOT RECOMMEND INSTALLING A GFIC ON THE OUTLET THAT THE PURIFIER PLUGS INTO.

## Service Line Requirements

All service lines to the Purifier should be ¼ inch outside diameter, metal, and equipped with an easily accessible shut-off valve, should disconnection be required. If the service line pressure exceeds 40 PSI, it must be equipped with a pressure regulator to reduce the line pressure.



**The use of flammable gases or solvents should be avoided in the Purifier. Open flames in the cabinet will disrupt the laminar airflow in the cabinet and may damage the HEPA filter. Flammable gases or solvents may reach explosive concentrations in the cabinet or ductwork. If you feel that your procedure requires the use of an open flame or flammable materials, contact the appropriate safety official.**



**The use of air or gases under high pressure should be avoided as they may seriously disrupt the airflow patterns in the cabinet.**

## Space Requirements

The dimensions for the different models are shown in *Appendix B: Biosafety Cabinet Dimensions*.

## Your Next Step

After you have determined that the location you have selected accommodates the installation and operational requirements of your biosafety cabinet, you are ready to begin installation. Proceed to *Chapter 3: Getting Started*.



---

# CHAPTER 3

## GETTING STARTED

Now that the site for your biosafety cabinet is properly prepared, you are ready to unpack, inspect, install, and certify your unit. Read this chapter to learn how to:

- unpack and move your Purifier.
- set up the cabinet.
- connect to an exhaust system.
- connect the electrical supply source.
- connect the service lines.
- arrange certification of your Purifier.

Depending upon which model you are installing, you may need common plumbing and electrical installation tools in addition to two 1/2" wrenches, a 7/16" wrench, a flat-blade screwdriver, a Phillips screwdriver, and a carpenter level to complete the instructions in the chapter.



**The Purifier models weigh between 600 – 800 lbs. (182-318 kg). The carton allows for lifting with a mechanical lift truck or floor jack. If you must lift the Purifier manually, use at least six (6) persons and follow safe-lifting guidelines.**

## Unpacking Your Biosafety Cabinet

*The United States Interstate Commerce Commission rules require that claims be filed with the delivery carrier within fifteen (15) days of delivery.*

Carefully unpack your Purifier and inspect it for damage that may have occurred in transit. If your unit is damaged, notify the delivery carrier immediately and retain the entire shipment intact for inspection by the carrier.

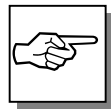

**DO NOT RETURN GOODS WITHOUT THE PRIOR AUTHORIZATION OF LABCONCO. UNAUTHORIZED RETURNS WILL NOT BE ACCEPTED.**

**IF YOUR CABINET WAS DAMAGED IN TRANSIT, YOU MUST FILE A CLAIM DIRECTLY WITH THE FREIGHT CARRIER. LABCONCO CORPORATION AND ITS DEALERS ARE NOT RESPONSIBLE FOR SHIPPING DAMAGES.**

Do not discard the carton or packing material for your Purifier until you have checked all of the components and installed and tested the unit.

Do not remove the Purifier from its shipping skid until it is ready to be placed into its final location. Move the unit by placing a flat, low dolly under the shipping skid, or by using a floor jack.



**Do not move the cabinet by tilting it onto a hand truck.**

## Purifier Components

Labconco manufactures biosafety cabinets available in 4-foot and 6-foot widths. Some models are available in 115V, 100V or 230V.

Locate the cabinet model you received in the following group of tables. Verify that the components listed are present and undamaged.

<b>Catalog #</b>	<b>Purifier Description</b>
36210-00	4 foot Purifier, 8 inch sash opening, 115 VAC
36210-04	4 foot Purifier with UV lamp & fixture, 8 inch sash opening, 115 VAC
36210-10	4 foot Purifier, 8 inch sash opening, 100 VAC 50/60 Hz
36210-14	4 foot Purifier with UV lamp and fixture, 8 inch opening, 100 VAC 50/60 Hz
36210-20	4 foot Purifier, 8 inch sash opening, 230 VAC
36210-24	4 foot Purifier with UV lamp & fixture, 8 inch sash opening, 230 VAC
36214-00	6 foot Purifier, 8 inch sash opening, 115 VAC
36214-04	6 foot Purifier with UV lamp & fixture, 8 inch sash opening, 115 VAC
36214-10	6 foot Purifier, 8 inch sash opening, 100 VAC 50/60 Hz
36214-14	6 foot Purifier with UV lamp and fixture, 8 inch opening, 100 VAC 50/60 Hz

### Plus the Following:

<b>Part #</b>	<b>Component Description</b>
37584-00	User's Manual Drain Valve Assembly Power Cord

If you did not receive one or more of the components listed for your Purifier, or if any of the components are damaged, contact Labconco Corporation immediately for further instructions.

## Removing the Shipping Skid

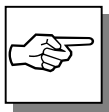

LEAVE THE PURIFIER ATTACHED TO ITS SHIPPING SKID UNTIL IT IS AS CLOSE TO ITS FINAL LOCATION AS POSSIBLE. MOVE THE UNIT BY USING A SUITABLE FLOOR JACK, OR BY PLACING A

FURNITURE DOLLY  
UNDERDNEATH THE SKID. DO  
NOT MOVE THE CABINET BY  
TILTING IT ONTO A HAND TRUCK.

After you verify the Purifier components, move your cabinet to the location where you want to install it. Then, follow the steps listed below to remove the shipping skid from your unit.

**To remove the shipping skid:**



**The side panels of the Purifier are heavy; exercise caution when removing and installing them.**

1. Remove the plastic wrapping and corner posts. Remove the packaging material from the top of the cabinet.
2. Remove both side panels by loosening and keeping the screws and 3 acorn nuts that secure each panel to the Purifier, as shown in Figure 3-2.
3. Remove and discard the four screws that secure the unit to the skid, as shown in Figure 3-1.
4. Remove the two sash retaining screws and brackets from the bottom edge of the sash. Discard the screws and brackets.

**Figure 3-1**

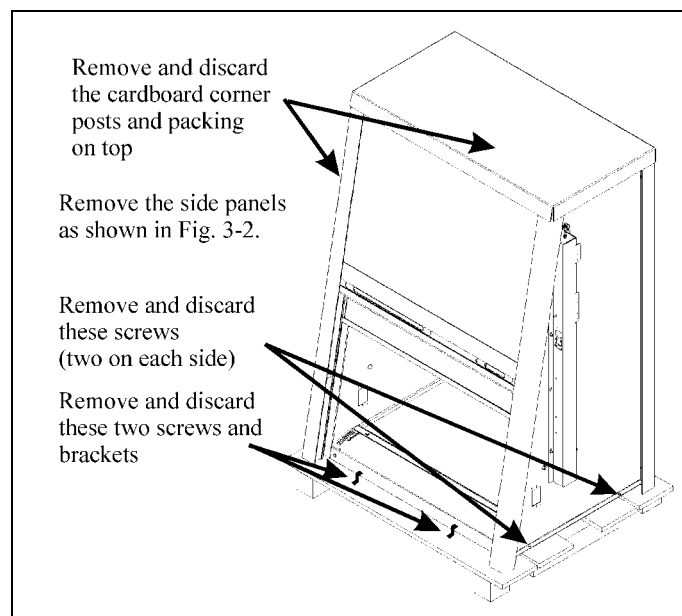
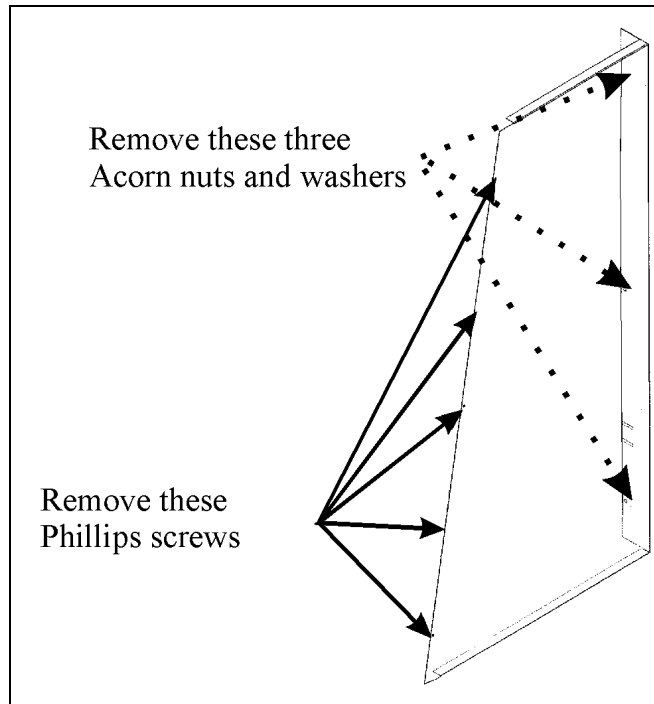

Figure 3-2



5. Examine the sash cables at both upper front corners of the Purifier, as shown in Figure 3-3. The cables should rest securely in the pulley.



**Ensure that both sash cables are properly oriented before proceeding. Releasing the sash weights with the cables improperly positioned can damage the cables, pulleys or its axle.**

6. Locate the weight restraining bolt in each weight channel. It is a ¼ inch diameter bolt that runs from the front through to the rear of the channel. Its location in the channel will vary from model to model. Remove each bolt while supporting the sash cable, ensuring that it is seated in the pulley. Save the bolts for future use if the unit is to be transported.
7. Install the two sash stop screws and spacers on the front of the cabinet, as shown in Figure 3-4.

8. Raise and lower the sash to check it for proper operation. The sash should move smoothly. If the sash binds or requires excessive force to operate, examine the cables and pulley for proper operation.
9. Examine the right weight track as shown in Figure 3-3. When the sash is completely closed and resting against the sash stop, the top surface of the weight should be  $1\frac{5}{8}$ " (41 mm) below the top of the weight channel. If it is not, adjust the weight channel by loosening the six nuts that secure the channel to the side wall of the cabinet. Slide the weight channel up or down until the dimension is proper. Retighten all six nuts to secure the channel.

Figure 3-3

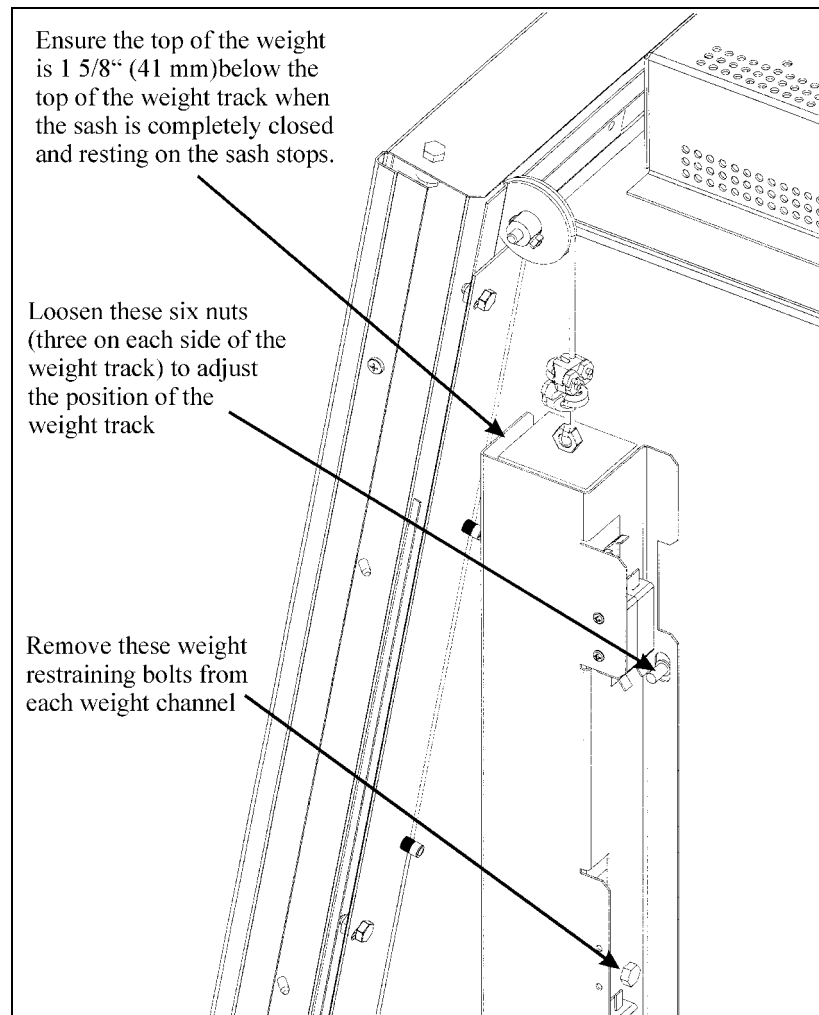
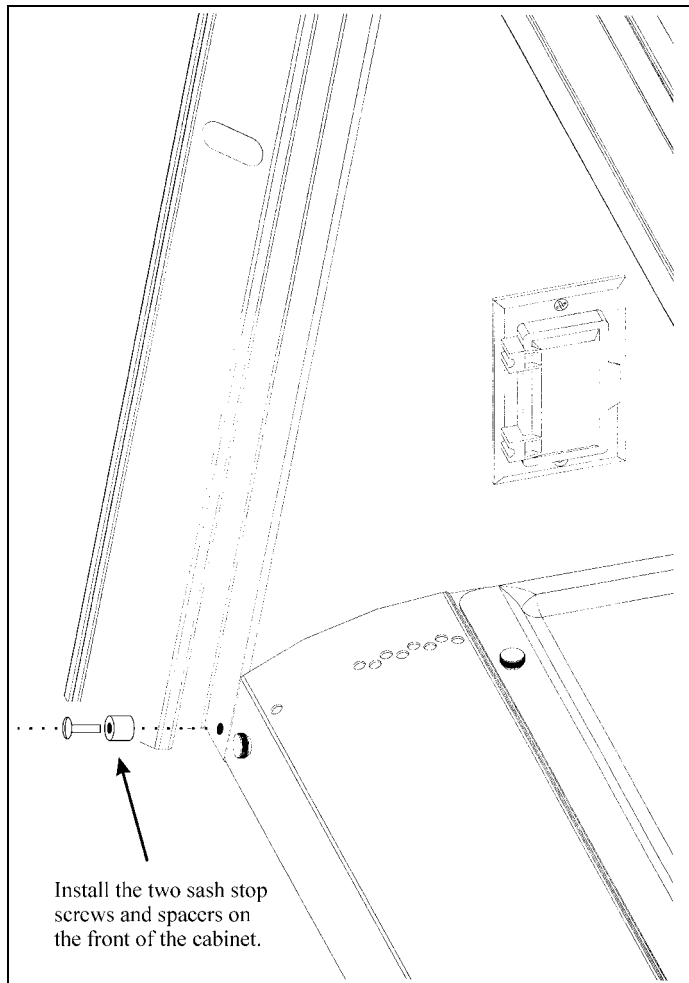



Figure 3-4



## Installing the Purifier On An Existing Work Surface



**The Purifier is very top heavy! Use caution when lifting or moving the unit.**

When installing the Purifier onto an existing work surface or benchtop, ensure that the structure can safely support the combined weight of the cabinet and any related equipment. The work surface should be at least as wide as the unit and 31 inches deep to properly support the unit.

The work surface should be smooth and durable. The surface should be nonporous and resistant to the disinfectants and chemicals used in conjunction with the Purifier. These criteria will allow a proper seal to form between the bottom of the Purifier and the work surface.

A hole or notch may need to be cut in some work surfaces in the right front corner to accommodate the drain valve.

## Installing the Purifier on the Labconco Base Stand

Labconco offers Base Stands as an option to support the Purifier, which are to be purchased separately. The stands are adjustable from a working (work surface) height of 30 inches (76.2 cm) to 36 inches (91.4 cm) in 1 inch (2.5 cm) increments. The base stand for each Purifier model is listed in Table 3-1 below.

**Table 3-1**

<b>Purifier Model #</b>	<b>Base Stand Model #</b>
36210-xx	37304-00
36214-xx	37306-00

For further information regarding Purifier Base Stands or other accessories, please contact Labconco's Customer Service Department at 1-800-821-5525 or 816-333-8811 weekdays, between the hours of 7:00 a.m. and 6:00 p.m. CST.

1. Before positioning the Purifier Base Stand in its final location, decide the final height of the stand. The working height can be anywhere between 30 to 36 inches.
2. Select the height of the stand and slide four (4) leg extensions into base stand corner posts and attach with 2 ¼ inch long bolt, flatwasher, lockwasher and nut. Ensure that the same height hole is selected for each leg. Tighten the leg bolts securely. See Figure 3-5.

**Figure 3-5**

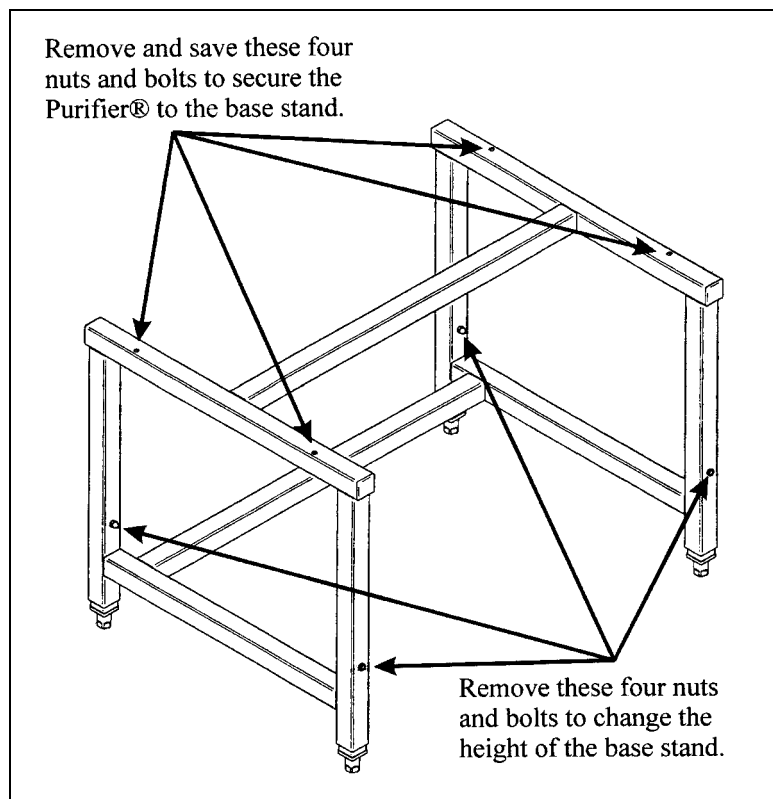

3. Move the base stand into its final location. Using a carpenter's level, adjust each leveling foot until the stand is level in both planes as shown in Figure 3-6. You are now ready to lift the Purifier onto its stand.

Figure 3-6

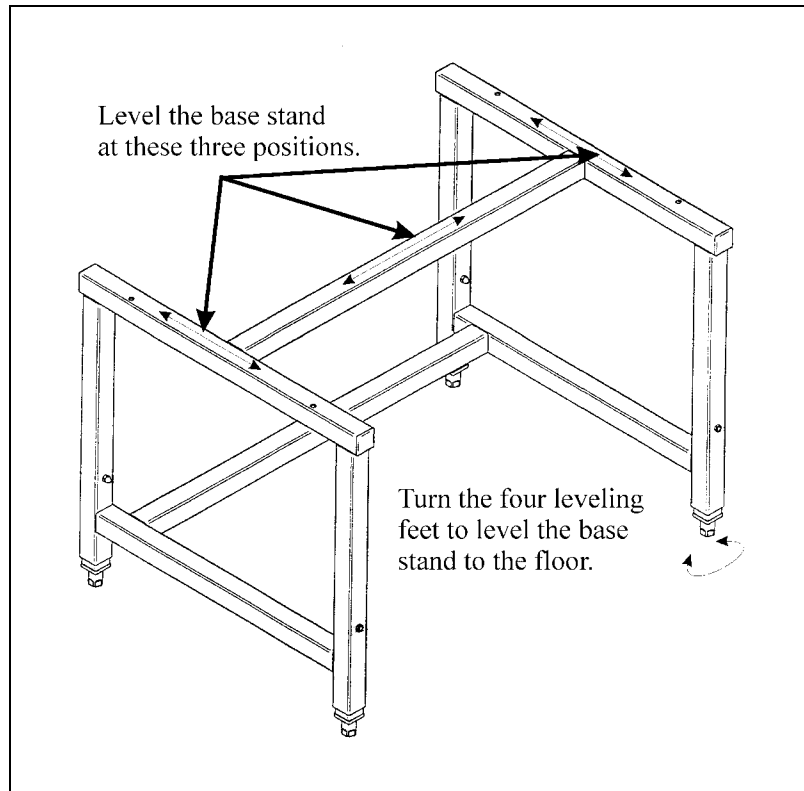

**The Purifier is very top heavy! Use caution when lifting or moving it.**

4. Carefully lift the Purifier onto the top rails of the base stand and slide it into position.
5. Using a drift punch, or a medium sized screwdriver, align one of the four holes in the bottom flange of the Purifier with its matching hole in the base stand.
6. Insert the 5/16-inch mounting bolt through the hole and secure it with a flatwasher, lockwasher and acorn nut.
7. Repeat steps 5 and 6 for the remaining bolts.
8. Tighten all four bolts securely.

## Exhaust System Connections

The Purifier Delta Series Total Exhaust Biosafety Cabinets are a “Type B2 cabinet,” meaning they direct their HEPA filtered exhaust air out of the laboratory.



**The Delta Total Exhaust Biosafety Cabinet is designed to be connected to an appropriate exhaust system. Do not attempt to operate it when it is not connected to an appropriate exhaust system.**

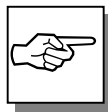

THE EXHAUST CONNECTION IS A SEALED EXHAUST SYSTEM FROM THE TOP OF THE CABINET TO THE REMOTE BLOWER. THE EXHAUST SYSTEMS SHOULD BE DEDICATED TO A SINGLE CABINET. THE CABINET IS EQUIPPED WITH AN EXHAUST FLOW ALARM, SUCH THAT AN ALARM SOUNDS, AND THE CABINET BLOWER SHUTS OFF IN THE EVENT OF INSUFFICIENT EXHAUST FLOW.

If your research involves the use of toxic compounds or volatile materials, contact your facility’s safety officer or Labconco to ensure that your Purifier and its exhaust system are compatible with the materials you will be working with.

## Exhaust System Requirements

The cabinet exhaust stack is sized to accept 10-inch PVC ductwork. The exhaust system’s blower should be sized to handle the exhaust volume of each cabinet, as shown in Table 6-1, with a static pressure equal to or

greater than the system pressure, plus 1.2 inches of water. In order to get the maximum life out of the cabinet's exhaust filter, the system needs to be able to pull a vacuum of 3.2 inches of water at the cabinet's rated flow volume.



**The exhaust system should be fitted with a backdraft damper to prevent the reversing of airflow in the system.**

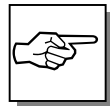

LABCONCO MANUFACTURES AN EXHAUST BLOWER WITH INTEGRAL BACKDRAFT DAMPER, PART NUMBER 36635, THAT IS SUITABLE FOR MOST SINGLE CABINET INSTALLATIONS. THE REMOTE BLOWER IS DISCUSSED FURTHER IN APPENDIX D.

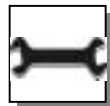

**Balancing of airflows in the cabinet is accomplished by adjustment of the cabinet's exhaust control system and speed control. The exhaust system should be considered a separate system, distinct from the Purifier. Changing the damper setting or the speed control will affect the inflow and downflow values. Both must be checked after any adjustment.**

**Downflow and inflow values and measurement procedures for the Purifier are described fully in *Chapter 6: Maintaining Your Purifier*.**

## Connecting The Purifier to Service Lines

The service lines (if any) should be connected to the tube fitting(s) on the outside of the liner wall as shown in Figure 3-7. To install the tubing, follow these steps:

1. Ensure that the tubing is  $\frac{1}{4}$  inch outside diameter, soft metal, and that the end has been deburred completely.
2. Route the tubing from the rear of the cabinet, ensuring that it will line up with the slot in the back of the side panel.



**Make sure that the tube routing will not contact any electrical wires.**

**If routing tubing to the front valve position, route the tubing under the sash weight track and at the bottom edge of the side panel. Ensure that the tubing will not interfere with the sash weight when the sash is raised or lowered.**

3. Make sure that the tube fitting nut on the fitting is loose, but do not remove it. Look inside the fitting to make sure the tube ferrule is there.
4. Push the tube into the fitting until it is properly seated. The tube will go approximately  $\frac{3}{4}$  inch into the fitting.
5. Tighten the tube fitting nut hand tight and then, using a  $\frac{7}{16}$  inch wrench, tighten it at least  $\frac{3}{4}$  turn more.
6. Close the service valve in the Purifier and then slowly open the shutoff valve on the service valve. Inspect the fitting for leakage. Tighten the tube nut slightly if needed.

Figure 3-7

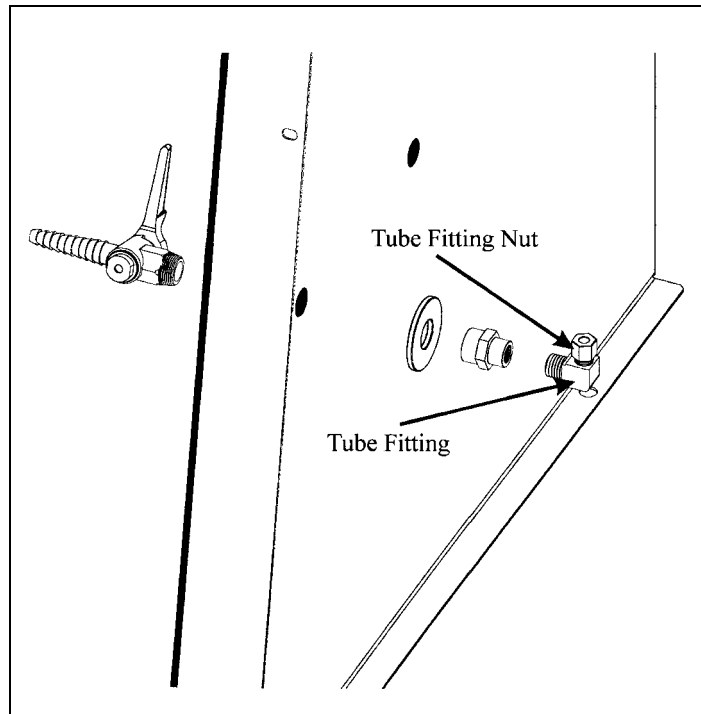

## Measuring the Total Exhaust Volume

Measuring the total exhaust volume is covered in *Chapter 6: Maintaining Your Purifier*.

## Measuring the Cabinet Inflow Volume

Measuring the cabinet inflow volume is covered in *Chapter 6: Maintaining Your Purifier*.



## Calibration of the Face Velocity Alarm

Calibration of the face velocity alarm is covered in *Chapter 6: Maintaining Your Purifier*.

## Drain Valve Installation

In order to prevent damage during shipping, the drain valve assembly has not been installed in the unit. If desired, the valve should be installed after the unit is in its final location. To install the valve assembly, follow these steps:



**The work surface is heavy. Use caution when handling it.**

**The six foot work surface is a large part. Use two people and proper lifting technique when removing it from the cabinet.**

1. Lift the work surface out of the Purifier by removing the thumbscrews at the front of the work surface and loosening those at the rear of the pan.
2. Using a putty knife, carefully remove and discard the stainless steel cover that is sealed over the drain mounting holes. Scrape any remaining sealant that is around the holes.
3. Apply a light coating of the silicone sealant to the mounting surface of the drain assembly. Attach the drain assembly as shown in Figure 3-9. Wipe off any excess sealant from the cabinet bottom. Ensure that the center drain hole is unobstructed.
4. Make sure the drain valve is in the closed position.
5. Reinstall the work surface.
6. Allow the silicone sealant to cure for at least eight hours before exposing it to liquid.

Figure 3-9

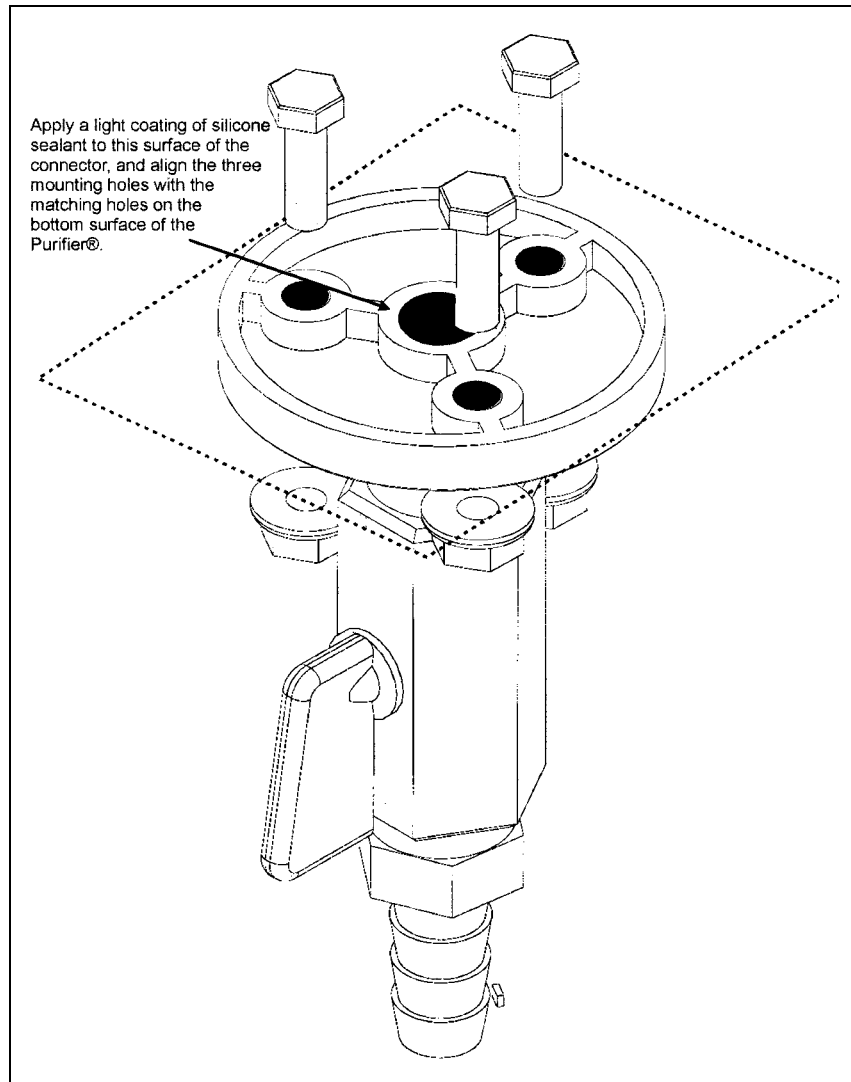

## Initial Certification

Prior to use, all Purifier cabinets should be certified by a qualified certifier. Under normal operating conditions, the Purifier cabinet should be recertified at least annually, and when moved or serviced. The certifier should perform the following tests, as recommended in NSF International Standard Number 49:

- Downflow Velocity Profile Test
- Inflow Velocity Test
- Airflow Smoke Patterns
- HEPA Filter Leak Test
- Electrical Leakage and Ground Circuit Resistance Test
- Vibration Test \*
- Noise Level Test \*
- Lighting Intensity Test \*
- Cabinet Leak Test\*\*

\*These tests are user comfort related tests and may be omitted at the user's or certifier's discretion.

\*\*Because of the complexity of this test, it may be performed when deemed necessary by the customer and certifier.

If you have any questions regarding certification agencies or need assistance in locating one, contact Labconco's Product Service Department at 1-800-522-7658 or 816-333-8811.

## Your Next Step

After your Purifier has been installed and certified, you are ready to proceed to *Chapter 4: Theory Of Operation And Safety Precautions*.



---

# **CHAPTER 4**

# **THEORY OF**

# **OPERATION AND**

# **SAFETY**

# **PRECAUTIONS**

All biohazard cabinets operate using the following principles:

- Filtration and retention of particulates by High Efficiency Particulate Air (HEPA) filter(s)
- Laminar airflow (sometimes)
- Directional airflow

The major components in a Total Exhaust Biohazard Cabinet are:

- The HEPA filter(s)
- The motor/blower to force air through the unit
- A speed control for the motor
- Cabinet air intakes (grilles), ductwork and air balance controls
- The remote blower

## HEPA Filters

HEPA filters are disposable, dry-type particulate filters. The filter material or media is typically made of borosilicate microfibers that are made into a thin sheet, in a process similar to the production of paper. This sheet is folded, or pleated to increase its surface area. The pleats are held in place by aluminum diffusers or by beads of glue that add rigidity to the media pack. The media pack is then set into a suitable frame, and the perimeter sealed to the filter frame, as shown in Figure 4-1.



**The HEPA filter media is very fragile. Do not touch or contact the media surface. If you think the surface of a HEPA filter is damaged, DO NOT USE THE CABINET. Have the HEPA filter integrity tested by a qualified certifier before using the cabinet.**



**HEPA Filters are only effective against particulate material. Gases will pass through the filter.**

Figure 4-1

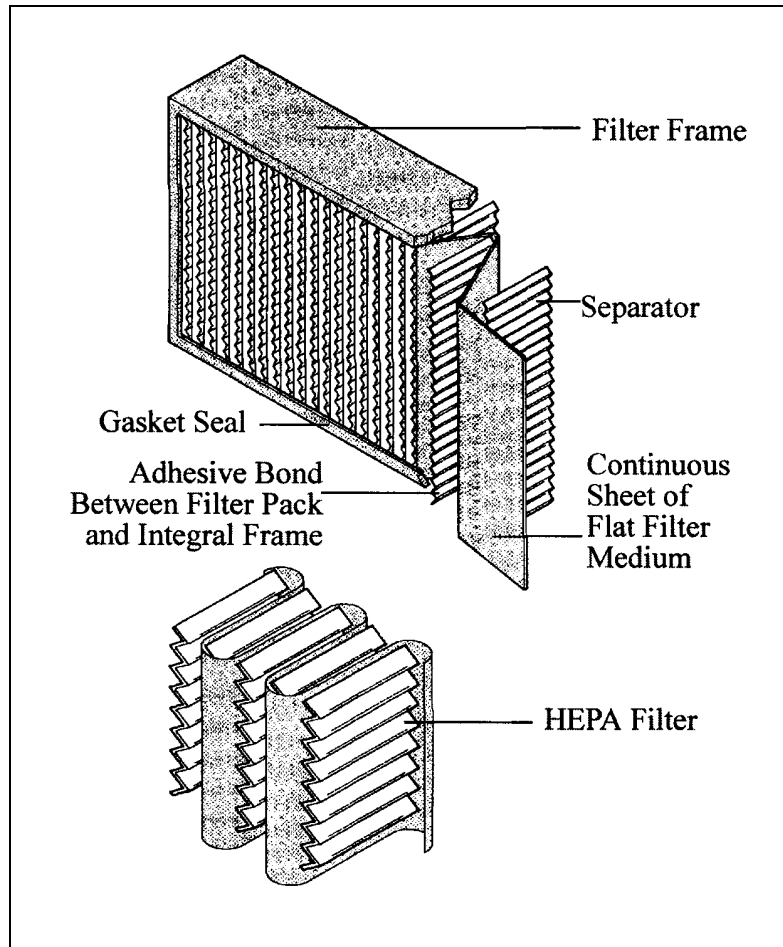

## Laminar Airflow

Laminar airflow is defined as the movement of a body of air in a single direction, with a uniform velocity. In practice, the laminar downflow of air in the cabinet captures any aerosol generated in the work area of the cabinet, and directs it to the HEPA filters. In order to be true laminar downflow, a number of individual downflow velocity test points (The Downflow Velocity Profile) must be  $\pm 20\%$  of the average of all the test points. This is shown graphically in Figure 4-2.

Figure 4-2

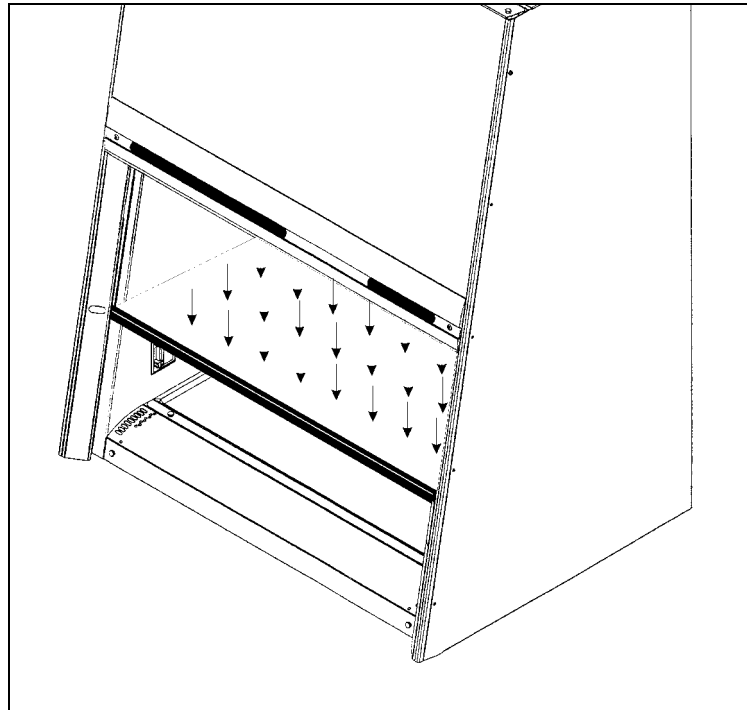

## Directional Airflow

Directional airflow also plays a key role in biosafety cabinet performance. Air is drawn into the front of the cabinet at the front grille. This “curtain” of air makes it more difficult for aerosols to escape out of the work area of the cabinet and into the outside environment. This airflow is often calculated and referred to as the **Inflow Volume** or **Average Inflow Velocity**. This is shown graphically in Figure 4-3.



**Figure 4-3**

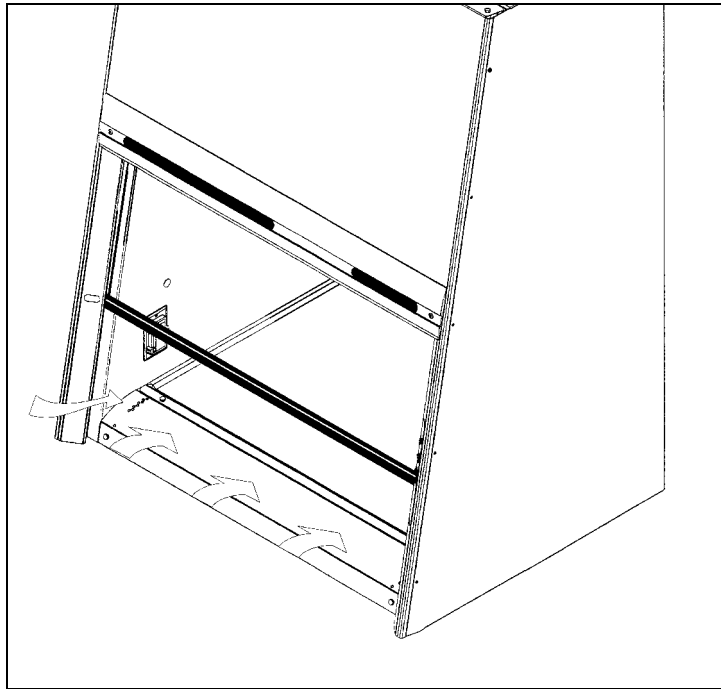

## **Motor/Blower**

The motor/blower assembly pulls air into the top of the cabinet, and forces it through the supply HEPA filter. This filtered air flows down through the work area. All of the downflow air, plus the inflow volume are then pulled through the exhaust HEPA filter and out of the laboratory.

## Speed Control



**The speed control should only be adjusted by a qualified certifier.**

The speed control is an electronic circuit that allows the certifier to set the motor speed by adjusting its voltage. The control will 'hold' this voltage, as line voltage fluctuates, allowing for stable operation. The Purifier speed control is rated for 25 Amps current, far in excess of the motor's normal current draw, to allow for greater reliability.

## Cabinet Air Intakes (Grilles), Ductwork and Air Balance Controls

Cabinet containment and performance are affected by the location, size, and pattern of the grilles at the front and rear of the work area.



**Never block or obstruct the grilles of the Purifier.**

The internal ductwork of the Purifier conveys the air from the work area to the exhaust HEPA filter. The plenum above the supply HEPA filter of the Purifier is unique in the industry, utilizing perfect manifold technology to deliver a more uniform airflow to the supply HEPA filter, optimizing filter loading and operational life.

The volume of air exhausted by the Purifier is controlled by an exhaust damper system.

## Safety Precautions



The Purifier Biohazard Cabinet should be certified by a qualified certification technician before its initial use. The cabinet should be recertified whenever it is relocated, serviced or at least annually thereafter.



Some components of the Purifier Biohazard Cabinet should only be serviced by a qualified certification technician. Some internal components of the Purifier may become contaminated during operation of the unit. Only experienced personnel competent in the decontamination procedure should decontaminate the cabinet before servicing contaminated components. If you have any questions regarding certification agencies, or need assistance in locating one, contact Labconco's Product Service Department at 800-522-7658 or 816-333-8811.



Ensure that the unit is connected to electrical service in accordance with local and national electrical codes. Failure to do so may create a fire or electrical hazard. Do not remove or service any electrical components without first disconnecting the Purifier from electrical service.

Avoid the use of flammable gases or solvent in the Purifier. Care must be taken to ensure against the concentration of flammable or explosive gases or vapors. An open flame should NOT be used in the Purifier. Open flames may disrupt the airflow patterns in the cabinet,

**burn the HEPA filter and/or damage the filter's adhesive. Gases under high pressure should not be used in the Purifier cabinet, as they may disrupt the airflow patterns of the cabinet.**

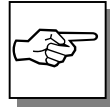

HEPA FILTERS ARE ONLY EFFECTIVE FOR THE ENTRAPMENT OF PARTICULATE MATTER. MANIPULATIONS WHICH GENERATE GASES OR VAPORS, I.E., TOXIC CHEMICALS OR RADIONUCLIDES, MUST BE EVALUATED CAREFULLY FROM THE STANDPOINT OF BUILDUP TO DANGEROUS LEVELS, THE DECONTAMINATION OF THE CABINET, AND COMPLIANCE WITH APPLICABLE REGULATIONS.



**The surface of the HEPA filters are fragile and should not be touched. Care must be taken to avoid puncturing either HEPA filter during installation or normal operation. If you suspect that a HEPA filter has been damaged, DO NOT use the cabinet; contact a local certification agency or Labconco at 800-821-5525 or 816-333-8811 for recertification information.**

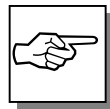

THE HEPA FILTERS IN THE PURIFIER CABINET WILL GRADUALLY ACCUMULATE AIRBORNE PARTICULATE MATTER FROM THE ROOM AND FROM WORK PERFORMED IN THE CABINET. THE RATE OF ACCUMULATION WILL DEPEND UPON THE CLEANLINESS OF THE ROOM AIR, THE AMOUNT OF TIME THE CABINET IS OPERATING AND THE NATURE OF WORK BEING DONE IN THE CABINET. IN

TYPICAL INSTALLATIONS AND USAGE, THE HEPA FILTERS WILL LAST APPROXIMATELY FIVE YEARS OR MORE BEFORE REQUIRING REPLACEMENT.



**Proper operation of the cabinet depends largely upon the cabinet's location and the operator's work habits. Consult the Installation and Normal Operation sections of this manual for further details.**

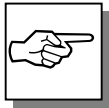

AVOID DIRECT EXPOSURE OF PLASTIC OR COATED MATERIALS TO ULTRAVIOLET (UV) RADIATION. NEVER BYPASS THE SAFETY INTERLOCK OR ATTEMPT TO WORK IN THE PURIFIER CABINET WHEN THE UV LIGHT IS ON.

WHEN SURFACE DISINFECTING THE PURIFIER:

- AVOID SPLASHING THE DISINFECTING SOLUTION ON SKIN OR CLOTHING.
- ENSURE ADEQUATE VENTILATION.
- CAREFULLY FOLLOW THE MANUFACTURER'S SAFETY INSTRUCTIONS WHEN HANDLING DISINFECTANTS AND ALWAYS DISPOSE OF DISINFECTING SOLUTIONS IN ACCORDANCE WITH LOCAL AND NATIONAL LAWS.

DO NOT ALLOW DISINFECTANTS WITH HIGH CONCENTRATIONS OF FREE CHLORINE TO CONTACT THE STAINLESS STEEL COMPONENTS OF THE PURIFIER FOR A LONG PERIOD OF TIME. FREE CHLORINE

WILL CORRODE STAINLESS STEEL AFTER EXTENDED CONTACT.



The electrical receptacle cover, because of its construction, may be difficult to surface decontaminate. In the event of gross contamination, the cover should be removed, sterilized and/or decontaminated as required and discarded. The receptacle cover should then be replaced with the repair part listed in *Appendix A: Purifier Components*.

Biohazard cabinets should be decontaminated using formaldehyde gas for any of the following reasons:

- Maintenance work requiring entry into contaminated areas.
- Before HEPA filter changes.
- Before performing performance tests requiring entry into contaminated areas.
- Before moving the cabinet.
- Before changing research programs.
- After the gross spill of biohazardous material.

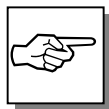

THE PROCEDURES FOR PERFORMING A GASEOUS DECONTAMINATION ARE THOROUGHLY OUTLINED IN THE U.S. DEPARTMENT OF HEALTH, EDUCATION AND WELFARE BOOKLET ENTITLED “Formaldehyde Decontamination of Laminar Flow Biological Safety Cabinets,” WHICH IS AVAILABLE FROM THE NATIONAL INSTITUTES OF HEALTH, DIVISION OF SAFETY, BETHESDA, MARYLAND 20892, OR FROM LABCONCO CORPORATION.

## Your Next Step

After you understand the theory of operation and safety precautions, you are ready to proceed to *Chapter 5: Using Your Purifier*.





---

# CHAPTER 5

# USING YOUR

# PURIFIER

## Operating the Sliding Sash

Because of the Purifier's counterbalanced, anti-racking sash mechanism, it will take only a few pounds of force to move the sash up or down, and you can operate the sash smoothly with one or two hands positioned anywhere along the handle.

The sash position alarm and safety interlock system sense the sashes position and act appropriately. Your Purifier is designed to operate with an 8-inch sash opening. Raising the sash above its operating height will activate the audible and visual alarms. The audible alarm can be temporarily muted (for approximately five minutes) by depressing and releasing the alarm silence button. Closing the sash back to its operating position will reset the alarm and defeat the muting of the alarm. The safety interlock system senses when the sash is closed, and will shut off the cabinet blower (to prevent it from overheating). The interlock also allows the optional ultraviolet (UV) lamp to operate only when the sash is closed, to protect the operator from irradiation.

1. To start the Purifier, raise the sash until you feel the sash tactile position indicator (TPI). The TPI functions by increasing the resistance you feel on the sash as it nears its proper operating position. Once in position, the TPI will 'set', requiring additional upward force to be raised further. The correct sash position can be confirmed by aligning the handle of the sash with the indicator decal located on the left side of the opening. The indicator decal is shown in Figure 5-1.

**Figure 5-1**

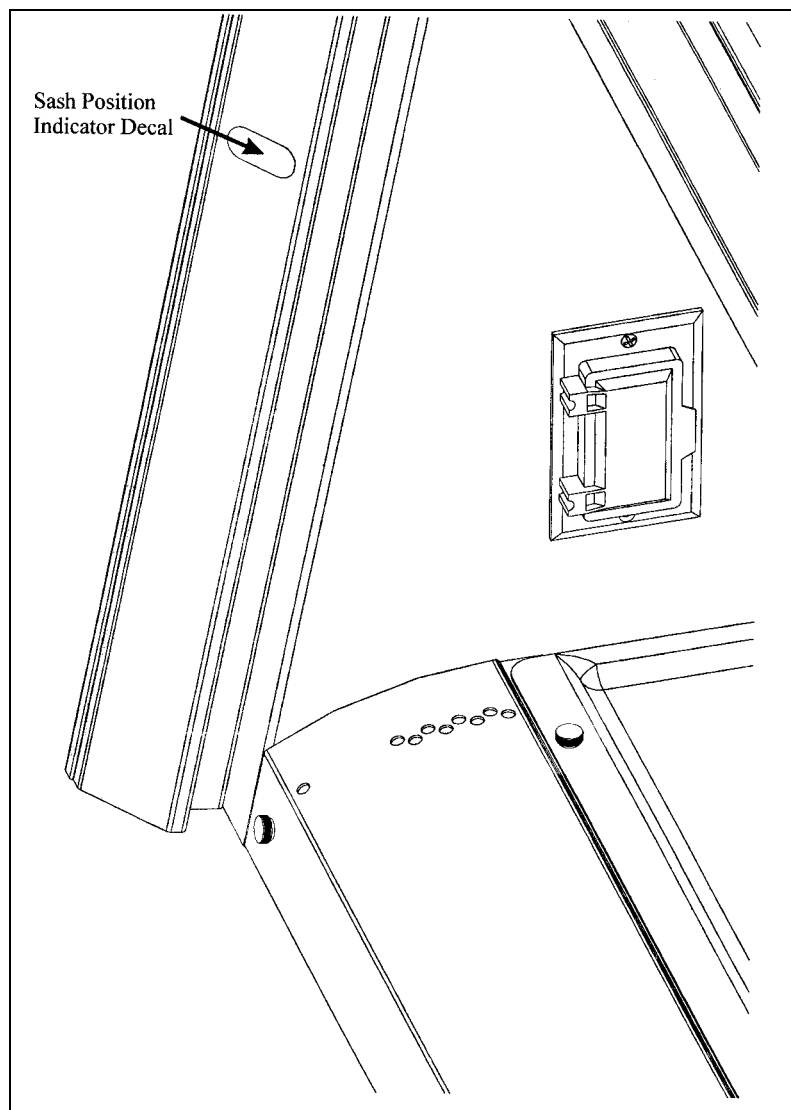

2. Turn the blower switch to the 'On' position, as shown in Figure 5-2. The audible and visual alarms will self-test and be activated for approximately three seconds. The alarms will then shut off. If the alarms continue after three seconds, recheck the sash position.

**Figure 5-2**

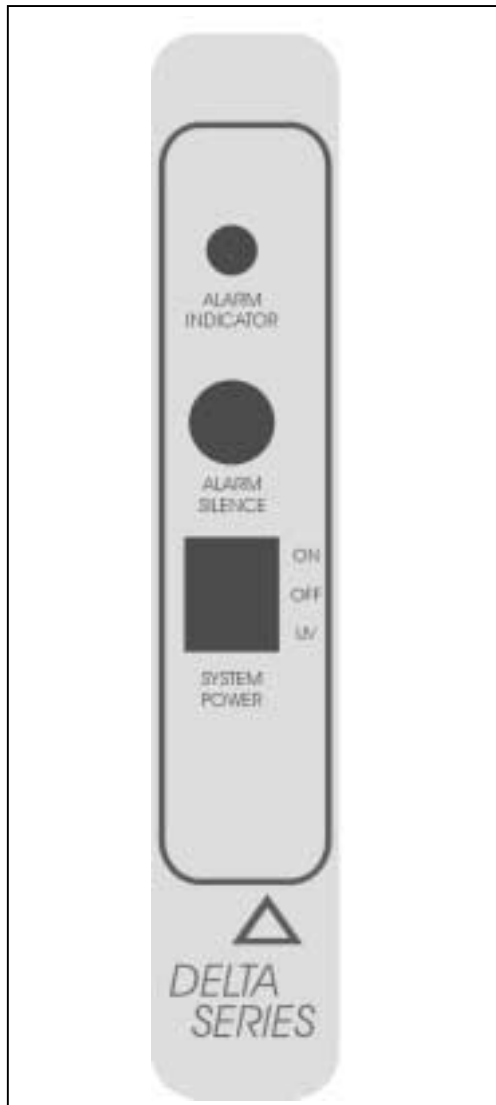

The Total Exhaust Purifier Cabinets are equipped with an alarm system that monitors the volume of air exhausting from the cabinet. If the exhaust volume drops below the minimum requirement, the following occurs:

- An audible alarm sounds.
- The red "Alarm" indicator light illuminates.
- The cabinet blower, supplying the downflow air in the work area, shuts off.



**During an alarm, the cabinet blower shuts off to prevent air from escaping the work area of the cabinet.**



**If the alarm reactivates after five seconds, DO NOT continue to use the Purifier. NEVER OVERRIDE THE ALARM RESET SWITCH TO CONTINUE WORKING IN THE CABINET. You MUST correct the problem in the exhaust system before resuming operations.**

## If The Alarm Activates

The most common causes of alarm activation are:

- Mechanical failure of the external blower.
- An obstruction or leak in the exhaust system.
- Loading of the exhaust HEPA filter.



**If the alarm sounds during use, immediately take appropriate action to prevent contamination to you and other personnel in the area.**

## Resetting The Alarm System

Once the cause of the face velocity alarm has been determined and corrected, the alarm may be reset by depressing the "Alarm Silence" switch.



**IMPORTANT: If pressing the "Alarm Silence" switch does not reset the cabinet into normal operation, or the alarm activates frequently, DO NOT continue to use the Purifier. NEVER OVERRIDE THE ALARM RESET MECHANISM TO CONTINUE WORKING IN THE CABINET. You MUST correct the problem in the exhaust system before resuming operations.**

## Working In Your Purifier

### Planning

- Thoroughly understand procedures and equipment required before beginning work.
- Arrange for minimal disruptions, such as room traffic or entry into the room while the cabinet is in use.

### Start-up

- Turn off UV light if included.
- Slowly raise the sash until the TPI engages at the proper height. Confirm the sash is at its proper height by examining the sash indicator decal located on the left side of the work area.
- Turn on fluorescent light and cabinet blower.
- Check the return air grilles for obstructions, and note the pressure gauge reading.
- Allow the cabinet to operate unobstructed for 5 minutes.
- Wash hands and arms thoroughly with germicidal soap.
- Wear a long sleeved lab coat with knit cuffs and over-the-cuff rubber gloves. Use protective eyewear. Wear a protective mask if appropriate.

### Wipe-Down

- Raise the sash to its full open position (approximately 19 inches open). Mute the alarm by depressing the "Alarm Silence" switch.

- Wipe down the interior surfaces of the cabinet with 70% ethanol, or a suitable disinfectant, and allow to dry.

### **Loading Materials and Equipment**

- Only load the materials required for the procedure. Do not overload the cabinet.
- Do not obstruct the front, side, or rear return air grilles.
- Large objects should not be placed close together.
- Slowly close the sash until the TPI is engaged correctly.
- After loading the cabinet, wait two to three minutes to purge airborne contaminants from the work area.

### **Work Techniques**

- Keep all materials at least 4 inches inside of the sash, and perform all contaminated operations as far to the rear of the work area as possible.
- Segregate all clean and contaminated materials in the work area.
- Arrange materials to minimize the movement of contaminated materials into clean areas.
- Keep all discarded contaminated material to the rear of the work area.
- Avoid moving materials or the operator's hands and arms through the front access opening during use.
- Avoid the use of an open flame.
- Use proper aseptic technique.
- Avoid using techniques or procedures that disrupt the airflow patterns of the cabinet.
- If there is a spill or splatter during use, all objects in the cabinet should be surface decontaminated before removal. Thoroughly disinfect the working area of the cabinet **WHILE IT IS STILL IN OPERATION**. This will prevent the release of contaminants from the cabinet.

### **Final Purging**

- Upon completion of work, the cabinet should be allowed to operate for two to three minutes undisturbed, to purge airborne contaminants from the work area.

### **Unloading Materials and Equipment**

- Objects in contact with contaminated material should be surface decontaminated before removal from the cabinet.
- All open trays or containers should be covered before being removed from the cabinet.

### **Wipe-Down**

- Wipe down the interior surfaces of the cabinet with 70% ethanol, or a suitable disinfectant, and allow to dry.
- Periodically lift the work surface and wipe down the area beneath it.
- Inspect and clean the towel catch located at the rear of the work area, beneath the work pan.
- Dispose of rubber gloves appropriately, and have lab coat laundered properly.
- Wash hands and arms thoroughly with germicidal soap.

### **Shutdown**

- Turn off the fluorescent light and cabinet blower, close the sash, and turn on the UV light if appropriate.

## **Safety and Comfort**

Many factors in our work environment determine whether we work efficiently and in a manner that promotes good health and safety. By considering, acting on, and periodically reevaluating the recommendations in this section, it is possible to create a safer, more comfortable, healthful, and efficient work environment.



**Working intensely or for a long time in uncomfortable or unnatural positions poses risks.**

### **Organizing Your Adjustments**

The order in which you make various adjustments to your body position and work area may vary depending on the adjustability of your furniture.

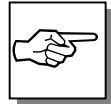

LABCONCO OFFERS AN OPTIONAL ERGONOMIC CHAIR AND ADJUSTABLE FOOTREST. FOR FURTHER INFORMATION SEE *Appendix D: Purifier Accessories*.

PAY PARTICULAR ATTENTION TO ADJUSTING YOUR POSTURE IN THE AFTERNOON WHEN YOU MAY TEND TO GET FATIGUED.

WHEN YOU REPOSITION ANY ONE PART OF YOUR BODY, YOU MANY NEED TO ADJUST OTHER PARTS AS WELL.



**Don't sit in one fixed posture all day.**

### **Feet, Knees, and Legs**

Make sure your feet can rest solidly and comfortably on the floor or footrest while sitting. Use an adjustable chair that allows your feet to rest firmly on the floor, or use a footrest. If you use a footrest, be sure it is wide enough to accommodate different leg positions within your comfort zone.

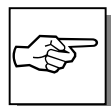

REST YOUR FEET FIRMLY ON THE FLOOR OR A FOOTREST.



**Don't dangle your feet and compress your thighs.**



### **Providing Enough Leg Room**

Be sure you have sufficient space under your work surface for your knees and legs. Avoid concentrated pressure points along the underside of your thigh near the knee and the backside of your lower leg. Stretch your legs and vary your leg posture throughout the day.

### **Leg Comfort**

Vary your leg positions throughout the day.



**Avoid placing boxes or other items under the cabinet that limit your leg room. You should be able to pull your chair all the way up to your Purifier without interference.**

### **Walk**

Get up from your Purifier periodically and take brief walks.

### **Back**

Use your chair to fully support your body. Distribute your weight evenly and use the entire seat and backrest to support your body. If your chair has adjustable low back support, match the contours of the chair's backrest to the natural curve of your lower spine. Always make sure your lower back is well supported. Make sure it feels comfortable in the position in which you are working.

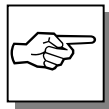

**DISTRIBUTE YOUR WEIGHT EVENLY AND USE THE ENTIRE SEAT AND BACKREST TO SUPPORT YOUR BODY.**



**Don't slouch forward.**

### **Adjust often**

If your chair is adjustable, experiment with the adjustments to find numerous comfortable positions, then adjust the chair frequently.



**If you are using a chair for the first time, or if you share a chair with someone else, don't assume the settings are properly set for you.**

### **Forearms, Wrists, and Hands**

Keep your forearms, wrists, and hands aligned in a straight, natural position. Avoid bending or angling your wrists while working.

### **Don't Anchor Your Wrists**

When working, do not anchor or rest your wrists on the work surface. Resting your palms while working may be harmful because it can cause you to bend your wrists back and can apply pressure to the undersides of your wrists.

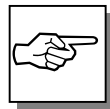

**MAINTAIN A STRAIGHT, NATURAL WRIST POSITION WHILE WORKING.**



**Don't rest your palms on the work surface while working.**

**Don't anchor your wrists, this may cause unnecessary strain.**

### **Shoulders and Elbows**

Adjust your chair height or Purifier height so that your shoulders are relaxed and your elbows hang comfortably at your sides.

### **Relax**

Remember to relax, particularly in areas where muscle tension often builds, such as your shoulders.

### **Eyes**

Working at your Purifier for long periods can be a visually demanding task and may cause your eyes to become irritated and fatigued. Therefore, you should give special attention to vision care, including the following recommendations:

### **Resting Your Eyes**

Give your eyes frequent breaks. Periodically look away from the work area and focus at a distant point. This may also be a good time to stretch, breathe deeply, and relax.

### **Cleaning Your Sash and Glasses**

Keep your sash and glasses clean.

### **Having Your Eyes Examined**

To be sure that your vision is adequately corrected, have your eyes examined regularly by a vision care specialist. If you wear bifocals or trifocals, you may find monofocal glasses more comfortable for cabinet use.

### **Eye comfort**

While working in your Purifier, and also while resting your eyes, remember to blink. This helps keep your eyes naturally protected and lubricated, and helps prevent dryness, a common source of discomfort.

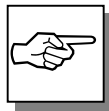

**GIVE YOUR EYES FREQUENT RESTS BY FOCUSING THEM ON A DISTANT POINT.**

## **Arranging Your Work Area**

### **Eliminating Glare and Reflections on the Sash**

Take the time to eliminate glare and reflections. To control daylight, use blinds, shades, or drapes, or try other glare-reducing measures. Use indirect or reduced lighting to avoid bright spots on the sash. If glare is a problem, consider these actions:

- Turn off or reduce ceiling lights and use task lighting (one or more adjustable lamps) to illuminate your work.



**Avoid compromising your posture to compensate for glare or reflections.**

### **Positioning Work Materials**

Position work materials directly in front of you to avoid twisting your neck and torso. This makes it possible to work with your shoulders relaxed and your upper arms hanging freely at your sides.

### **Minimizing Your Reach**

Arrange your frequently used materials to minimize the distance you reach for them.

### **Hand Manipulation**

Notice how you use your fingers and hands while working. Avoid keeping any unnecessary tension in your thumbs and fingers. Observe whether you have a heavy touch or a light touch while working.

### **Reaching for Materials**

To reach material that is not near your hands, move your whole arm; avoid stretching your fingers and angling your wrists.

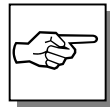

RELAX YOUR THUMBS AND FINGERS WHILE WORKING; NOTICE AND RELEASE EXCESS TENSION.



**Don't work with unnecessary tension in your thumbs and fingers.**

### **Wrist Position**

Use your whole arm and shoulder to move objects, not just your wrist. Don't rest or anchor your wrist while moving items; keep your wrist, arm, and shoulder free to move.

### **Aligning Forearms, Wrists, and Hands**

When working in the Purifier, keep your forearms, wrists, and hands comfortably aligned with each other in a straight, natural line. Avoid bending or angling your wrists.

### **Taking Breaks and Varying Your Tasks**

As noted earlier, your furniture placement, lab equipment, and lighting are only a few of the factors

that determine comfort. Your work habits are also very important. Remember the following:

- Take breaks.
- When you work at your Purifier for long periods, take short breaks at least once per hour and preferably more often. You may find that frequent, short breaks will benefit you more than fewer, longer breaks.
- If you find that you forget to take breaks, use a timer.
- During your breaks, stand up and stretch, especially any muscles and joints you may have held in an extended static posture while working.

### **Vary Your Tasks**

Examine your work habits and the types of tasks you perform. Break up the routine and try to vary your tasks during the day. By doing so, you may avoid sitting in one position or performing the same activities continuously for several hours using your hands, arms, shoulders, neck, or back.

### **Reduce Sources of Stress**

Take an inventory of things at work that are stressful to you. If you perceive that your physical or psychological health is being affected, take time to evaluate what changes you can make to reduce or eliminate the sources of stress.

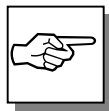

BREATHE FRESH AIR DEEPLY AND REGULARLY. THE INTENSE MENTAL CONCENTRATION THAT MAY ACCOMPANY WORK IN A BIOSAFETY CABINET MAY TEND TO CAUSE BREATH-HOLDING OR SHALLOW BREATHING.

### **Self-Check**

To increase your comfort and reduce potential safety risks, use this checklist to help you evaluate your work posture and habits.

### **Seated Position**

- Have you found a range of seated postures that are most comfortable for you?
- Are you changing postures within your "comfort zone" throughout the day, especially in the afternoon?
- Are your feet firmly planted?
- Are the undersides of your thighs near your knees free of pressure?
- Are the backs of your lower legs free of pressure? Is there sufficient space under your cabinet for your knees and legs?
- Is your lower back supported?

### **Shoulders, Arms, Wrists, and Hands**

- Are your shoulders relaxed?
- Are your hands, wrists, and forearms aligned in a straight, natural position?
- Are your elbows in a relaxed position near your body?
- Are items you use frequently easy to reach?

### **Eyes**

- Do you rest your eyes frequently by focusing on a distant point?
- Do you get your eyes examined regularly by a vision care specialist?
- Do you blink enough?
- If you wear bifocals or trifocals, do you avoid tilting your head back to see your work?

### **Working Style**

- Are you training your fingers to relax when they become tense?
- Do you use your whole arm to reach for objects not located near your fingers?
- Is your work positioned directly in front of you?
- Are your wrists straight and your shoulders relaxed?
- Have you eliminated glare and bright reflections on the sash, without compromising your posture?

**General Prevention**

- Do you take breaks and walk around briefly, preferably once per hour?
- Do you exercise regularly?
- Periodically, do you take inventory of the stress in your life and change what is within your control to change?

## **Your Next Step**

After you understand how to operate and work in the Purifier, you are ready to proceed to *Chapter 6: Maintaining Your Purifier*.





---

# CHAPTER 6

## MAINTAINING YOUR PURIFIER

Now that you have an understanding of how to work in the Purifier, we will review the suggested maintenance schedule and the common service operations necessary to maintain your Purifier for peak performance.



**Many of the service operations should be performed only by trained and experienced certification technicians after the cabinet has been properly decontaminated. DO NOT attempt to perform these operations if you are not properly trained. The service operations that require qualified certifiers are preceded by the wrench icon.**

### Routine Maintenance Schedule

#### Weekly

- Using 70% ethanol, or a suitable disinfectant, surface disinfect the inside of the cabinet, and the work surface.

- Using an appropriate glass cleaner, clean the sash and the surface of the UV lamp, if so equipped.
- Operate the cabinet blower, noting the pressure reading in an operational log.

**Monthly (or more often as required)**

- Using a damp cloth, clean the exterior surfaces of the cabinet, particularly the front and top of the cabinet, to remove any accumulated dust.
- Disinfect and lift the work surface. Surface disinfect the lower plenum with a solution of 70% ethanol, or a suitable disinfectant. Check the towel catch for retained materials.
- Check all service valves, if so equipped, for proper operation.
- All weekly activities.

**Annually**

- Have the cabinet recertified by a qualified certification technician.
- Replace the UV lamp, if so equipped.
- All monthly activities.

**Biannually**

- Replace the fluorescent lamp.

## Service Operations

**Work Surface Removal:**



**The work surface of the cabinet must be thoroughly decontaminated before removing it.**

1. Loosen and remove the thumbscrews located at the front of the work surface, as shown in Figure 6-1.
2. **Only loosen** the thumbscrews located at the rear of the work surface.
3. Lift the front edge of the work surface up and pull it out of the cabinet work area.

**Towel Catch Removal:**

Although not normally required, the towel catch can be removed for cleaning, inspection, etc.



**The work surface of the cabinet and the towel catch must be thoroughly decontaminated before removing either.**

1. Remove the work surface as described above.
2. Loosen and remove the thumbscrews located at the rear of the work surface.
3. Surface decontaminate the towel catch before removing it.

**Figure 6-1**

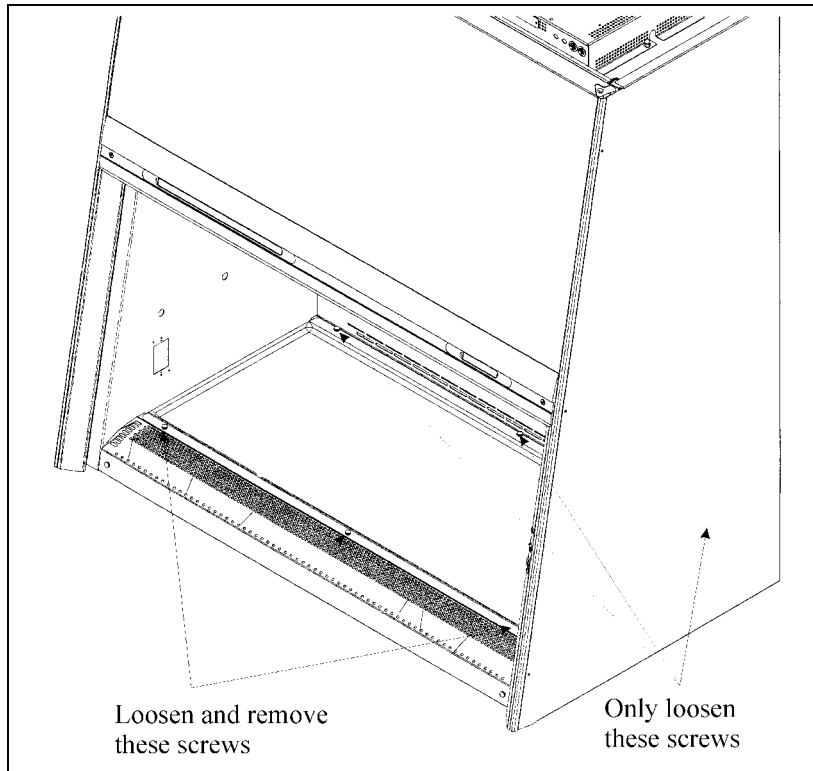

### **Front Panel Removal:**

1. Locate and remove the two Phillips screws that secure the front panel as shown in Figure 6-2.
2. Swing the bottom of the dress panel out to clear the fluorescent light and then lift the front dress panel straight up and away from the cabinet.

**Figure 6-2**

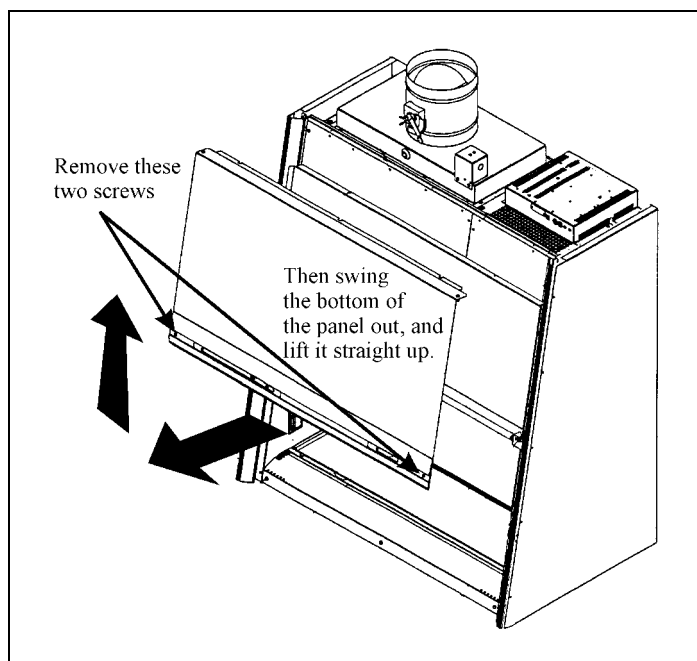

### **Changing the Fluorescent Lamp:**

1. Unplug the cabinet.
2. Remove the front dress panel as noted in Figure 6-2.
3. Remove the fluorescent lamp by rotating it 90 degrees and pulling it straight up and out of its sockets.
4. Remove the fluorescent lamp by pushing it to the left and swinging it out of the right lamp socket.
5. Install the new lamp by reversing the removal procedure.

4'

6'

### **Changing the Optional UV Lamp:**

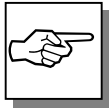

FOR OPTIMUM PERFORMANCE,  
THE UV LAMP SHOULD BE  
CHANGED ON AN ANNUAL BASIS.



**The UV lamp and the work area of the cabinet must be thoroughly decontaminated before removing the lamp.**

1. Start the cabinet and let it operate for 5 minutes.
2. Thoroughly surface decontaminate the UV lamp and the work area of the cabinet.
3. Unplug the cabinet.
4. Raise the sash to its full open position.
5. Remove the UV lamp by rotating it 90 degrees and lifting it straight up and out of its sockets.
6. Remove the UV lamp by pushing it to the left and swinging it out of the right lamp socket.
7. Install new lamp by reversing the removal procedure.

4'

6'

### **Resetting a Circuit Breaker:**

To reset any of the circuit breakers located on the front of the electronics module, depress the white button until it sets.



**The service operations listed in the rest of this chapter should only be performed by a qualified certifier.**

## **Downflow Velocities**

The average downflow velocity for all model Purifiers should be set at  $55 \pm 5$  FPM.

## **Downflow Velocity Grid Patterns**

The downflow velocity test grid for all model Purifiers is listed on the data plate on the lower right side of the airfoil. If the decal is missing or obliterated, contact Labconco's Product Service Department at 1-800-522-7658 for further details.

## **Air Volumes Defined**

The total exhaust volume is the amount of air that is being exhausted out of the cabinet, and into the exhaust system. The inflow is the amount of air that flows through the front access opening.

## **Measuring the Total Exhaust Volume**

Measure the airflow in the exhaust duct in accordance with American Society of Heating, Refrigerating and Air-Conditioning Engineers (ASHRAE) recommended procedures. It should correspond to the airflow values shown in Table 6-1.

Table 6-1

<b>Purifier Airflow Data</b>					
Model Number	Average Inflow Velocity (FPM)	Work Opening Area (sq. ft.)	Exhaust volume of Cabinet (CFM)*	Normal Exhaust Volume of Cabinet (CFM)**	Alarm Setpoint Volume (CFM)
36210-xx	105	2.69	743-771	772	730
36214-xx	105	4.03	1111-1151	1187	1091

\*Using a direct read instrument sealed to the sash opening with the air intake blocked.

\*\*Measured using a pitot traverse of the exhaust duct as per ASHRAE recommendations.



**Balancing of the exhaust flow is accomplished by adjusting the cabinet's exhaust damper. Changing the damper setting or the speed control will affect the inflow and downflow values. Both must be checked after any adjustment.**

**Downflow and inflow values and measurement procedures are described fully in Table 3-6, and Chapter 6: Maintaining Your Purifier.**

## Exhaust Control System Adjustment



**Adjusting the exhaust control system will have an effect on the air velocities and the efficiency of the cabinet. The exhaust control system should only be adjusted by a qualified certification technician as part of the recertification procedure.**

1. To adjust the total exhaust volume, locate the exhaust damper on the top of the cabinet.
2. Lock the damper in place using the attached wing nut when the proper total exhaust volume is obtained, as shown in Table 6-1.

## Measuring the Cabinet Inflow Volume - Primary Method

The average inflow velocity for all Purifiers is  $105 \pm 5$  FPM, and should be determined by converting the inflow volume to the average inflow velocity. The inflow volume is measured directly by sealing a direct inflow measuring instrument to the face of the unit. When corrected for local conditions, dividing the inflow volume by the opening area will yield the average inflow velocity as shown in table 6-2.

**Table 6-2**

<b>Purifier Model</b>	<b>Sash Height (inches)</b>	<b>Avg. Inflow Velocity (FPM)</b>	<b>Work Opening Area (sq. ft.)</b>	<b>Inflow Volume (CFM)</b>
36210	8	$105 \pm 5$	2.69	269-296
36214	8	$105 \pm 5$	4.03	403-443

## Inflow Velocity Calculation - Secondary Method

If the primary method cannot be performed, the secondary inflow calculation method should be performed. The secondary method uses a hot wire thermoanemometer. In this method, the sash is lowered until the open area of the sash equals one square foot, and a series of velocity readings are taken at the front of the unit.

1. For each model Purifier, the sash height should be adjusted and measured such that a vertical line from the lowest surface of the sash handle to the front grille should equal the following height:



**Table 6-3**

<b>Purifier Models</b>	<b>Sash height opening</b>
36210	2.97 in (75 mm)
36214	1.99 in (51 mm)

2. Start the Purifier, and let it operate for at least 5 minutes.
3. Establish the necessary correction factor to the thermoanemometer to ensure compliance with its performance in a calibrated wind tunnel. This data should be available from the calibrator of the thermoanemometer.
4. Calculate the manufacturer's recommended correction factor(s) to correct for local conditions of temperature, humidity, barometric pressure, altitude, etc.
5. Measure a number of test points, 4 inches from each side wall, and at intervals of the following distance for each of these models:

**Table 6-4**

<b>Model Numbers</b>	<b>Distance Between each Test Point (inches)</b>	<b>Total Number of Test Points</b>
36210	4.05	11
36214	4.03	17

6. Take a series of inflow velocities by placing the sensor of the thermoanemometer at the test points, in the center of the opening, leaning the body of the probe against the front of the grille.
7. Apply the wind tunnel correction and local condition correction factors to the thermoanemometer readings.
8. Multiply the resulting velocities by the following Purifier correction factor to determine flow rates:

**Table 6-5**

<b>Model Numbers</b>	<b>Purifier Correction Factors (FPM TO CFM)</b>
36210	1.17
36214	1.23

9. Calculate the average of all the flow rates.
10. The resulting value is the inflow volume in cubic feet per minute (CFM). In order to convert this value to the average inflow velocity of feet per minute (FPM), divide the volume by the sash open area given in Table 6-5 below.

**Table 6-6**

<b>Model Numbers</b>	<b>Sash Open Area (square feet)</b>
36210	2.69
36214	4.03

11. The resulting value will be the estimated average inflow velocity in FPM.

## **Calibration of the Face Velocity Alarm**



**A qualified certification technician should calibrate the Face Velocity Alarm. The alarm switch is set at the factory at its lowest pressure setting, and it will need to be calibrated before using the Purifier.**

1. Set the exhaust damper so that the exhaust volume is at the alarm setpoint as indicated in Table 6-1, and mark the damper position.
2. With the Purifier running, remove the hole cover and turn the adjusting screw, as shown in Figure 6-3 very slowly clockwise (increasing the pressure setting) until the alarm is activated. This is the alarm setpoint.
3. Confirm the alarm operation by opening the damper slightly and pressing the “Alarm Silence” switch. The cabinet will operate normally. While the cabinet is running, slowly return the damper to its setpoint. If the alarm does not sound at the setpoint, repeat steps 2 and 3 until proper operation is obtained.

4. Open the exhaust damper until the exhaust volume is at the normal exhaust volume, as indicated in Table 6-1.
5. With the exhaust volume set, the downflow can be established as described in *Chapter 6: Maintaining Your Purifier*.

Figure 6-3

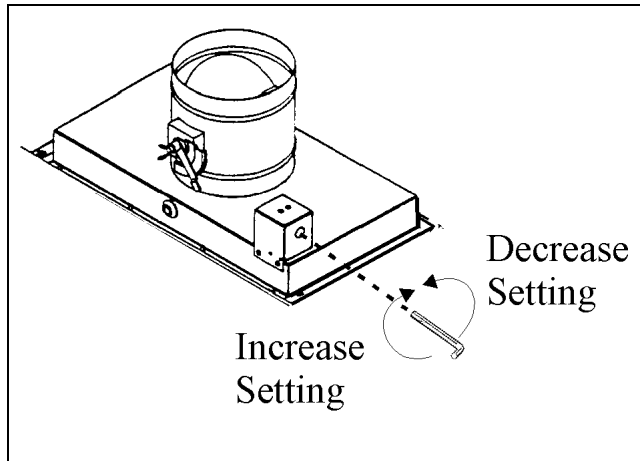

## Electronics Module Access



**The electronics module assembly should be serviced by a qualified certification technician.**

The electronics module houses the speed control, the lamp ballasts, the circuit breakers, as well as the motor capacitor.

1. Unplug the cabinet.
2. Remove the two 7/16" acorn nuts that secure the electronics module to the top of the cabinet, shown in Figure 6-4.
3. Pivot the module onto its back surface to access the electronic components within.

Figure 6-4

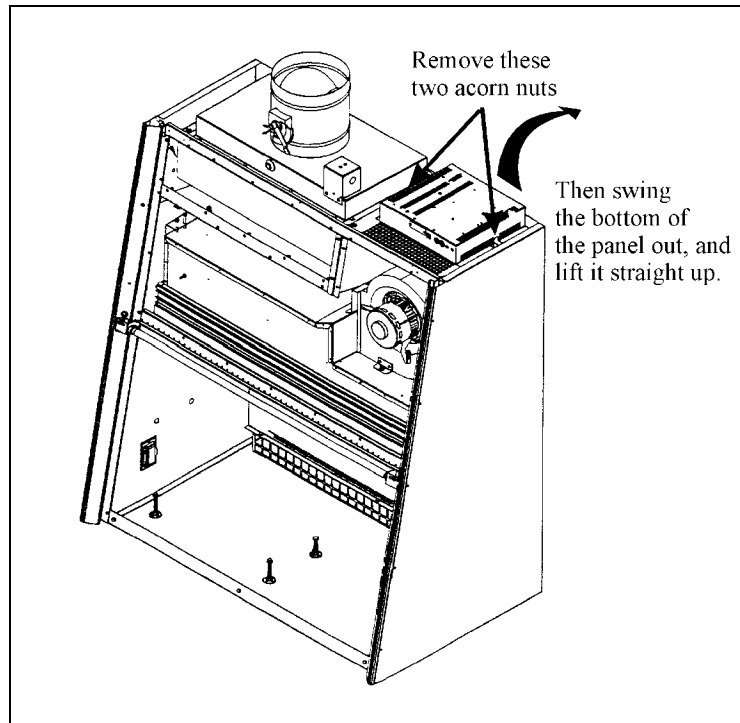

## Measuring Line and Motor Voltage



**Line and motor voltage contact points are high voltage connections. Use caution when measuring either voltage.**

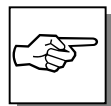

A VOLTAGE CONNECTOR CAN BE FABRICATED FROM COMMERCIALY AVAILABLE ELECTRONICS HARDWARE, OR ONE IS AVAILABLE TO QUALIFIED CERTIFIERS FROM LABCONCO CORPORATION. CONTACT LABCONCO'S PRODUCT SERVICE DEPARTMENT FOR FURTHER DETAILS.

1. Remove the access panel located on the front of the electronics module by removing the right hand Phillips screw, and loosening the left hand screw as shown in Figure 6-5. Pivot the panel out of the way.
2. Locate the voltage test points on the electrical panel. The test points are identified by Figure 6-6, shown below.
3. Using a voltmeter and probes, measure the desired voltage by connecting the voltmeter probes to the appropriate points.

**Figure 6-5**

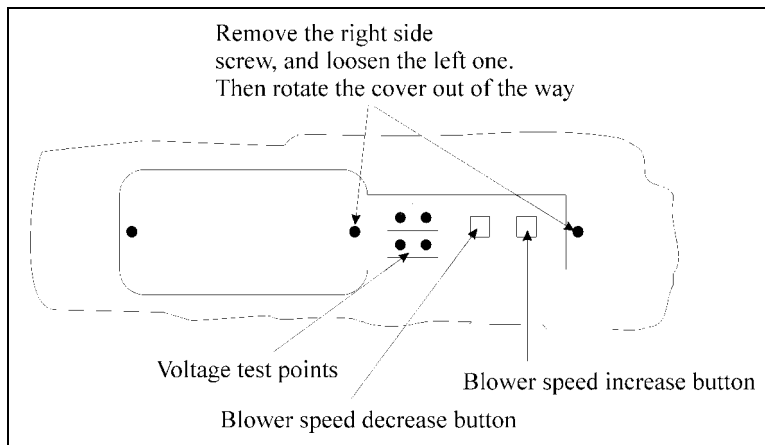

**Figure 6-6**

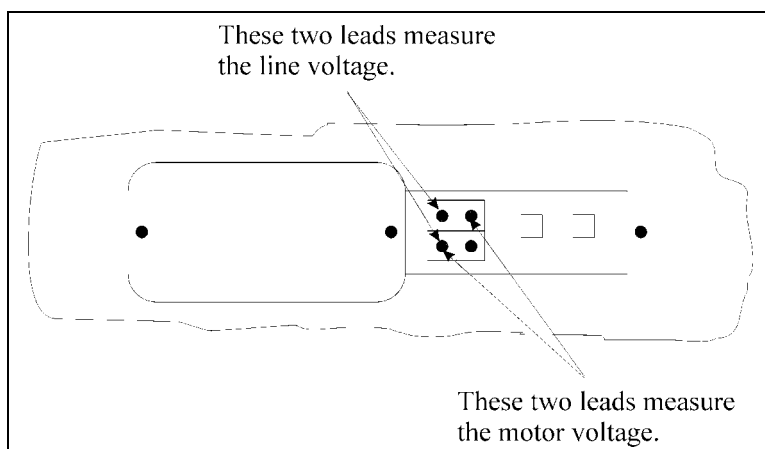

## Speed Control Adjustment

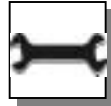

**The Purifier blower speed should only be adjusted by a qualified certification technician. Adjustment of the blower speed will affect the containment efficiency of the unit.**



**The Purifier's blower speed is adjusted and its setpoint is maintained by a solid state electronic circuit. There is no potentiometer as on traditional biosafety cabinets. The blower speed setting is adjusted and protected by an electronic interlock that must be released to reset the motor voltage.**

1. Remove the access panel located on the front of the electronics module by removing the right hand Phillips screw, and loosening the left hand screw as shown in Figure 6-5. Pivot the panel out of the way.
2. Locate the voltage test points on the electrical panel. The test points are identified by Figure 6-6, shown above.
3. Using a voltmeter and probes, measure the motor voltage by connecting the voltmeter probes to the appropriate points.
4. Shut the Purifier off.
5. While holding down the "alarm silence" button, turn the "System Power" switch on.
6. The blower will start, and the audio and visual alarm will operate in an alternating mode. The blower speed can now be adjusted.
7. The blower speed can be increased by pressing the button on the right; pressing the button on the left decreases the blower speed as shown in Figure 6-5.
8. Once the proper blower speed has been established by inflow and downflow testing, the new blower voltage can be programmed into the speed controller by depressing the "Alarm Silence" button again. The audio alarm will sound a single long tone, and then shut off, indicating the new voltage is properly programmed.

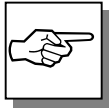

IF YOU WISH TO CANCEL THE NEW BLOWER VOLTAGE SETTING, SIMPLY TURN THE “SYSTEM POWER” SWITCH OFF BEFORE DEPRESSING THE “ALARM SILENCE” BUTTON. THIS WILL CANCEL THE NEW SETTING, AND RETURN THE SPEED CONTROLLER TO ITS PREVIOUS VALUE.

## Use of the Access Tube For DOP Testing

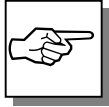

THE PURIFIER UTILIZES A UNIQUE ACCESS TUBE FOR SAMPLING THE UPSTREAM CONCENTRATION OF DOP FOR THE SUPPLY FILTER. IF AFTER READING THESE INSTRUCTIONS, YOU HAVE FURTHER QUESTIONS, PLEASE CONTACT LABCONCO'S PRODUCT SERVICE DEPARTMENT.



**The access tube may be surface contaminated. DO NOT access this line until the outside surface has been decontaminated. DOP scanning of the HEPA filters should only be performed by a qualified certification technician as part of the recertification procedure.**

1. Remove the work surface as shown in Figure 6-1.
2. Locate the access tubes on left side of the rear plenum wall, behind the towel catch.
3. Pull the tube toward the front of the unit. Remove the access tube's cover.
4. Using an appropriate photometer, connect the unit's upstream line to the access tube.
5. After completing the DOP test of the filters, replace the access tube cover, ensuring that it is sealed properly.
6. Replace the access tube, and the work surface.

## HEPA Filter Replacement



**The cabinet must be properly decontaminated before servicing the exhaust HEPA filter. The HEPA filters should only be serviced by a qualified certification technician. Following replacement of a HEPA filter, the cabinet MUST be recertified by a qualified certification technician.**

1. Unplug the cabinet.
2. Remove the front dress panel as shown in Figure 6-2.
3. Remove the sash pocket by loosening the two Phillips screws on the left side of the pocket. Support the sash pocket while removing the two screws on the right side of the sash pocket. Swing the sash pocket out and away from the unit as shown in figure 6-7.

**Figure 6-7**

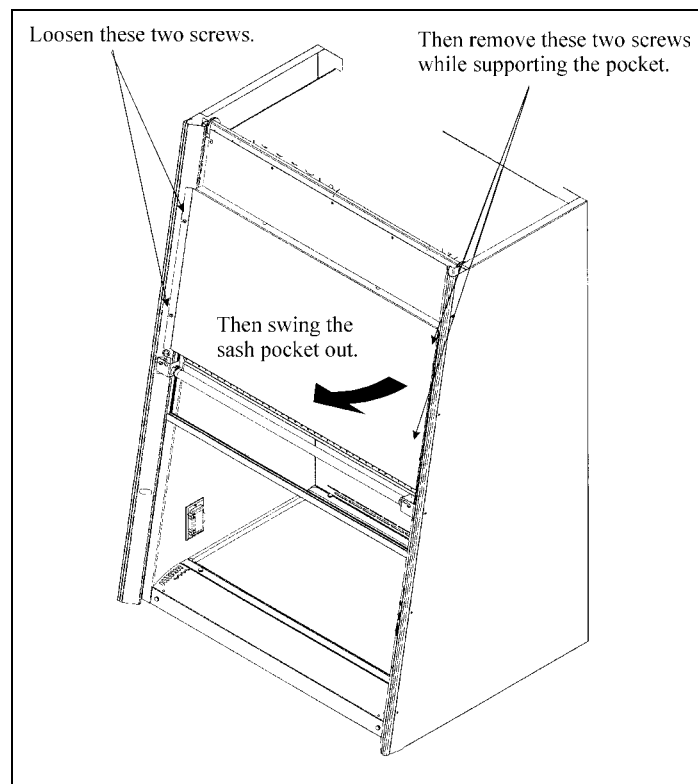



**To Remove the Supply HEPA Filter:**



**The supply HEPA filter is awkward to handle and heavy. Use appropriate lifting techniques to remove and handle it. Use two people to remove the filter if possible.**

1. Loosen and remove all of the Phillips screws on the blower chamber cover. Gently rock the cover, slide it to the left or right, and swing it out and away from the unit.
2. Using a 1/2 inch wrench, loosen the four locking bolts that contact each corner of the plenum box at least 1/2 inch, as shown in Figure 6-8.
3. Use a 1/2-inch socket or wrench to tighten the three plenum lift bolts located as noted in Figure 6-8. This will lift the plenum box off the supply HEPA filter.
4. Slide the supply HEPA filter straight out the unit.
5. With the HEPA filter removed, inspect the filter shelf for damage.

**Figure 6-8**

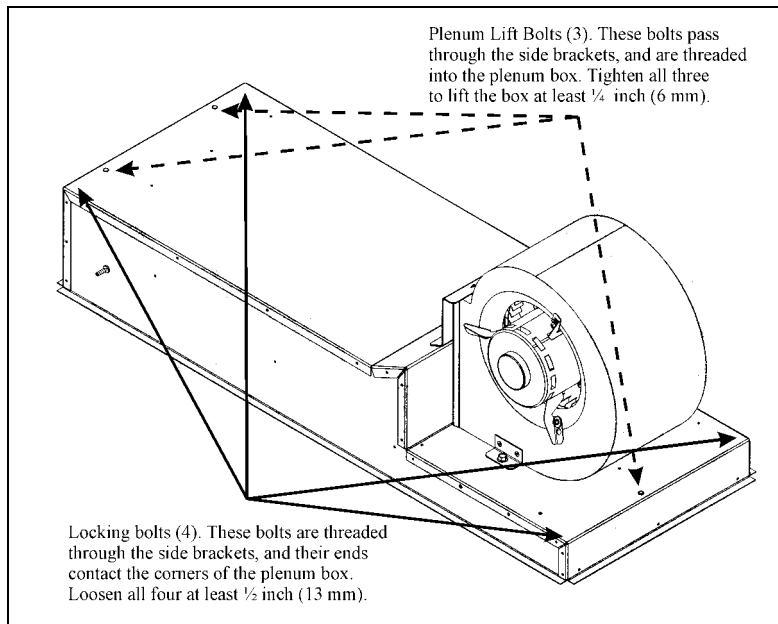

### **To Install a Supply HEPA Filter:**

1. Install a new supply HEPA filter by pushing it straight into the cabinet, ensuring that it is correctly oriented, and that the filter is centered on the filter shelf.
2. Use a 1/2-inch socket or wrench to sequentially loosen the three plenum lift bolts located as noted in Figure 6-8. When properly positioned, the plenum box will be aligned with the supply HEPA filter frame, and there will be an approximately 1/4 inch gap between the bottom of the plenum lift bolt head and the top of the lift bracket. This will allow the plenum box to properly seat as the filter gasket is compressed.
3. Using a 1/2-inch wrench, tighten the four locking bolts located at each corner of the plenum box, as shown in Figure 6-8 until the supply HEPA filter gasket is compressed to approximately 50% of its thickness.



**The locking bolts should only be tightened enough to ensure a proper seal of the supply HEPA filter. At maximum tightness, the supply filter's gasket should be compressed to 50% of its original thickness. NEVER tighten the locking bolts beyond this setting.**

### **To Remove the Exhaust HEPA Filter:**

1. Loosen and remove all of the Phillips head screws on the exhaust HEPA filter cover. Gently rock the cover and pull it away from the unit.
2. Using a 1/2 inch wrench, loosen the four exhaust filter clamping bolts located on the top of the unit, as shown in Figure 6-9. Loosen all of the bolts until the filter drops away from the top of the Purifier.
3. Slid the exhaust HEPA filter straight out of the unit.
4. With the exhaust filter out of the unit, inspect the filter for damage.

**To Install an Exhaust HEPA Filter:**

1. Slide the new exhaust HEPA filter all the way into the shelf.
2. Sequentially tighten the four exhaust filter clamp bolts as shown in Figure 6-9 until the exhaust filter gasket is compressed approximately 50%.



**The exhaust filter sealing bolts should only be tightened enough to ensure a proper seal of the exhaust HEPA filter. At maximum tightness, the exhaust filter's gasket should be compressed to 50% of its original thickness. NEVER tighten the bolts beyond this setting.**

3. Install the exhaust filter chamber cover, uniformly tightening the screws on the cover until the gasket has formed a proper seal.
4. Install the sash pocket.
5. Install the front dress panel.
6. Plug in the cabinet and have it recertified before use.

**Figure 6-9**

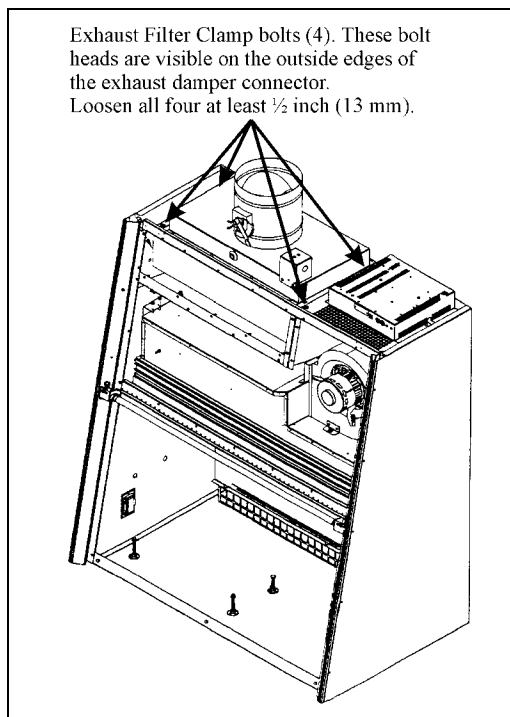

## Motor/Blower Maintenance and Replacement

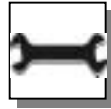

**The motor/blower should be serviced by a qualified certification technician.**

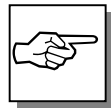

**The cabinet blower motor's bearings are sealed and require no lubrication. DO NOT attempt to lubricate them.**

### **To replace the Motor/Blower:**

1. Unplug the cabinet.
2. Remove the front dress panel as shown in Figure 6-2.
3. Remove the sash pocket as shown in Figure 6-8.
4. Loosen and remove all of the Phillips screws on the blower chamber cover. Gently rock the cover, slide it to the left or right, and swing it out and away from the unit.
5. Using a screwdriver, disconnect the motor ground wire from the blower housing.
6. Disconnect the motor leads from the wiring harness by pulling apart each of the 4 connectors.
7. Using a 1/2-inch wrench, remove the two upper and one lower blower mounting bolts, as shown in Figure 6-10.



**The motor/blower assembly is heavy. Handle with care.**

8. While supporting the blower assembly, pull the assembly straight out the plenum.
9. To replace the motor/blower assembly, reverse the above procedure.
10. Plug in the cabinet and have it recertified before use.

**Figure 6-10**

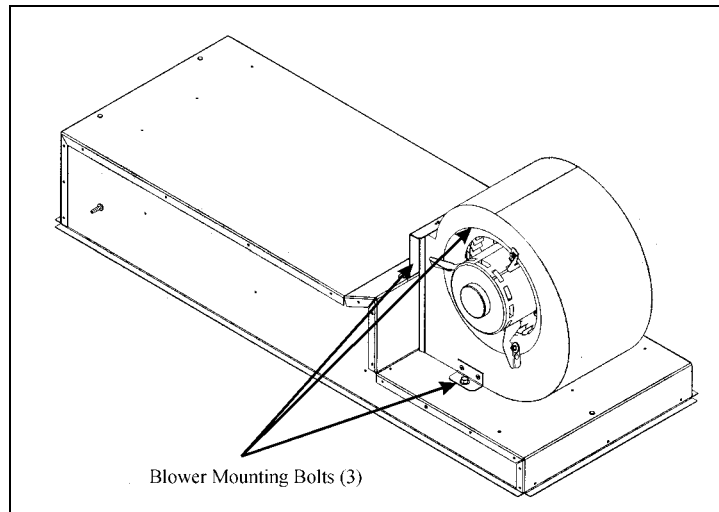

## Diffuser Removal



**The work area of the cabinet must be thoroughly disinfected before removing the diffuser. Before removing the diffuser, note its orientation. It can only be installed one way. Bending or distorting the diffuser may affect the airflow in the cabinet. Use care when handling it. When properly installed, the rear edge of the diffuser should rest on the diffuser support brackets located on the rear wall of the work area as shown in Figure 6-11.**

1. Shut off the Purifier and raise the sash to the full open position. Remove the sash pocket, as described in Figure 6-8.
2. Remove the fasteners located in the front edge of the supply HEPA filter shelf.
3. Carefully lower the diffuser. Remove it, by tilting the front edge down.
4. Install the diffuser plate by reversing the above steps.

Figure 6-11

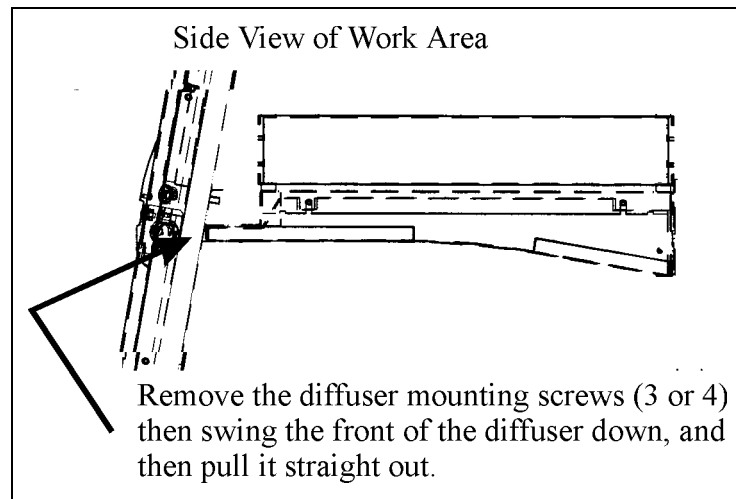

## Storage

If the Purifier cabinet is to be left unused for more than one month, the unit should be prepared for storage.



**The cabinet should not be stored in areas of excess humidity or temperature extremes. If the cabinet is moved during storage, it must be recertified before use.**

1. Close the sash completely and seal the bottom edge and the exhaust outlet with plastic sheeting.
2. Unplug the unit.
3. Ensure that the cabinet will not be moved or disturbed while in storage.

## Decontamination



**Gaseous decontamination should only be performed by trained personnel.**

The unique sash pocket of the Purifier allows for the gaseous decontamination of the entire interior of the cabinet, as well as the inside of the sash, and the outside

surface of the blower cover, an area which may possibly become contaminated during operation.

**To seal the Purifier follow these steps:**

1. Remove the front dress panel as shown in Figure 6-2. Place decontamination equipment inside the work area of the Purifier. Remove the sash stops from the lower front edge of the unit. Close the sash until it covers the lower edge of the unit.



**The outlets on the interior of the Purifier are energized as long as the Purifier is plugged in. Unplug the Purifier before decontamination equipment is plugged into these outlets.**

2. Seal the air inlet on the top of the cabinet. Ensure that all service valves and the drain valve are closed.
3. Using a flexible sealant, plug the area around the sash cables where they exit the top of the sash pocket.
4. Use duct tape to seal the outside edge of the sash pocket to the side panels.
5. Seal the upper and lower edges of the sash pocket using duct tape.
6. Seal the sides of the sash to the corner posts, and the sash handle to the lower front edge of the unit.
7. Close the exhaust damper completely.
8. Perform the decontamination as described in NSF Standard 49, Annex G.

## Your Next Step

After you understand the maintenance procedures, you are ready to proceed to *Chapter 7: Modifying Your Biosafety Cabinet*.





---

# CHAPTER 7

## MODIFYING YOUR BIOSAFETY CABINET

There are several ways to modify your Purifier for your individual requirements. These include the addition of a UV lamp, service fixtures or an intravenous (IV) bar.

### Installing a UV Lamp

All Labconco Purifier Delta Series Safety Cabinets are pre-wired for the installation of a UV lamp.

4-foot units require the installation of a UV lamp kit, consisting of the UV lamp, its ballast, and fasteners. The kit is part number 37450-00 for 115 Volt models, 37450-01 for 230 Volt units.

4'



**The UV lamp kit should be installed by a qualified electrician or certifier.**



**Completely surface decontaminate all interior work surfaces of the Purifier before beginning the installation of the UV lamp.**

4'

**To install the UV lamp kit do the following:**

1. Unplug the unit.
2. Using a 7/16-inch wrench or socket, remove the two acorn nuts that secure the electronics module to the top of the Purifier as shown in Figure 6-3.
3. Tilt the electronics module back to access the underside of the module.
4. Locate the fluorescent lamp ballast in the module. The UV lamp ballast mounts next to the fluorescent ballast.
5. Using the Phillips screws and locking nuts, secure the UV ballast to the enclosure as shown in Figure 7-1.
6. Wire the UV ballast into the wiring harness, following the wiring diagram located in Figure 7-1.
7. Raise the sash, and install the UV lamp by rotating the lamp pins into the sockets.
8. Lower the sash to fully closed position, plug in the unit, and turn the system power switch to the "UV" position. The UV lamp will illuminate.

Figure 7-1

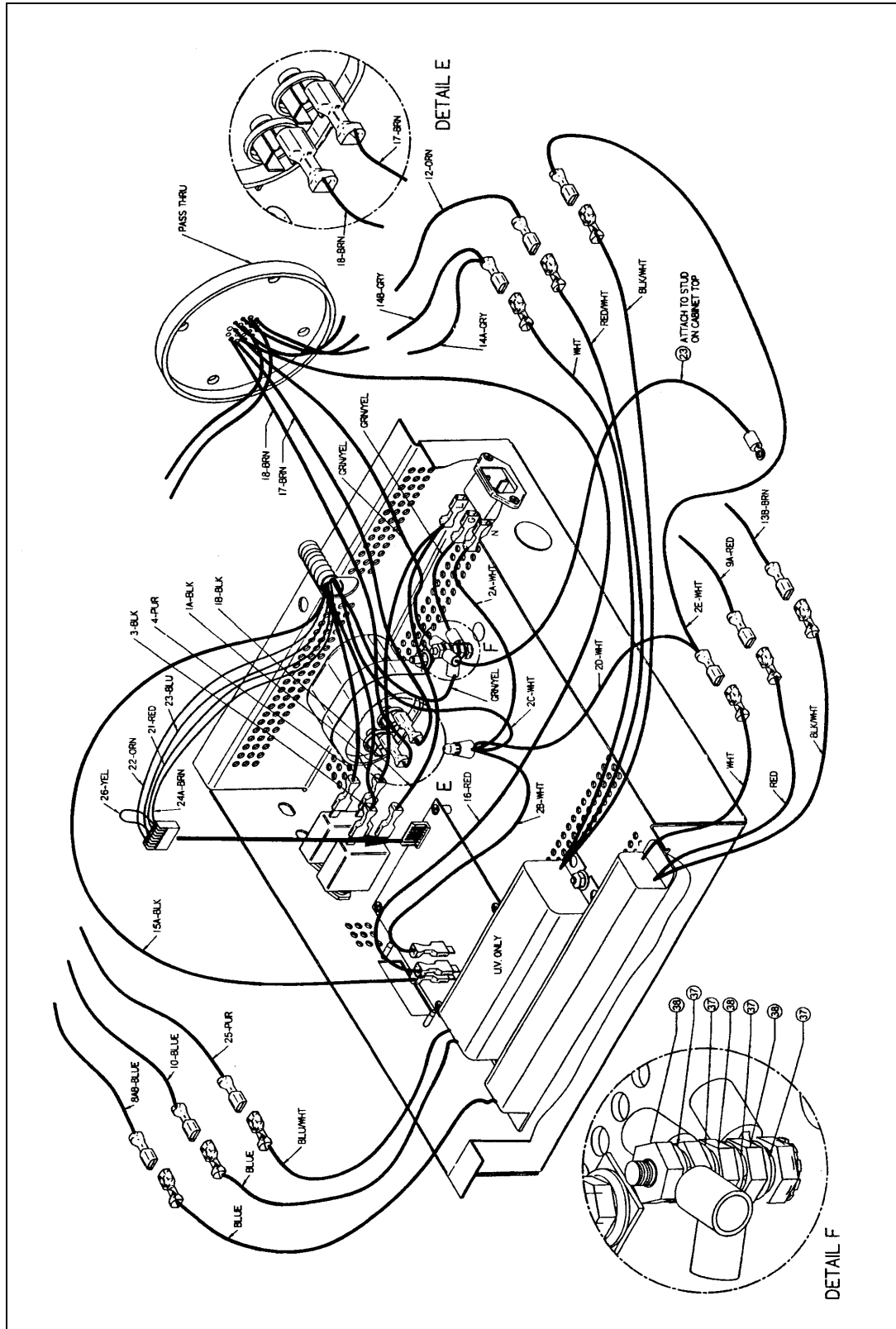

6'

6-foot units only require the installation of the UV lamp. The lamp is part number 12713-00.



**Completely surface decontaminate all interior work surfaces of the Purifier before beginning the installation of the UV lamp.**

6'

**To install the UV lamp kit do the following:**

1. Unplug the unit, and raise the sash to the full open position.
2. Install the UV lamp by pushing it into the left socket, and compress the socket, swinging it into the right lamp socket.
3. Lower the sash to fully closed position, plug in the unit, and turn the system power switch to the "UV" position. The UV lamp will illuminate.

## Installing Additional Service Fixtures



**Completely surface decontaminate all interior work surfaces of the Purifier before beginning the installation of the service valve.**

Additional service fixtures can be installed in any of the four available service fixture holes in both side walls. The service fixture kit is Labconco part number 36933-00. To install the service fixture:

1. Decide into which of the available locations you want to install the service fixture.
2. Remove the side panel on that side of the unit as shown in Figure 3-2.
3. Remove as much of the silicone sealant as possible from around the outside of the service fixture hole plug.
4. Placing a block of wood or plastic against the outside edge of the plug, and using a small hammer, *gently* tap the plug out of the hole.



**Do not use excessive force in attempting to remove the hole plug. Damage to the side wall of the cabinet could occur.**

5. Carefully remove any remaining sealant from both sides of the service fixture hole.
6. Using the Teflon tape supplied, wrap two to three turns of tape on the male pipe thread of the valve, and the tube fitting.
7. Put the threaded end of the fixture through the hole, orienting the valve as shown in Figure 3-7. Using the silicone sealant, apply a bead of silicone on the outside surface of the cabinet side, around the valve body. This will provide a pressure tight seal around the valve body. Place the two washers on the valve thread, then install the coupler. Holding the valve body in position, use a wrench or pliers to thread the coupling on until the valve is captured on the side panel.
8. Thread the tubing connector onto the coupling until it can no longer be turned by hand. Holding the coupling secure with a wrench or pliers, turn the tube fitting approximately one more revolution, using pliers or a wrench. Orient the tube fitting such that it is easy to access it with the incoming service tube.
9. Connect the service tube to the tube fitting by pressing the tube all the way into the fitting, turning the tubing nut until hand tight, and then approximately one more turn using pliers or a wrench.



**Make sure the service tubing does not obstruct the wiring or sash weights or cables.**

10. Make sure the service fitting in the Purifier is in the off position before pressurizing the service line. Once pressurized, check the valve body, the coupling, and the tube fitting for leaks. Tighten any leaking joints.
11. Reattach the side panel.

12. The valve is shipped with a white plastic index disc. This disc can be replaced with the orange or yellow disc supplied by unscrewing it and replacing it with the new one.

## Installing the IV Bar



**Completely surface decontaminate all interior work surfaces of the Purifier before beginning the installation of the IV bar.**

4'

1. Shut off the Purifier and raise the sash to the fully open position.
2. Remove the four black protective caps on the side walls and discard them.
3. Mount one of the IV brackets on the two studs on either side wall. Orient the bracket so that the center section of the bracket is offset away from the side of the Purifier side wall. Secure the bracket using the flat washers, lock washers, and acorn nuts as shown in Figure 7-2.
4. Slide the other bracket onto the IV bar, and install it to the side wall in the same position as the bracket on the other side wall, as shown in Figure 7-2.
5. Secure the end brackets by tightening all of the fasteners.

**Figure 7-2**

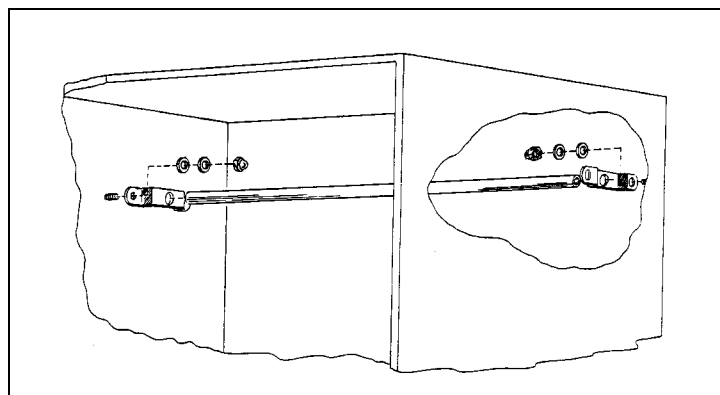

1. Shut off the Purifier and raise the sash to the fully open position.
2. Remove the four black protective caps on the side walls and discard them.
3. Mount one of the IV brackets on the two studs on either side wall. Orient the bracket so that the center section of the bracket is offset away from the side of the Purifier side wall. Secure the bracket using the flat washers, lock washers, and acorn nuts as shown in Figure 7-3.
4. Insert the center support brace on the IV Bar. Slide the other bracket onto the bar and install it to the side wall in the same position as the bracket on the other wall, as shown in Figure 7-3.
5. Secure the center support brace and the end brackets by tightening all of the fasteners.

6'

**Figure 7-3**

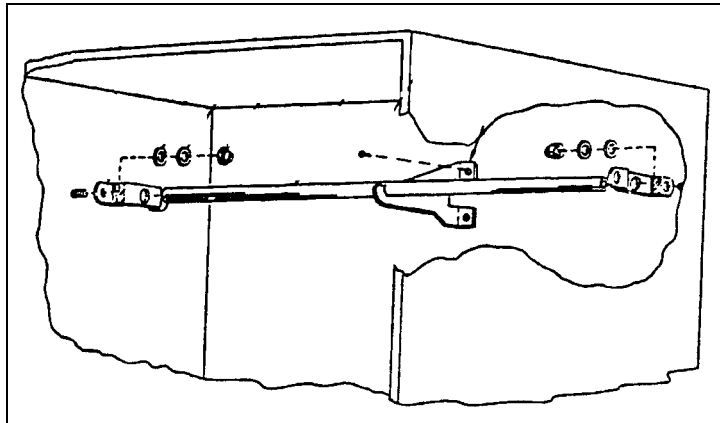

## Your Next Step

After you understand the maintenance procedures, you are ready to proceed to *Chapter 8: Troubleshooting*.





---

# CHAPTER 8

## TROUBLESHOOTING

Refer to the following table if your Purifier fails to operate properly. If the suggested corrective actions do not solve your problem, contact Labconco for additional assistance.

PROBLEM	CAUSE	CORRECTIVE ACTION
<b>Cabinet blower and lights won't turn on</b>	Unit not plugged into outlet	Plug the Purifier into appropriate electrical service.  Check connection to control box on top of unit.
	Circuit breakers tripped	Reset circuit breakers.
<b>Blower won't turn on but lights work</b>	Sash closed	Raise sash.
	Blower wiring is disconnected	Inspect blower wiring.
	Blower motor is defective	Replace blower motor.
<b>Cabinet blower turns on but lights don't work</b>	Lamp not installed correctly	Inspect lamp installation.
	Lamp is defective	Replace lamp.
	Lamp circuit breaker tripped	Reset the lamp circuit breaker.

<b>PROBLEM</b>	<b>CAUSE</b>	<b>CORRECTIVE ACTION</b>
<b>Cabinet blower turns on but lights don't work (cont.)</b>	Lamp wiring is disconnected	Inspect lamp wiring.
	Defective lamp ballasts	Replace lamp ballasts.
<b>Alarm sounds after the alarm system switch is released from 'Reset'</b>	Roof blower is off	Ensure that roof blower is working.
	Exhaust damper is improperly positioned.	Ensure that the exhaust damper is properly set by a qualified certifier.
	Remote blower is improperly sized	Confirm that the roof mounted blower meets the volume and pressure requirements in the Airflow Data Table.
	Mechanical failure of the exhaust system	Inspect the exhaust system.
	Obstruction in the exhaust system	Inspect the exhaust system.
	Leak or additional 'load' on the exhaust system	Inspect the exhaust system.
	Loading of the exhaust HEPA filter	Replace the HEPA filters.
<b>Slight increase in pressure reading</b>	HEPA filter loading	The pressure reading will steadily increase as the unit is used.
	Blockage of the return air slots or grille	Check all return air slots and grilles to ensure that they are not blocked or restricted.
	Blockage of the exhaust outlet	Ensure that the exhaust outlet is not blocked or restricted.
	Blockage or restriction under the work surface	Ensure that the plenum beneath the work surface is unobstructed.

PROBLEM	CAUSE	CORRECTIVE ACTION
<b>Contamination of work in the cabinet</b>	Improper technique or procedure for the biohazard cabinet	See “Use of the Cabinet” section in the manual.
	Restriction of the return air slots or grille – blockage of the exhaust outlet	Ensure that all return air slots, grilles and the exhaust outlet are unobstructed.
	External factors are disrupting the cabinet airflow patterns or acting as a source of contamination	See “Installation” section of this manual.
	Cabinet is out of adjustment/HEPA filter(s) are defective	Have cabinet recertified.



---

# APPENDIX A

## PURIFIER

## COMPONENTS

Illustration A-1 indicates the location of the following service parts

### Purifier Replacement Parts

Item	Quantity	Part No.	Description
1	1	3734000	Side Panel, R.H.
2	1	3734001	Side Panel, L.H.
3	1	5950000	Exhaust HEPA Filter 4-foot
3A	1	5960000	Exhaust HEPA Filter 6-foot
4	1	3731100	Motor/Blower Assembly, 115 VAC 4-foot
4A	1	3731101	Motor/Blower Assembly, 115 VAC 6-foot
4B	1	3757100	Motor/Blower Assembly, 100 VAC 4-foot
4C	1	3757101	Motor/Blower Assembly, 100 VAC 6-foot
4D	1	3751900	Motor/Blower Assembly, 230 VAC 4-foot
5	1	1211200	Motor, 115 VAC 4- and 6-foot
5A	1	1210503	Motor, 100 VAC 4-foot
5B	1	1210501	Motor, 100 VAC 6-foot
5C	1	1210502	Motor, 230 VAC 4-foot
6	1	3739401	Supply HEPA Filter 4-foot
6A	1	3739402	Supply HEPA Filter 6-foot
7	1	9721902	Lamp, Fluorescent, 4-foot
7A	1	1278400	Lamp, Fluorescent, 6-foot
8	1	1271300	Lamp, UV, 4-foot (not shown)
8A	1	1231900	Lamp, UV, 6-foot (not shown)
9	2	1287900	Receptacle Cover

A-1

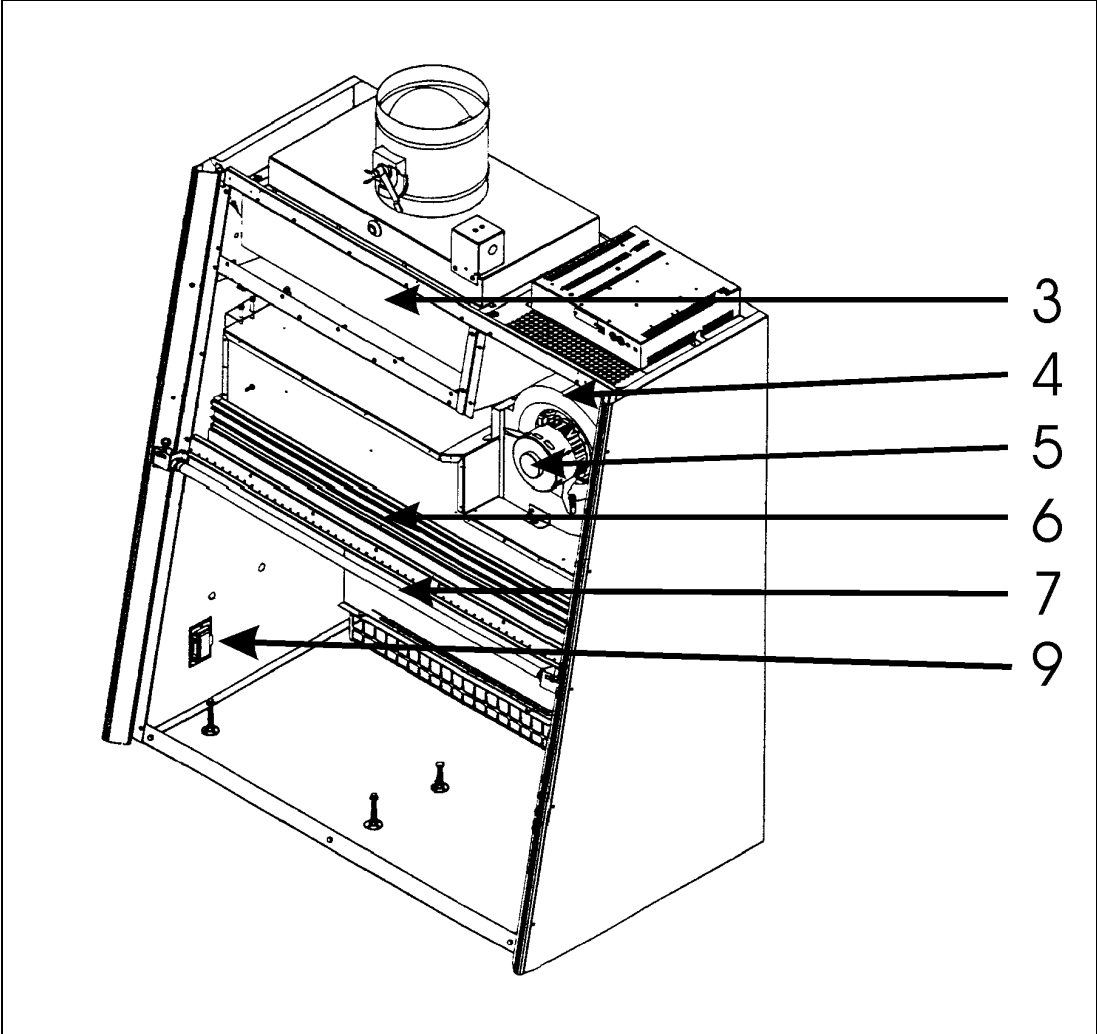

---

# APPENDIX B

# BIO SAFETY CABINET

# DIMENSIONS

B-1

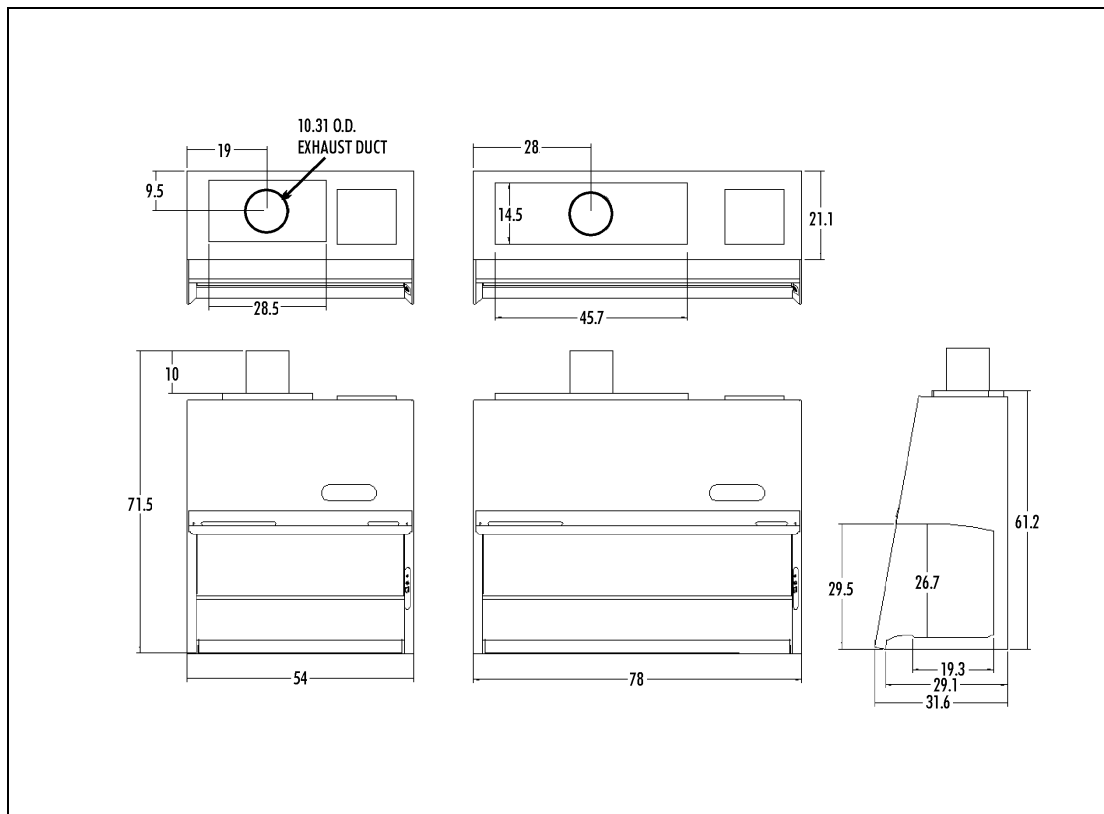





---

# APPENDIX C

## BIOSAFETY CABINET

### SPECIFICATIONS

#### Electrical Data

Cabinet Model	Electrical Requirements
36210-10 to -09	115 VAC – 60 Hz, 1 Phase – 12 Amps
36214-00 to -09	115 VAC – 60 Hz, 1 Phase – 12 Amps

Cabinet Model	Electrical Requirements
36210-10 to -19	100 VAC – 50/60 Hz, 1 Phase – 12 Amps
36214-10 to -19	100 VAC – 50/60 Hz, 1 Phase – 12 Amps

Cabinet Model	Electrical Requirements
36210-20 to -29	230 VAC – 50/60 Hz, 1 Phase – 7 Amps

#### Motor Specifications

Cabinet Model	Electrical Requirements
36210-00 to -09 36214-00 to -09	115 VAC – 60 Hz, 3.8 Full Load Amps 1/3 H.P. 1625 RPM Automatic Thermal Protection

Cabinet Model	Electrical Requirements
36210-10 to -19	115 VAC – 50/60 Hz, 3.9 Full Load Amps 1/3 H.P. 1625 RPM Automatic Thermal Protection

<b>Cabinet Model</b>	<b>Electrical Requirements</b>
36214-10 to -19	115 VAC – 50/60 Hz, 6 Full Load Amps 1/2 H.P. 1625 RPM Automatic Thermal Protection

<b>Cabinet Model</b>	<b>Electrical Requirements</b>
36210-20 to -29	230 VAC – 50/60 Hz, 1.9 Full Load Amps 1/3 H.P. 1625 RPM Automatic Thermal Protection

### **Environmental Conditions**

- Indoor use only.
- Maximum altitude: 6562 feet (2000 meters).
- Ambient temperature range: 41° to 104°F (5° to 40°C).
- Maximum relative humidity: 80% for temperatures up to 88°F (31°C), decreasing linearly to 50% relative humidity at 104°F (40°C).
- Main supply voltage fluctuations not to exceed ±10% of the nominal voltage.
- Transient overvoltages according to Installation Categories II (Overvoltage Categories per IEC 1010). Temporary voltage spikes on the AC input line that may be as high as 1500V for 115V models and 2500V for 230V models are allowed.
- Used in an environment of Pollution degrees 2 (i.e., where normally only non-conductive atmospheres are present). Occasionally, however, a temporary conductivity caused by condensation must be expected, in accordance with IEC 664.

C-1

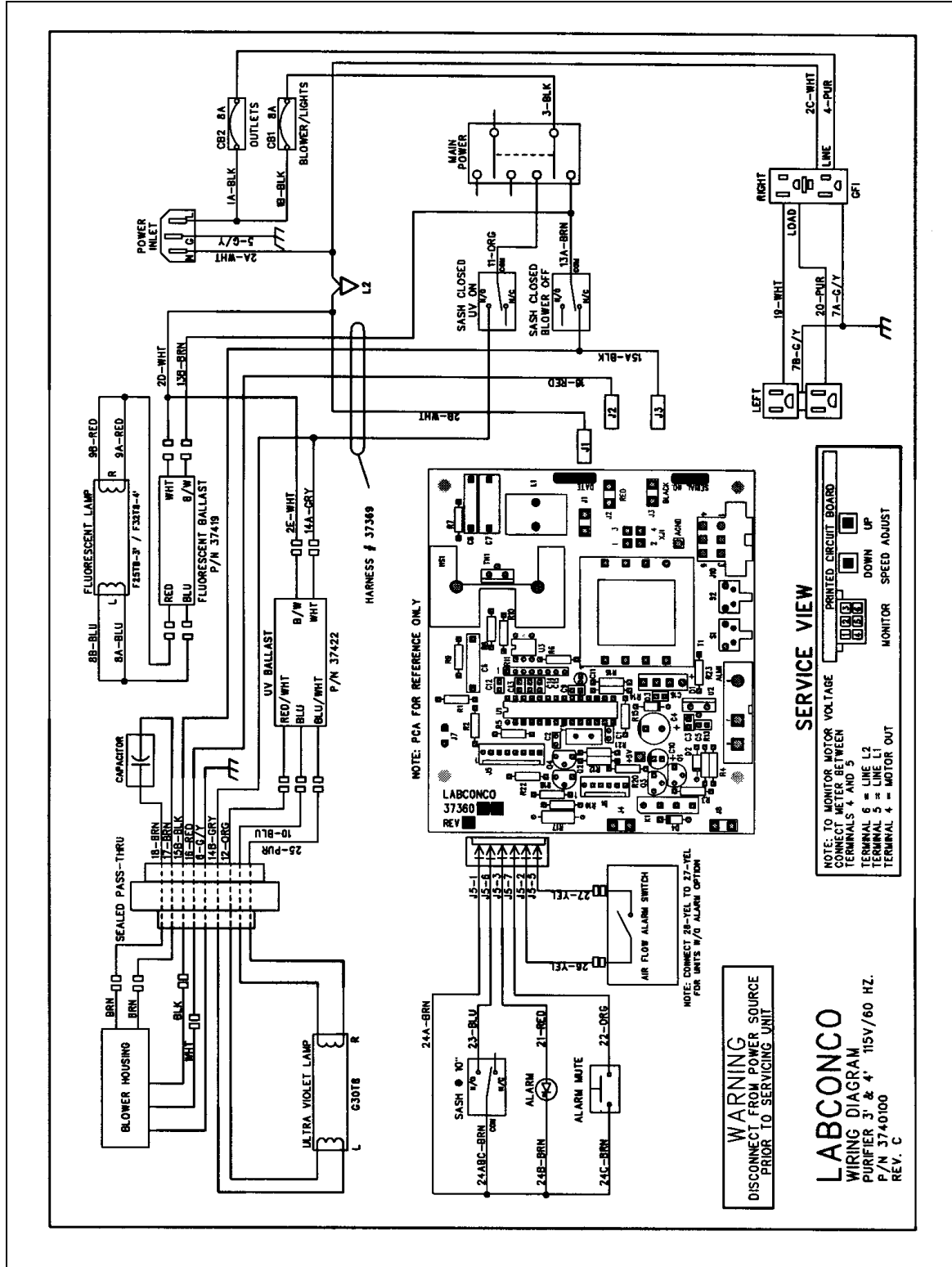

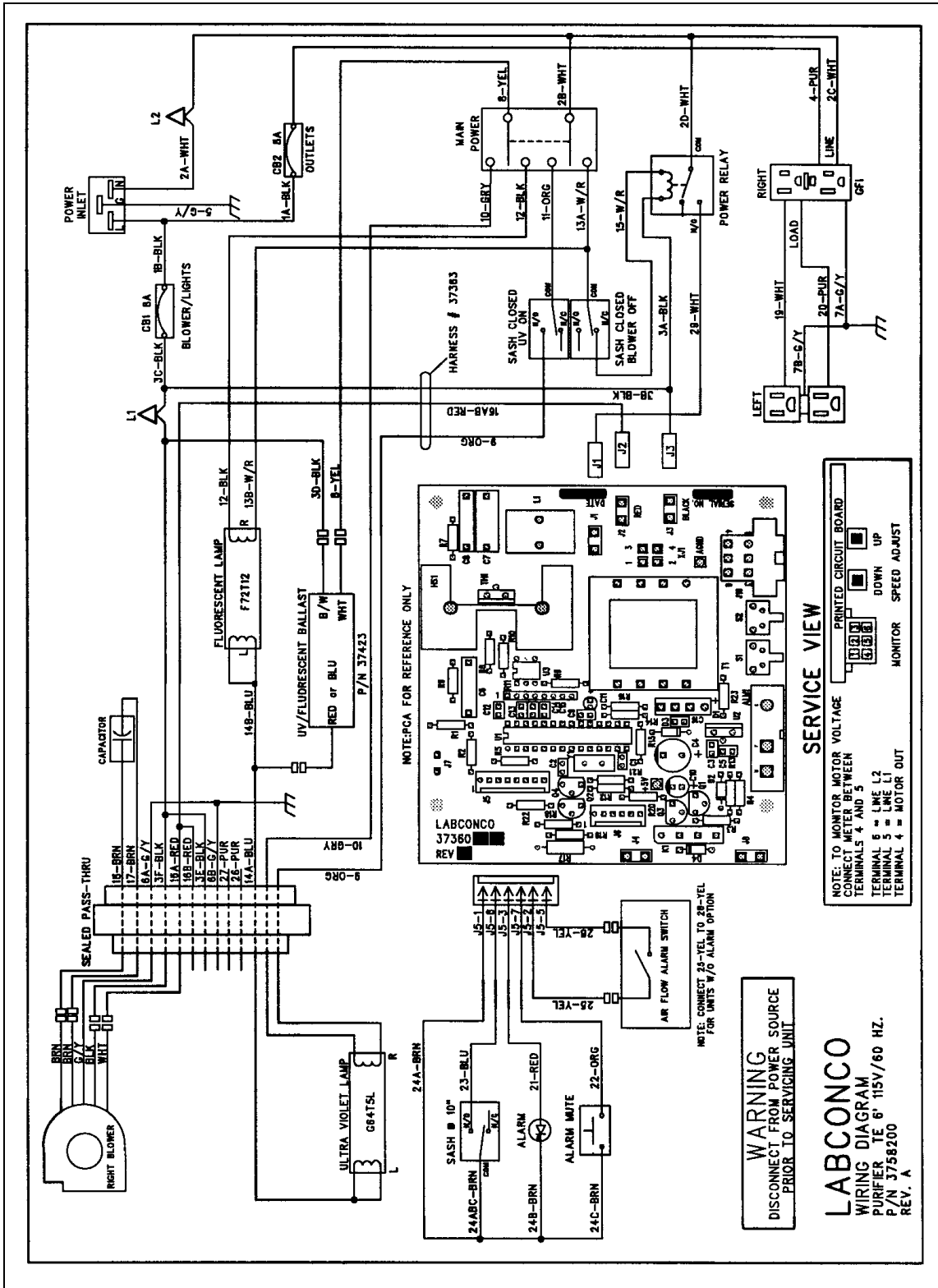

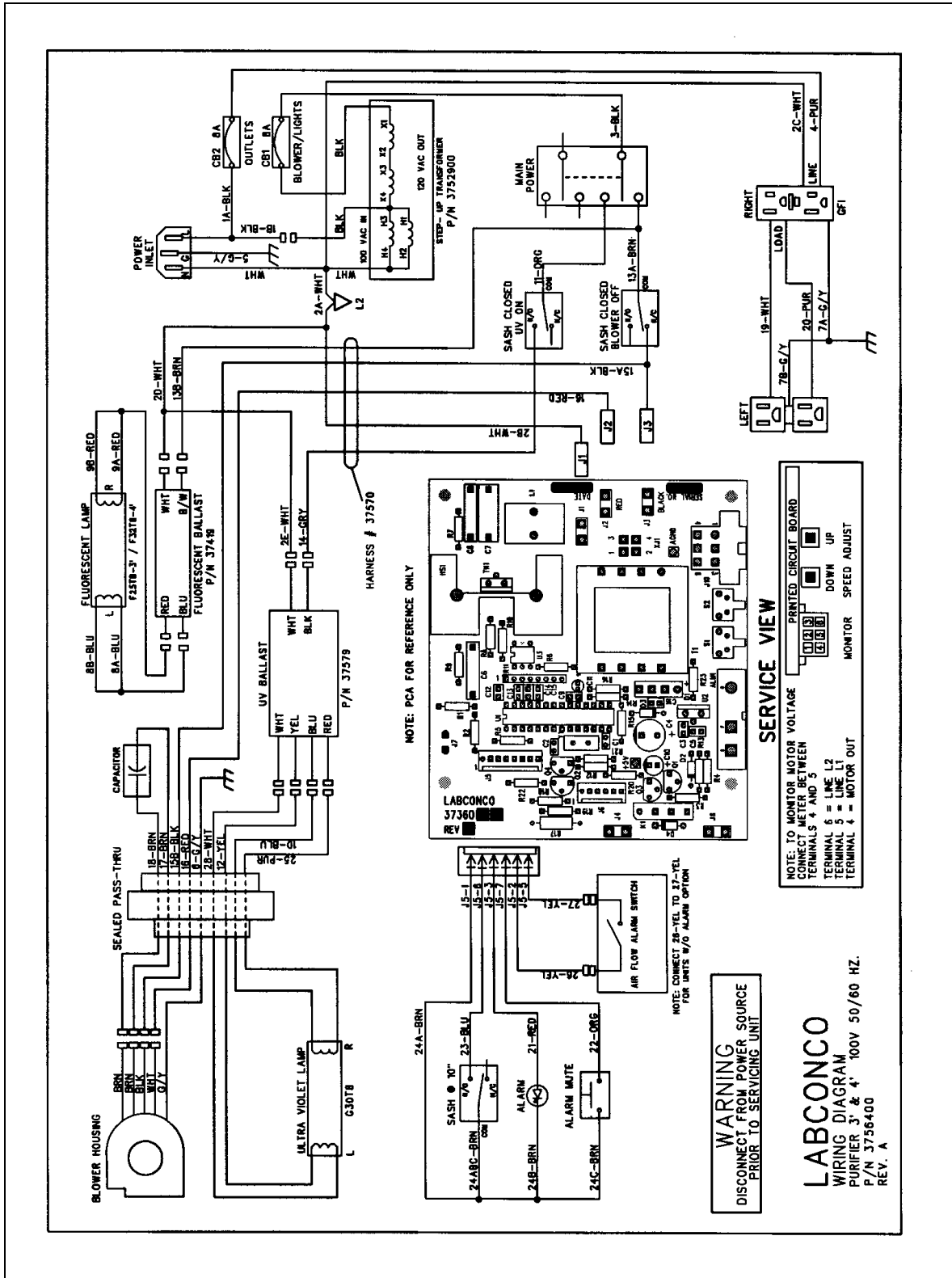

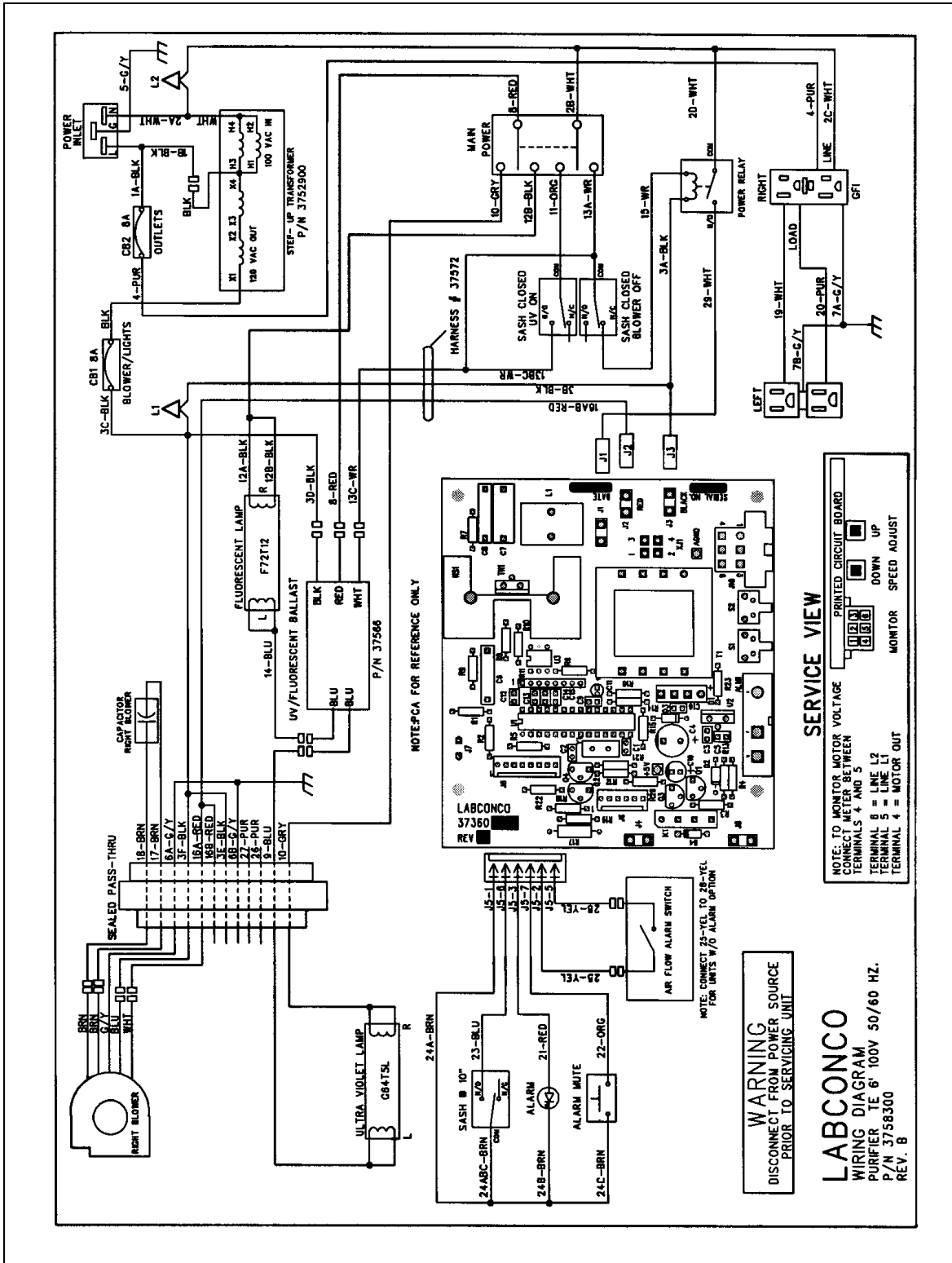

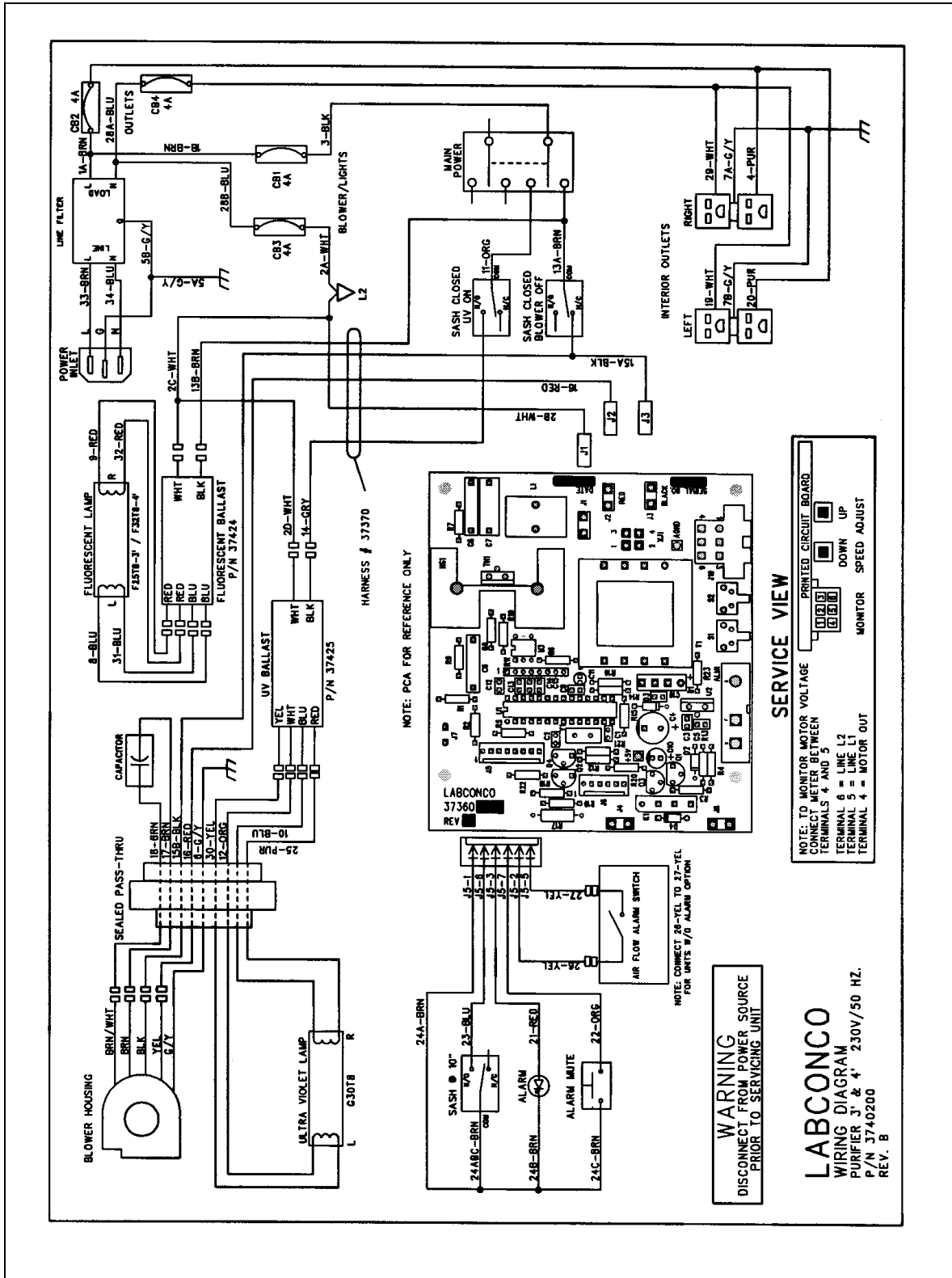





---

# APPENDIX D

## PURIFIER

### ACCESSORIES

#### Safety Orange Air Foil

Bold orange color cautions the operator to avoid placing materials in this area where airflow is critical. The air foil is epoxy-coated stainless steel and may be factory installed or retrofitted on site. Contact Labconco at 800-821-5525, 816-333-8811 or [labconco@labconco.com](mailto:labconco@labconco.com) for ordering information.

#### Base Stands

Epoxy-coated steel, adjust in 1-inch increments to provide a working height from 30 to 38 inches (29 ¼ inches deep x 27 ½ to 34 inches high). NSF tested and approved for use with the Purifier. ADA compliant.

Catalog #	For use with	Width	Shipping Weight
37304-00	4-foot Purifier Delta Series	50 1/2" (128 cm)	82 lbs. (37 kg)
37306-00	6-foot Purifier Delta Series	74 1/2" (189 cm)	100 lbs. (45 kg)

## Service Valve Kit (# 37475-00)

Includes serrated hose tip valve with quarter turn handle, hardware and instructions for plumbing to services mounts on left or right side interior. All cabinets are factory prepared to accept up to 4 fixtures. Shipping weight 4 lbs. (2 kg).

## Ultraviolet Lamp Kits

Includes 254 nm UV lamp. Kit # 37450-00 also includes a 115 volt ballast.

Catalog #	For use with	Shipping Weight
37450-00	4-foot Purifier Delta Series	5 lbs. (2.3 kg)
37450-01	6-foot Purifier Delta Series	3 lbs. (1.4 kg)

## IV Bar Kits

Bar supports intravenous solution bottles and bags. Kits include IV bar, mounting hardware, and four hangers.

Catalog #	For use with	Shipping Weight
37455-01	4-foot Purifier Delta Series	4 lbs. ( 1.8 kg)
37455-02	6-foot Purifier Delta Series	6 lbs. (2.7 kg)

## **Remote Blower (# 36635-00)**

24 5/16" wide x 21 1/2" deep x 22 3/8" high. Motor/blower shall be wired for operation on 230/460 volts, 3 phase, 60 Hz, 5.8/2.9 amps AC. The 2 hp motor shall be TEFC-type (totally enclosed fan cooled). Blower shall be belt driven with an adjustable sheave. Belt shall have a self-adjusting gravity tightener. Pillow block bearings shall be factory lubricated and sealed. Impeller shall be constructed of phenolic-coated steel. Blower shall have a dry powder epoxy-coated base and weathercover with vent holes. An integral damper assembly shall prevent backdrafts from flowing down through the ductwork, disturbing the airflow within the cabinet. Blower transition adapter inlet shall be 12 1/4" OD and shall be sized to accept 12" nominal diameter PVC duct. Blower transition adapter outlet shall be sized to accept 12" nominal diameter PVC duct. Shipping weight 100 lbs. (45 kg).

## **Ergonomic Chair with Armrests (# 37440-00)**

Designed to Biosafety Guidelines. Lab chair has 6-way articulating seat and back control for personalized adjustment. Pneumatic mechanism adjusts seat height from 18 1/4" to 25 3/4". Five-leg black reinforced composite base rests on 2" ball bearing casters. Aluminum support ring. Removable arm rests. Black vinyl upholstery. Shipping weight 35 lbs. (15.9 kg).

## **Adjustable Footrest (# 37460-00)**

Elevates feet and permits angle repositioning while in use. 18 1/2"w x 11 1/2"d x 8"h. Shipping weight 6 lbs. (2.7 kg).

---

# APPENDIX E

## QUICK CHART FOR

### THE DELTA TOTAL

### EXHAUST PURIFIERS

Model	36210	36214
Type	B2	B2
Sash Height (inches)	8	8
NSF Listed Downflow (FPM)	50-60	50-60
Sash Open Area (ft <sup>2</sup> )	2.69	4.03
*Direct Read NSF Listed Inflow (FPM)	100-110	100-110
*Total Exhaust Volume (CFM)	743-771	1111-1151
Exhaust Alarm Setting Volume (CFM)	730	1091
Approximate Settings for new Filters		
Motor Voltage	96-99	85-88
Mag Gauge Reading	0.8-1.1	0.8-1.1
Supply Air Volume Displacement (CFM)	475	708
Number of Laskin Nozzles Needed	1	1
Supply HEPA Filter Dims. (in.)	48x18x3	72x18x3
Exhaust HEPA Filter Dims (in.)	30x18x6	48x18x6
Motor HP	1/3	2 ea. 1/3
Speed Winding Used	High	High
Capacitor (uF, Volts)	15	15
Fluorescent Light(s)	F32T8/ TL741	F72T12/CW
UV Light(s)	G30T8	G64T5L/CB
Secondary Inflow Method Data		
Sash Height (in.)	2.97	1.99
Distance Between Points	4.05	4.03
Number of Test Points	11	17
Purifier Correction Factor	1.17	1.23



---

# APPENDIX F

## REFERENCES

Many excellent reference texts and booklets are currently available. The following is a brief listing:

*Primary Containment for Biohazards: Selection, Installation and Use of Biological Safety Cabinets.* September 1995. U.S. Department of Health and Human Services, Public Health Service, Centers for Disease Control and Prevention and National Institutes of Health.

*Biosafety in Microbiological and Biomedical Laboratories.* 4th Edition, May 1999. U.S. Department of Health, Education, and Welfare, National Institutes of Health, Division of Safety, Bethesda, MD 20892.

*Biosafety in the Laboratory.* 1989. National Research Council, National Academy Press, Washington, D.C.

*Laboratory Safety: Principles and Practices.* 2nd Edition 1995. American Society for Microbiology, Washington, D.C.

*National Sanitation Foundation Standard Number 49 for Class II (Laminar Flow) Biohazard Cabinetry.* 1992, Ann Arbor, Michigan.

*ASHP Technical Assistance Bulletin on Handling Cytotoxic and Hazardous Drugs.* 1990. American Society of Hospital Pharmacists. American Journal of Hospital Pharmacy. 47: 1033-1049.

*The Foundations of Laboratory Safety.* 1990. Stephen R. Rayburn. Springer-Verlag, New York.

*Formaldehyde Decontamination of Laminar Flow Biological Safety Cabinets.* U.S. Department of Health, Education, and Welfare, National Institutes of Health, Division of Safety, Bethesda, MD 20892.

**Websites of Interest:**

*www.absa.org*

*www.cdc.gov*



**DECLARATION OF CONFORMITY**

Application Council Directive(s): 73/23/EEC, 89/336/EEC

Standard(s) to which conformity is declared: EN61010, EN55014, EN55104

Manufacturer's Name: Labconco Corporation

Manufacturer's Address: 8811 Prospect Avenue  
Kansas City, MO 64132 USA

Importer's Name: See Shipping/Customs Documents\*

Importer's Address: See Shipping/Customs Documents for your equipment

Type of Equipment: Laboratory Equipment

Model No.: Purifier Delta Series Biological Safety Cabinets  
36205-24 3 Ft. Wide  
36209-24 4 Ft. Wide  
36213-24 6 Ft. Wide

Serial No.: Various – See Individual Declaration

Year of Manufacture: 2000 and Subsequent

I, the undersigned, hereby declare that the equipment specified above conforms to the above Directive(s) and Standard(s).

See individual Declaration of Conformity which will be signed by the importer for your country.

Place: \_\_\_\_\_  
(Signature)

Date: \_\_\_\_\_  
(Full Name)

\_\_\_\_\_  
(Position)

\*An individual version of this declaration is included with your shipping/customs documentation.

For more information, please contact us:

[ExpotechUSA](#)  
[10700 Rockley Road](#)  
[Houston, Texas 77099](#)  
[USA](#)

[281-496-0900 \[voice\]](#)

[281-496-0400 \[fax\]](#)

E-mail: [sales@expotechusa.com](mailto:sales@expotechusa.com)

Website: [www.ExpotechUSA.com](http://www.ExpotechUSA.com)