

ISO 9001
CERTIFIED

shindaiwa

OWNER'S AND OPERATORS MANUAL

SOUND-PROOF
DIESEL ENGINE GENERATOR

DGA20E



CAUTION

Do not operate the equipment before you have read and understood the instructions for use.



Table of Contents	Page
1. Safety Guidelines	1
2. Specifications	5
2-1. Data	5
2-2. Ambient Condition	6
3. Use	6
4. Parts	6
4-1. Outer and Main Components	6
4-2. Operation Panel	7
4-3. Output Panel	8
5. Equipment	9
5-1. Monitor Lamp	9
5-2. Meters	11
5-3. Fuel Line Changeover Valve (3-Way Valve)	16
6. Transportation & Installation	17
6-1. How to transport	17
6-2. Installation	18
7. Connecting load	19
7-1. Select Load Cable	19
7-2. Connecting Load Cable	20
7-3. ELCB and Grounding	21
8. Initialization and Pre-check	24
8-1. Engine Oil	24
8-2. Coolant / Water	25
8-3. Fan Belt	27
8-4. Fuel	27
8-5. Fuel, Oil and Coolant Leakage	28
8-6. Battery	29
9. Operation	30
9-1. Initialization and Preparation	30
9-2. During Operation	32
9-3. Stopping	32
9-4. Protection Feature	33
9-5. Connect to External Fuel Tank	34
10. Check and Maintenance	35
11. Long Term Storage	42
12. Troubleshooting	43
13. Generator Circuit Diagram	46
14. Engine Circuit Diagram	47

Introduction

Thank you for purchasing Shindaiwa Sound Proof Diesel Engine Generator.

- This user manual was created to ensure the safe operation of this equipment. Therefore, the manufacturer of this equipment strongly recommends that the user follow the instructions herein, to avoid unnecessary accidents and repairs.
- Please operate this equipment after thoroughly reviewing and understanding the contents of this manual.
- Please attach this manual, if the equipment will be sub-leased.
- Please store this manual near the equipment for easy reference.

- **Following convention will be used throughout the manual to indicate the degree of cautions.**

 Danger	<i>Can cause serious injuries or death.</i>
 Caution	<i>Can cause minor injuries or damage to the equipment or other properties.</i>
<Caution>	Other types of caution

- Even some of the items noted in 『 **Caution**』 may lead to serious injuries. Please read all item and follow all the safety guidelines.

1 Safety Guidelines



Danger : Suffocation from exhaust fume

- Exhaust fume from the engine contains many elements harmful to human. Do not operate this equipment in poorly ventilated area, such as inside a room or in a tunnel.



Danger : Electric Shock

- Do not insert metal objects (such as pin or wire) into plug-in receptacles.
- Do not touch wiring or electric parts inside the equipment during operation.
- Ground the every grounding terminal to the earth as set in the manual. If even one of all is unconnected by mistake or accident, it will be much more dangerous for human than the NO-RELAY case, because leaking current inevitably goes through the body.
- Even when the ELCB in the load is grounded to the earth, be sure to connect the terminal of bonnet in the equipment.
- Be sure to check the resistor value of the equipment periodically so that you can avoid the electric shock caused by electric leakage
- Before connecting or disconnecting a load cable from output receptacles, always turn the circuit breaker to OFF position.

- Before performing any equipment check or maintenance, stop the engine, and remove the engine key. A person performing the maintenance should always keep the key.

 **Danger : Injuries**

- Close all doors and place locks during operating this equipment, to avoid injuries by unintentionally touching cooling fan and fan belt.

 **Caution : Suffocation from exhausting fume**

- Do not point the exhaust fume toward pedestrians or building.

 **Caution : Injuries to eye and skin**

- Battery fluid contains diluted sulfuric acid. Avoid contact with eyes, skin or on clothing. If the acid comes in contact, especially with eyes, flush with a lot of water, and contact your physician immediately.

 **Caution : Explosion**

- Do not use the equipment or charge the battery, in the case the battery fluid level is lower than the LOWER level.
- Battery may emit some combustible gas, so keep it away from fire and sparks.

 **Caution : Fire**

- The equipment uses Diesel Oil as a fuel. When refueling, always stop the engine and keep away from fire. Moreover, always wait until the engine cools down before refueling.
- Always wipe any drip of Diesel fuel or lubrication oil. Do not use this equipment when a leak is found. Repair the equipment before use.
- Temperature around muffler and exhaust can get extremely high. Keep any inflammable items (such as fuel, gas, paint, etc.) away from the equipment.
- Always operate this equipment on flat surface and, at least 1 meter away from any objects (wall, box, etc.).
- Do not connect AC output to any indoor wiring.
- Always wait until the equipment cools down, before placing any covering materials for storage.

 **Caution : Burns**

- Never open the radiator cap during operation or just after engine stops as hot vapor may belch out.
- Do not touch the engine and muffler during operation and immediately after stopping the equipment, for the temperature can reach extremely high.

- When checking engine oil or changing oil, always stop the engine, and wait until the engine cools down. If you open either the oil gauge or the oil plug during operation, hot oil may cause some injury.



Caution : Injuries

- When lifting the equipment, always use a lift hook. Do not lift a handle, for it may cause equipment to drop due to handle breaking off.
- Always place the equipment on a flat and stable surface, to keep the equipment from sliding.
- When starting the engine, turn off the connected equipment and set the circuit breaker to OFF position.
- Do not move the equipment during operation.
- When performing equipment check and maintenance, always stop the engine.
- Do not operate the equipment, if the equipment is being modified or if the parts are removed.

■ Location of Warning labels

When warning label becomes unreadable or damaged, place new label at the appropriate location as specified in the following figure. When ordering the label, use the following part numbers.

- | | |
|-----------------------------|------------------|
| 1. Injuries | (No.19402-00210) |
| 2. Caution (coolant) | (No.19402-00295) |
| 3. Safety Precaution | (No.19402-00306) |
| 4. Caution (Electric Shock) | (No.19402-00215) |

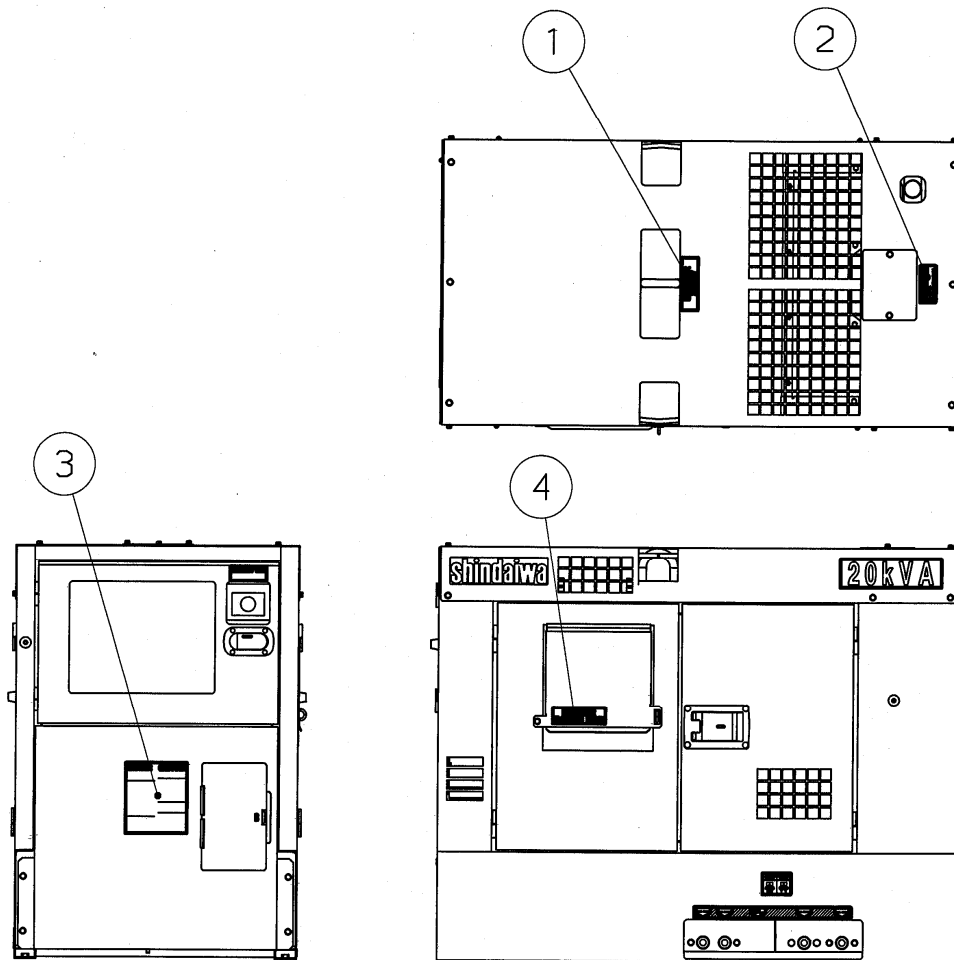

2 Specifications

2-1. Data

		Unit	DGA20E
Generator	Generating Method	-	Rotating Filed, Brushless 3-Phase Synchronous Generator
	Rated Output	kVA	20
		kW	16
	Rated Voltage	V	415
	Rated Current	A	27.8
	Rated Frequency	Hz	50
	Rated Speed	min ⁻¹	1500
	Phase & Wiring	-	3-Phase 4-Wire
	Power Factor	%	80
	Insulation Class	-	F
	Exciting Method	-	Self Excitation(Brushless)
	Poles	-	4
Engine	Method	-	Vertical, Water-cooled 4-Cycle, Diesel Engine
	Model No.	-	Isuzu BV-4LE1
	Cylinder-bore x stroke	mm	4 - 85 x 96
	Continuous Rated Speed	kW{PS}	19.1{26}
		min ⁻¹	1500
	Displacement	L	2.179
	Combustion Method	-	Swirl Chambered
	Cooling Method	-	Water-cooling radiator
	Lubricating	-	Trochoid pump, force-feed lubrication
	Starting	-	Starter Motor
	Fuel	-	Diesel
	Oil	-	SAE Class CD or higher
	Fuel Tank Capacity	L	78
	Lubricant Volume	L	8.8(including filter 0.4 L)
	Coolant Volume	L	8.2(including sub-tank 0.9 L)
	Starter Motor Cap.	V-kW	12-2.0
	Alternator Cap.	V-A	12-20
Battery	-	75D31R	
Dimension	Length	mm	1440
	Width	mm	780
	Height	mm	1140
	Dry Weight	kg	699
	Installed Weight	kg	789

2-2. Ambient Condition

Be sure to use the equipment under the following ambient condition range. Otherwise the condition may cause damage, insufficient output or durability shortage to the equipment.

- Ambient : Temperature: from -15 to 40 degree Celsius
- Relative : Humidity: less than 80%
- Altitude : Less than 300m

3 Use

- Power Supply for submersible Pump, etc.
- Power Supply for lightings, etc.
- Power Supply for electric tools, home appliances

4 Parts (Components)

4-1. Outer and Main Components

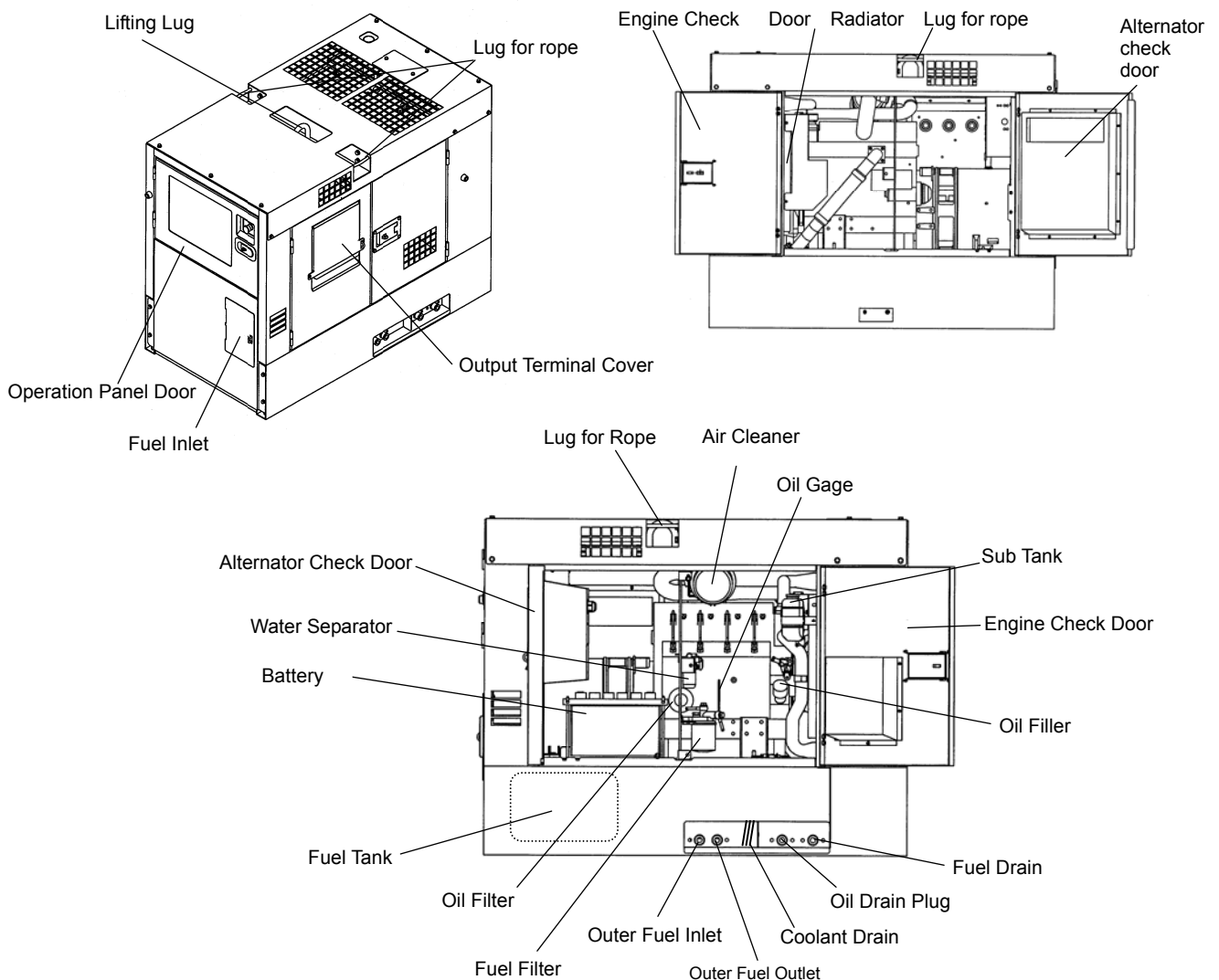

4-2. Operation Panel

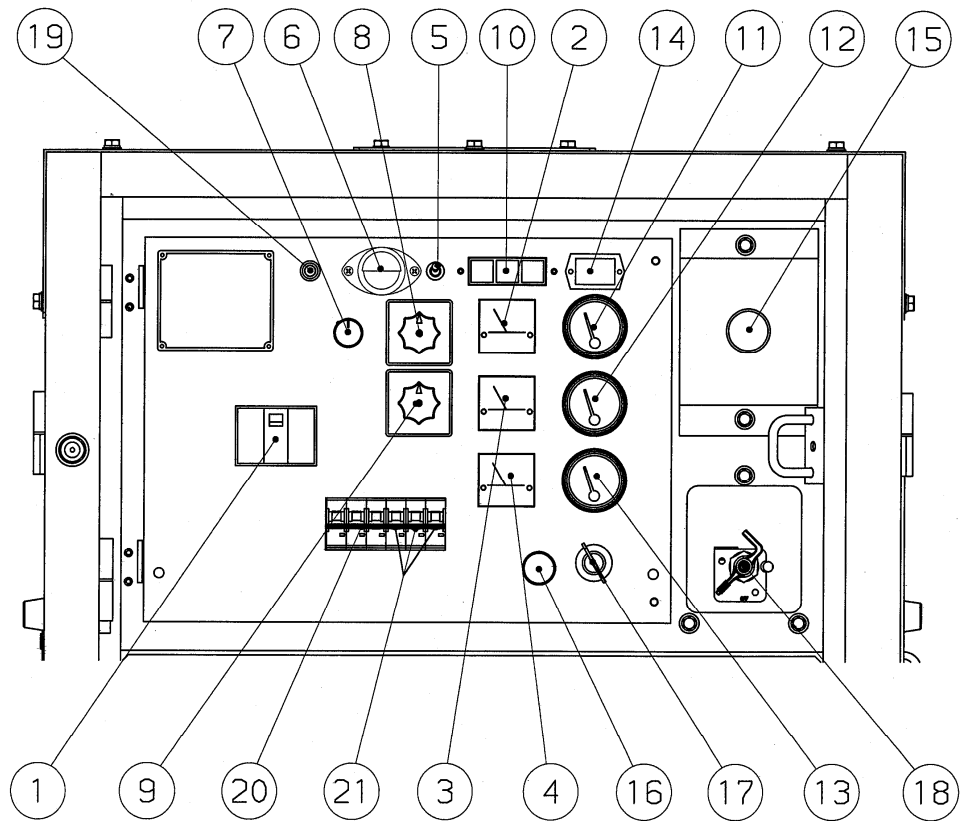

1	Main Circuit Breaker	12	Oil Pressure Gauge
2	Volt Meter	13	Fuel Gauge
3	Ampere Meter	14	Hour Meter
4	Frequency Meter	15	Emergency Stop Button
5	Panel Light Switch	16	Preheat Lamp
6	Panel Light	17	Starter Switch
7	Voltage Regulator	18	Battery Isolator
8	Volt Meter Selector Switch	19	Pilot Lamp
9	Ampere Meter Selector Switch	20	3-Phase Breaker
10	Monitor Lamp	21	1-Phase Breaker
11	Water Temperature Meter		

4-3. Output Panel (Side Door)

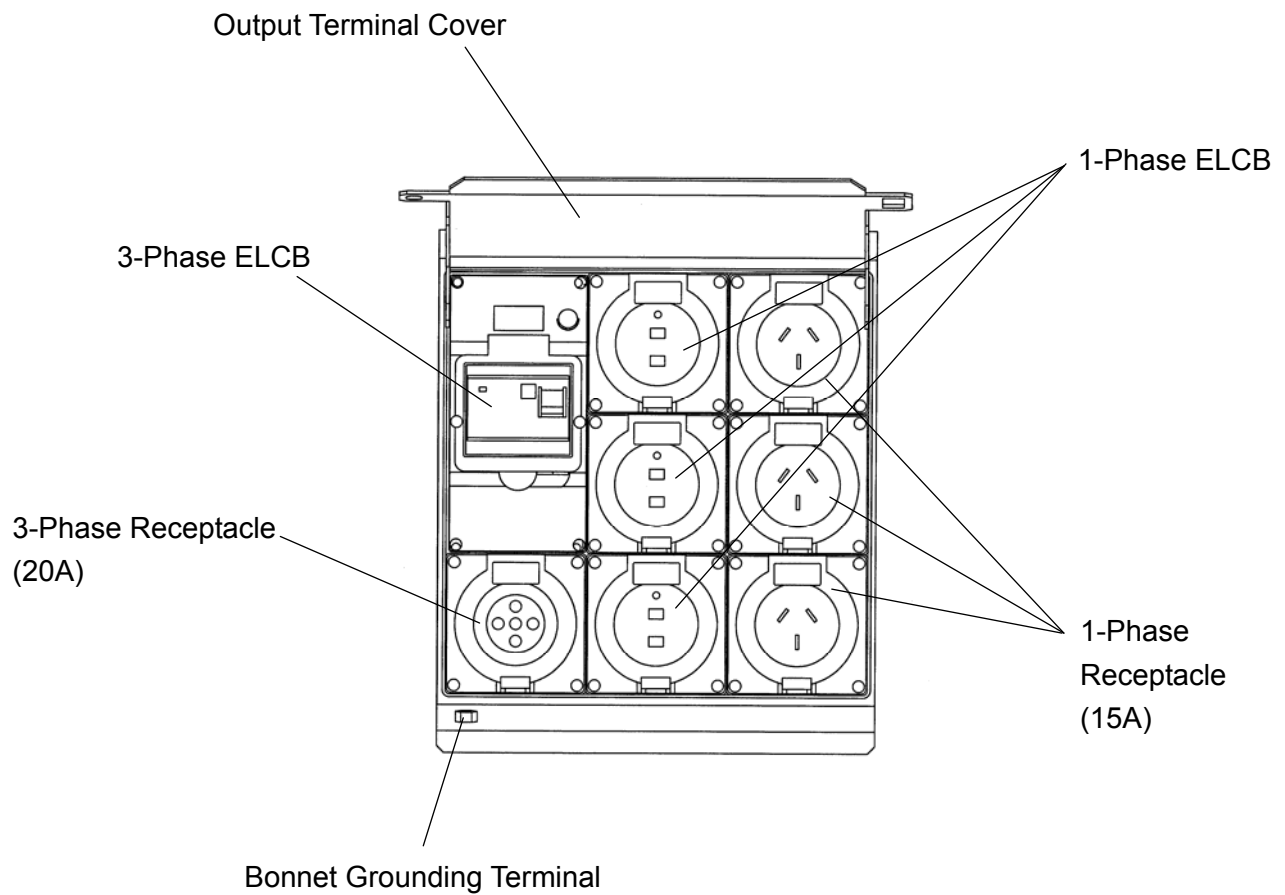

5 Equipment

5-1. Monitor Lamp

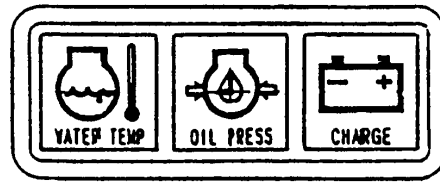

The equipment is incorporated in monitoring function of WATER TEMP, BATTERY CHARGING & OIL PRESSURE.

Under normal condition, when the starter switch changes from STOP to RUN, all the lamps of BATTERY CHARGING and OIL PRESSURE turn ON. When the engine starts, all the lamps turn OFF.

When abnormality is detected about WATER TEMP and OIL PRESSURE, the corresponding monitor lamp will flash, and the engine is automatically shutdown.

When the automatic shutdown is engaged, turn the starter switch to STOP position once, and then restart the engine. In the event the automatic shutdown happens after that, check which lamp turns ON or OFF and point out where is the abnormality.

(1) Coolant / Water Temperature Monitor Lamp



Danger : Injuries

- Close all doors and place during operating this equipment, to avoid injuries by unintentionally touching cooling fan and fan belt.



Caution : Burns

- Do not open the radiator cap while operating this equipment or immediately after stopping the equipment, to avoid sustaining burns from hot vapor.
- Do not touch the engine and muffler during operation and immediately after stopping the equipment, for the temperature can reach extremely high.

When the water temperature rises over 110°C, the coolant/water temperature monitor lamp will flash, and the automatic shutdown of engine will be engaged.

When this occurs, check the coolant / water reservoir tank, and replenish if needed.

(Refer to 『8-2 Checking coolant/water』)



WATER TEMP

If the water level is normal, there may be a possibility of loose fan belt or water leakage in coolant lines. Check it after the engine cools down.

<Caution>

- Be sure to check the volume in the radiator sub-tank before operation as it cannot detect the water temperature When the water volume is insufficient.

(2) Oil Pressure Monitor Lamp (Low Oil Pressure)



Danger : Injuries

- Close all doors and place during operating this equipment, to avoid injuries by unintentionally touching cooling fan and fan belt.



Caution: Burns

- Do not touch the engine and muffler during operation and immediately after stopping the equipment, for the temperature can reach extremely high.
- Do not open the radiator cap while operating this equipment or immediately after stopping the equipment, to avoid sustaining burns from hot vapor.
- When checking engine oil or changing oil, always stop the engine, and wait until the engine cools down. If you open either the oil gauge or the oil plug during operation, hot oil may cause some injury.



OIL PRESS

When the engine oil pressure drops below $0.98 \times 100\text{kPa}$ { 1kgf/cm^2 } during operation, the oil pressure monitor lamp will flash, and the automatic shutdown will be engaged.

When this occurs, check the engine oil level, and replenish to the maximum level if needed.

<Caution>

- The engine oil pressure monitor cannot detect the degradation of engine oil itself. Please check the engine oil periodically, and change if needed. (Refer to 『8-1. Checking engine oil』)

(3) Battery Charge Monitor Lamp (Charging Lamp)

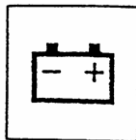

CHARGE

When the battery turns unable to be charged during operation, the battery charge monitor lamp will flash. In the event this occurs, stop the engine consult with the authorized distributor or our engineering section.

<Caution>

- The battery charge monitor cannot detect the degradation of the battery nor the battery fluid level. Check the battery fluid level periodically. (Refer to 『8-6. Checking Battery』)

5-2. Meters

Meters in the engine

(1) Hour Meter

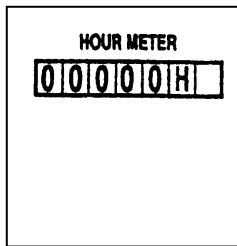

Hour Meter keeps track of utilization time. Use this meter to schedule your Periodical Maintenance. Note that the Hour Meter will operate, as long as the start switch is at ON position, regardless of whether the engine is running or stopped.

(2) Water Temperature Gauge

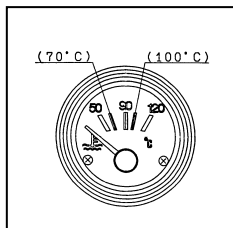

Water Temperature Gauge displays the temperature of engine coolant. Normal temperature may vary depending on the environment, but it should be between 80°C and 95°C.

<Caution>

If the temperature exceeds normal value, disconnect the load, idle the engine at 1000min⁻¹, and wait until the reading falls to the normal temperature range.

(3) Oil Pressure Gauge

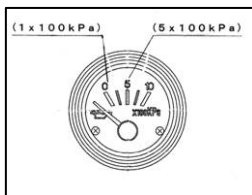

Oil Pressure Gauge displays the pressure of engine oil. Normal pressure may vary depending on the environment, but it should display 2.9-4.9 x 100kPa (3-5kgf/cm²). However, under cold weather, the pressure gauge may display higher reading. Continue idling until the pressure falls to normal range.

(4) Fuel Gauge

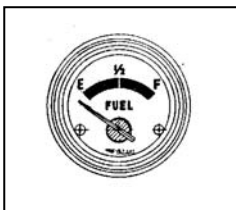

It shows the volume in the fuel tank.

When filled up, it shows 『F』.

When the hand is approaching to 『E』, the volume is coming to empty. Replenish fuel enough promptly.

Generator Gauges

(1) Volt Meter

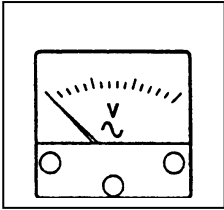

Voltage Meter displays the output voltage (Phase to Phase) from the generator.
Please check and confirm it showing 415V at 50Hz during operation.

(2) Ampere Meter

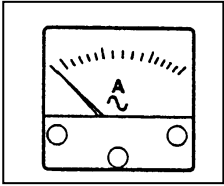

Ampere Meter displays the output current (Phase) from the generator.

(3) Frequency Meter

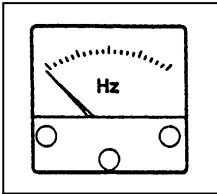

Frequency meter will display the frequency of the generator.
Please check it showing 50Hz during operation.

Lamps

(1) Preheat Lamp

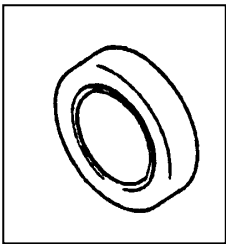

When the starter switch is turned to <Run/Preheat> position, the preheat lamp will be turned ON. The preheat lamp will be turned OFF after preheating completes showing the engine start possible.

<Caution>

- Preheating time varies to coolant temperature, usually about 1-5 seconds.

(2) Pilot Lamp

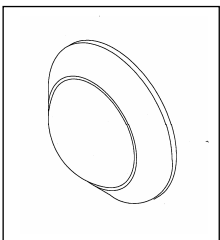

The lamp indicates whether or not the equipment is generating electricity when the engine is running.

(3) Panel Light

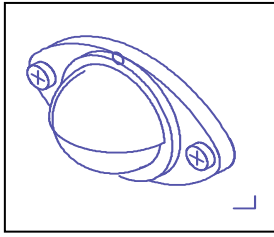

Panel light turns ON to illuminate the panel, when turning the switch (by the light) to ON.

Switches

(1) Starter Switch

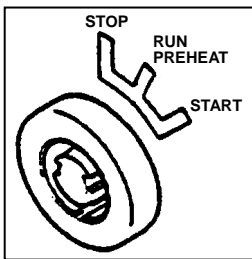

1. Stop

When the switch is set to this position, all power will be off. The switch must be set to this position to remove the key.

2. Run / Preheat

The switch must be set to this position during operation. This position is also used during cold season, to preheat Glow Plug.

<Caution>

- Do not leave the switch to this position, while the engine is stopped. Otherwise the battery is discharged.

3. Start

This position is to start the engine. When the key is released, the setting will automatically return to <Operating / Preheating> position.

(2) Emergency Stop Button

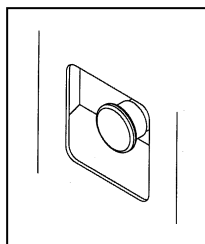

This button is used to stop the engine in emergency. By inserting the button, the engine stops. Be sure to restore the starter switch to STOP and re-set the button, turning clockwise after using the emergency stop button.

(3) Main Circuit Breaker

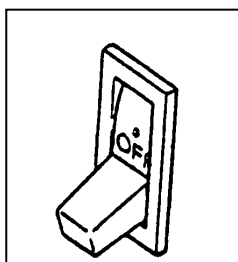

By turning this circuit breaker on the control panel to ON, Power will be transferred to the output receptacles and to the load side. The breaker trips to OFF, either overload or short-circuit.

<Caution>

- Do not use this breaker as the ON/OFF switch to the load.

(4) 3-Phase Circuit Breaker

1-Phase Circuit Breaker

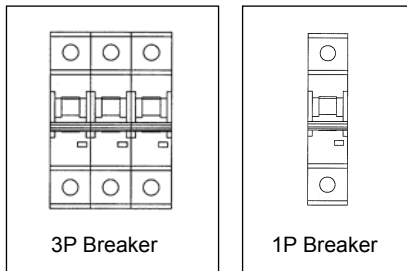

Each receptacle, 3-Phase and 1-Phase is incorporated with circuit breaker respectively. The breaker trips on overload or short-circuit on to stop power transmission to load.

<Caution>

Do not use this breaker as the ON/OFF switch to the load.

(5) 3-Phase Earth Leakage Circuit Breaker (3P ELCB)

1-Phase Earth Leakage Circuit Breaker (1P ELCB)

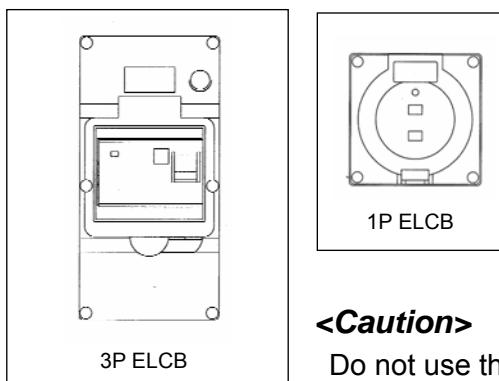

Each receptacle, 3-Phase and 1-Phase is incorporated with ELCB respectively. When current leak occurs, it trips to stop power transmission to load.

<Caution>

Do not use this breaker as the ON/OFF switch to the load.

(6) Volt Meter Selector Switch

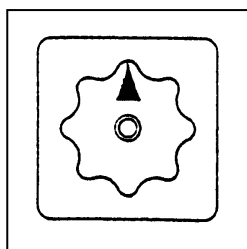

By changing the switch, the voltmeter displays the voltage between the lines.

(7) Ampere Meter Selector Switch

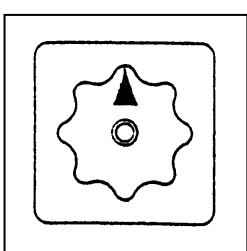

The phase current displays in the meter, by switching to each phase (R, S and T) position.

(8) Battery Isolator

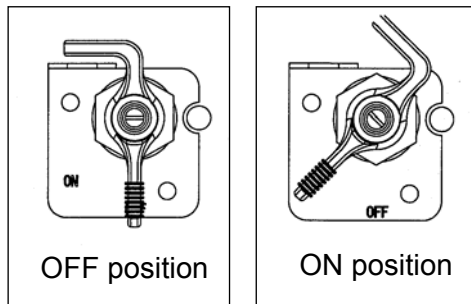

When turning the switch to OFF, the engine electric circuit does not activate due to no battery power.

Voltage Regulator

(1) Voltage Regulator

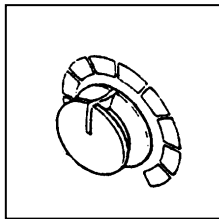

The dial adjusts generator output voltage.

By turning the dial clockwise, you can increase the voltage.

By turning the dial counter-clockwise, you can decrease the voltage.

5-3. Fuel Line Changeover Valve (3-way valve)



Caution : Fire

- Always stop the engine when performing any work on the fuel line.
- Always wipe any drip of Diesel fuel or engine oil. Do not use this equipment, when a leak is found. Repair the equipment before use.
- Be sure to confirm that there is no leakage in the piping.

By switching the 3-way valve, you can use fuel from external fuel tank.
In this case, the built-in tank fuel cannot be used.

(1) Using fuel from built-in fuel tank

The lever for 3-way valve is set to **A** when the equipment is shipped.
Outer fuel inlet and return are closed with plugs (PT1/2).
Use fuel as they are.

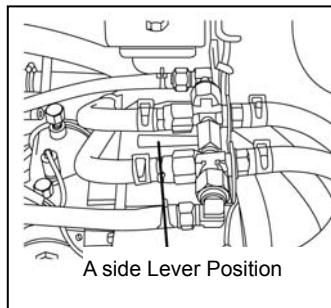

A side Lever Position

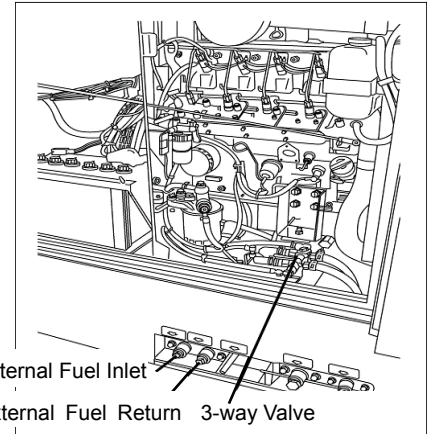

External Fuel Inlet
External Fuel Return 3-way Valve

<Caution>

- After having used the outer fuel and removed piping, be sure to set the lever to A position and fix the plugs.

(2) Using fuel from external fuel tank

Connect hoses from the external fuel tank to the external fuel intake and the external fuel return ports, and set the lever for 3-way valve to **B** position.

You can now supply the fuel
From the external gas tank.
For detailed instructions, refer to
『9-5.Connecting to External
Fuel Tank』

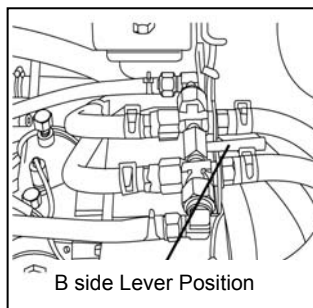

B side Lever Position

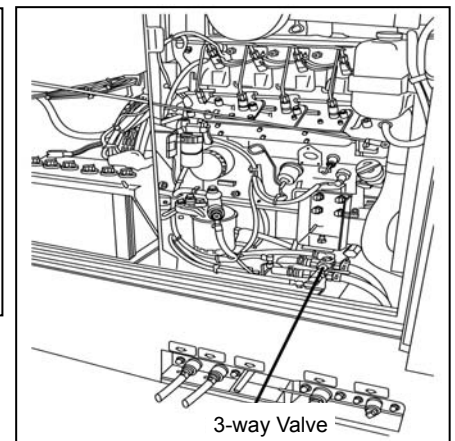

3-way Valve

6 Transportation and installation

6-1. How to transport

Danger : Injuries

- When lifting the equipment, always use a lift hook.
- Never use roping lug for lifting the unit, for it may cause equipment to drop.

(1) Lifting the equipment

Always use a Lift lug, when lifting the equipment for transportation.

(2) Transporting the equipment

When transporting the equipment, make sure that the equipment is secured properly with ropes tied to the roping lugs through.

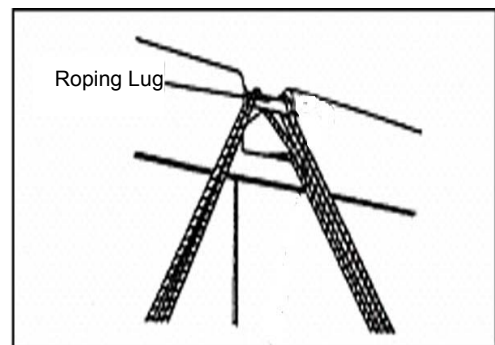
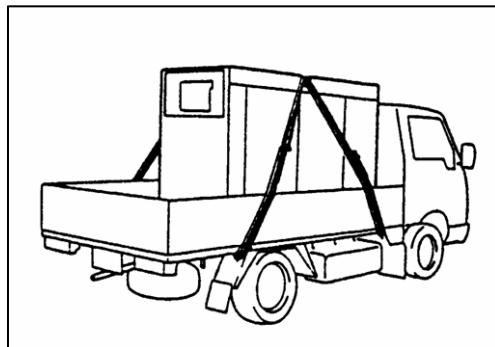
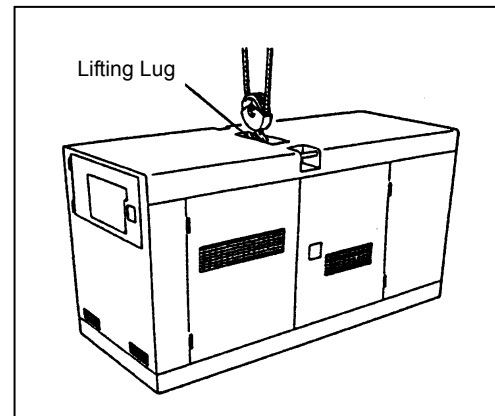

<Caution>

- Always use extreme care when loading, unloading, and transporting the equipment, otherwise damages and malfunction of the equipment may bring.

6-2. Installation



Danger : Suffocation from exhaust gas

- Exhaust fumes from the engine contains many elements harmful to humans. Do not operate this equipment in poorly ventilated area, such as inside a room or in a tunnel



Caution : Suffocation from exhaust gas

- Do not point the exhaust fume toward pedestrians or buildings.



Caution : Fire

- Always operate this equipment on flat surface and, at least 1 meter away from any objects (wall, box, etc.).
- Temperature around muffler and exhaust can get extremely high. Keep any inflammable items (such as fuel, gas, paint, etc.) away from the equipment.

- Always set the equipment on hard, flat surface.
- Keep the equipment at least 1m from a wall or any obstacles, to allow workable space to access the control panel and opening of the panel door.

<Caution>

- This equipment must be operated on hard and flat surface. Operating under any other conditions may result in malfunctions.
- Do not block the airflow from radiator vent or muffler exhaust. It may result in reduced engine performance, overheating, or damage to the electrical parts.
- Operating in dusty area or salty air (by the ocean), or any other particulate environment may result in clogged radiator, which may cause overheating, other malfunctions and insulation deterioration. Use extreme care, frequent checks and maintenance.

7 Connecting Load

7-1. Select Load Cable

Select the cable with proper gauge, based on its allowable amperage and the distance between the generator and the machinery to be connected.



Caution : Damage to properties

- If the load exceeds the allowable amperage, the damage to the cable may be damaged in overheating.
- If the cable is either too long or too small gauge, there will be greater voltage drop between cables which brings voltage drop to loads. It may result in reduced performance in the connected loads, malfunction, or damages.

<Caution>

- It is recommended to select the proper gauge and length of cable, in consideration of the maximum 5% marginal drop only for the rated voltage, between the terminals of loads and generator via the cables.

■ Expedient Formula: the voltage drop of cables

● 3-Phase 3-Wire

$$\text{Voltage Drop (V)} = \frac{1}{58} \times \frac{\text{Length (m)}}{\text{Dia (mm}^2\text{)}} \times \text{Current (A)} \times \sqrt{3}$$

● 1-Phase 2-Wire

$$\text{Voltage Drop (V)} = \frac{1}{58} \times \frac{\text{Length (m)}}{\text{Dia (mm}^2\text{)}} \times \text{Current (A)} \times 2$$

7-2. Connecting Load Cable



Danger : Electric Shock

- Before connecting or disconnecting a load cable from output receptacles, always turn a circuit breaker to OFF position, stop the engine, and remove the engine key. The person performing the maintenance should always keep the key.



Caution : Fire

- Do not connect AC output to any indoor wiring.

<Caution>

- Divide loads into 3 circuits proportionally as possible, when using the maximum output power especially, and connect them to each phase (R,S,T) respectively.
- Be careful to limit the current under the rated current per the phase.
- Note that the 1-phase output power decreases when 3-phase output power is used simultaneously.
- Be careful to limit the total current under the rated output current when using 1-Phase and 3-Phase output simultaneously.

7-3. Earth Leakage Circuit Breaker (ELCB) and Grounding

Danger : Electric Shock

- Ground the every grounding terminal to the earth as set in the manual. If even one of all is unconnected by mistake or accident, it will be much more dangerous for human than the NO-RELAY case, because leaking current inevitably goes through the body.
- Even though all the bonnets of the loads have been grounded to the earth, the earth grounding terminal and the outer bonnet (canopy) grounding terminal should be grounded to the earth.
- Grounding should be made after the engine is stopped.
- Whenever the Earth leakage breaker is activated, you should always repair the leaking place first of all.

The generator is provided with the earth leakage circuit breaker(ELCB) to detect any Leakage produced due to such the trouble as insulation failure of the load while the generator is running and to cut off the circuit for protection against any accident such as electrical shock resulting from the trouble.

The specification of ELCB;

- Rated Sensitive Current: 30mA (or below) (Grounding resistance: 500 Ω or below)
- Sensitive time: Within 0.1second

(1) Grounding Work

The qualified electrician should perform the grounding of the following 2 points (500 Ω or below).

- The Bonnet (Canopy) grounding terminal of the generator
- The Bonnet of the load

<Caution>

- In the event you cannot ground the generator to the earth, consult with the authorized distributor or our engineering section

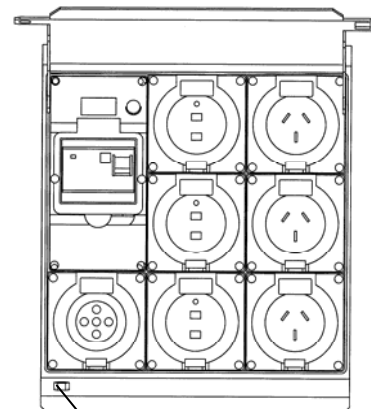

Bonnet grounding terminal

(2) Operation Check

Danger : Electric Shock / Injuries

- Before turning Breaker or ELCB to ON position, ensure that the breakers or the switches of loads are positioned to OFF. You should communicate well with the electrician by the load side when operating Breaker or ELCB.

Before operating the generator, check always if the device can work.

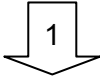
 1 Ensure that the breakers and the switches of loads are positioned to OFF.

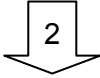
 2 Ensure every breaker to set OFF. Refer to 『4-2.Operation Panel』 and 『4-3.Output Panel』

 3 Following the procedure in 9-1, Initializing / Preparation, start an engine.

 4 Turn every breaker and ELCB to ON. Push the RESET (Green) button on the 1-Phase ELCB. Confirm the red lamp on the 1-Phase ELCB turned ON and the indicator on the 3-Phase ELCB turns RED display.

 5 Push the TEST button (Yellow) on 3-Phase ELCB. Indicator changes to Green from RED and ELCB trips to OFF, Which shows NORMAL.

 6 Push the TEST button (Blue) on 1-Phase ELCB. Red lamp turns to OFF and ELCB trips to OFF, Which shows NORMAL.

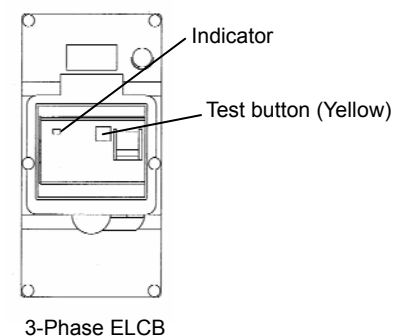
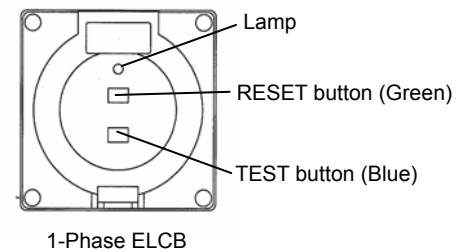
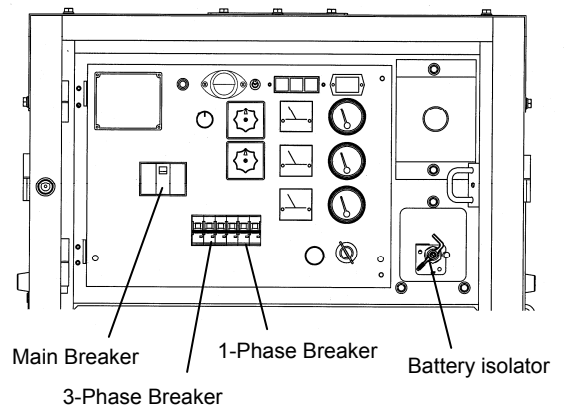

In the event you cannot complete every step of the above procedure to the end, the device is out of order. Consult with our authorized distributor or our engineering section and ask to repair.

(3) Earth leakage circuit breaker (ELCB) has activated

When the ELCB has activated, repair the leakage point and restore it by the following procedure.

(Overload happens when the breaker activates but the Earth leakage breaker does not activate.)

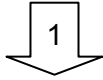

Turn the 3-Phase ELCB to ON to restore.
Turn the 1-Phase ELCB to RESET to restore.

By the above procedure, you can reset the ELCB to ON positions.

8 Initialization and Pre-check



Danger : Electric Shock / Injuries

- Before performing any equipment check or maintenance, stop the engine, and remove the engine key. The person performing the maintenance should always keep the key.



Caution : Fire / Burns

- When checking engine, always stop the engine, and keep away from fire. Wait until the engine cools down, before performing any checks.



Caution : Fire

- Always wipe any drip of fuel or oil. Do not use this equipment when a leak is found. Repair the equipment before use.

8-1. Checking engine oil

※Please refer to the user's manual for Engine separately

When checking for engine oil, be sure to keep The equipment leveled, and insert (not screw in forcibly) the oil gauge all the way in.

Prior to starting the equipment, make sure to fill the engine oil to the MAX line through the oil filler.

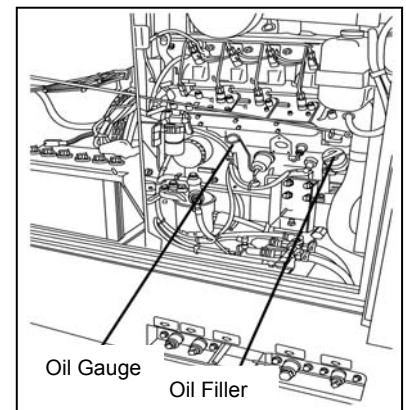

<Caution>

- Check engine oil volume IN 10-20 MINUTES LATER, always after stopping engine or replenishing fuel.
- If the equipment is not leveled, you cannot obtain accurate oil level.
- Do not overfill the engine oil. The excessive amount of engine oil may damage the engine.

(1) Selecting proper engine oil

Use the API class CD grade or higher.

(2) Use the engine oil for Diesel engine with proper viscosity, based on the temperature (refer to the chart below).

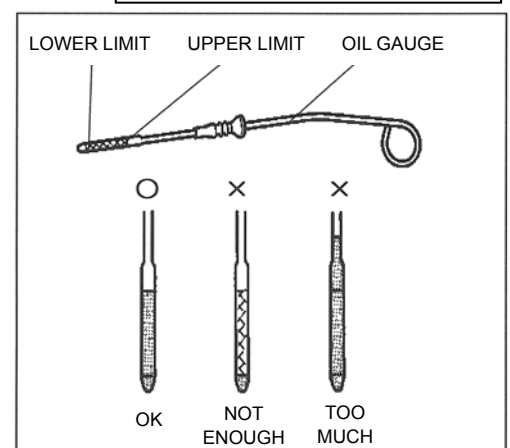

- Viscosity and temperature

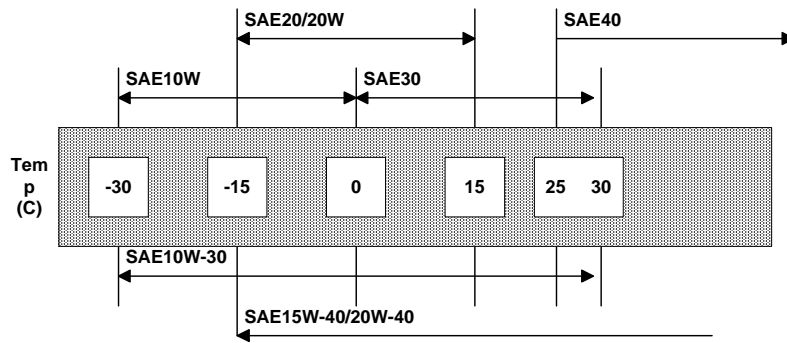

(3) Replacing Engine Oil Volume

(Unit: Liter)

Lubrication Oil (including the oil in filter)
8.5 (0.4)

Value in () shows the oil in filter

8-2. Checking Coolant / water

※ Refer to the User's Manual for Engine also.



Danger : Injuries

- Before performing any equipment check or maintenance, stop the engine, and remove the engine key.
The person performing the maintenance should always keep the key.



Caution : Burns

- Do not open the radiator cap while operating this equipment or immediately after stopping the equipment, to avoid sustaining burns from hot vapor or water.
- Do not touch the engine and muffler during operation and immediately after stopping the equipment, for the temperature can reach extremely high levels.

Check the radiator and coolant reservoir tank for water and add water in case of shortage.

(1) Checking Radiator / Adding water

- 1 Remove the radiator plate and open the radiator cap cover.
- 2 Remove the radiator cap.
- 3 Fill up water to the radiator water inlet top.
- 4 Reinstall the cap and tighten it.
- 5 Close the radiator cap cover and reinstall the radiator plate.

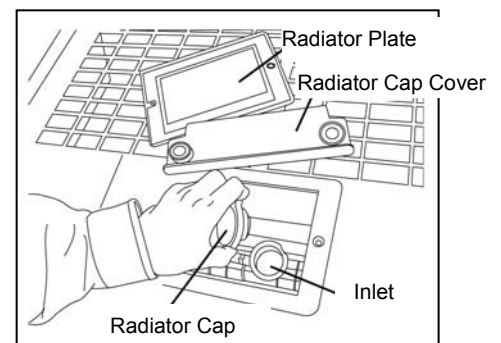

(2) Checking Coolant in sub tank / Adding coolant

- 1 Check to see if the water/coolant level is between MAX and MIN line in the sub tank.
- 2 Fill up to the MAX line, if the water/coolant level is low.

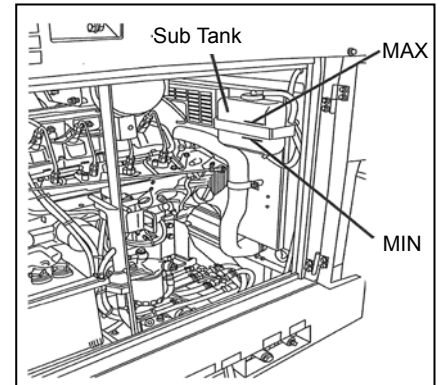

<Caution>

- Be sure to use the long life coolant (LLC) for the aluminium radiator only. The coolant should be mixed good quality softened tap water with anti-freezing and anti-rust liquid.
- At ex-factory, the LLC mix ratio is 30% liquid and 70% water is installed. (Isuzu Genuine LLC: Besco LLC Super-Type E)
- Be sure to use the same LLC into sub tank.
- The mix ration should be changed to ambient temperature but between 30 and 50%.
- When replenishing LLC, be sure to use the same brand as the LLC left in the radiator and sub tank.
- Never use the mixed LLC by different brands.
- Be sure to change wholly in less than 2 years or 1000 hours.

Mixture ratio (for reference only) :

Ambient temperature	-15°C	-23°C	-35°C
Mixture ratio	30%	40%	50%

(3) Coolant Volume

Unit: L

Total Coolant Volume (including sub tank)
8.2 (0.9)

The value of () shows the sub tank volume.

8-3. Checking Fan Belt

※ Refer to the user's manual for Engine separately also.



Danger : Injuries

- Before performing any equipment check or maintenance, stop the engine, and remove the engine key. The person performing the maintenance should always keep the key.
- Close and lock all doors during operating this equipment, to avoid injuries by unintentionally touching cooling fan and fan belt.



Caution : Burns

- Do not touch the engine and muffler during operation and immediately after stopping the equipment, for the temperature can reach extremely high level.

(1) Fan Belt Tension

The tension is proper when the fan belt has 8 to 10mm slacks, when applying a finger pressure (about 98N {approximately 10kgf}) at midpoint between fan pulley and alternator pulley.

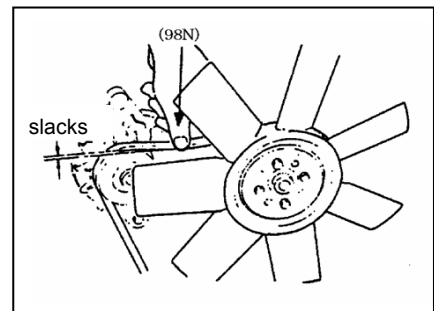

(2) Condition

Check for any damage on the fan belt.
Replace if necessary.

<Caution>

Refer to the <User's manual for Engine> for adjusting and replacing of the fan belt.

8-4. Checking fuel



Caution : Fire

- Always wipe any drip of Diesel fuel or oil.
- Do not use this equipment when a leak is found.
Repair the equipment before use.

Check for the fuel level in the tank. Add if necessary.

<Caution>

- Use Diesel fuel, ASTM D975 No.2-D in the event ambient temperature reaches down to -5°C .
- Always use the Diesel fuel strainer
- Fill the fuel tank slightly less than the FULL tank level.
- The engine is designed to use either No.1-D or No.2-D Diesel fuel. However, for economical purpose, use No.2-D Diesel fuel whenever possible at the temperature less than -7°C , No.2-D fuel may pose operating problems. At the much colder temperature, use No.1-D fuel (if available) or use winterized No.2-D (blend of 1-D and 2-D).

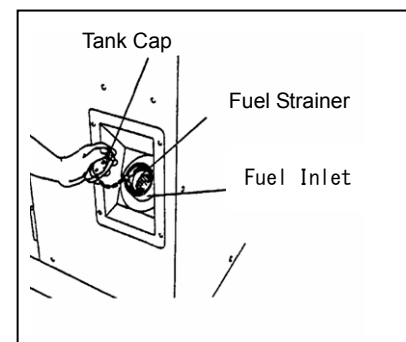

This blended fuel is usually called also No.2-D. It can be used in colder temperature than N0.2-D fuel, which has not been winterized. Check with service station operator to be sure you can get the proper blend fuel.

- Fuel requirements:

NOTICE: *The fuel injection pump, injector or other parts of the fuel system and engine can be damaged if you use any fuel or fuel additive other than those specifically recommended by Isuzu.*

Such damage is not our responsibility, and is not covered by the Warranty.

To help avoid fuel system or engine damage, please heed the following:

- *Some service stations mix used engine oil with diesel fuel. Some manufacturers of large diesel engines allow this; however, for your diesel engine, do not use the diesel fuel which has been contaminated with engine oil. Besides causing engine damage, such fuel can also affect emission control. Before using any diesel fuel, check with the service station operator to see if the fuel has been mixed with engine oil.*
- *Do not use any fuel additive. At the time this manual was printed, no other fuel additive was recommended. (See your authorized dealer to find out if this has changed.)*

8-5. Checking Fuel, Engine Oil, and Coolant leakage



Caution : Fire

- Never use this equipment when a leak is found. Repair the equipment first of all.

Be sure to check for any fuel leak at the fuel hose connections, and oil and coolant leak by opening side doors.

8-6. Checking Battery



Caution : Injuries to eyes and skin

- Battery fluid contains diluted sulfuric acid. Avoid contact with eyes, skin or on clothing. If the acid comes in contact, especially with eyes, flush with a lot of water, and contact physician or doctor immediately.



Caution: Explosion

- When the liquid level is below the LOWER level, never use the equipment nor recharge battery.
- Battery may emit some combustible gas, so keep it away from fire and sparks.

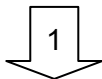

Check the fluid level. If the level is near or lower than the LOWER LEVEL, add distilled water until the fluid level reaches the UPPER LEVEL limit.



Make sure that the battery cables are firmly secured to the posts. Tighten the clamps more if necessary.

<Caution>

- Check the hydrometer of the battery fluid. If it falls below 1.23, the battery requires recharging. Please call our authorized distributor or our engineering section.

■ Replacing the battery

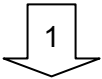

Remove the clamp and cable from negative (-) post from the battery (always remove negative side first).



Remove the battery fixing clamp



Remove the cable from positive (+).



Remove the battery from the seat

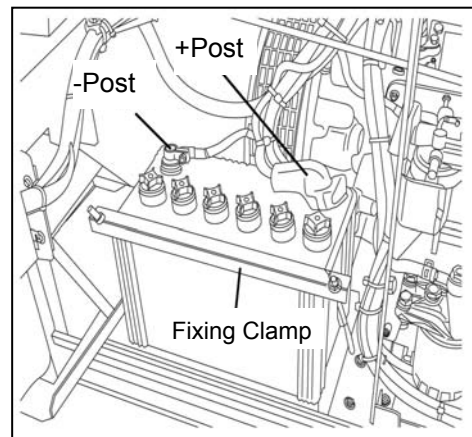

※Reinstall a new battery in the reverse order (always install the cable to the **positive (+)** post of the new battery first).

9 Operation

9-1. Initialization and Preparation



Danger : Suffocation from exhaust gas

- Exhaust fumes from the engine contains many elements harmful To humans. Do not operate this equipment in poorly ventilated area, such as inside a room or in a tunnel



Caution : Suffocation from exhaust gas

- Do not point the exhaust fume toward pedestrians or buildings.



Caution : Fire

- Temperature around muffler and exhaust can get extremely high levels. Keep any inflammable items (such as fuel, gas, paint, etc.) away from the equipment.
- Always operate this equipment on flat surface and, at least 1 meter away from any objects (wall, box, etc.).



Caution : Injuries

- Always place the equipment on a flat and stable surface, to keep the equipment from sliding.
- When starting the engine, turn off the connected equipment and set the circuit breaker to OFF position.

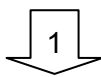

Turn every circuit breakers to OFF position.

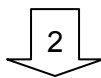

Turn the Battery Isolator to ON position.

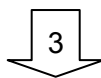

Set the Starter Switch to OPERATION / PREHEAT position.



Set the starter switch to START and start the engine immediately after the Preheat Lamp turns OFF from ON.

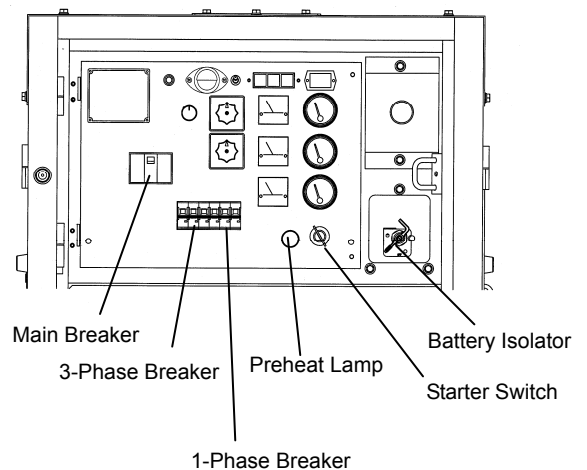

<Caution>

- Preheating time varies by coolant temperature. It completes in 1-5 seconds usually.
- Do not drive the starter motor more than 10 seconds successively.
- If you need to restart, wait at least 30 seconds before the retry.



Release the starter switch, as soon as the engine is started

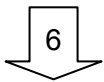

Keep the engine idle for about 5 minutes.



Set the throttle lever to RUN.
Ensure that the tachometer shows the following frequency at no load.

	No Load Frequency (Revolving Speed)
50Hz RUN	52.5Hz (about) (1575min ⁻¹)

<Caution>

- In either case of incorrect frequency, adjust the frequency by FREQUENCY ADJUSTING SCREW.
- By setting frequency to the above frequency under no load, 50Hz(almost) will be obtained at the rated output load.

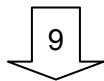

Adjusting the voltage regulate dial, set it to the required voltage.

50Hz RUN	415V
----------	------

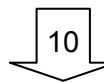

Turn the circuit breakers to ON to send power to the load side.



Danger : Electric Shock / Injuries

- Before turning the circuit breakers to ON to send power to the load side, always ensure that any circuit breaker and switch of loads are positioned to OFF.
In the case the generator and the load are away from each other, proceed with the above steps, communicating well with the other person by the load in order to prevent from accident.

9-2. During Operation

(1) Post startup check

- Make sure that all meters (gauges) and displays are working properly.
(Refer to 5. Equipment)
- Check for any unusual vibration or noise.
- Check for any unusual color from the exhaust. Under normal condition, the exhaust gas has no color or light bluish color.
<Caution>
- If finding out abnormality, consult with our authorized distributor or our engineering section in order to repair, without using the machine.

(2) Adjustment during operation

- Make subtle adjustment to voltage using the Voltage Regulate Dial, by monitoring Voltage Meter during operation.

■ Extracting the air out of the fuelling system for engine stop due to no fuel

※Refer to the User's manual for Engine.

This generator is equipped with automatic extracting feature. Thus if the engine stops due to running out of fuel, follow the next steps to extract the air out.

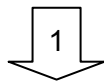

Add fuel to the fuel tank.

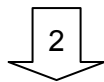

Turn the starter switch to RUN position. It will take approximately 30 seconds to extract the air out.

9-3. Stopping

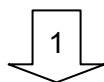

Turn the switch on the equipment and the circuit breaker on the load to OFF.

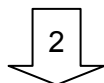

Turn every circuit breaker to OFF position.

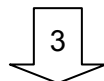

Keep the engine NORMAL SPEED on No Load for about 3 minutes.



Turn the starter switch to STOP.

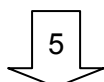

Turn the battery isolator to OFF.

9-4. Protection Feature

This equipment is equipped with automatic shutdown feature and display of the location of trouble, against trouble during operation. In the event of the automatic shutdown or alarm lamp flashing, turn off the engine and investigate the trouble shown by alarm lamp.

Protection Feature List

No.	Action		ELCB Trip	Breaker Trip	Engine Automatic Shutdown	Warning Lamp Flash	Cause
	Abnormality						
1	Monitor Lamp	High Water Temperature	—	—	○	○	Activates due to high water temperature in engine Default 110°C
2		Low Oil Pressure	—	—	○	○	Activate due to low oil pressure in the engine Default 0.98×100kPa {1.0kgf/cm ² }
3		Battery Charge Insufficient	—	—	—	○	Activates in battery charge Impossible
4	Current Leakage		○	—	—	—	Activates in current leakage
5	Overload		—	○	—	—	Activates in overload

※ ○ indicates the automatic activation

9-5. Connecting to External Fuel Tank



Caution

- Always stop the engine, when working on the fuel line.
- Always wipe any drip of Diesel fuel or oil. Do not use this equipment when a leak is found. Repair the equipment before use.
- Ensure that there is no fuel leakage on the fuel line after the fuel line working finished.

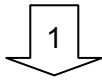

Turn the 3-way valve lever to A position.
(Installed tank use position)

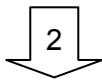

Disconnect the P/T 1/2 plugs from the external fuel intake and the external fuel return, and then connect the hoses from the external fuel tank, as shown below.

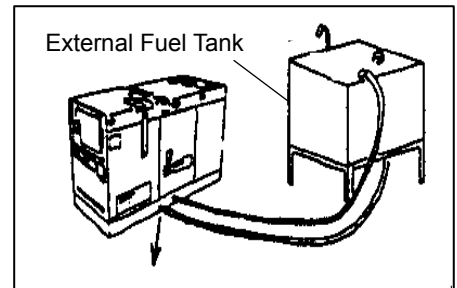

Turn the 3-way valve lever to B position.
(External tank use position)



Extract the air out from the connected hoses.
By the above procedure, it makes possible to use an external fuel tank.

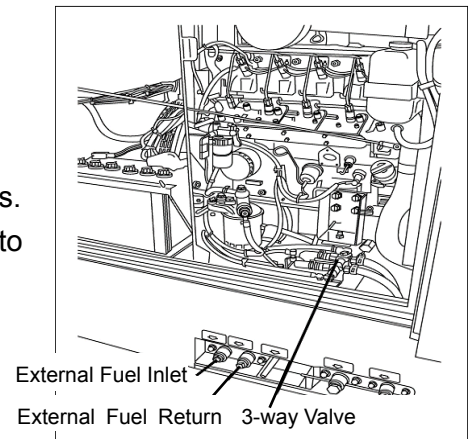

<Caution>

- Use always oil-proof hose in 8-10mm inner diameter as connecting hose.
- The fuel level in the external fuel tank should be 0 to 3m higher than the bottom of the equipment. Otherwise, it may cause engine malfunction or stoppage.
- To avoid any leak from the external fuel intake and return ports, always turn the lever for 3-way valve to A position whenever piping work is performed.
- Use extreme caution when connecting the hoses. If the lever position is set improper, the fuel may leak from either the built-in fuel tank or the external fuel tank.
- Set the fuel intake position 15-20mm above from the external fuel intake bottom line, otherwise water or garbage in the tank may come into the fuel line.
- In order to avoid engine malfunction due to air suction, set the fuel return at the same level as the fuel intake level in the external tank.

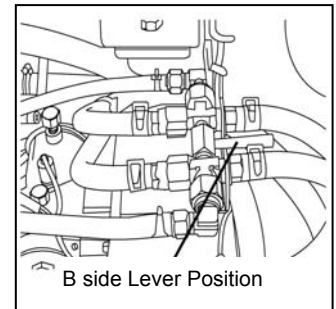
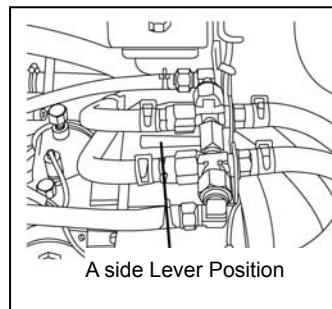

- Refer air extraction to 『9-2. During Operation』
- Just after having connected to external fuel tank, there may be a case that engine speed is unstable and engine stops due to insufficient air extraction. Therefore, be sure to confirm that the air is extracted completely and the engine speeds keeps stable before leaving the equipment under people-less operation.

10 Check/Maintenance



Danger : Electric Shock/Injuries

- Before performing any equipment check or maintenance, stop the engine, and remove the engine key. The person performing the maintenance should always keep the key.



Caution : Fire/Burns

- When checking engine, always stop the engine, and keep away from fire. Wait until the engine cools down, before performing any checks.



Caution : Fire

- Always wipe any drip of fuel or oil. Do not use this equipment when a
- Leak is found. Repair the equipment before use.

To optimize the use of this generator, we recommend the periodical equipment checks and maintenance, based on following maintenance matrix. Use the hour meter as a guide for the operating time.

<Caution>

- The authorized technicians only should perform all maintenance work, except for the pre-startup checks.
- Request for the maintenance items with ● mark to our authorized dealer or our engineering section.
- This chart only covers the simple checks and maintenance as for the engine. For more detailed guide, please refer to the User's Manual for the engine.
- Always use our genuine parts only for replacement.

Description	Startup check	Every 200hrs	Every 400hrs	Every 500hrs	Every 1000hrs
Engine Side					
Clean each parts / tightening	○				
Engine oil checks / add oil	○				
Engine oil change (<i>1st time at 50 hr mark</i>)	○	○			
Oil Filter change (<i>1st time at 50 hr mark</i>)	○		○		
Coolant level check / add coolant	○				
Exhaust color check	○				
Coolant change					○ or 2 yr.
Drain excess water and sediments in the water separator	○				
Drain water from fuel filter or replace		○ Clean		○ Replace	
Drain water from fuel tank		○			
Clean water separator and clean gauze filter in engine feed pump				○ Clean	
Change filter in the magnet pump for air extraction in fuel line					○ Replace
Clean inside fuel tank					●
Leak check (fuel, oil, and coolant)	○				
Replacing fuel hose					● or 1 yr.
Clean or replace air cleaner element		○ Clean		○ Replace	
Battery fluid level check	○				
Battery hydrometer check				○	
Fan belt check	○				
Radiator Flush Cleaning				●	
Check and adjust engine valve clearance					●
Compression check					●
Fuel injection nozzle check			●		
Fuel injection timing check					●
Generator side					
Various meter and alarm lamps check	○				
Operation check of ELCB	○				
Grounding resistance check	○				
Insulation test		○			

(1) Change engine oil

Initial	50 hours
2 nd and after	Every 200 hours

- 1 Remove the Oil Filter cap.
- 2 Remove the Oil Drain Plug and then turn the Oil Drain Lever to OPEN and drain the engine oil.

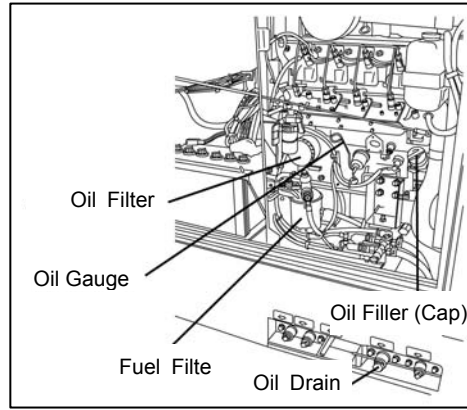

- 3 Turn the Oil Drain Lever to CLOSE and tighten the Oil Drain Plug.
- 4 Pour the oil to the upper level, checking the height with the Oil Gauge.
- 5 Tighten the Oil Filler Cap.

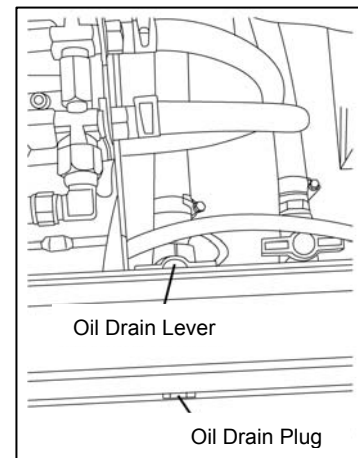

<Caution>

- For the volume and the type of engine oil to use and to replace, refer to 『8-1. Checking Engine Oil』 .

(2) Oil Filter Change

Initial	50 hours
2 nd and after	Every 400 hours

- 1 Drain the engine oil fully, as described in (1) Change Engine Oil.
- 2 Loosen and remove the Oil Filter, using an oil filter wrench.
- 3 Smear a little engine oil on the rubber gasket of the new oil filter.
- 4 Screw a new filter into place and tighten it by hand until the gasket contacts the seat. Then, give it additional 3/4-1 turns, using an oil filter wrench after the gasket touch the seal surface.
- 5 Supply engine oil.

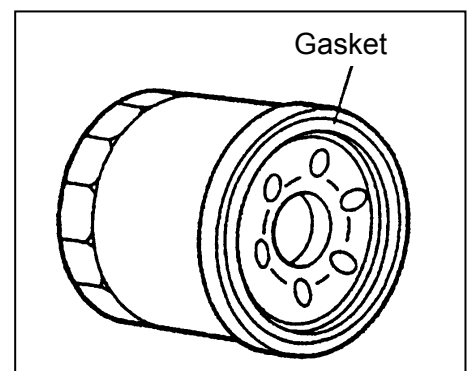

<Caution>

- If an oil filter wrench is not at hand, contact our authorized distributor or our engineering section to replace.

- Oil Filter Part No.

Isuzu Part No.	8944567411
----------------	------------

(3) Cleaning / Changing Air Filter Element

Clean	Every 200 hours
Change	Every 500 hours

1 Loosen the air cleaner fixing bolt and remove the cleaner cap.

2 Loosen the wing nut and remove the air filter element.

3 Clean or change an air filter element and reinstall it in the reverse order.

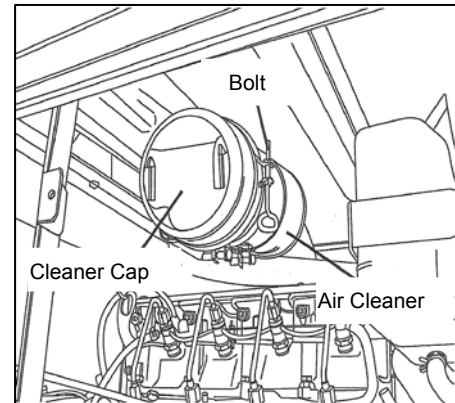

<Caution>

- Be sure to set the cleaner cap at the arrow mark upside.
- Clean the element more often where the equipment is used in dusty condition.

- Element Part No.

Isuzu Part No.	5142150140
----------------	------------

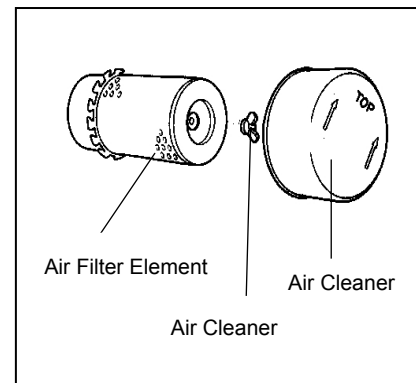

- Clean Air Filter Element
<Dried contaminants adhered>
Blast the compressed air to element from inside.
- <Carbon and oil adhered>
Change to a new filter.

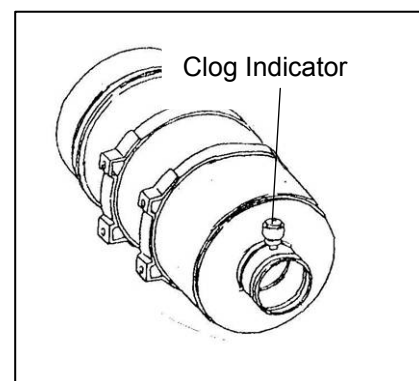

- Clog Indicator
The clog indicator to display clog in the air filter element is incorporated to air filter unit.
- Whenever RED SIGNAL appears in the indicator window, clean or change element regardless of operation hour.
- After cleaning or changing finishes, push the reset button to release the RED SIGNAL.

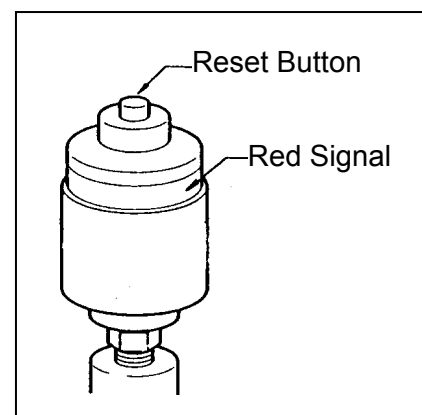

(4) Drain water in the Water Sedimentor

Check	Startup
Clean	Every 500 hours

When the Float (red) is coming up to 20mm from the bottom, drain the water.

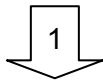

1 Turn the Fuel Lever to CLOSE.

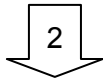

2 Turn the ring nut counterclockwise and remove the cup and Gauze Filter.



3 Dispose water or dirt.

When dirt is adhered to the Gauze Filter, clean the filter by compressed air.



4 Reinstall in the reverse order.

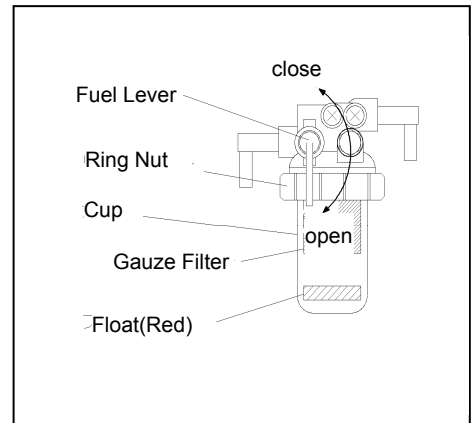

<Caution>

- Be sure to confirm that there is no dirt on O RING, when installing the cup.
- Be sure to confirm that there is no fuel leakage from the water sedimentor, by turning the fuel lever to OPEN.

(5) Drain water in fuel filter

Drain	Every 200 hours
Change	Every 500 hours

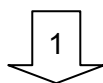

1 Turn the Fuel Lever on the Water Sedimentor to CLOSE.

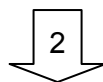

2 Remove the Fuel Filter by filter wrench.

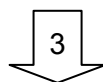

3 Dispose the water in the Fuel Filter.

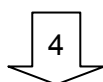

4 When changing the Fuel Filter, smear the oil to the Gasket slightly.

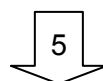

5 Put the filter by hand until the Gasket touches the seal and turn the filter at 2/3 turn by filter wrench.

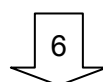

6 Turn the Fuel Lever on the Water Sedimentor to CLOSE.

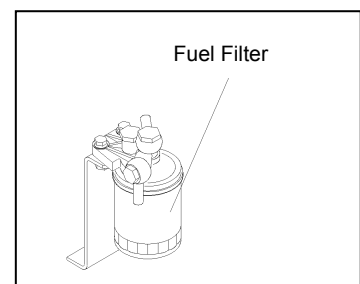

<Caution>

- Be sure to confirm that there is no fuel leakage in the fuel line by running the engine.
- When a filter wrench is unavailable, please get in touch our authorized distributor or our service division to get.
- Be sure to wipe out the spilled fuel in the fuel line when removing the fuel filter.
- Fuel Filter Part No.

Isuzu Part No.	8943940791
----------------	------------

(6) Change filter in the magnet pump for automatic fuel extraction

Change	Every 1000 hours
--------	------------------

1 Turn the cover, located at the bottom of pump, counter-clockwise and remove filter.

2 Reinstall a replacing filter in the reverse order.

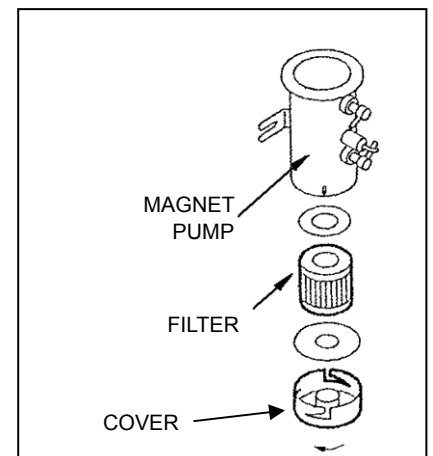

<Caution>

- Put a tray under the lever in order to catch spilled fuel when changing filter.
- Extract the air in fuel line after filter changing finishes. (Refer to 『9-2.During Operation』 .)
- Ensure that there is no fuel leakage after reinstallation.
- Filter Part No.

Isuzu Part No.	8943370220
----------------	------------

(7) Drain water in fuel tank

Drain	Every 200 hours
-------	-----------------

1 Remove the Fuel Drain Plug.

2 Turn the Fuel Drain Lever to OPEN.

3 Draining the water out, turn the Fuel Drain Lever to CLOSE.

4 Tighten the Fuel Drain Plug.

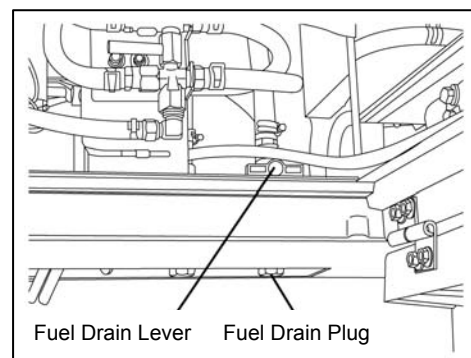

(8) Change coolant

Change	2 years or 1000 hours
--------	-----------------------

1 Remove the radiator plate first and open the radiator cap cover.

2 Remove the radiator cap.

3 Loosen the radiator drain lever and the drain plug on the engine side.

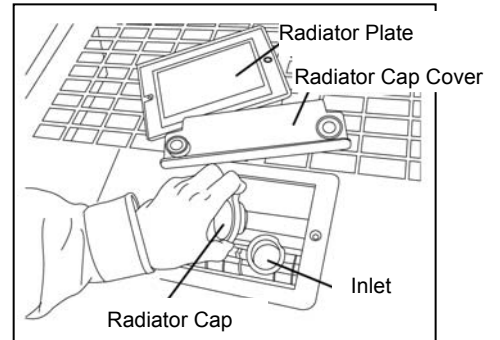

4 After draining finishes, tighten the radiator drain lever and the drain plug on the engine side.

5 Drain the sub tank stay and drain coolant in the sub tank.

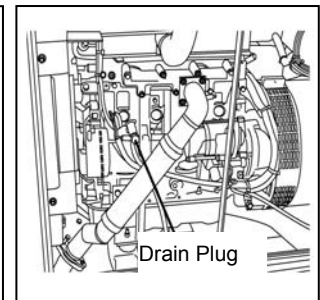
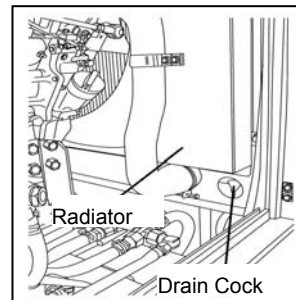

6 Reinstall the sub tank and fill coolant up to MAX level.

7 Fill coolant into radiator up as far as the water inlet level.

8 Tighten the radiator cap.

9 Close the radiator cap cover and Reinstall the radiator plate.

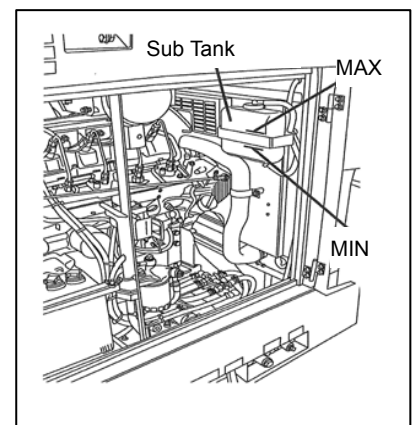
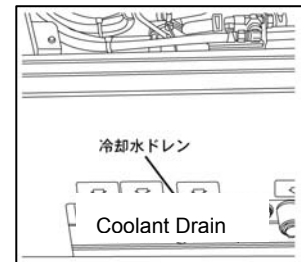

<Caution>

- Refer Coolant to 『8-2. Checking Coolant/Water』 .

11 Long-term storage



Danger : Electric Shock/Injuries

- Before performing any equipment check or maintenance, stop the engine, and remove the engine key. The person performing the maintenance should always keep the key.



Caution : Fire/Injuries

- Temperature around muffler and exhaust can get extremely high levels. Keep any inflammable items (such as fuel, gas, paint, etc.) away from the equipment.
- When checking engine, always stop the engine, and keep away from fire. Wait until the engine cools down, before performing any checks.



Caution : Fire

- Always wipe any drip of Diesel fuel or oil. Do not use this equipment when a leak is found. Repair the equipment before use.

(1) Storage Procedures

If the generator will not be used for more than two months, perform the following maintenance and storage procedures.

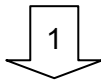

Remove battery.

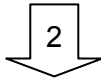

Change engine oil.

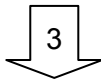

Drain fuel in the fuel tank and fuel filter.



Clean all parts, cover the equipment, and store it in the place where dust and humidity are less as possible.

<Caution>

- Charge the removed battery once a month.
- Refer to the owner's manual for engine about the engine storage/maintenance.

(2) Stacking



Danger : Injuries

If you have to stack two generators at warehouse, always proceed with the following steps.

- Ensure that there is no dent on bonnet, loose bolt or no bolt in the equipment.
- Always place the equipment horizontal on a flat and stable surface to be enduring for the total weight, and to keep the equipment from sliding.
- When lifting the equipment, always use a lift hook.
- Always place ties (sleepers) on the marked points in the lower equipment firstly and then stack the upper equipment on it. All the ties should be the same size (dimension) and longer than the width of the lower generator.
- Do not stack more than 2 units. The lower generator should be bigger than the upper generator in size and weight.
- Do not operate the stacking/stacked equipment.

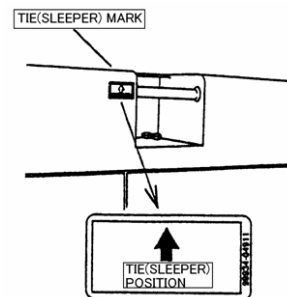
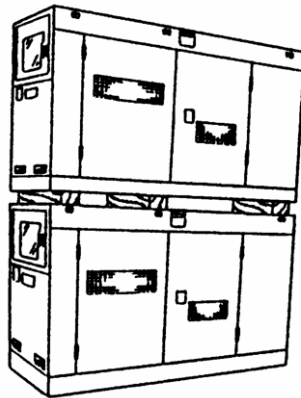

12 Troubleshooting



Danger : Electric Shock

- Do not operate the equipment, if the equipment or you are wet.
- Before performing any equipment check or maintenance, stop the engine.



Caution : Injuries

- When performing equipment check and maintenance, always stop the engine.



Caution: Fire/Burns

- Never get fire near to the equipment.
- When checking engine oil or changing oil, always stop the engine, and wait until the engine cools down.
If you open either the oil gauge or the oil filler cap during operation, hot oil may cause some injury.

Follow the guideline below, when performing any troubleshooting. If you cannot resolve the problems by this troubleshooting guide, contact our authorized distributor or our engineering section to request the repair.

Symptom		Presumable Cause	Action
Engine does not start	Starter motor does not drive or speed is low.	<ol style="list-style-type: none"> 1. Battery Isolator is OFF 2. Battery output is weak 3. Battery is deteriorated 4. Battery terminal is OFF or loose 5. Battery terminal is corroded 6. Starter switch or relay is defective 7. Starter motor is defective 	<ol style="list-style-type: none"> 1. Turn Battery Isolator to ON 2. Check / battery liquid/ or Charge 3. Change battery 4. Fix / Tighten terminal 5. Clean terminal 6. Ask our distributor to repair 7. Ask our distributor to repair
	Starter motor drives but engine does not start	<ol style="list-style-type: none"> 1. Fuel is insufficient 2. Fuel filter is clogged 3. Gauze filter is clogged 4. Water is interfused in fuel line 5. Air is interfused in fuel line 6. Poor piping connection to external fuel tank 7. Fuel tank selector lever (3-way valve) position is wrong 8. Fuel cut solenoid (motor) does not work 	<ol style="list-style-type: none"> 1. Add fuel 2. Clean / Change fuel filter 3. Clean / Change gauze filter 4. Drain water in water separator, fuel filter or fuel tank 5. Extract the air 6. Check piping connection 7. check lever (3-way valve) 8-1. Check / Change fuse 8-2. Check / Change fuel cut solenoid
	<Ambient temperature falls down below zero>	<ol style="list-style-type: none"> 1. Fuel is frozen 2. Water in fuel line is frozen 3. Pre-heater is defective 	<ol style="list-style-type: none"> 1. Use winterized fuel 2. Drain water in fuel line 3. Ask our distributor to repair
Engine starts but stalls immediately	<ol style="list-style-type: none"> 1. Fuel filter is clogged 2. Gauze filter is clogged 3. Water is interfused in fuel line 4. Air is interfused in fuel line 5. Poor piping connection to external fuel tank 6. Air filter element is clogged 7. Lubricant oil is insufficient 	<ol style="list-style-type: none"> 1. Clean / Change fuel filter 2. Clean / Change gauze filter 3. Drain water in water separator, fuel filter or fuel tank 4. Extract the air 5. Check piping connection 6. Check / Change air filter element 7. Supply lubricant oil 	
Engine oil pressure is low	<ol style="list-style-type: none"> 1. Lubricant oil is insufficient 2. Oil filter is clogged 3. Oil Pressure switch is defective 4. Oil pressure meter is defective 5. Wrong oil is used 	<ol style="list-style-type: none"> 1. Supply lubricant oil 2. Change oil filter 3. Ask our distributor to repair 4. Ask our distributor to repair 5. Change to proper kind and viscosity oil 	
Overheated	<ol style="list-style-type: none"> 1. Engine thermostat is defective 2. Water temp sensor is defective 3. Water temp meter is defective 4. Fan belt tension is weak 5. Coolant is insufficient 6. Radiator core is clogged 	<ol style="list-style-type: none"> 1. Ask our distributor to repair 2. Ask our distributor to repair 3. Ask our distributor to repair 4. Check / Adjust fan belt 5. Check / Supply coolant 6. Clean radiator core 	

Black smoke comes out from Muffler	<ol style="list-style-type: none"> 1. Air filter element is clogged 2. Fuel injection nozzle is defective 3. Improper fuel is used 	<ol style="list-style-type: none"> 1. Check / Change air filter element 2. Ask our distributor to repair 3. Change to clean fuel
White smoke comes out from Muffler	<ol style="list-style-type: none"> 1. Too much or too little oil to cylinder 2. Water is interfused in fuel line 3. Fuel injection nozzle is defective 4. Coolant temperature is too low 5. Engine thermostat is defective 	<ol style="list-style-type: none"> 1. Ask our distributor to repair 2. Drain water in water separator, fuel filter or fuel tank 3. Ask our distributor to repair 4. Warm-up driving is needed 5. Ask our distributor to repair
Pointer (hand) does not move in voltage meter	<ol style="list-style-type: none"> 1. Voltage meter is defective 2. AVR is defective 3. Disconnected circuit, loose terminal or departed 4. Initial exciter is defective 5. Alternator is defective 	<ol style="list-style-type: none"> 1. Ask our distributor to repair 2. Ask our distributor to repair 3. Ask our distributor to repair 4. Ask our distributor to repair 5. Ask our distributor to repair
Pointer (hand) does not goes up to the rated voltage	<ol style="list-style-type: none"> 1. Voltage meter is defective 2. AVR is defective 3. Voltage regulator dial is defective 4. Frequency is low 	<ol style="list-style-type: none"> 1. Ask our distributor to repair 2. Ask our distributor to repair 3. Ask our distributor to repair 4. Ask our distributor to repair
Pointer exceeds the rated voltage	<ol style="list-style-type: none"> 1. Voltage meter is defective 2. AVR is defective 	<ol style="list-style-type: none"> 1. Ask our distributor to repair 2. Ask our distributor to repair
The voltage drops drastically when connecting to load	<ol style="list-style-type: none"> 1. AVR is defective 2. Unbalanced loads sharing to each terminal 3. Wrong frequency is used 4. Loads total exceeds the rated current 	<ol style="list-style-type: none"> 1. Ask our distributor to repair 2. Balance the loads sharing to each terminal 3. Set the switch to the load frequency 4. Decrease the loads to meet the rated output
Cannot turn the breaker to ON	<ol style="list-style-type: none"> 1. The Main breaker positions at between ON and OFF 2. Short circuit on the load 	<ol style="list-style-type: none"> 1. Once turning the lever to OFF, turn it to ON 2. Check the load circuit

13 Generator Circuit Diagram

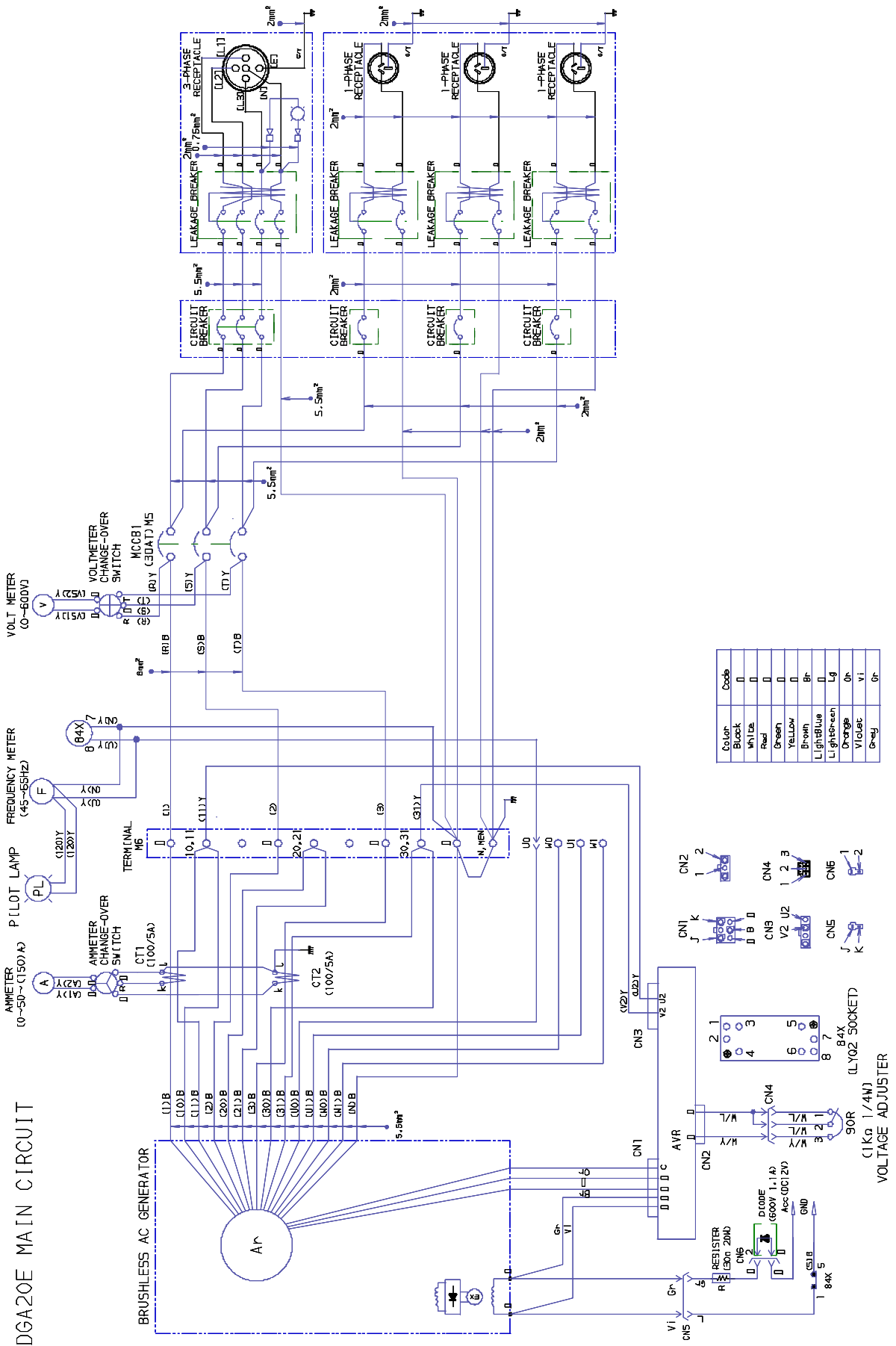

14 Engine Circuit Diagram

DGA20E ENG. CONTROL CIRCUIT

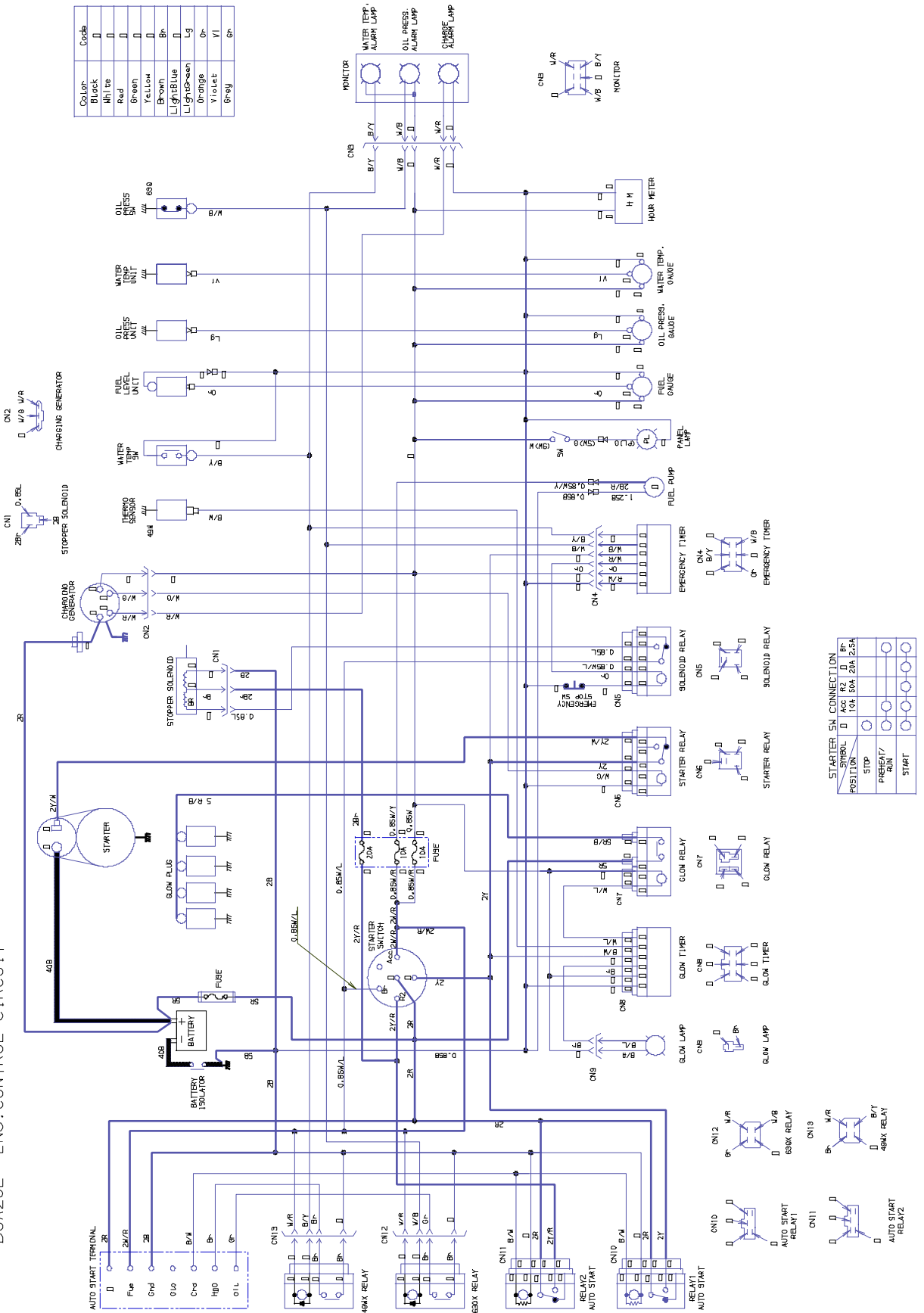

Color	Code
Black	0
White	1
Red	2
Green	3
Yellow	4
Brown	5
Light Blue	6
Light Green	7
Violet	8
Grey	9

STARTER SW CONNECTION	RELAY	RELAY	RELAY	RELAY	RELAY
POSITION	10A	10A	10A	20A	25A
STOP					
PRESTART					
START					

YAMABIKO CORPORATION

7-2 SUEHIROCHO 1-CHOME, OHME, TOKYO 198-8760, JAPAN
PHONE: 81-428-32-6118. FAX: 81-428-32-6145.

shindaiwa