

### 1. Description

The Network Camera supports the network service for a sensor image with progressive scan, which can be monitored on a real-time screen regardless of distances and locations. By using its dedicated program, many users are able to have an access to the Network Camera at once or a single user can monitor various network cameras at the same time. It also enables users to play, store and retrieve a monitoring image by using a PC. All the settings and real-time monitoring screens are also provided through an access to the web.

The Network Camera is fully featured for security surveillance and remote monitoring needs. It is based on the DSP compression chip, and makes it available on the network as real-time, full frame rate Motion JPEG and H.264 (or MPEG-4) video streams.

- **Installation Steps**

Follow these steps to install the network camera on your local network (LAN):

1. Check the package contents against the list below.
2. Connect the Network Camera. See page 3.
3. Set an IP address. See page 5.
4. Set the password. See page 7.

- **Package Component**

The system comes with the following components:

Quantity	Description
1	Camera
1	Installation CD
1	Accessory kit for installing Dome Camera
1	Template sheet
1	Extension connector kit

- **Contents in the installation CD**

1. The Network camera User's Manual
2. The SmartManager User's Manual
3. The NCTitanium User's Manual
4. The SmartManager Installation software
5. The NCTitanium Installation software

**Note:** Check your package to make sure that you received the complete system, including all components shown above.

# Quick Installation Guide

- Layout**

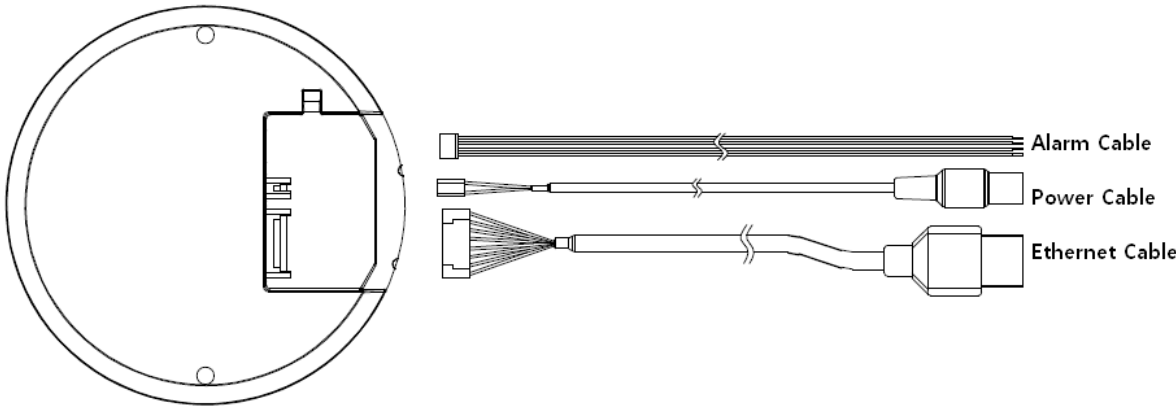

NO	Name	Description
1	Alarm Cable	Cable for Alarm input and output
2	Power Cable	Cable for Power source (DC 12V)
3	Ethernet Cable	Cable for Ethernet

- Camera Dimension**

See the diagrams below for the exact dimension

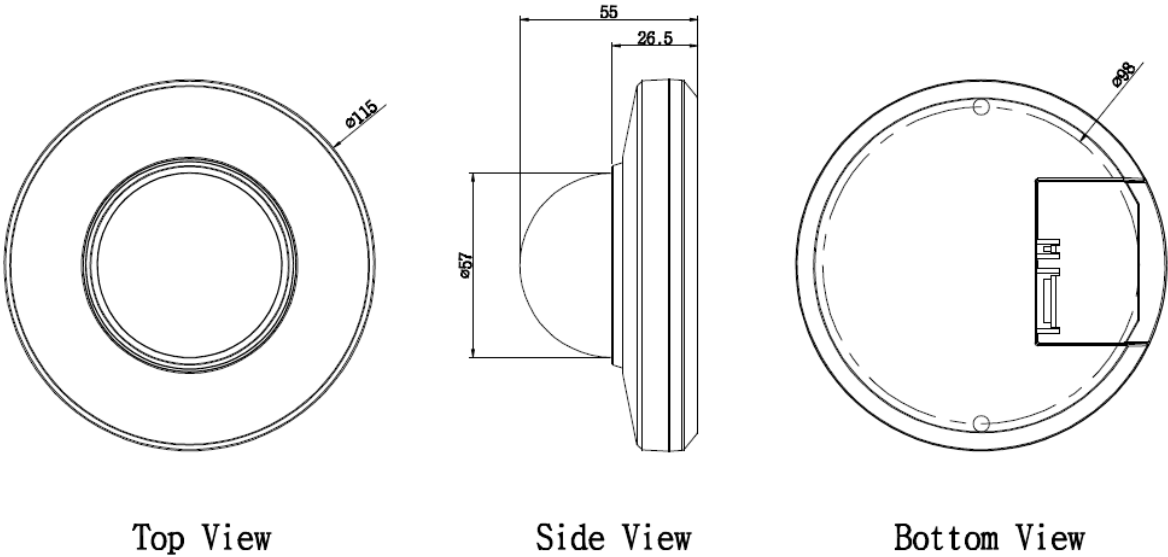

Dimensions Unit: mm

## 2. Installation

### 2.1 Camera Installation

Carefully remove the contents from the box, and verify that nothing was damaged in shipment.

- 1) Make screw holes for camera on the ceiling with Template Sheet.

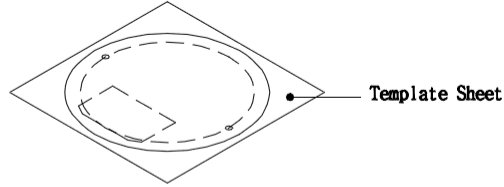

- 2) Disassemble a camera by Camera cover .

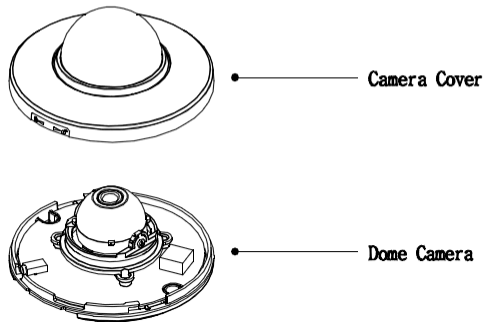

- 3) Fix the Camera Set using Anchors(2x) and Screws(2x) to the ceiling.

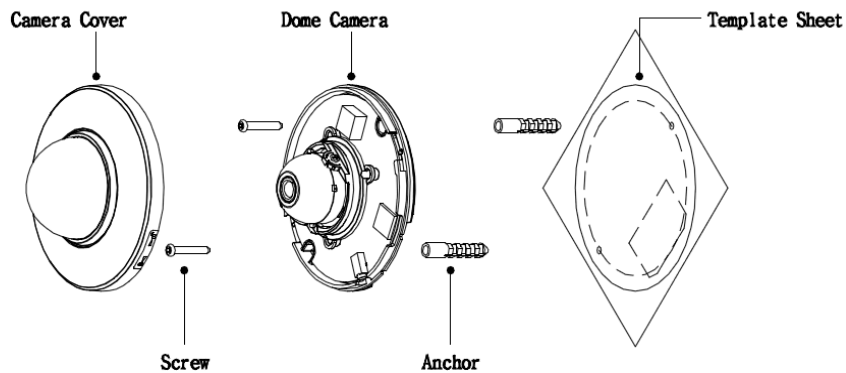

- 4) Assemble Camera Cover to Dome Camera.  
Turn the Camera Cover clockwise to complete installation.

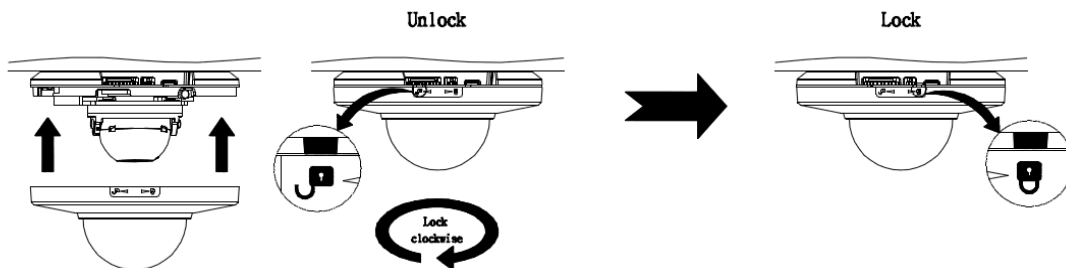

## Quick Installation Guide

- **Connecting to the RJ-45**  
Connect a standard RJ-45 cable to the network port of the network camera. Generally a cross-over cable is used for directly connection to PC, while a direct cable is used for connection to a hub.
- **Micro SD memory slot**  
Insert the SD memory card.
- **Connecting the Power**  
Connect the DC 12V power adaptor to the camera.
- **Connecting the Wireless using WPS function**

Follow steps for a proper operation.

1. Make sure your AP (Access Point) and Operating System support WPS (Wi-Fi Protected Setup) functions. WPS enables easy setup with compatible APs.
2. Press the WPS button. You can then see the Status window.
4. Press and hold down the WPS button on your AP (some router/AP will have a virtual button on their management software instead). Refer to your AP's documentation for details using its WPS functions

When WPS configuration is done, wireless connectivity will be established and the security encryption, such as WEP or WPA-PSK, will be synchronized with the AP. As for IP setting, the camera's use of DHCP or static IP is determined by your configuration on the network camera via the web- based configuration of firmware.

Notes:

1. WPS may not work if your AP is configured with a "hidden" SSID.
2. If any WPS-enabled AP is not detected, the camera will search APs for 60 seconds after pressing the WPS button, and if the camera still can not detect an AP after 1 minute, the wireless setup will be cancelled.
3. If a camera is assigned with a fixed IP outside the AP's network segment, wireless setup will fail.
4. A wired connection always has a higher priority, and hence wireless setup will not take effect when the RJ45 LAN port is connected.

## 2.2 Network Connection and IP assignment

The Network Camera supports the operation through the network. When a camera is first connected to the network it has no IP address. So, it is necessary to allocate an IP address to the device with the "Smart Manager" utility on the CD. (Default IP 192.168.30.220)

1. Connect the Network Camera / device to the network and power up.
2. Start SmartManager utility (Start>All programs>SmartManager>SmartManager), the main window will be displayed, after a short while any network devices connected to the network will be displayed in the list.

# Quick Installation Guide

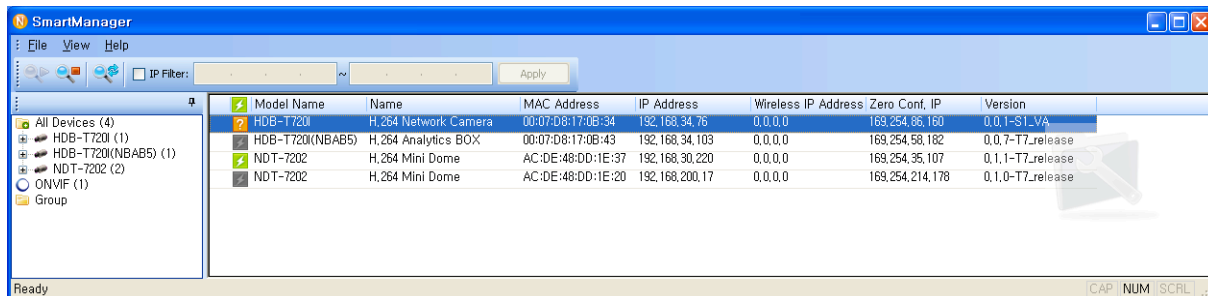

3. Select the camera on the list and click right button of the mouse. You can see the pop-up menu below.

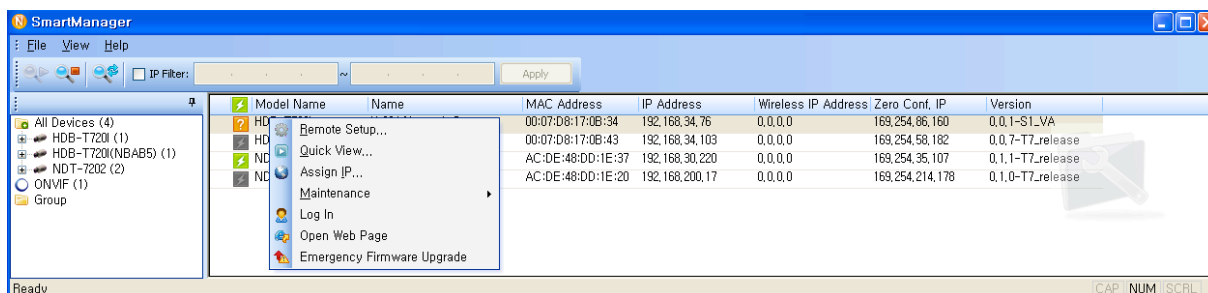

4. Select Assign IP. You can see a Assign IP window. Enter the required IP address.

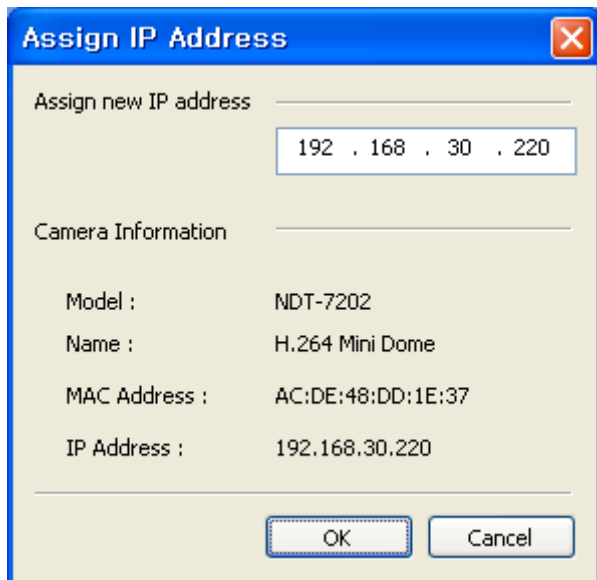

**Note:** For more information, refer to the Smart Manger User’s Manual.

### 3. Operation

The Network Camera can be used with Windows operating system and browsers. The recommended browsers are Internet Explorer, Safari, Firefox, Opera and Google Chrome with Windows.

**NOTE:** To view streaming video in Microsoft Internet Explorer, set your browser to allow ActiveX controls.

#### 3.1 Access from a browser

1. Start a browser (Internet Explorer).
2. Enter the IP address or host name of the Network Camera in the Location/Address field of your browser.
3. You can see a starting page. Click Live View or Setup to enter web page.



4. The network camera's **Live View** page appears in your browser.

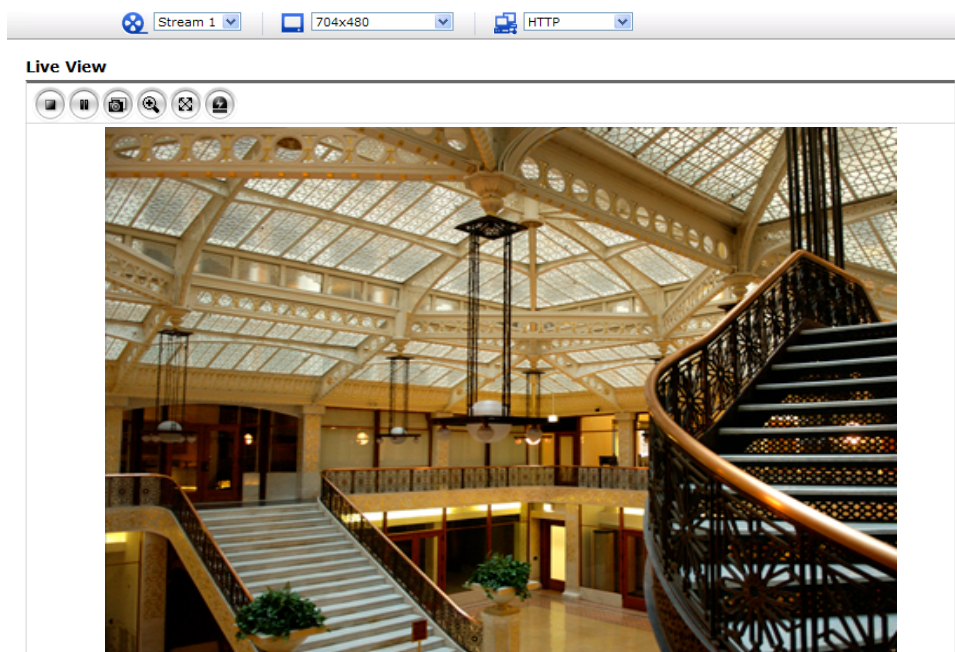

## 3.2. Access from the internet

Access from the internet once connected, the Network Camera is accessible on your local network (LAN). To access the network camera from the Internet you must configure your broadband router to allow incoming data traffic to the network camera. To do this, enable the NAT-traversal feature, which will attempt to automatically configure the router to allow access to the network camera. This is enabled from Setup > System > Network > NAT.

For more information, please see "3.5.4 System>Network>NAT" of User's Manual.

## 3.3 Setting the admin password over a secure connection

To gain access to the product, the password for the default administrator user must be set. This is done in the "Admin Password" dialog, which is displayed when the network camera is accessed for the setup at the first time. Enter your admin name and password, set by the administrator.

Note: The default administrator username and password is "admin". If the password is lost, the Network Camera must be reset to the factory default settings. See "3.8 Resetting to the Factory Default Settings".

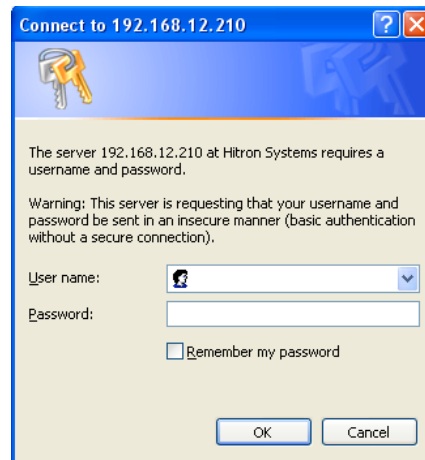

## 3.4 Live View Page

The live view page comes in seven screen modes: 1920x1080, 1280x1024, 1280x720, 720x480(576), 640x480, 352x240(288) and 320x240. Users are allowed to select the most suitable one out of those modes. Please, adjust the mode in accordance with your PC specifications and monitoring purposes.

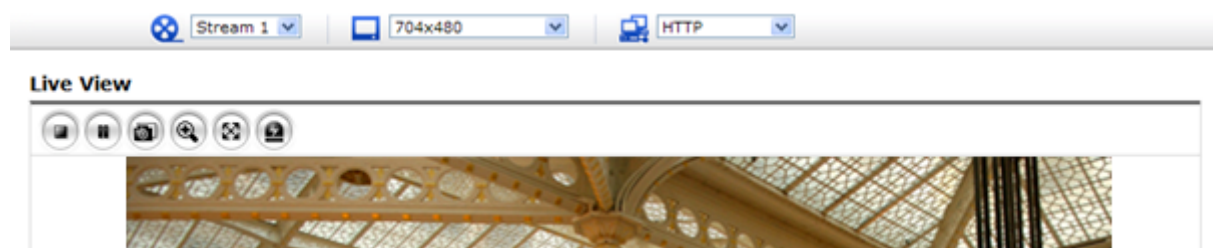

## 1) General controls



Live View Page



Search & Playback Page



Setup Page



Help Page



The video drop-down list allows you to select a customized or pre-programmed video stream on the live view page. Stream profiles are configured under Setup > Basic Configuration > Video & Image. For more information, please see "3.5.1 Basic Configuration > Video & Image" of User's Manual.

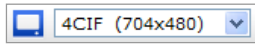







The resolution drop-down list allows you to select the most suitable one out of video resolutions to be displayed on live view page.



The protocol drop-down list allows you to select which combination of protocols and methods to use depends on your viewing requirements, and on the properties of your network.

## 2) Control toolbar

The live viewer toolbar is available in the web browser page only. It displays the following buttons:

-  The Stop button stops the video stream being played. Pressing the key again toggles the start and stop. The Start button connects to the network camera or start playing a video stream.
-  The Pause button pause the video stream being played.
-  The Snapshot button takes a snapshot of the current image. The location where the image is saved can be specified.
-  The digital zoom activates a zoom-in or zoom-out function for video image on the live screen.
-  The Full Screen button causes the video image to fill the entire screen area. No other windows will be visible. Press the 'Esc' button on the computer keyboard to cancel full screen view.
-  The Manual Trigger button activates a pop-up window to manually start or stop the event.

## 3) Video Streams

The network camera provides several images and video stream formats. Your requirements and the properties of your network will determine the type you use.

The Live View page in the network camera provides access to H.264, MPEG-4 and Motion JPEG video streams, and to the list of available video streams. Other applications and clients can also access these video streams/images directly, without going via the Live View page.



### 3.5 Network Camera Setup

This section describes how to configure the network camera, and is intended for product Administrators, who have unrestricted access to all the Setup tools; and Operators, who have access to the settings for Basic, Live View, Video & Image, Audio, Event, and System Configuration.

You can configure the network camera by clicking Setup in the top right-hand corner of the Live View page. Click on this page to access the online help that explains the setup tools

When accessing the Network Camera for the first time, the "Admin Password" dialog appears. Enter your admin name and password, set by the administrator.

Note: If the password is lost, the Network Camera must be reset to the factory default settings. See "3.6 Resetting to the Factory Default Settings".

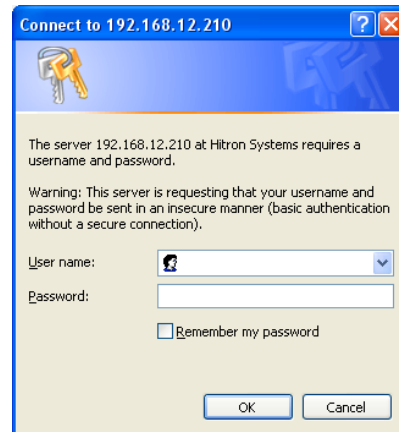

### 3.6 Resetting to the factory default settings

To reset the Network Camera to the original factory settings, go to the Setup>System> Maintenance web page (described in "3.5.4 System > Maintenance") or use the Reset button on the network camera, as described below:

- **Using the Reset Button**

Follow the instructions below to reset the Network Camera to the factory default settings using the Reset button.

1. Switch off the Network Camera by disconnecting the power adapter.
2. Uncover camera dome and press and hold the Reset button while reconnecting the power.
3. Keep the Reset button pressed during about 2 seconds.
4. Release the Reset button, and wait for the Status LED to turn off.
5. The network camera resets to factory defaults and restarts after completing the factory reset.

**CAUTION:** When performing a Factory Reset, you will lose any settings you have saved.  
(Default IP 192.168.30.220)

### 3.7 More Information

For more information, please see the Network Camera User's Manual, which is available on the CD included in this package.