



X-Series  

---

Installer Manual





## Contents

1.	Keypads .....	5
2.	Introduction to the IDS X-Series .....	9
	Features of the IDS X-Series .....	9
3.	Installation and Wiring .....	10
	Installation Requirements .....	11
	End-of-Line Resistors .....	11
	Box Tamper Input .....	11
	Connecting the Telephone Communicator - Advanced .....	11
	Programmable Outputs .....	11
	Key-Switch or Remote Control Unit .....	11
	Installing a Zone Expander Module.....	12
	IDS Remote Receiver.....	12
	Radio Transmitter Connection .....	12
4.	Hardware Default Switch.....	12
5.	Enrolling Keypads and Other Bus-wired Peripherals .....	12
	Replacing a Damaged Keypad / Bus-wired Peripheral .....	13
	Defaulting Keypads .....	13
6.	Event Log .....	14
7.	Access Codes .....	14
	Normal User Code.....	14
	Master User Code .....	14
	Maid's Code (Arm to Disarm Code).....	14
	Duress Code .....	14
	Installer Code .....	14
	Maintenance Code.....	14
	Download Code .....	14
8.	How to Read Location Values.....	15
9.	Programming of the Panel.....	15
	Entering Installer or Maintenance Mode .....	16
	Programming Standard Locations .....	16
	Programming Extended Locations .....	17
	Using the String Method .....	17
	Using Sub-locations.....	18
	Programming a Location or Sub-location with a Bitmap.....	18
10.	Programming Location Summary .....	19
	Zones .....	19
	Global Setup .....	22
	Daylight Savings .....	26
	Miscellaneous – Advanced.....	27
	Communications Setup - Advanced .....	28
	Phone Numbers .....	31
	Zone Properties .....	33
	No Movement – Advanced .....	34
	Security Codes .....	37
	Partition Options.....	38
	Delays .....	40
	Options to Configure Keypads .....	40
	Wireless Integration Options .....	42
	Reporting Codes - Advanced .....	45
	Global Reporting Codes .....	45
	Zone Reporting Codes.....	48
	Partition Reporting Codes.....	50

	User Reporting Codes .....	51
	Programmable Outputs .....	53
	Output Disarm Clear .....	53
	Partition Event Driven Outputs - Advanced .....	54
	Zone Programmable Output Events.....	55
	Output Pulse Timing - Advanced.....	56
	Output Scheduling On Time - Advanced .....	57
	Output Scheduling Off Time - Advanced .....	57
	Output Scheduling On/Off Days - Advanced .....	58
	Event Reporting Options - Advanced .....	59
11.	Voice Module .....	61
12.	Keypad Information.....	62
13.	Panel Information.....	62
14.	User Options .....	63
15.	Appendix .....	64
16.	Hardware Identification .....	67
17.	Serial Communication Jumper Settings.....	67
18.	Index .....	68
19.	Cross Reference Lookup .....	69
20.	Programming Quick Reference Guide .....	70
21.	Trouble Display.....	71

## Figures

Figure 1:	Connection Diagram without Tamper per Zone.....	10
Figure 2:	How Telephone Numbers Work.....	32
Figure 3:	Paging Indication on the Classic Keypad .....	38
Figure 4:	Paging Indication on the Curved Keypad.....	38
Figure 5:	IDS/Duevi Wireless PCB:.....	42
Figure 6:	Distinguishing 512k boards from previous versions.....	67
Figure 7:	Serial communication jumper location .....	67

## 1. Keypads

### CLASSIC LCD KEYPAD

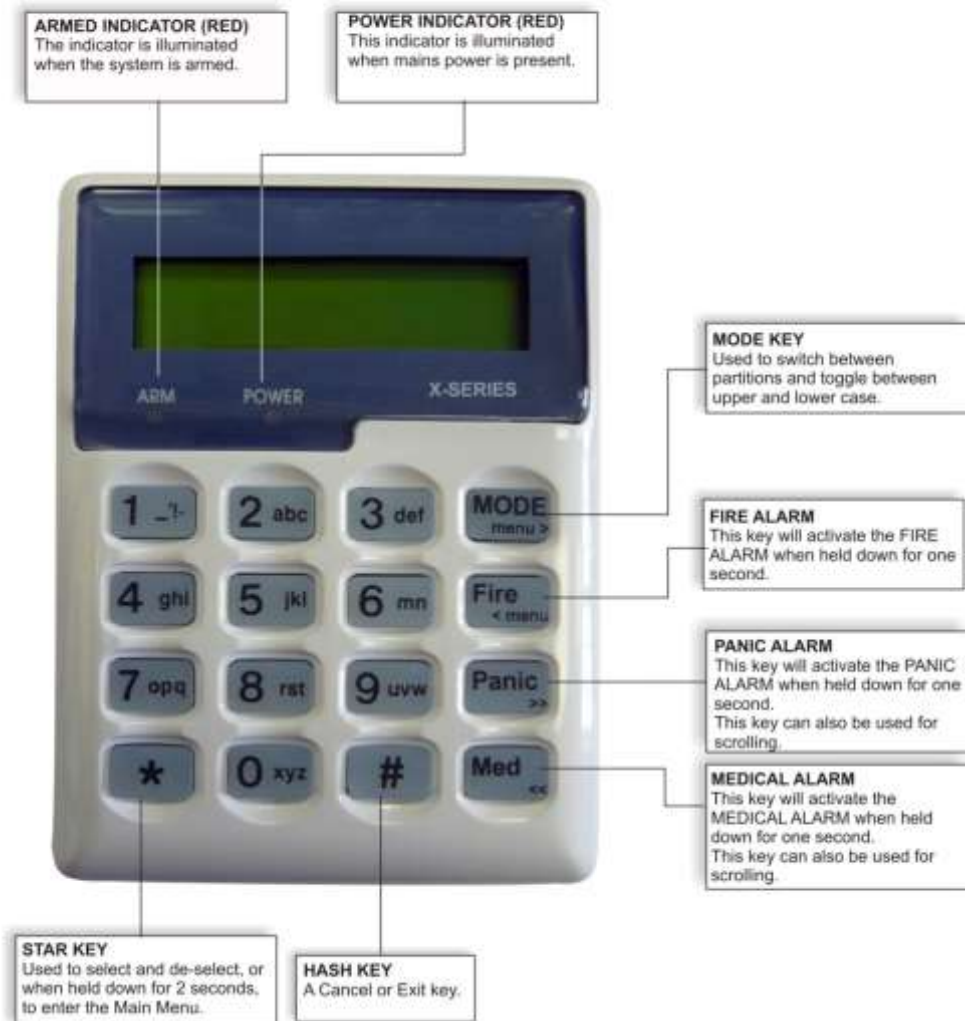

# CURVE LCD KEYPAD



# CLASSIC LED KEYPAD

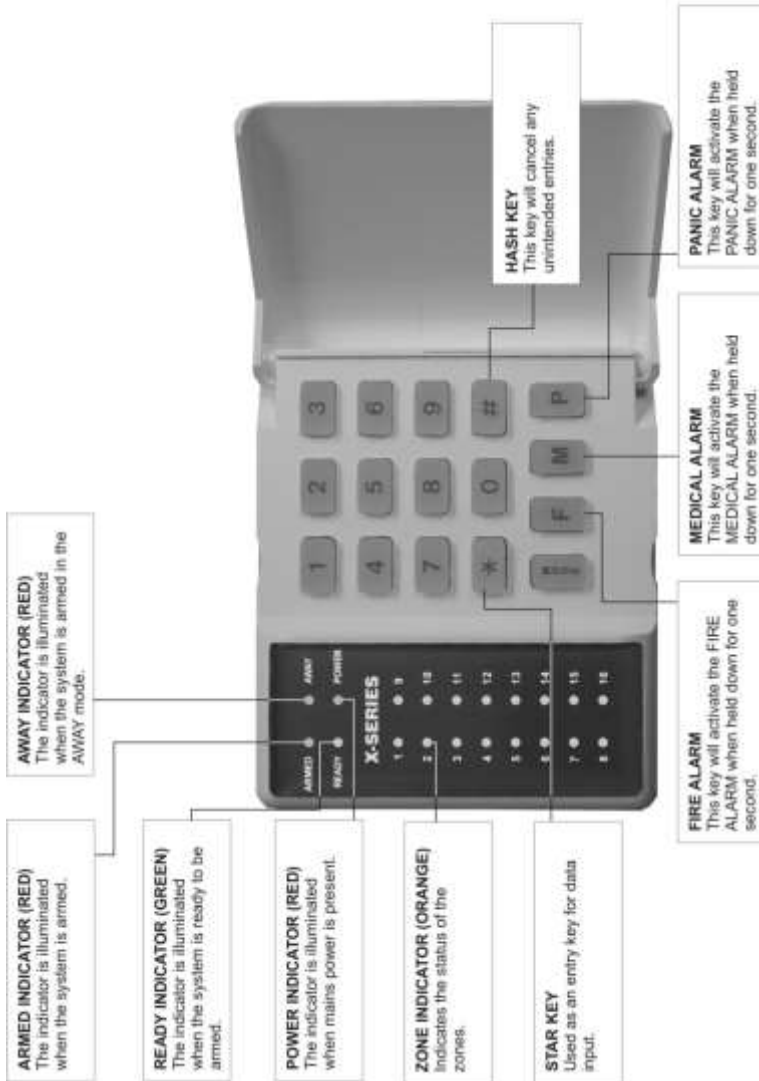

# CURVE LED KEYPAD

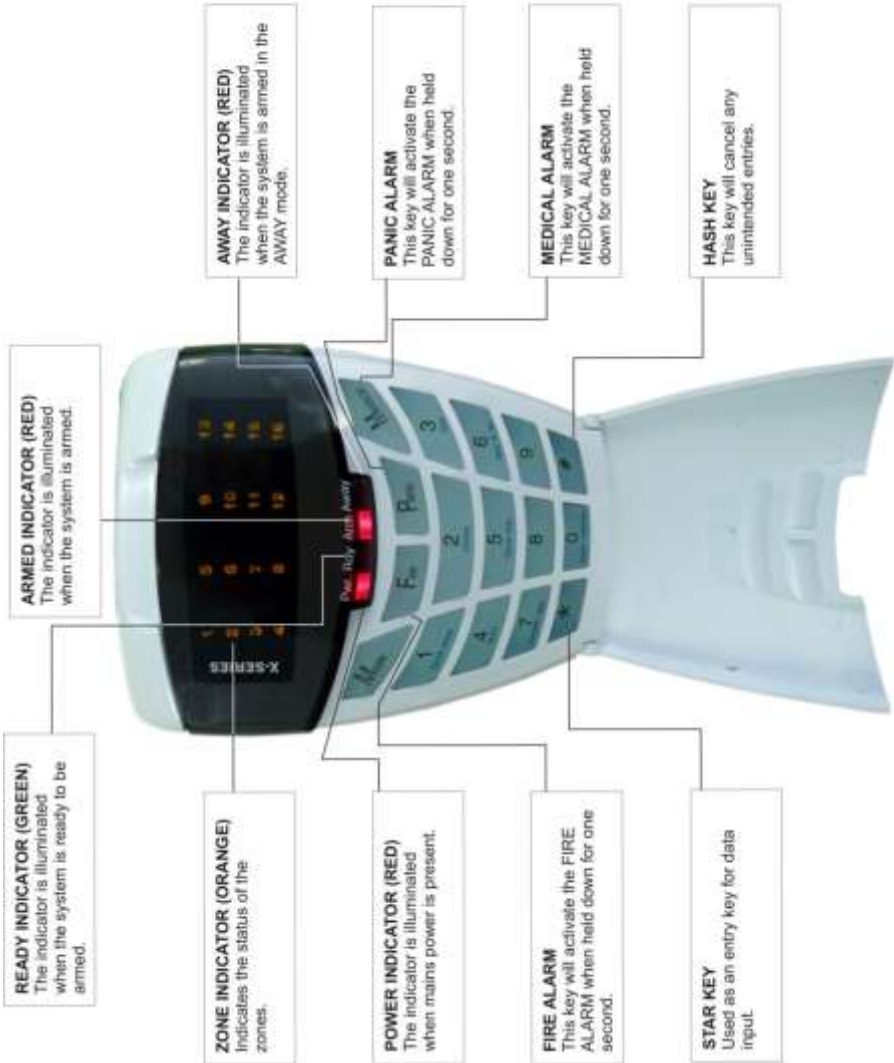



## 2. Introduction to the IDS X-Series

Thank you for purchasing an IDS Alarm Panel.

The IDS X-Series alarm is a versatile, Bylaw 25 compliant, expandable Alarm Panel. It comes in two versions, X16 and X64. Both have up to 8 partitions and can have 8 keypads. The X16 can be expanded from 8 to 16 zone and the X64 from 8 to 64 zones. Most features are configurable and may be programmed directly through a keypad or via serial PC connection or telephone system, using the IDSwift Download Software and appropriate modem (P/N: 860-36-0001).

There are up to 64 programmable burglary zones on the X64, 16 programmable burglary zones on the X16. A dedicated panic zone, monitored siren output, auxiliary power output, and 5 onboard programmable outputs expandable to 25 on the X64, which may be programmed to perform various, trigger/switching functions are available.

For correct operation, the IDS X-series panels must be used in conjunction with the specified transformer / battery combination (ask your sales representative for a copy of the IDS Power Budget spreadsheet to identify your needs) and appropriate peripheral sensors and signalling devices.

### NOTE:

X-SERIES products are not compatible with any previous IDS products, such as the IDS816 and IDS1632.

## Features of the IDS X-Series

### Zones and Partitions:

- 8 onboard zones, expandable to 16 onboard zones with a X-series 8-zone Plug-in Expander (P/N: 860-06-X-08PI) – A very cost-effective 16 zone solution
- Further expandable to 64 zones with the use of up to 6 bus-wired X64 8-zone Unpowered Expander modules (P/N: 860-06-X-08S) or 8 keypad zones - 1 per keypad
- All zones can be expanded with wireless receivers to receive signals from the Duevi range of wireless detectors. All wireless zones are fully supervised.
- The system can also have a hybrid of wired and wireless zones totaling 64 zones for the X64 and 16 zones for the X16.
- 8 partitions
- 4 stay profiles per partition

### Users:

- 128 users
- Options to set user codes as Master, Duress, Maid, Arm only, Disarm only or Output Trigger.

### System Options:

- Tamper reporting per zone using double end-of-line resistors (12K and 4K7)
- 5 programmable outputs on the Alarm Panel, expandable to 25 when using zone expanders (2 per expander), and keypads (1 per keypad)
- Event log (1000 events) date and time relative
- Auto arm/disarm capability per partition and by day of the week.
- No movement auto arm and medical reporting
- Panel firmware installer upgradable via serial data cable
- Telephone communicator that supports Ademco, FBI, Silent Knight, Contact ID, and SIA
- Fax defeat/answering machine override
- Dual reporting provides for duplicated reporting to two independent central base stations
- Split reporting to report to either 1 of 2 dual reporting number pairs
- Comprehensive lightening protection
- Dynamic battery self-test
- Low battery monitoring and cut-out circuit
- Dual power supply, with an independent battery charging circuit, means more onboard power for simplified alarm installation
- Voice module support (860-06-X64-0412). Only version "D" hardware and above.

### 3. Installation and Wiring

Please refer to:

**Figure 1: Connection Diagram without Tamper per Zone** and familiarise yourself with the following sections.

**\*The kick start jumper must be in-circuit when using only a battery (i.e. no AC). Simply short the pins out with a screwdriver, or use a jumper. Remove the short/jumper once the Panel Status LED lights up (indicating power up), as leaving it on disables the low battery cut-out.\***

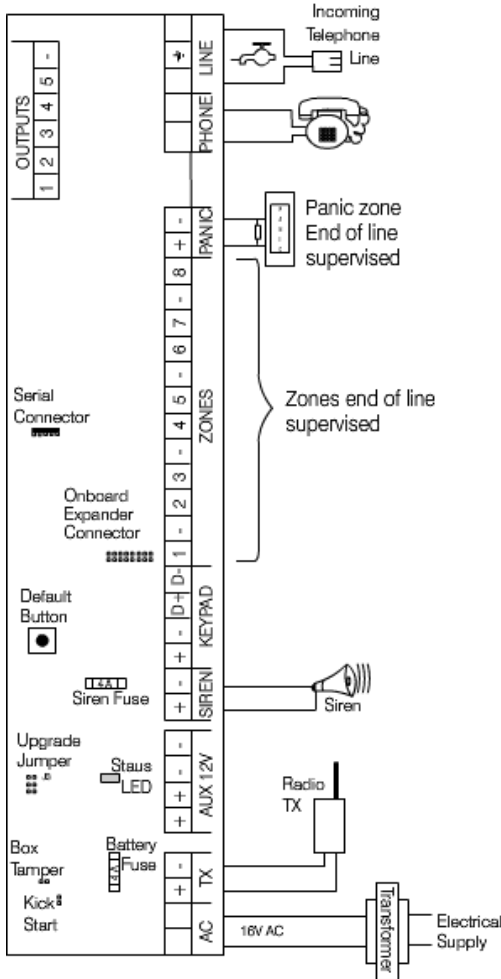

**Figure 1: Connection Diagram without Tamper per Zone**

## Installation Requirements

- A suitable transformer with an output voltage of 16 Vac  $\pm 10\%$  with a 32VA minimum rating must be used. A 48VA transformer is recommended.
- A 12V sealed lead acid battery with a minimum capacity of 7AH must be used. The backup period after mains failure will depend on the number of keypads, sensors, and bus-wired peripheral devices connected to the system.
- Connect a 12V self-driven siren or piezo siren (not a horn speaker) to the siren output.
- The panel can supply a total continuous current of 750mA to bus-wired peripheral devices such as keypads, remotes, receivers, passives etc; from Aux 12V terminals.

## End-of-Line Resistors

- All zones, including Panic zones, are end-of-line supervised.
- All zones, whether they are used or unused, need to be terminated with a 3K3 resistor (resistor colour-code is orange, orange, red, gold).
- For maximum security, the end-of-line resistor must be placed inside or as close to the sensor as possible.
- For tamper by zone, 4K7 and 12K end-of-line resistors must be connected instead of a single 3K3 resistor.
- If the panel is unarmed and a tamper condition occurs, the siren will not sound but a tamper condition will be reported if it is enabled to do so. See Table 40 to enable/disable this option.
- If the panel is armed and a tamper condition occurs, an audible alarm will register, and a tamper condition AND zone violation will be reported.

## Box Tamper Input

The box tamper input does not require an end-of-line resistor, but does require a normally closed contact. The panel is shipped with the box tamper input bypassed with tamper. To use it, remove the jumper and connect a normally closed contact onto the terminals. Refer to Figure 1: Connection Diagram without Tamper per Zone for the box tamper position on the Alarm Panel.

## Connecting the Telephone Communicator - Advanced

Refer to: Figure 1: Connection Diagram without Tamper per Zone

For optimum lightning protection, connect a low resistance earth to the communicator earth input.

- Always connect the telephone communicator in line seizure mode and never in parallel with the telephone.
- Ensure the telephone receiver is connected to the communicator terminals marked "phone" and the incoming line to the terminals marked "line".

## Programmable Outputs

An IDS Relay Board (P/N: 861-004) must be used when any device requiring a current greater than 50mA is connected to a programmable output. The programmable output circuitry consists of a 12V source with a 56  $\Omega$  series resistor. Current sink is via a 1,000  $\Omega$  resistor to ground. The maximum output voltage is 13.6Vdc. The maximum output current is 50mA. Programmable outputs are primarily connected for radio transmitter. However, they are also used for connecting, LEDs, sirens, bus-wired peripherals, etc.

## Key-Switch or Remote Control Unit

A key-switch, (not recommended) or non-IDS remote receiver may be connected to any zone to allow remote arm/disarm and remote panic capability.

- When using a key-switch or remote control unit, a 3K3 resistor must be connected between the zone input and ground.
- Use only a spring-loaded momentary key-switch or non-latching remote control unit.

## Installing a Zone Expander Module

When installing a zone expander module refer to the document supplied with the module. Note that up to 6 bus-wired, 8-zone expander modules (P/N: 860-06-X-08S) and 1 plug-in expander (P/N: 860-06-X-08PI) may be added to the IDS X64 Alarm Panel. Zones 9-16 are reserved for the Plug-in Zone Expander module which may be used on the X16 as well.

## IDS Remote Receiver

Up to 4 IDS Remote Receivers (P/N: 860-07-X02-DI) may be connected to the keypad Bus. Using this facility allows remote arming and disarming of the panel while providing user identification for a maximum of 128 remotes.

For a full list of features and benefits of the receiver, please see the manual that comes with it.

## Radio Transmitter Connection

When connecting a radio transmitter, use the TX terminal provided on the panel to supply power to the transmitter. This output is protected by a 4 Amp fuse. This will also help protect the battery by cutting power to it to stop it from being drained

## 4. Hardware Default Switch

Use the hardware default switch (refer to Figure 1) to return the panel to its factory default settings.

The procedure to default the panel is as follows:

1. Remove the battery and AC power from the panel
2. If you are only using a battery make sure that the kick-start jumper is in circuit
3. Hold down the default switch and reapply power to the panel (battery or AC)
4. Wait for the Panel Status LED to flash
5. Release the default switch
6. Remove the kick-start jumper, if one was used
7. Defaulting is complete once the Panel Status LED starts flashing

The effects of applying the default:

1. Factory default values are restored to all locations
2. All attached keypad IDs are defaulted
3. The event log is not defaulted
4. The "system default" event is logged to the event log

**NOTE:** The hardware default switch can be disabled in location 35.

See also: Defaulting the Panel or Master User Code – location 0

## 5. Enrolling Keypads and Other Bus-wired Peripherals

Keypads must be enrolled on the system before they can be used. Keypads are allocated an ID in the order in which they are enrolled. To enrol a keypad:

1. Wire it to the keypad BUS
2. Power the system up
3. Press the [#] key

Repeat this process with the remaining keypads where more than 1 keypad is used. The first keypad enrolled will have an ID of 1, the second enrolled will have an ID of 2, the third an ID of 3 etc.

**NOTE:**

- All the zone and LEDs will flash on a keypad that does not have an ID.
- The POWER and READY LEDs will be on for a keypad that has an ID and no zone violations.
- Only the POWER LED will be on for a keypad that has an ID with a zone violation. The LED for that zone will also flash.

## Trouble shooting

If the ID process, for an LED keypad, has failed zones 1-8, and zones 9-16 will flash alternately. At this point press the **[#]** key to retry.

If the flashing persists, try the following steps:

1. Check all wiring
2. Check that you have not exceeded 8 keypads on the bus
3. Contact the IDS helpdesk for further support

**NOTE:** To enrol other devices (IDS Remote Receivers or Zone Expanders); consult the installation manuals for those devices. The IDS X64 Alarm Panels can accept 6 zone expanders and 4 remote receivers.

## Replacing a Damaged Keypad / Bus-wired Peripheral

To replace a damaged device (non-dipswitch – like a keypad):

1. Disconnect only the faulty device.
2. Program a value of **[4]** into location 0 to free up all redundant IDs (previously unallocated IDs remain free), wait for approximately 10 seconds then continue to step 3.
3. Connect the replacement device and enrol it – by pressing **[#] for keypads** – it will now be enrolled in the first available address.

### NOTE:

- If other devices are disconnected (or damaged), at the time of performing step 2, their addresses will also be freed. Any new devices being enrolled will automatically be allocated addresses beginning from the lowest free address.
- When you free up the ID of the damaged unit, the panel settings, relevant to the ID, will be defaulted too. Therefore, the keypad will need to be re-added to a partition.
- If a new keypad was enrolled, go to location 243 to check the keypad's ID (1-8).

### Solution

If there are problems with device IDs on a complex installation, do not assign IDs randomly, rather, at the end of the installation, default all device IDs and then enroll them in sequence.

To re-enrol a Zone Expander or a Remote Receiver (dipswitch); consult the installation instructions for the particular device.

## Defaulting Keypads

### To default the ID of an individual keypad:

1. Remove power to the keypad (or the whole panel if easier).
2. Hold down the **[1]** and **[3]** keys simultaneously.
3. Restore the power.
4. Wait for three seconds and then release the keys (there will not be a beep).
5. All the keypad LEDs will flash simultaneously indicating that the keypad has been de-registered
4. Wait for five seconds and ensure that the Panel Status LED on the panel is flashing, if the power from the panel was removed.
5. Press the **[#]** key to allocate a new ID to the defaulted keypad. Keypad IDs are allocated incrementally.
6. The ID of any (correctly registered) keypad can be viewed in location 243 from the keypad of interest.

### To default the ID of ALL keypads:

1. Enter a value of **[3]** into location 0.  
**[INSTALLER CODE] [\*] [0] [\*] [3] [\*]**
2. On pressing the final **[\*]**, wait a few seconds and ALL the keypad LEDs will begin flashing. (Do NOT press the **[#]** key at the end of this sequence, unless you wish the keypad you are using to be registered in the first address).
3. Re-enrol all keypads by pressing the **[#]** key on each keypad – in the CORRECT sequence to ensure that keypad zone and partition allocation is as required by the user.

## 6. Event Log

A comprehensive log of the 1 000 most recent events is retained in the non-volatile EEPROM. The log may be retrieved using the up/download software, or on the LCD keypad. (See the LCD Keypad Manual or User Manual to see how to view the event log).

The IDS Download Software is available for Inhep account customers, at no cost, to collect your event logs via direct serial download, or via a modem.

## 7. Access Codes

The panel supports up to 128 users. The user codes can have various properties assigned to them. These properties allow the user codes to have different functions.

### Normal User Code

A normal user code is used to arm/disarm the panel, and to access certain user options.

### Master User Code

When assigned to a user, this property allows the user to act as a master user. The Master User Code has full access to programming all the user options. For a full list of user programmable options, refer to the X-Series User Manual.

### Maid's Code (Arm to Disarm Code)

This property may be used to limit access to the premises. A Maid's Code will only disarm the system if the same code was used for arming. If armed with a code other than this code, the system will view an attempt to disarm using a Maid's Code as an invalid entry. Any valid user code will disarm the system if it has been armed with a Maid's Code.

### Duress Code

This property denotes a user code as a special code to be used in the unique situation where an intruder forces one to disarm the system "under duress".

When the **[DURESS CODE]** is entered, the Alarm Panel disarms normally - however a DURESS REPORTING CODE is transmitted to the monitoring company to inform them that you have been forced to disarm the Alarm Panel by an intruder.

It is advisable to choose a code that can easily be remembered by all family (or staff) members.

### Installer Code

The Installer Code (location 197) is used by the installer to program and configure the Alarm Panel. It has full access to all installer mode menus as listed in this manual.

### Maintenance Code

The Maintenance Code (location 199) acts in a similar way to the Installer Code, but it has limited access to installer menus. The default Maintenance Code is 8888, or 888888 for a 6-digit code. This code is used to access the following locations:

Locations 17 - 18	Siren Time & Delay	Locations 20 - 22	Keypad Lockout and Sleep
Locations 25 - 31	Daylight Savings	Locations 171 - 173	No Movement, Auto Arm
Locations 174 - 176	No Movement, Medical Alarm	Locations 180 - 190	Auto Arm Times

The assignment of this property to a user allows the relevant user to perform certain "maintenance" tasks that would ordinarily require the use of the installer code.

### Download Code

The Download Code, location 198, (in conjunction with the Installer Code) is required for download access via the IDS Download Software. The default Download Code is 9999 or 999999 for a 6-digit code.

**NOTE:** It is possible to program location 34 to either allow or disallow defaulting of the Download Code.

## 8. How to Read Location Values

Values within a data program location will be displayed by the zone LEDs in binary coded decimal format i.e. zone LEDs 1-4 indicate units (ones) and zone LEDs 5-8 indicate tens (tens), and so on.

To read a binary value on the keypad, add up the values represented by each lit LED as shown in Table 1

**Table 1: Values Represented by each Zone LED**

Zone LED	Value	Digit	Zone LED	Value	Digit
Zone 1	1	Units	Zone 9	1	Hundreds
Zone 2	2		Zone 10	2	
Zone 3	4		Zone 11	4	
Zone 4	8		Zone 12	8	
Zone 5	1	Tens	Zone 13	1	Thousands
Zone 6	2		Zone 14	2	
Zone 7	4		Zone 15	4	
Zone 8	8		Zone 16	8	

### EXAMPLE:

Imagine the following zone LEDs are on: Zone 1, Zone 3 and Zone 5.

Units are represented by the sum of Zone 1 and Zone 3 (i.e. 1 + 4).

Tens of units are represented by the value of Zone 5 (i.e. 1 x ten).

Therefore, the displayed value is  $(1+4) + (10) = 15$ .

Values within a time program location are displayed in a similar format as per Table 2.

**Table 2: Binary Coded Decimal Four Digit Display**

Zone LED	Calculation	Unit	Zone LED	Calculation	Unit
1	(x 1 = 1)	M	9	(x 1 = 1)	S
2	(x 2 = 0)		10	(x 2 = 2)	
3	(x 4 = 4)		11	(x 4 = 4)	
4	(x 8 = 0)		12	(x 8 = 0)	

Mm:Ss  
= 45:36

5	(x 1 = 1)	m	13	(x 1 = 1)	s
6	(x 2 = 0)		14	(x 2 = 2)	
7	(x 4 = 4)		15	(x 4 = 1)	
8	(x 8 = 0)		16	(x 8 = 0)	

M = LEDs 4 through 1  
m = LEDs 5 through 8  
S = LEDs 12 through 9  
s = LEDs 16 through 13

Using an LCD keypad means that data and time information can be read directly without a need to convert.

## 9. Programming of the Panel

The X-series control panels can be fully programmed using the X-series LED keypad; the system is optimised to use an LCD keypad. The following section describes how programming data is represented in the X-series panels and how to program it, specifically with the LED keypad.

For all programming procedures, the [\*] key functions as the <ENTER> key and the [#] hash key functions as a <CLEAR> or an <EXIT> program key.

Invalid data entries are indicated by means of an error beep consisting of 3 short beeps of the keypad buzzer.

**There are two location categories:**

- Standard locations which are single tiered and do not contain any sub-locations.
- Extended locations, which are double tiered and have strings or sub-locations depending on the installers programming preference.

Both standard and extended locations may contain further sub-categories referred to as bitmapped locations.

For both main categories, clear visual keypad prompts are provided, which aid the programming process.

**NOTE:** When you use the [\*] key to scroll through a bitmapped location, it will scroll through the pages. When using the [\*] key to scroll through numbered locations, it will scroll through the bytes.

- Alpha-numeric locations (location 51 - telephone number), will show 1 digit per press of the [\*] key.
- Numeric locations (location 197 – installers code), will show 2 digits per press of the [\*] key.
- To view how the data is represented, please see Table 1.

Below are various programming symbols you will see throughout the manual:



Indicates programming the standard method



Indicates programming using the string method



Indicates programming a sub-location



Indicates programming a location/sub-location with a bitmap

Where a hexadecimal number must be programmed, use the [MODE] key as per Table 3.

**Table 3: Hexadecimal Values**

Hex Value	Decimal Value	Key Strokes
A	10	[MODE] key then [0] key
B	11	[MODE] key then [1] key
C	12	[MODE] key then [2] key
D	13	[MODE] key then [3] key
E	14	[MODE] key then [4] key
F	15	[MODE] key then [5] key

**NOTE:** The hex values of A-F can be used for account codes. Only B-F can be used for phone numbers. This means that for locations 50-54, A is NOT a hex number – but is rather used to CLEAR a telephone number.

### Entering Installer or Maintenance Mode

The following steps show how to enter into installer or maintenance mode.

1. Ensure that all partitions are unarmed.
2. Press the [#] key followed by the [INSTALLER CODE] or the [MAINTENANCE CODE].
3. The default installer code is 9999 or alternatively 999999 should a 6-digit default installer code have been used.
4. Press the [\*] key and a long beep will confirm entry into program mode. If a correct code has been entered, the green READY LED will flash.

**NOTE:** This will not work if the dialler is active at the time, or if one of the partitions are armed.

### Programming Standard Locations



The following steps show how to program standard locations.

1. Ensure the panel is in program mode - the READY LED will be flashing.
2. Enter the [LOCATION NO.] of the program location you wish to view or change.
3. Press the [\*] key, until the beep. The READY LED will become solid and the AWAY LED will flash.
4. The zone LEDs will display the data stored in the program location in binary format.
5. Enter the [NEW DATA] followed by the [\*] key. A long beep will indicate a valid entry and the AWAY LED will turn off. The READY LED will flash.
6. If you do not wish to change the data, press the [#] key. The READY LED will continue flashing and the AWAY LED will turn off.
7. Repeat steps 2 - 5 until all the necessary locations have been programmed.
8. Press the [#] key to exit program mode.
9. The READY LED will stop flashing and the panel will return to the standby mode.

When programming a standard location, any attempt to enter invalid data will result in an error beep (3 short beeps).

The AWAY LED will remain on after the error beeps. Re-enter the correct data. There is no need to press the [#] key.



**EXAMPLE:**

[INSTALLER CODE] [\*] [0] [\*] [VALUE] [\*]

**NOTE:**

When you enter a standard location and press the [\*] key, you will NOT be entering a sub-location – as there is no sub-location to enter. What will happen is that you will scroll through the information in that location. If you enter a digit, you will be changing the information stored in that position of the location, or the location itself.

**EXAMPLE:**

If you want to scroll through all the entries within a location with a LED keypad, you will input the following data:

[INSTALLER CODE] [\*] [LOCATION NO.] [\*] [\*] [\*] [\*], etc.

Scrolling through with the [\*] key will show you all the numbers in a location. At the end of the allowed locations, there will be a long beep to indicate that you are back at entry one of the location.

If you go to location 61 – Primary Account Codes, and then press the [\*] key again followed by a digit, you will be changing just the digit in that string.

## Programming Extended Locations

The following steps show you how to program extended locations. These are locations that have sub-locations. There are two ways to program extended locations: the string method or by using sub-locations.

### Using the String Method

 Using the string method is a fast and efficient way to program the X-series family. By filling in the programming sheets, the installer can first plan the installation, and then very quickly program multiple locations.

1. Ensure that the panel is in program mode - the READY LED will be flashing.
2. Enter the [LOCATION NO.] of the program location that you wish to view or change.
3. Press the [\*] key. The READY LED is on and the ARM and AWAY LEDs will flash.
4. The first sub-location of data on the LED keypad is displayed.
5. Enter the [STRING] for the program locations that you wish to change.
6. Press the [\*] key, a long beep indicates a valid data entry.
7. The ARM and AWAY LEDs turn off and the READY LED will flash for the next location.
8. If you do not wish to change the data within this location, press the [#] key. The READY LED will continue flashing and the ARM and AWAY LEDs will turn off.
9. Repeat steps 2 - 7 until all extended locations have been programmed.
10. Press the [#] key again to exit from program mode.
11. The READY LED will stop flashing and the panel will return to standby mode.

**NOTE:** To view the rest of the string, use the [\*] key to advance one sub-location at a time. At the end of the allowed locations, there will be a long beep to indicate that you are back at entry one of the location. The mode automatically reverts to Sub-location Mode - see “Using Sub-locations”.

When programming using the string method, any attempt to enter invalid data will result in an error beep (3 short beeps).

The AWAY and ARM LEDs will remain on after the error beeps. Re-enter the correct data. There is no need to press the [#] key.

**EXAMPLE:**

[INSTALLER CODE] [\*] [1] [\*] [01020404040404] [\*]

## Using Sub-locations



Sub-location programming is the classic IDS programming method. It is a personal choice as to which method works for the individual installer.

1. Ensure that the panel is in program mode - the READY LED will be flashing.
2. Enter the **[LOCATION NO.]** of the program location that you wish to view or change.
3. Press the **[\*]** key. The READY LED is on and the ARM and AWAY LEDs will flash.
4. Enter the **[SUB-LOCATION NO.]** (after you have programmed your location) for the program location that you wish to view or change.
5. Press the **[\*]** key. The READY LED will remain on. The ARM LED will change from flashing to steady, with the AWAY LED continuing to flash, indicating sub-location mode.
6. Enter the **[NEW DATA]** followed by the **[\*]** key. A long beep will indicate a valid entry. The READY LED is on. The ARM and AWAY LEDs will flash.
7. If you do not wish to change the data within this sub-location, press the **[#]** key. This takes you back to the locations programming section. The READY LED is on and the ARM and AWAY LEDs will flash.
8. Repeat steps 5 - 6 until all sub-locations at the current location have been programmed.
9. Press the hash **[#]** key to exit from the current location, the ARM and AWAY LED will turn off and the READY LED will continue flashing.
10. Repeat steps 2 to 9 until all extended locations have been programmed.
11. Press the **[#]** key again to exit from program mode.
12. The READY LED will stop flashing and the panel will return to standby mode.

When programming a sub-location, any attempt to enter invalid data will result in an error beep (3 short beeps).

The AWAY and ARM LEDs will remain on after the error beeps. Re-enter the correct data. There is no need to press the **[#]** key.

### EXAMPLE:

**[INSTALLER CODE] [\*] [1] [\*] [1] [\*] [1] [\*] [2] [\*] [2] [\*] [3] [\*] [4] [\*]**

### NOTE:

When you enter a location containing sub-locations and press the **[\*]** key, you will initially enter the first sub-location. Each time you press the **[\*]** key you will jump to the next sub-location. If you enter a digit, you will be changing the information stored in that sub-location itself. At the end of the allowed sub-locations, there will be a long beep to indicate that you are back at the first sub-location.

## Programming a Location or Sub-location with a Bitmap



A bitmapped location allows the installer to program multiple panel features within a single location. This is achieved by using the individual zone LEDs to indicate which features are enabled or disabled. By referring to the appropriate location reference tables, the installer can view the entire selection of features associated with that location.

1. Ensure that the panel is in program mode - the READY LED will be flashing.
2. Enter the **[LOCATION NO.]** of the program location that you wish to view or change.
3. Press the **[\*]** key. The READY LED is on. The AWAY LED flashes whilst in bitmap programming mode.
4. Each LED represents a specific state of a feature. A lit zone LED indicates that a feature is enabled. An unlit LED indicates that a feature is disabled.
5. To toggle a selected feature ON or OFF, press the corresponding LED zone number followed by the **[\*]** key.
6. Once a complete selection of features has been configured, press the **[#]** key to exit.

When programming a location/sub-location with a bitmap, any attempt to enter invalid data will result in an error beep (3 short beeps).

The LED zone number will not change its state.

### EXAMPLE:

Location 16 allows the installer to enable up to twelve trouble conditions that may be displayed.

Upon entering program mode and viewing the contents of location 16, it will be noted that the enabled trouble condition LEDs will be on.

To enable the Communications Fail Trouble Display (indicated by zone 2 LED) press the **[2]** key followed by the **[\*]** star key. A long beep will indicate a valid entry and the zone 2 LED will turn on indicating that Communications Fail Trouble Display has been enabled. Continue selection (or de-selection) of the desired trouble conditions. Once a final selection has been made, press the **[#]** key to exit the location. The AWAY LED will turn off and a long beep will indicate the return to location entry mode.

## 10. Programming Location Summary

A detailed description of each location and its options follow.

### LOCATION 0 Defaulting the Panel or Master user Code

 This location allows you to default the panel, user codes and their properties, and bus-wired peripherals. Refer to Table 4 for the values, that can be programmed, and their actions.

**[INSTALLER CODE] [\*] [0] [\*] [VALUE] [\*]**

**Table 4: Defaulting Data**

Value	Action
0	Will reset all locations to the factory default values. (Master User Code 1234) and all keypad IDs will be defaulted.
1	Will default the Primary Master User Code back to 1234 - or 123456 if 6 digits are being used. Master User Code properties will also be defaulted.
2	Defaults ALL user codes and their properties.
3	Defaults ALL keypads.
4	Remove Missing Devices. Any missing devices (keypads, for example), will have its address freed up, making its address available for a new device when it is enrolled. This MUST be performed when replacing a faulty device. (You must wait for 15 seconds from device failure or removal.)
5	Default "Central Monitoring Mode". Defaults telephone numbers, dialing options, reporting options, reporting code options and sets some options not to factory settings. (Implemented in vers.2)
6	Default "Private Reporting mode". (sets some options not to factory settings) (Implemented in vers.2)
7	Defaults all wireless zones and settings

## Zones

### Location 1 – 8 Individual Zone Type Setup

These locations allow you to program the zone types for zones 1-64. The zones are divided into 8 zones per location. After the zone type is programmed for zones 9 through 64, they will need to be assigned to a partition before being enabled.

Refer to Partition Options to see how to add zones to partitions and what options are available.

Each location represents a set of 8 zones:

- Location 1 zones 1-8 (X8)
- Location 2 zones 9-16 (X16)
- Location 3 zones 17-24 (X64)
- Location 4 zones 25-32 (X64)
- Location 5 zones 33-40 (X64)
- Location 6 zones 41-48 (X64)
- Location 7 zones 49-56 (X64)
- Location 8 zones 57-64 (X64)

Refer to Table 5 for available zone types.

#### NOTE:

- If you require a panic zone whose status can be viewed on a keypad, Do NOT use the dedicated panic for this purpose, as it cannot be viewed on a keypad.
- Zones 1-8 are onboard zones.
- Zones 9-16 are plug-in expander zones.
- Zones 17-64 are expander zones. (supported only by X64)

**Table 5: Zone Types**

Value	Zone Type
00	<p><b>DISABLED</b> A zone violation of a Disabled zone is ignored by the Alarm Panel and will not be indicated on the keypad.</p>
01	<p><b>PRIMARY ENTRY/EXIT ZONE</b> Violations of an Entry/Exit zone are ignored during the exit delay period of the arming procedure. Violating an Entry/Exit zone when armed will initiate the entry delay period. If a valid User Code is not entered before the entry delay period expires, an alarm condition will be registered. Failure to exit through an Entry/Exit zone after arming will cause the panel to Stay Arm. This zone may also function as an Entry/Exit zone that is COMMON to two partitions. In such a case, should a user violate this zone and then disarm this partition, the OTHER partition will re-arm after the entry delay.</p>
02	<p><b>FOLLOWER ZONE</b> A Follower zone is not monitored during the Entry/Exit delay period; therefore it will not cause a violation. This allows the user to enter/exit via the Follower zone. A Follower zone will behave as an Instant zone while the panel is armed and an Entry/Exit zone is not violated prior to violation of the Follower zone.</p>
03	<p><b>PANIC/PRIORITY ZONE</b> Regardless of whether the panel is armed or not, a violation of a Priority zone will cause the Alarm Panel to register a panic condition. This zone type CANNOT be bypassed.</p>
04	<p><b>INSTANT ZONE</b> Violation of an Instant zone will cause the Alarm Panel to register an alarm condition.</p>
05	<p><b>ARM/DISARM ZONE</b> Violation of an Arm/Disarm zone will cause the panel to toggle between (away) armed and disarmed. It is typical to connect a momentary key-switch, or non-latching remote control unit to this zone. <b>NOTE:</b> A zone must be added to a partition in order for it to arm.</p>
08	<p><b>SECONDARY ENTRY/EXIT ZONE</b> The Secondary entry delay will be activated if this zone is violated while the panel is armed.</p>
09	<p><b>Instant Fire Zone (New)</b> Zone triggers on the first violation and triggers a standard fire alarm signal</p>
10	<p><b>FIRE ZONE</b> Violation of a Fire zone will cause the siren to sound regardless of whether the panel is armed or not. The siren will sound intermittently (one second on, one second off). For correct operation, a programmable output programmed as a fire detector power output must be used to control power to the fire detector (refer to Table 36)</p>
11	<p><b>TAMPER ZONE</b> Violation of a Tamper zone will be reported to the base station regardless of whether the panel is armed or disarmed. If the panel is armed, the siren will sound.</p>
12	<p><b>24 HOUR ALARM ZONE</b> Regardless of whether the panel is armed or not, a violation of a 24 Hour Alarm zone will cause the Alarm Panel to register a panic condition.</p>
13	<p><b>WARNING ZONE</b> Violation of a Warning zone will cause the siren to beep. The violation is logged in the event log but it is not reported to the base station. Warning zones may be included and will be counted when used as part of the cross-zone.</p>
14	<p><b>PUSH TO ARM ZONE</b> Violation of a Push to Arm zone during the exit delay will immediately arm the panel.</p>
15	<p><b>OUTDOOR INSTANT ZONE</b> Violation of an Outdoor Instant zone will cause the panel to register an alarm condition. <b>NOTE:</b> This is a reporting code and it functions in the same way as zone type 04.</p>

**How to program using the string method:**



To program 8 zones at a time, fill in a row with the corresponding zone types (2 digits per type, found in Table 5) and enter these values as one long 16-digit string for location 1. This method can be used for the remaining 56 zones by noting that location 2 references zones 9 to 16, location 3 references zones 17 to 24, etc.

I.e. To program the defaulted zone types (Table 6) for the first 16 zones use the following:

```
[INSTALLER CODE] [*]
[1] [*]                reference zones 1 - 8
[0102040404040404] [*]
[2] [*]                reference zones 9 - 16
[0000000000000000] [*]
```

**How to program using the sub-location method:**



To program zones using the sub-location method, program 1 (as indicated by “[ ]” sub-location (followed by the [\*] key) and then enter the zone type (followed by the [\*] key). Then press the [\*] key again to advance to the next sub-location. For sub-locations, the zone type does not have to be 2 digits, i.e. enter 1 or 01.

To repeat for further zones, enter the second zone number (followed by the [\*] key) and then the zone type (followed by the [\*] key). This can be repeated for all 64 zones.

I.e. To program the defaulted zone types for the first four zones use the following:

```
[INSTALLER CODE] [*]
[1] [*]                reference zones 1 - 8
[1] [*] [1] [*] [*]   zone 1, zone type 1
[2] [*] [2] [*] [*]   zone 2, zone type 2
[3] [*] [4] [*] [*]   zone 3, zone type 4
[4] [*] [4] [*] [*]   zone 4, zone type 4
```

**How to program using the [\*] key to advance:**



A third method to program zones using the star advance method is to enter the location number corresponding to a group of 8 zones you wish to program. Each press of the [\*] key will step through a zone.

I.e. To change zone 12 to an Instant zone, use the following:

```
[INSTALLER CODE] [*]
[2] [*]                reference zones 9 – 16
[*]                   move to zone 10
[*]                   move to zone 11
[*]                   move to zone 12
[4] [*]                zone type 4
```

Table 6 represent the default zone types for the 64 zones represented in 2 different programming methods.

**Table 6: Zone Types in String Format**

Zones	Loc	Sub-loc	As Strings	Zone Type
1 - 8	1	n/a	0102040404040404	ref above table
9 - 16	2	n/a	0000000000000000	All Disabled
17 - 24	3	n/a	0000000000000000	All Disabled
25 - 32	4	n/a	0000000000000000	All Disabled
33 - 40	5	n/a	0000000000000000	All Disabled
41 - 48	6	n/a	0000000000000000	All Disabled
49 - 56	7	n/a	0000000000000000	All Disabled
57 - 64	8	n/a	0000000000000000	All Disabled

**Table 7: Zone Types in Sub-location Format**

Zone	Loc	Sub-Loc	As Sub-locations	Zone Type
1	1	1	01	Entry / Exit
2	1	2	02	Follower
3	1	3	04	Audible Instant
4	1	4	04	Audible Instant
5	1	5	04	Audible Instant
6	1	6	04	Audible Instant
7	1	7	04	Audible Instant
8	1	8	04	Audible Instant

The valid data range is: 00 – 05, 08, 10 – 15.

## Global Setup

### LOCATION 10 Zone Shutdown Count (default = 5)



This location determines the number of times a zone may be violated while the panel is armed before it is automatically bypassed. Disarming the panel will clear all bypassed zones.

The Zone Shutdown Count set here applies to all zones that have option 3 (shutdown zone) enabled in locations 101-164.

**[INSTALLER CODE] [\*] [1] [0] [\*] [ZONE SHUTDOWN COUNT] [\*]**

The valid data range is: 1 – 15.

### LOCATION 11 Programmable Zone Loop Response Time (default = 2)



The zone loop response time is the period of time for which a zone must remain violated before a violation is registered. The time is calculated in 12 millisecond increments starting at 12ms. A partial table between the values of 1 and 255 is shown in Table 8; times not shown on the table can be calculated as per the following example:

$$198 \times 0.012 = 2.38 \text{ seconds.}$$

To program the time into this location, the format is **[SSSS]**.

**[INSTALLER CODE] [\*] [1] [1] [\*] [ZONE LOOP RESPONSE TIME] [\*]**

The valid data range is: 1 – 255.

**Table 8: Loop Response Time Data**

Value	Response Time	Value	Response Time	Value	Response Time	Value	Response Time
1	12 ms	10	120 ms	60	720 ms	180	2.16 seconds
2	24 ms	12	144 ms	75	900 ms	210	2.52 seconds
3	36 ms	14	168 ms	90	1.08 seconds	240	2.88 seconds
4	48 ms	15	180 ms	120	1.44 seconds	255	3.06 seconds
5	60 ms	30	360 ms	150	1.80 seconds	105	1.26 seconds

### LOCATION 12 Cross-zone Delay Time (default = 0030)



This location defines the cross-zone delay timer period in minutes and seconds, and it is used in conjunction with location 13. (This is an advanced location).

To program the time into this location, the format is **[MMSS]**.

**[INSTALLER CODE] [\*] [1] [2] [\*] [MMSS] [\*]**

The valid data range is: 00m00s – 59m59s.

### LOCATION 13 Cross-zone Count (default = 3)



If the panel is armed and the total number of violations of zones programmed as cross-zones (locations 101-164) reaches this count within the time period programmed into location 12, an alarm condition will be registered. Any single zone enabled as a cross-zone, which is violated continuously for the time specified in location 12 will also register an alarm condition.

**[INSTALLER CODE] [\*] [1] [3] [\*] [CROSS-ZONE COUNT] [\*]**

The valid data range is: 1 - 15, with 0 to disable.

## LOCATION 14 Global Options

 This location allows you to configure the global options for the X-series Alarm Panel. Table 9 shows the available options.

**NOTE:** For each enabled option, the corresponding locations that configure that option must also be programmed for correct operation.

See Location 19: Extra Global Options for more global options

**Table 9: Global Options Data**

LED	Default	Action
1	ON	A user assigned to any partition may cancel the siren
2	OFF	Keypad trouble beep
3	OFF	Telephone line monitoring
4	OFF	Keypad beep on successful reporting to the base station
5	ON	Keypad Fire, Medical and Panic keys
6	ON	The display of bypassed and stay zones when armed
7	OFF	Siren delay
8	ON	Box tamper monitoring
9	ON	Siren monitoring
10	OFF	Bus-wired peripheral tamper monitoring*
11	OFF	Onboard dedicated panic– audible
12	ON	Low battery monitoring**
13	ON	Low battery cut-out**
14	OFF	Bypassing with user code
15	OFF	Dedicated panic zone bypassing
16	OFF	Remote transmitters to cancel panic

On = Enable Off = Disable

\* Option 9 in location 16 must be enabled for this to work.

\*\* Option 12 needs to be enabled in order for option 13 to work.

**NOTE:** If mains power is present, then the battery is monitored every 30 minutes.

If mains power is not present, then the battery is monitored every minute. If the battery voltage drops below 10V, then the battery will cut-out if option 13 is enabled. If the battery voltage drops below 11V, then option 12 will be reported if it is enabled.

## LOCATION 15 AC Fail / Restore Reporting Delay (default = 0004)

 In the event of a power failure (although instantly displaying the trouble indication) the panel will wait for this period of time before REPORTING the mains failure to the base station This delay eliminates unnecessary reporting if the AC power is removed for a short time period.

It is important to note that an AC restoral will only be reported if an AC failure was reported first, i.e. the delay period was exceeded. To program the time into this location:

**[INSTALLER CODE] [\*] [1] [5] [\*] [HHMM] [\*]**

The valid data range is: 00h01m – 18h00m.

**Note:** The restoral event is reported and logged within a minute of AC being restored.

## LOCATION 16 Trouble Display Enable

 This location determines which trouble conditions are indicated on the keypad when viewing the trouble display. A trouble condition is indicated by a flashing POWER LED. The POWER LED will only stop flashing once the trouble condition has been cleared. Trouble conditions will be reported if programmed to do so in locations 571 and 572, regardless of whether or not they are enabled for display.

To view, hold down the **[7]** key until the keypad beeps. See “Viewing Trouble Conditions” in the User manual.

**Table 10: Trouble Display Options available for viewing**

LED	Default	Action
1	ON	AC fail trouble display
2	OFF	Reporting communications fail trouble display
3	OFF	Telephone monitoring line trouble display
4	ON	Siren monitoring trouble display
5	ON	Low battery monitoring trouble display
6	OFF	Aux. 12V monitoring trouble display
7	OFF	Engineer's reset trouble display
8	ON	Box tamper trouble display
9	OFF	Bus-wired peripheral tamper trouble display
10	OFF	Bus-wired peripheral fail trouble display
11	OFF	Bus-wired peripheral low power/ battery trouble display
12	OFF	Wireless detector battery trouble
13	OFF	Wireless detector supervision trouble
14	OFF	Wireless detector RF jam trouble
15	OFF	Wireless detector low RSSI trouble
16	OFF	Zone tamper trouble condition

On = Enable   Off = Disable

### Explanation of Trouble Conditions

#### ➤ AC Fail

This occurs when the Alarm Panel does not receive any power from your mains electricity. Check if a power failure has occurred, or your transformer is not plugged in or faulty.  
This trouble condition will only clear once the power has been restored.

#### ➤ Reporting Communications Failure

This occurs when communication to the monitoring company is not successful.  
The event will clear upon exiting the trouble viewing mode.

#### ➤ Telephone Line Monitoring

The causes of this could be a fault, or short, on the phone line; or the phone line could be cut.  
This trouble condition will only clear once the phone line restored.

#### ➤ Siren Monitoring

This can occur when the siren has been removed or the siren fuse on the panel has blown.  
This trouble condition will only clear once the siren has been put back into circuit or the fuse has been replaced.

#### ➤ Low Battery Monitoring

This trouble condition can be caused by a low battery voltage, a dead battery, or no battery. If the battery is there, try charging it. If this not does work, then the battery needs to be replaced.  
This trouble condition will only clear once the battery voltage has been restored.

#### ➤ Aux 12V Monitoring

This trouble condition indicates that the fuse has blown, or that there is a fault  
This trouble condition will only clear once the fault has been restored.

#### ➤ Engineer's Reset

An alarm condition has occurred, the Installer needs to come and clear the condition by entering an installer code. The panel cannot be armed until this has occurred, nor will the trouble condition clear.

#### ➤ Box Tamper

The metal housing where the panel is stored has been opened.  
To clear trouble condition, make sure the door to the housing is closed and then view the trouble condition.



- **Bus-wired Peripheral Tamper**  
This trouble condition indicates that a keypad, remote receiver or bus-wired zone expander has been tampered with.  
To clear this trouble condition, restore the tampered device and then view the tamper.
- **Bus-wired Peripheral Fail**  
The panel has lost communication to one of the peripherals attached to it.
- **Bus-wired Peripheral Low Power / Battery**  
Supply voltage to a peripheral has dropped below the recommended limit.
- **Wireless Device Battery**  
This trouble condition indicates a wireless device's battery needs replacing
- **Wireless Device Supervision**  
A wireless device has gone missing
- **Wireless Receiver RF Jam**  
A signal has been detected on the same frequency which may cause signal loss
- **Wireless Device RSSI**  
RSSI means a wireless device has checked in but the signal strength was very low
- **Tamper**  
A device has reported being interfered with

#### LOCATION 17 Siren Time Out Period (default = 0200)



This siren time out period is the period of time for which the siren will sound after it has been activated.

To program the time into this location, the format is [MMSS].

[INSTALLER CODE] [\*] [1] [7] [\*] [MMSS] [\*]

The valid data range is: 00m01s – 59m59s.

#### LOCATION 18 Siren Delay (default = 0200)



This location sets the siren delay period between when an audible alarm condition is registered and the siren is activated. The alarm condition will however be reported to the base station as soon as it occurs. Panic zones and Fire zones will cause an immediate siren even if siren delay is programmed. Option 7 in location 14 (Global Options) must be enabled for the siren delay to have an effect.

To program the time into this location, the format is [MMSS].

[INSTALLER CODE] [\*] [1] [8] [\*] [MMSS] [\*]

The valid data range is: 00m01s – 59m59s.

#### LOCATION 19 Extra Global Options



This location allows you to configure more global options for the X-series Alarm Panel. Table 11 shows the available options.

**Table 11: Extra Global Options**

LED	Default	Action
1	OFF	Zone violation when wireless supervision loss is detected

On = Enable Off = Disable

#### LOCATION 20 Keypad Lockout Count (default = 4)



If a partition has a keypad lockout enabled, the value entered in this location determines the number of consecutive incorrect codes to activate a keypad lockout. The keypad will remain locked for the time programmed in location 21. Activating a Keypad Panic (or dedicated panic zone or entering a duress code) will unlock the keypad.

Option 4 in locations 221-228 (Extended Partition Options) must be enabled for the keypad lockout count to have an effect.

[INSTALLER CODE] [\*] [2] [0] [\*] [KEYPAD LOCKOUT COUNT] [\*]

The valid data range is: 2 – 16.

**LOCATION 21 Keypad Lockout Time (default = 0030)**

The value determines the period of time for which the keypad will remain locked out if the keypad lockout count programmed into location 20 has been exceeded. After this period has elapsed, a locked out keypad will return to an unlocked state. Keypad lockout is enabled by partition; refer to locations 221-228 for extended partition options, but this period applies to all partitions.

To program the time into this location, the format is [MMSS].

[INSTALLER CODE] [\*] [2] [1] [\*] [MMSS] [\*]

The valid data range is: 00m01s – 59m59s.

**LOCATION 22 Keypad Sleep Delay (default = 0500)**

This location sets the time out period before the keypad enters sleep mode. After the delay period, if there is no keypad activity (on any keypad) the backlighting and all other status and alarm LEDs will turn off.

The following events will bring a keypad out of sleep mode: Zone violations/restorals, Tamper violations/restorals, or key presses.

To program the time into this location, the format is [MMSS].

[INSTALLER CODE] [\*] [2] [2] [\*] [MMSS] [\*]

The valid data range is: 00m01s – 59m59s.

**LOCATION 23 User, Installer & Maintenance Code - Number of Digits (default = 4)**

This location determines whether user, installer and maintenance codes are 4 or 6 digits in length. The value programmed into this location has no effect on the download code, which is always 4-digits in length. Refer to Table 12 to view the defaults for 4-digit and 6-digit codes.

If the code length is changed from 6 to 4, then all user codes are automatically set to their default values as per Table 12. This is to avoid duplicate codes being inadvertently created when they have the same first 4 digits.

**Table 12: Number of Digits Data**

Code	Old four-digit code	New six-digit code
Installer Code	9999	999999
Maintenance Code	8888	888888
Master User Code 1	1234	123456
User Codes 2-128	XXXX	XXXX00

[INSTALLER CODE] [\*] [2] [3] [\*] [NUMBER OF DIGITS] [\*]

The valid data range is either 4 or 6.

**LOCATION 24 Number of Account Code Digits (default = 4)**

This location sets the account code length to either 4 or 6 digits. If the length of your account codes is 4 digits and then they are changed to 6 digits, the last two digits will be set to 0.

[INSTALLER CODE] [\*] [2] [4] [\*] [NUMBER OF DIGITS] [\*]

The valid data range is: 4 or 6.

**Daylight Savings****LOCATION 25 Month to Start Daylight Saving (default = 0)**

Select the month for Daylight Saving to commence, as per Table 13.

**Table 13: Month Data**

Value	Month	Value	Month	Value	Month	Value	Month
0	Disabled	4	April	7	July	10	October
1	January	5	May	8	August	11	November
2	February	6	June	9	September	12	December
3	March						

[INSTALLER CODE] [\*] [2] [5] [\*] [MONTH] [\*]

**NOTE:** If this location is disabled, then by default, locations 26 and 27 will also be disabled. This means that even if you put values into locations 26 and 27, daylight savings will not commence.

**LOCATION 26 Day of Week to Start Daylight Saving (default = 1)**

Select the day of the week for Daylight Saving to commence, as per Table 14.

**Table 14: Day of Week Data**

Value	Day	Value	Day
1	Monday	5	Friday
2	Tuesday	6	Saturday
3	Wednesday	7	Sunday
4	Thursday		

[INSTALLER CODE] [\*] [2] [6] [\*] [DAY] [\*]

**LOCATION 27 Week of Month to Start Daylight Saving (default = 1)**

Select the week of the month for Daylight Saving to commence as per Table 15. To set the last week of each month, set the value to 5.

**Table 15: Week of Month Data**

Value	Day	Value	Day
1	Week One	4	Week Four
2	Week Two	5	Last Week
3	Week Three		

[INSTALLER CODE] [\*] [2] [7] [\*] [WEEK] [\*] The valid data range is: 1 – 5.

**LOCATION 28 Month to End Daylight Saving (default = 0)**

Select the month as per Table 13, to end Daylight Saving.

[INSTALLER CODE] [\*] [2] [8] [\*] [MONTH] [\*]

The valid data range: 1 – 12, with 0 to disable.

**NOTE:** If this location is disabled, then by default, locations 29 and 30 will also be disabled. This means that even if you put values into locations 29 and 30, daylight savings will not start.**LOCATION 29 Day of Week to End Daylight Saving (default = 1)**

Select the day of the week as per Table 14, to disable Daylight Saving.

[INSTALLER CODE] [\*] [2] [9] [\*] [DAY] [\*]

The valid data range is: 1 – 7.

**LOCATION 30 Week of Month to End Daylight Saving (default = 1)**

Select the week of the month as per Table 15, to disable Daylight Saving.

[INSTALLER CODE] [\*] [3] [0] [\*] [WEEK] [\*]

The valid data range is: 1 – 5.

**LOCATION 31 Daylight Saving Time Offset (default = 60)**

Enter the daylight saving time offset that will be in force while daylight saving is enabled.

[INSTALLER CODE] [\*] [3] [1] [\*] [DAYLIGHT SAVING TIME OFFSET] [\*]

The valid data range is: 0 – 250.

**Miscellaneous – Advanced****LOCATION 32 Auto Test Report Interval (default = 7)**

The value programmed into this location determines the duration of time between Automatic System Tests. Input the value as per Table 16.

[INSTALLER CODE] [\*] [3] [2] [\*] [AUTO TEST REPORT INTERVAL] [\*]

**Table 16: Auto Test Interval Data**

Value	Time	Value	Time	Value	Time	Value	Time	Value	Time	Value	Time
0	1H	4	6H	8	2D	12	6D	16	10D	20	14D
1	2H	5	8H	9	3D	13	7D	17	11D		
2	3H	6	12H	10	4D	14	8D	18	12D		
3	4H	7	1D	11	5D	15	9D	19	13D		

**LOCATION 33 Auto Test Time (default = 0010)**

 Enter the time when the auto test will be reported. The format is **[HHMM]** based on a 24-hour clock. (All 4 digits must be entered.)

**[INSTALLER CODE] [\*] [3] [3] [\*] [HHMM] [\*]**

The valid data range is: 00h00m – 23h59m.

**EXAMPLE:**

If a value of **[7]** was programmed into location 32 and **[1400]** was programmed into this location, the auto test would be sent every 7 days at 2:00 pm.

**LOCATION 34 Download Code Default Disable (default = 0)**

 This location allows you to set whether the download code is defaulted back to 9999 in the event that the panel is defaulted. Refer to Table 17 for the values that can be programmed.

**[INSTALLER CODE] [\*] [3] [4] [\*] [DOWNLOAD CODE DEFAULT DISABLE] [\*]**

**Table 17: Download Code Disable Data**

Value	Action
<b>0</b>	Enable Download code defaulting
<b>10</b>	Disable Download code defaulting

**LOCATION 35 Hardware Default Switch Disable (default = 0)**

 This location allows you to select whether the Hardware Default Switch is enabled. Refer to Table 18 for the values that can be programmed. For the detailed operation of this switch, refer to Hardware Default Switch.

**[INSTALLER CODE] [\*] [3] [5] [\*] [HARDWARE DEFAULT SWITCH DISABLE] [\*]**

**Table 18: Default Switch Disable Data**

Value	Action
<b>0</b>	Enable Hardware Default Switch
<b>10</b>	Disable Hardware Default Switch

## Communications Setup - Advanced

The X-series Alarm Panels has the capabilities for dual reporting as well as split reporting. Dual reporting is when an alarm condition is reported to both telephone numbers within a telephone module. The condition will only be considered reported once it has been sent to both numbers.

Split reporting is when the panel has to report to either 1 of 2 dual reporting number pairs. Refer to Table 40 to see the available options for zone split reporting.

**EXAMPLE:**

A monitoring company will have all the alarm conditions reported to base station one. All the trouble conditions will be reported to base station two.

**NOTE:**

- If the system is armed by zone, the system will report a close by **user 129**.
- If the system is armed using the quick arm key **[1]**, the system will report a close by **user 130**.
- If the system is armed using the quick stay key **[5]**, the system will report a close by **user 131**.
- If the system is armed using the stay arm and go key **[6]**, the system will report a close by **user 132**.
- If the system is armed by means of the auto arm function, the system will report a close by **user 133**.
- If the system is armed with the download software, the system will report a close by **user 134**.
- These user numbers are hard coded, and they are used when the above actions are reported to a monitoring company.
- In order for these codes to be reported, option 7 in Table 46 needs to be enabled.

**NOTES ON CONTACT ID:**

If the panel has been programmed to use Contact ID, it will not be necessary to program individual reporting codes. Provision has been made to enable/disable the reporting of certain groups of codes. Any event that relates to a specific zone, or to a specific user, will have the relevant zone/user number appended to the end of the Contact ID reporting code.

**LOCATION 36 Zone Status Verify Time (Default = 10min)**

This is the time a zone is monitored for a restore. If the zone does not restore, the system will wait the time entered in this location before sending another burglary event after the siren has timed out.

Note: Must be enabled in Location 221-228 option 8 and the count must be set in location 37

Data entered as mm:ss.

Valid entry is from 00:01 to 59:59.

The default is 10min.

**LOCATION 37 Zone Status Verify Count (Default =0)**

The number of times a burglary event will be sent if the zone does not restore once the siren times out. After the number in this location is reached the zone will be ignored until it restores.

Data entered as number count.

Valid entry is from 0 to 16.

Default is 0.

**LOCATION 40 Serial Communicator Format**

This is to choose which communication format the serial port must communicate with.

**Table 19: Communications Format Data**

Value	Format Name	Description
0	Ademco Express	Dual Tone HS, DTMF
1	FBI 4 x 2 (With Parity)	1.8kHz TX, 2.3kHz HS, 40PPS
2	FBI 4 x 2 (No Parity)	1.8kHz TX, 2.3kHz HS, 20PPS
3	Silent Knight 4 x 2 Fast	1.9kHz TX, 1.4kHz, 20PPS
4	Silent Knight 4 x 2 Slow	1.9kHz TX, 1.4kHz, 20PPS
5	Contact ID	Dual Tone HS, DTMF
6	SIA Reporting	Bell 103 FSK, HS

TX = Transmit

HS = Handshake

PPS = Pulses per Second

Note: For serial communication: J1 open = direct download closed = serial reporting enabled

**LOCATION 41 Telephone Number 1 Communications Format (default = 5)**

 The value entered into this location selects the primary communication format. Select from Table 19 the value that corresponds to the required format. During communication, the green LED on the PCB will turn on indicating that the panel has taken the telephone off-hook. If programmed accordingly, the keypad will beep after receiving a handshake from the base station. This indicates a successful transmission of data. Refer to Table 19 for the available communication formats.

**[INSTALLER CODE] [\*] [4] [1] [\*] [COMMUNICATIONS FORMAT] [\*]**

The valid data range is: 0 – 6. Refer to table 18.

**NOTE:** Refer to section 0

**LOCATION 42 Telephone Number 2 Communications Format (default = 5)**

 If dual reporting is enabled then this format will be used to report to phone number 2, which belongs to reporting module 1. Refer to Table 19 for the available communication formats.

**[INSTALLER CODE] [\*] [4] [2] [\*] [COMMUNICATIONS FORMAT] [\*]**

The valid data range is: 0 – 8.

**LOCATION 43 Telephone Number 3 Communications Format (default = 5)**

 If dual reporting is enabled then this format will be used to report to phone number 3, which belongs to reporting module 2. Refer to Table 19 for the available communication formats.

**[INSTALLER CODE] [\*] [4] [3] [\*] [COMMUNICATIONS FORMAT] [\*]**

The valid data range is: 0 – 8.

**LOCATION 44 Telephone Number 4 Communications Format (default = 5)**

 If dual reporting is enabled then this format will be used to report to phone number 4, which belongs to reporting module 2. Refer to Table 19 for the available communication formats.

**[INSTALLER CODE] [\*] [4] [4] [\*] [COMMUNICATIONS FORMAT] [\*]**

The valid data range is: 0 – 8.

**LOCATION 45 Communication Delay (default = 0020)**

 This location sets the period of time that the panel will wait before reporting zone violations and restorals. If the alarm is cancelled within this time, violations and restorals will not be reported. Violations will however be logged in the event log. Panic events will be reported instantly – regardless of any selected delay period.

Option 3 in locations 221-228 (Extra Partition Options) must be enabled for the communication delay to have an effect. To program the time into this location, the format is **[MMSS]**.

**[INSTALLER CODE] [\*] [4] [5] [\*] [MMSS] [\*]**

The valid data range is: 00m01s – 59m59s.

**LOCATION 46 Reporting Communications Options**

 The panel may be programmed to report to a single central station (single reporting) or to report to two central stations (dual reporting). Refer to Table 20 for a list of reporting options.

**Table 20: Reporting Communications Options Data**

LED	On / Off	Action
1	ON	Enable Tone Dialling
	OFF	Enable Pulse Dialling
2	ON	Join the Telephone Numbers Together
	OFF	Keep Two Separate Telephone Numbers
3	ON	Enable Dual Reporting
	OFF	Disable Dual Reporting
4	ON	Dial 1 <sup>st</sup> number until all dial attempts are exhausted, then will try the 2 <sup>nd</sup> number
	OFF	Alternate between telephone numbers for the number of dial attempts

Default values are shaded

**NOTE:** You cannot join telephone numbers with dual reporting enabled.

**LOCATION 47 Number of Dial Attempts (default = 6)**

 This location determines the maximum number of dial attempts that the panel will make in order to contact the base station. This applies to any of the four phone numbers programmed into locations 51-54. If this location is disabled, the Alarm Panel will not report to any base stations.

**[INSTALLER CODE] [\*] [4] [7] [\*] [NUMBER OF DIAL ATTEMPTS] [\*]**

The valid range of data: 1 – 9, with 0 to disable.

**LOCATION 48 Download Options**

 This location configures options relating to remote connections made to the X-series panels via the onboard telephone dialler. Refer to Table 21 for the values you can select.

- Fax defeat is useful for downloading when a fax or answering machine is connected to the same phone line as the Alarm Panel. If this feature is enabled, dial the panel and hang up before three rings. Dial the panel again within one minute. The panel will then pick up the call on the first ring thereby preventing the fax / answering machine from answering the call before the alarm.
- If forced answer is enabled the **[8]** key may be used to force the panel to pick up, “answering the line”.
- If Auto Pickup is enabled it will pick up the line after the number of rings programmed into location 49
- The Call-back feature, when enabled, allows the download software/ to request that the panel call it back using the phone number as programmed into location 50.

**Table 21: Download Options Data;**

LED	Default	Action
<b>1</b>	ON	Fax Defeat
<b>2</b>	ON	Forced Answer
<b>3</b>	ON	Auto Pickup

On = Enable Off = Disable

**LOCATION 49 Number of Rings to Answer (default = 15)**



This location determines the number of rings before the panel “answers” the telephone line. In the event that the panel answers the call and no valid download logon sequence, or DTMF signal, is received within 40 seconds, the panel will terminate the call and hang up the line.

**[INSTALLER CODE] [\*] [4] [9] [\*] [NUMBER OF RINGS TO ANSWER] [\*]**

The valid data range is: 1 - 15.

**Phone Numbers**

**NOTES ON SINGLE REPORTING:**

Single reporting works by dialling the first programmed number within the chosen telephone module. If there is no answer, the second phone number will be dialled. If the second telephone number picks up the call, then the reporting is considered successful.

If the second phone number does not pick up, then it will dial the first number again. It will alternate between the phone numbers, until one is successful, up to the number of dial attempts programmed into location 47.

If a phone number has no value programmed into it, it implies that it is disabled.

**NOTES ON DUAL REPORTING:**

By enabling dual reporting it is possible to select a different format for each reporting medium. In this instance, all data will be transmitted to each phone number (i.e. reported twice) using the format specified for that particular number. Both numbers need to be programmed for dual reporting to work.

If the dual reporting feature is enabled, an event must be communicated to both telephone numbers before the event is considered reported. This feature cannot be used with the join phone numbers option. (See location 46).

If dual reporting is enabled the dual reporting output will be set when the panel dials the second phone number, and cleared when it hangs up at the end of transmission. This output follows the hook relay. It may be used to trigger switching from the telephone line to a radio transmitter.

**NOTES ON HOW TO PROGRAM A PHONE NUMBER:**

Enter numbers consecutively with no other key presses between each digit.

**Inserting pauses**

A pause may be inserted at any point within the telephone number: Entering a value of **[MODE] [3]** will provide a 12-second pause, **[MODE] [4]** will provide an 8-second pause and a value of **[MODE] [5]** will provide a 4-second pause.

To dial a “\*” enter **[MODE] [1]**

To dial a “#” enter **[MODE] [2]**

For a “12-second pause” enter **[MODE] [3]** (On the LCD keypad it will be displayed as a “+”)

For a “8-second pause” enter **[MODE] [4]** (On the LCD keypad it will be displayed as a “=”)

For a “4-second pause” enter **[MODE] [5]** (On the LCD keypad it will be displayed as a “-“)

**[MODE] [0]** will clear the phone number, anything entered into this location after that will NOT be registered.

**EXAMPLE:**

Phone number 1 is to be dialled as follows:

**[0]** followed by a 4-second pause then **[0317051373]**. The key sequences are as follows per **Table 22**.

**Table 22: Phone Number Example**

Data entered	Explanation
[INSTALLER CODE][*]	To enter program mode
[5][1][*]	To enter location 51 (phone number 1)
[0]	To dial the zero
[MODE][5]	This programmes the 4 second pause
[0][3][1]	This enters the area code
[7][0][5][1][3][7][3]	The remainder of the number
[*]	To program the number
[#]	To exit installer menu

Refer to Figure 2 to see how telephone numbers work.

**Figure 2: How Telephone Numbers Work**

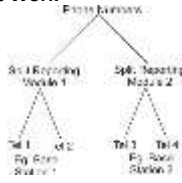

**LOCATION 51 Telephone Number 1**

Program this location to set the primary telephone number. A maximum of 24-digits can be entered. Enter the digits consecutively and after the last digit has been entered, terminate with the [\*] key.

[INSTALLER CODE] [\*] [5] [1] [\*] [TELEPHONE NUMBER 1] [\*]

**LOCATION 52 Telephone Number 2**

Program this location to set the secondary telephone number. A maximum of 24-digits can be entered. Enter the digits consecutively and after the last digit has been entered, terminate with the [\*] key.

[INSTALLER CODE] [\*] [5] [2] [\*] [TELEPHONE NUMBER 2] [\*]

**LOCATION 53 Telephone Number 3**

Program this location to set the third telephone number. A maximum of 24-digits can be entered. Enter the digits consecutively and after the last digit has been entered, end with the [\*] key.

[INSTALLER CODE] [\*] [5] [3] [\*] [TELEPHONE NUMBER 3] [\*]

**LOCATION 54 Telephone Number 4**

Program this location to set the fourth telephone number. A maximum of 24-digits can be entered. Enter the digits consecutively and after the last digit has been entered, end with the [\*] key.

[INSTALLER CODE] [\*] [5] [4] [\*] [TELEPHONE NUMBER 4] [\*]

**LOCATION 55 Serial Reporting Telephone Number**

The telephone number the serially connected reporting device must dial to report any events

[INSTALLER CODE] [\*] [5] [0] [\*] [TELEPHONE NUMBER SERIAL] [\*]

**Note:** Only used if the serial device is able to use this function

**LOCATIONS 61-68 Primary Account Codes (Partitions 1- 8)**

The primary account code is always used for reporting, regardless of whether single or dual reporting is used. This account code is reported to the first telephone number in the telephone module.

Each location represents a partition:

- > Location 61 is partition 1
- > Location 62 is partition 2
- > Location 63 is partition 3
- > Location 64 is partition 4
- > Location 65 is partition 5
- > Location 66 is partition 6
- > Location 67 is partition 7
- > Location 68 is partition 8

[INSTALLER CODE] [\*] [LOCATION] [\*] [PRIMARY ACCOUNT CODE] [\*]

**NB:** If the account code is 0000 no reporting will take place



Refer to Programming Standard Locations to see how to scroll through data in a location using the [\*] key.

**NOTE:** The length of the account code, either 4 or 6 digits, is set in location 24. If the length of the account code is changed from 4 to 6 digits, then the account codes will automatically have 00 at the end of them to make them 6 digits in length.

#### LOCATIONS 71-78 Secondary Account Code (Partitions 1-8)

 The secondary account code is only used when dual reporting is enabled. This account code is reported to the second telephone number in the telephone module.

Each location represents a partition:

- |                              |                              |                              |
|------------------------------|------------------------------|------------------------------|
| ➤ Location 71 is partition 1 | ➤ Location 72 is partition 2 | ➤ Location 73 is partition 3 |
| ➤ Location 74 is partition 4 | ➤ Location 75 is partition 5 | ➤ Location 76 is partition 6 |
| ➤ Location 77 is partition 7 | ➤ Location 78 is partition 8 |                              |

[INSTALLER CODE] [\*] [LOCATION] [\*] [SECONDARY ACCOUNT CODE] [\*]

**NB:** If the account code is 0000 no reporting will take place

**NOTE:** The length of the account code, either 4 or 6 digits, is set in location 24. If the length of the account code is changed from 4 to 6 digits, then the account codes will automatically have 00 at the end of them to make them 6 digits in length. Refer to section 0 Programming Standard Locations to see how to scroll through data in a location using the [\*] key.

### Zone Properties

#### LOCATIONS 101-164 Zone Type Properties (Zones 1 – 64)

 Locations 101-164 are used to configure properties for zones 1-64 respectively. Each location contains a bitmap of 5 zone type properties, as per Table 23.

#### Tamper by Zone

Individual zones may be enabled for tamper by zone so if the panel is unarmed and a tamper condition occurs, the siren will not activate but a tamper condition will be reported. If the panel is armed and a tamper condition occurs on the particular zone, an audible alarm condition will register and a tamper condition will be reported.

#### Cross-zoning

This feature is useful for reducing false alarms. Violating zones with the cross-zone property enabled will not immediately generate an alarm. The Cross-zone Delay Time is started as per location 12.

Depending on the value programmed into location 13 (Cross-zone Trip Count), the zone (or any other zone with cross-zone option enabled) must trip the number of times programmed into location 13 before an alarm is generated. An alarm will also be generated should any single zone remain violated for the entire delay period (location 12). An Entry/Exit cannot be configured as a cross-zone. Each cross-zone will have its own timer.

#### Shutdown Zone

While armed, if the number of alarm violations generated by a swinger zone equals the shutdown count (location 10), the Alarm Panel no longer reports violations of that swinger zone. The swinger shutdown counter will reset when the system is disarmed and re-armed, it can be programmed to try and re-enable the zone automatically when the 24 hour self-test report is generated. Each zone has its own shutdown count programmable from 1 to 15.

#### Silent Zone

This property allows any zone that would ordinarily activate the siren to be programmed as a Silent zone i.e. the violation of a Silent zone, while the system is armed, will not activate the siren. However, the relevant reporting code (if programmed) will still be reported. All zones can be programmed as a Silent zone, except for the Fire zone.

#### Chime Zone

The chime mode allows the user to monitor nominated zones while the system is disarmed. The keypad buzzer will sound five times when the nominated zone is violated - the siren will NOT sound and no alarm condition will be reported. Peripherals sending zone updates to the panel will not cause chimes on a zone unless the zone is restored and then violated.

## Zone Bypassing

This option allows a zone to be disabled or if it is covering a sensitive area not to be disabled.

## Stay Profile

Stay zones are zones that are bypassed automatically when the system is "STAY ARMED". To avoid triggering the alarm, zones such as bedrooms that are protected by Passive Infra-Red (PIR) detectors or windows that may be opened, must be bypassed when "staying at home".

Stay zones need only be programmed once. Each time the system is armed in the Stay Mode the pre-selected stay zones will be bypassed automatically. The panel allows for 4 unique STAY PROFILES to be stored, consisting of a pre-selected combination of STAY and BUZZ zones, to suit a specific STAY ARM requirement. STAY and BUZZ zones can be programmed for each profile only once the particular profile has been selected.

## Buzz Profile

Violation of a Buzz zone when Stay Armed will cause the keypad buzzer to sound for a period of 30 seconds during which time a valid user code must be entered. If a valid user code is not entered during this period, the system will register an alarm condition. This feature helps prevent unnecessary false alarms.

If an Entry/Exit zone is programmed as a Buzz zone, violation of the Entry/Exit zone (when the panel is Stay Armed) will cause the keypad buzzer to sound for the duration of the entry delay time (in place of the default 30 seconds). This, if the panel is Stay Armed, allows the user to enter the premises and disarm the panel. If it is not programmed as a Buzz zone, the alarm will be triggered immediately. If the panel was stay armed, a violation of the Entry/Exit zone will always start the Entry/Exit delay Any Entry/Exit zone programmed as a Buzz zone will not buzz.

**Table 23: Zone Type Properties Data**

LED	Default	Zone Properties
1	OFF	Tamper by Zone
2	OFF	Cross-zone
3	OFF	Shutdown Zone
4	OFF	Silent Zone
5	OFF	Chime Zone
6	ON	Zone bypassing
7	OFF	Reserved
8	OFF	Reserved

LED	Default	Zone Properties
9	OFF	Stay Profile 1
10	OFF	Stay Profile 2
11	OFF	Stay Profile 3
12	OFF	Stay Profile 4
13	OFF	Buzz Profile 1
14	OFF	Buzz Profile 2
15	OFF	Buzz Profile 3
16	OFF	Buzz Profile 4

On = Enable Off = Disable

### NOTE:

Please see section 14 of the User manual for more information on how to select stay profiles and how to switch between them.

## No Movement – Advanced

### LOCATION 165 No Movement Auto Arm Time Out (default =0000)

If no violations are registered for the period of time specified in this location then the alarm will auto arm. This may be used if you forget to arm when leaving for work; the alarm will then automatically away arm itself if no violations were registered.

This function is only available if values have been programmed into locations 166 and 167.

This No Movement Auto Arm event reports a close event, using user number 133, but only if CID or SIA reporting has been selected.

 Enter a 2-digit duration in hours for each of the 8 partitions and program as a 16-digit string, followed by the [\*] key.

 [INSTALLER CODE] [\*] [1] [6] [5] [\*] [PARTITION NO.] [\*] [HHMM] [\*]

The valid data range is: 00h00m to 23h59m.

Partition no. is: 1-8.

Refer to Using Sub-locations to see how to scroll from one sub-location to another using the [\*] key.

**NOTE:** If this location is disabled, then by default, locations 166 and 167 will also be disabled.

#### LOCATION 166 No Movement Auto Arm Start (default = 0000)

Program the start time to start checking for no movement. For example, if you leave your premises at 06:50 am, program the start time to be 07:00.

 Enter a 4-digit time [HHMM] for each of the 8 partitions and program as a 32-digit string, followed by the [\*] key.



[INSTALLER CODE] [\*] [1] [6] [6] [\*] [PARTITION NO.] [\*] [HHMM] [\*]

The valid data range: 00h00m – 23h59m.

Partition no. is: 1-8.

Refer to Using Sub-locations to see how to scroll from one sub-location to another using the [\*] key.

#### LOCATION 167 No Movement Auto Arm End (default = 0100)

Program the end time to stop checking for no movement. For example, using 07:00 programmed into location 166 and if 2 hours is needed, then program 09:00.

 Enter a 4-digit time [HHMM] for each of the 8 partitions and program as a 32-digit string, followed by the [\*] key.



[INSTALLER CODE] [\*] [1] [6] [7] [\*] [PARTITION NO.] [\*] [HHMM] [\*]

The valid data range: 00h00m – 23h59m.

Partition no. is: 1-8.

Refer to Using Sub-locations to see how to scroll from one sub-location to another using the [\*] key.

#### LOCATION 168 No Movement Medical Alarm Time Out (default = 0000)

If no movement is detected, while the panel is disarmed, for the period of time specified in this location then the alarm will activate.

This function is only available if values have been programmed into locations 169 and 170.

This No Movement Medical Alarm event reports a medical event, (see location 339 if custom reporting codes have been used).

##### EXAMPLE:

This may be used to monitor for elderly people who have suddenly become incapacitated and are unable to sound the panic.

 Enter a 2-digit duration in hours for each of the 8 partitions and program as a 16-digit string, followed by the [\*] key.



[INSTALLER CODE] [\*] [1] [6] [9] [\*] [PARTITION NO.] [\*] [HHMM] [\*]

The valid data range is: 00h00m to 23h59m.

Partition no. is: 1-8.

Refer to Using Sub-locations to see how to scroll from one sub-location to another using the [\*] key.

**NOTE:** If this location is disabled, then by default, locations 169 and 170 will also be disabled. This means that even if you put values into locations 169 and 170, no movement medical alarm will not commence.

#### LOCATION 169 No Movement Medical Alarm Start (default = 0000)

The start time can be set for when you know that the person will be awake and active.

Program the start time to start checking for movement. For example, you expect a person to be awake at 6 am, program the start time to be 06:00.

 Enter 4-digit time [HHMM] for each of the 8 partitions and program as a 32-digit string, followed by the [\*] key.



[INSTALLER CODE] [\*] [1] [6] [9] [\*] [PARTITION NO.] [\*] [HHMM] [\*]

The valid data range: 00h00m – 23h59m.

Partition no. is: 1-8.

Refer to Using Sub-locations to see how to scroll from one sub-location to another using the [\*] key.

**LOCATION 170 No Movement Medical Alarm End (default = 0100)**

Program the end time to stop checking for movement. For example, using 06:00 programmed into location 169 and if 2 hours is needed, then program 08:00.

 Enter a 4-digit time [HHMM] for each of the 8 partitions and program as a 32-digit string, followed by the [\*] key.

 [INSTALLER CODE] [\*] [1] [7] [0] [\*] [PARTITION NO.] [\*] [HHMM] [\*]

The valid data range: 00h00m – 23h59m.

Partition no. is: 1-8.

Refer to Using Sub-locations to see how to scroll from one sub-location to another using the [\*] key.

**LOCATION 171 to 178 No Movement Auto Arm/Medical Alarm Days**

Choose which days of the week that you want the, arm on no movement or medical alarm to be enabled.

LED	ARM Days of the Week
1	Monday
2	Tuesday
3	Wednesday
4	Thursday
5	Friday
6	Saturday
7	Sunday
All OFF	(Arm Day Disabled)

LED	Medical Days of the Week
9	Monday
10	Tuesday
11	Wednesday
12	Thursday
13	Friday
14	Saturday
15	Sunday
All OFF	(Disarm Day Disabled)

**LOCATION 180 Auto Arm Time (default = 2400)**

This location sets the time at which a particular partition will auto arm. To disable this location, enter 2400 as the time.

**EXAMPLE:**

To auto arm at 11:35 pm, enter 2335. All four digits must be entered, including any leading zeros (0100 = 1 am).

 Enter a 4-digit time for each of the 8 partitions and program as a 32-digit string, followed by the [\*] key.

 [INSTALLER CODE] [\*] [1] [8] [0] [\*] [PARTITION NO.] [\*] [HHMM] [\*]

The valid data range is: 00h00m – 23h59m, with 24h00m to disable. Partition no. is: 1-8.

Refer to Using Sub-locations to see how to scroll from one sub-location to another using the [\*] key.

**LOCATIONS 181 - 188 Auto Arm/Disarm Days (default = all OFF)**

 These bitmapped locations set the days on which the selected partition will auto arm and disarm at the times programmed in locations 180 and 189 respectively. Refer to Table 24 for the values

Each location represents a partition:

- Location 181 is partition 1      ➤ Location 182 is partition 2      ➤ Location 383 is partition 3
- Location 184 is partition 4      ➤ Location 185 is partition 5      ➤ Location 186 is partition 6
- Location 187 is partition 7      ➤ Location 188 is partition 8      ➤

**Table 24: Arm/ Disarm Days Data**

LED	ARM Days of the Week
1	Monday
2	Tuesday
3	Wednesday
4	Thursday
5	Friday
6	Saturday
7	Sunday
All OFF	(Arm Day Disabled)

LED	DISARM Days of the Week
9	Monday
10	Tuesday
11	Wednesday
12	Thursday
13	Friday
14	Saturday
15	Sunday
All OFF	(Disarm Day Disabled)

Select the days to ARM (LEDs 1-7) and DISARM (LEDs 9-15) by toggling them on/off.

### LOCATION 189 Auto Disarm Time (default = 2400)

This location sets the time at which a particular partition will auto disarm. To disable, enter 2400.

#### EXAMPLE:

To auto disarm at 06:00 am, enter 0600. All four digits must be entered, including any leading zeros (0100 for 1 am).

 Enter a 4-digit time for each of the 8 partitions and program as a 32-digit string, followed by the [\*] key.



[INSTALLER CODE] [\*] [1] [8] [9] [\*] [PARTITION NO.] [\*] [HHMM] [\*]

The valid data range is: 00h00m – 23h59m, with 24h00m to disable.

Partition no. is: 1-8.

Refer to Using Sub-locations to see how to scroll from one sub-location to another using the [\*] key.

**NOTE:** For this auto disarm to be active; partition option 15 must be enabled in locations 221-228 and the appropriate disarm days) selected in locations 181-188.

### LOCATION 190 Auto Arm Delay (default = 0200 i.e. 2 minutes)

This location sets the delay period for the keypad buzzer warning, which is initiated before the panel auto arms. At the completion of the Auto Arm Delay, the panel will arm. A valid user code entered during the delay period will cancel the auto arming.



Enter a 4-digit time for each of the 8 partitions and program as a 32-digit string, followed by the [\*] key.



[INSTALLER CODE] [\*] [1] [9] [0] [\*] [PARTITION NO.] [\*] [MMSS] [\*]

The valid data range is: 00m01s – 59m59s.

Partition no. is: 1-8.

Refer to Using Sub-locations to see how to scroll from one sub-location to another using the [\*] key.

## Security Codes

### LOCATION 197 Installer Code (default = 9999)



This location is used to change the installer code to a code that is more preferable.

[INSTALLER CODE] [\*] [1] [9] [7] [\*] [NEW INSTALLER CODE] [\*]

Refer to Programming Standard Locations to see how to scroll through data in a location using the [\*] key.

**NOTE:** Refer to location 23 to set the number of digits in the installer code.

### LOCATION 198 Download Code (default = 9999)



This location is used to change the download code to a code that is more preferable.

The download code (in conjunction with the installer code) is required for download access to the Alarm Panel. A value of [10] programmed into location 34 will prevent the download code from being defaulted when performing a hardware default.

[INSTALLER CODE] [\*] [1] [9] [8] [\*] [NEW DOWNLOAD CODE] [\*]

**NOTE:** If the panel is defaulted, the download code will revert to 9999. The download code is 4-digits in length.

### LOCATION 199 Maintenance Code (default = 8888)



Users can be given limited access to installer mode by entering the maintenance code programmed in this location.

Panel functions that can be edited in maintenance mode are:

- |                             |                                  |
|-----------------------------|----------------------------------|
| ➤ Siren time                | ➤ Siren Delay                    |
| ➤ Keypad lockout counr      | ➤ Keypad Sleep delay             |
| ➤ Daylight savings settings | ➤ Partition auto arm settings    |
| ➤ No zone activity auto arm | ➤ No zone activity alarm settins |

[INSTALLER CODE] [\*] [1] [9] [9] [\*] [NEW MAINTENANCE CODE] [\*]

**NOTE:** Refer to location 23 to set the number of digits in the maintenance code.

## Partition Options

### LOCATIONS 201 – 208 Partition Zone Allocation

 Program these locations to allocate zones to each of the 8 partitions. Lit zone number LEDs represent the zones allocated to the selected partition. The zones are displayed as 4 pages of 16 zones each as per Table 25. To scroll to the next page of 16 zones, press the [\*] key.

Zones are common, which means that one zone can be allocated to more than one partition.

The keypad start zone in location 241 needs to be programmed for keypads displaying zone numbers higher than 16.

Each location represents a partition number:

- Location 201 is partition 1      ➤ Location 202 is partition 2      ➤ Location 203 is partition 3
- Location 204 is partition 4      ➤ Location 205 is partition 5      ➤ Location 206 is partition 6
- Location 207 is partition 7      ➤ Location 208 is partition 8      ➤

Figure 3 and Figure 4 show the order in which the LEDs display to show you which zones you are viewing as per Table 25.

**Figure 3: Paging Indication on the Classic Keypad**

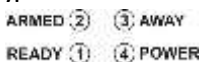

**Figure 4: Paging Indication on the Curved Keypad**

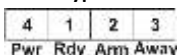

**Table 25: Zones per Partition Page**

Page	1				2				3				4			
LED	READY				ARM				AWAY				POWER			
Zones	1	9			17	25			33	41			49	57		
	2	10			18	26			34	42			50	58		
	3	11			19	27			35	43			51	59		
	4	12			20	28			36	44			52	60		
	5	13			21	29			37	45			53	61		
	6	14			22	30			38	46			54	62		
	7	15			23	31			39	47			55	63		
	8	16			24	32			40	48			56	64		

### LOCATIONS 211 – 218 Partition Arm Options (Partitions 1 – 8)

 These locations are used to configure arm options for each partition. Refer to Table 26 for the values that can be selected.

Each location represents a partition:

- Location 211 is partition 1      ➤ Location 212 is partition 2      ➤ Location 213 is partition 3
- Location 214 is partition 4      ➤ Location 215 is partition 5      ➤ Location 216 is partition 6
- Location 217 is partition 7      ➤ Location 218 is partition 8      ➤

**Quick Arm:**

This option allows the user to arm the panel by holding down the [1] key for three seconds. The keypad will beep once to indicate that the arm sequence has begun.

**Force Arm:**

With this option enabled, the panel will arm with violated zones e.g. an open window. This forces any violated zones to be temporarily bypassed when the panel arms. If such bypassed zones restore during the arm cycle (the window is closed, for example), the zone is automatically re-activated (un-bypassed) and a subsequent violation will trigger an alarm.

**Siren Toot on Away Arm / Disarm:**

This option allows the user an audible confirmation that arming or disarming of the panel has occurred. The siren is programmed to give a short beep after successful arming, and two short beeps after disarming. This is useful when used in conjunction with remote or key-switch arming/disarming.

### Engineer Reset:

Enabling this option will prevent the panel from being rearmed after an alarm condition has occurred. In order to re-arm the panel, the installer will be required to enter a valid installer code.

If option 7 is set in location 16, an engineer reset trouble condition will also be displayed on the keypad.

**Table 26: Partition Arm Options Data**

LED	Default	Action
1	OFF	Instant Arm
2	ON	Instant Key-switch Arm
3	ON	Quick Away Arm Key
4	ON	Quick Stay Arm Key
5	ON	Auto Stay Arm if No Exit Zone is Triggered*
6	OFF	Auto Stay Arm if No Exit Zone is Triggered When Arming with a Key-switch *
7	OFF	Forced Arm
8	ON	Zone Bypassing
9	OFF	Arm with Zones in the Entry Route Violated
10	OFF	Siren Toot on Arm
11	OFF	Siren Toot on Disarm
12	ON	Entry Beep
13	ON	Exit Beep
14	OFF	Engineer's Reset
15	OFF	Auto Disarm
16	OFF	Opening/Closing User Reporting

On = Enable Off = Disable

### LOCATIONS 221 – 228 Extra Partition Options (Partitions 1 - 8)

 These locations are used to configure extended options for each partition. Refer to Table 27 for the values that can be selected.

Each location represents a partition:

- Location 221 is partition 1    ➤ Location 222 is partition 2    ➤ Location 223 is partition 3
- Location 224 is partition 4    ➤ Location 225 is partition 5    ➤ Location 226 is partition 6
- Location 227 is partition 7    ➤ Location 228 is partition 8    ➤

**Table 27: Extended Partition Options Data**

LED	Default	Action
1	OFF	Disable Automatic Re-enabling of Shutdown Zones at the Time of the Dialler test
2	OFF	Disable Bypassing of Common Zones
3	OFF	Disable Delay Before Communications
4	OFF	Disable Keypad Lockout
5	OFF	Disable Silent Keypad Panic
6	OFF	Disable Toot on Successful Communication
7	OFF	Enable Stay arm Reporting
8	OFF	Send Zone Restoral Immediately

On = Enable Off = Disable

## Delays

### LOCATION 230 Exit Delay Period (default = 0030)

The exit delay period is the amount of time between arming the panel and successfully exiting the premises without violating Entry/Exit and Follower zones.

The exit delay will begin after the system is armed by either:

- Entering a valid user code
- Pressing the [1] key and holding it down until the system is armed
- Pressing the [6] key and holding it down until the system is armed

 Enter a 4-digit exit delay period for each of the 8 partitions and program as a 32-digit string, followed by the [\*] key.

 **[INSTALLER CODE] [\*] [2] [3] [0] [\*] [PARTITION NO.] [\*] [MMSS] [\*]**

The valid data range is: 00m00s – 59m59s.

Partition no. is: 1-8.

Refer to Using Sub-locations to see how to scroll from one sub-location to another using the [\*] key.

### LOCATION 231 Primary Entry Delay Period (default = 0030)

The primary entry delay begins after the violation of a Primary Entry/Exit zone. During this delay, it is permissible to violate Follower zones without causing an alarm condition.

If a Follower zone is violated without a prior Entry/Exit zone violation, it will be treated as an Instant zone. If an Instant zone is violated during this period, an alarm condition will immediately be registered.

 Enter a 4-digit entry delay period for each of the 8 partitions and program as a 32-digit string, followed by the [\*] key.

 **[INSTALLER CODE] [\*] [2] [3] [1] [\*] [PARTITION NO.] [\*] [MMSS] [\*]**

The valid data range is: 00m00s – 59m59s.

Partition no. is: 1-8.

Refer to Using Sub-locations to see how to scroll from one sub-location to another using the [\*] key.

### LOCATION 232 Secondary Entry Delay Period (default = 0030)

The secondary entry delay begins after the violation of a Secondary Entry/Exit zone. During this delay, it is permissible to violate Follower zones without causing an alarm condition.

 Enter a 4-digit entry delay period for each of the 8 partitions and program as a 32-digit string, followed by the [\*] key.

 **[INSTALLER CODE] [\*] [2] [3] [2] [\*] [PARTITION NO.] [\*] [MMSS] [\*]**

The valid data range is: 00m00s – 59m59s.

Partition no. is: 1-8.

Refer to Using Sub-locations to see how to scroll from one sub-location to another using the [\*] key.

## Options to Configure Keypads

### LOCATION 240 Keypad Partition (default = Partition 1)

Program this location to allocate each keypad to a partition. Enter the partition number to which each keypad, with an ID 1-8, must be allocated. To view the ID of a keypad refer to location 243.

 Enter 1 digit for each of the 8 keypads and program as an 8-digit string, followed by the [\*] key.

 **[INSTALLER CODE] [\*] [2] [4] [0] [\*] [KEYPAD NO.] [\*] [PARTITION NO.] [\*]**

The valid data range is: 1 – 8.

Partition no. is: 1-8.

Refer to Using Sub-locations to see how to scroll from one sub-location to another using the [\*] key.



### LOCATION 241 Keypad Display Start Zone (default = Zone 1)

The zones which a particular LED keypad displays is determined by programming the keypad start zone location. The number programmed into this location is the zone which will be assigned to LED 1 on the keypad. The keypad will display subsequent zones in order. The keypad will only display zones belonging to its partition.



Enter a 2-digit display start zone (01 – 64) for each of the 8 keypads and program as a 16-digit string, followed by the [\*] key.



[INSTALLER CODE] [\*] [2] [4] [1] [\*] [KEYPAD NO.] [\*] [START ZONE] [\*]

The valid data range is: 01 – 64.

Refer to Using Sub-locations to see how to scroll from one sub-location to another using the [\*] key.

**NOTE:** This only applies to LED keypads and not LCD keypads.

### LOCATION 242 Keypad Zone Number (default = 0 i.e. Disabled)

A keypad zone must be allocated to any zone number (1 – 64), before it can be used. The corresponding zone type must be programmed in locations 1 – 8 and the properties configured in locations 101 – 164. If you configure a keypad to a zone number that is already a wired zone, then the keypad will take priority on the zone number.



Enter a 2-digit zone number (01 – 64) for each of the 8 keypads and program as a 16-digit string, followed by the [\*] key.



[INSTALLER CODE] [\*] [2] [4] [2] [\*] [KEYPAD NO.] [\*] [ZONE NO.] [\*]

The valid data range is: 01 – 64.

Refer to Using Sub-locations to see how to scroll from one sub-location to another using the [\*] key.

### LOCATION 243 View Keypad ID



View the data in this location to determine the Keypad ID (1 – 8).

[INSTALLER CODE] [\*] [2] [4] [3] [\*]

**NOTE:** This is a read-only location and no data can be changed.

### LOCATIONS 251 - 258 Keypad Options



These locations are used to configure options for a keypad. Refer to Table 28 for the available options.

Each location represents a keypad:

- Location 251 is keypad 1
- Location 252 is keypad 2
- Location 253 is keypad 3
- Location 254 is keypad 4
- Location 255 is keypad 5
- Location 256 is keypad 6
- Location 257 is keypad 7
- Location 258 is keypad 8

**Table 28: Keypad Options Data**

LED	Default	Action
1	ON	The keypad will timeout back to its default partition after it has been used to view another partition
2	OFF	Keypad sleep mode disabled
3	OFF	Global Keypad Status
4	OFF	Display all of Zones from all Partitions
5	OFF	Shows all Partitions on key press 1,5 & 6
6	OFF	Stay Profile Menu

On = Enable Off = Disable

- LED 3 must be ON in order for LED 1 to have any effect.
- The Global Keypad Status will allow sixteen zones to be displayed regardless of the partition to which either the keypad or zones are assigned.  
On a LED keypad from the keypad start zone number plus 16 zones.  
On a LCD keypad from the keypad start zone number up to 64 zones.

**Figure 5: IDS/Duevi Wireless PCB:**

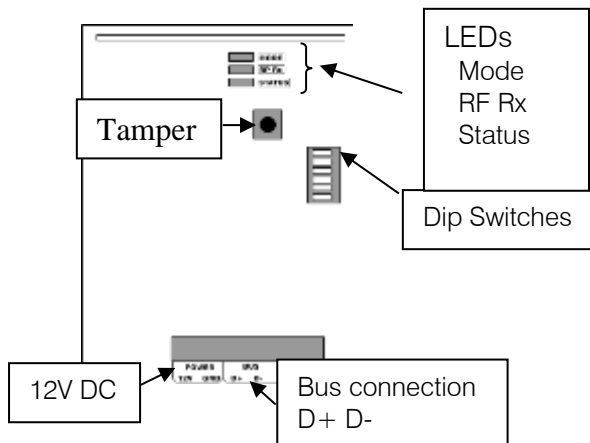

### DIP switch operation

To address the expander, set the Dipswitches as per table below. Depending on what address is used on the zone expander, the starting zone number of the expander will be as per table below.

**Note:** Wireless zones take president over wired zones, if you learn a detector replacing a wired zone; the wired zone will be ignored. If a detector is allocated to a zone, and the expander corresponding to that zone as addressed in the table below is not installed, the panel will not communicate with that detector.

**Table 29: Dipswitch Configuration Wireless expander**

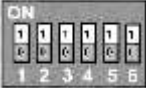
Binary value on switch	Expander's zones
	
Dipswitch 1 up	Zone 1 -16
Dipswitch 2 up	Zone 17 – 32 (X64 only)
Dipswitches 1 + 2 up	Zone 33 – 48 (X64 only)
Dipswitch 3 up	Zone 49 – 64 (X64 only)
Dipswitch 4	Not used
Dipswitch 5 off (down)	PGM1 will mimic PGM1 output on bus wired expander with the same ID
Dipswitch 5 up	PGM1 will set on RF Jam, and clear on RF Jam clear for the zones allocated to the receiver
Dipswitch 6 off (down)	PGM2 will mimic PGM2 output on bus wired expander with the same ID
Dipswitch 6 up	PGM2 will set on ANY Supervision fail, and clear on ALL supervisions restored for the zones allocated to the receiver

Note: Only X64 supports receiver ID 2 to ID 4.

Example:

Zones 1 to 16 have wired zones already installed on them. Now you wish to add another 16 wireless zones to the system, by making the receiver's ID 2, all zone on the wireless receiver will be automatically add to zones 17 to 32.

### Defaulting

The second operation is a standalone default feature. If all Dip-switches are ON during power-up then the unit will default. Please power down after, set appropriate address and power up to resume normal operation.

## LED operation

There are 3 LEDs on the board marked "MODE", "RF RX" and "STATUS".

**STATUS:** LED that will indicate whether it is connected to the X-series panel properly. If the receiver notices X-series panel communications then it will stay ON.

**RF RX:** LED that will indicate when the receiver received a message from a learnt detector.

**MODE:** LED that indicates current operating errors. Errors are indicated much the same as the wired expander. If the LED is ON continuously then there are no errors. However if there are errors it will start pulsing the error number. These error pulses will be separated by a 1sec pause with the LED OFF.

Pulse error number:

1. Duevi Receiver Not Responding
2. No activity on the X-series Serial bus
3. No X-series panel messages detected
4. No messages for this peripheral detected from X-series panel
5. Not used
6. Expander not yet registered on the X-series panel
7. Expander tamper violated
8. Unsupported DIP address configured

## LOCATION 260 Wireless Functions

This location is broken up into different sub locations. Each sub location has a different function.

Sub location 1 learning wireless devices

Sub location 2 deleting wireless devices

Sub location 3 checking signal strength.

Sub location 4 Supervision Time.

### ➤ Sub Location 1: Adding Wireless Detectors

There are two methods of teaching a wireless device to the wireless receiver.

1. Pressing the tamper switch when required. Note: This step can be done with all types of keypads
2. Typing in the serial number of the device when required. Note: This step can only be done with a LCD keypad.

## LCD Keypad instructions

Upon Sub menu entry the user will notice the following:

```
Zone Names <*>
Zone No + *
```

The user now needs to specify which zone they want to add to the receiver by either:

- Pressing [ < ], [ > ] and scrolling through the zone names and then press [ \* ] to select the zone.
- Enter the zone number then [ \* ] and to select it press [ \* ] again.
- [ # ] will return user to sub menu selection entry.

Note: When scrolling through the zones the user may be presented with one of the following:

```
Zone Names <*>
02 Zone 02 W
```

```
Zone Names <*>
02 Main Loung W
```

Presence of the "W" after the zone name will signify whether the zone has been pre-allocated to a wireless detector.

Selecting a zone that has been pre-allocated will result in an error and the user will be alerted with 3 error beeps.

Upon selecting a valid unallocated zone the user will be presented with the following.

Tamper or Enter  
SN:-----

The user must now either trigger the tamper on the detector or type in the serial number of the device, which is on the product label on the device.

When the user triggers the tamper the system will receive a notification and determine whether the detector has already been assigned to any other zones. If this is the case the user will be notified by 3 error beeps and the menu will keep waiting for a tamper from an unassigned detector.

Incorrect or pre-allocated serial numbers will also result in a 3 beep error tone and the menu will keep waiting for a valid entry.

Upon a valid serial number being entered or set via tampering the device the user will be presented with the following.

Duevi  
SN: 12345678 [\*]

- The user needs to confirm the detector adding by pressing [\*].  
The system will then assign the detector and return to zone selection menu.

### LED Keypad Instructions

An LED keypad can only display 16 zones, therefore to see the all 64 zones a user must page through each set of 16 zones by pressing the [\*] key.

Below is a diagram showing each page and how to distinguish which zones are being displayed. The status LEDs, Pwr, Rdy, Arm and Away indicate which zones are being displayed.



Note: Any zone LEDs that are on, are zones already allocated to a wireless device.

To learn a wireless device using an LED keypad:

- Choose a zone that is not on by typing in the zone number followed by [\*].  
The zone LED will begin to flash indicating that it is ready to receive the devices information once tampered.
- Tamper the device and if correct the LED will stop flashing and remain on, indicating the zone is learnt.

#### ➤ **Sub Location 2:                  Deleting Wireless Detectors**

This sub location is accessed the same as sub location 1.

#### ➤ **Sub Location 3:                  Signal Strength of Detector**

This sub location is accessed the same as sub location 1 and 2.

Note: Only the device learnt to that zone may be tested.

#### ➤ **Sub Location 4:                  Supervision Setup**

The user needs to enter one of the following numbers to instruct their receivers globally of their new supervision time parameter:

[1][\*][\*] - 3 hours before supervision fail.

[2][\*][\*] - 24 hours before supervision fail.

**Default 24 hours**

**Note:** The supervision period on your detector must be set to match the selected supervision period on the panel

## Reporting Codes - Advanced

This section describes how to configure custom reporting codes if the format of said reporting code is not Contact ID or SIA.

### LOCATION 261 to 264 Stay Zone Reporting Codes

Locations to enter reporting codes if you want to report stay zones to the control room. This is for formats other than Contact ID and SIA. Default is 00.

## Global Reporting Codes

### LOCATION 300 Global Reporting Code 1

This location is used to configure global reporting codes to be used in the event that neither Contact ID nor SIA formats are used. These codes will be used for any of the other formats selected in Communications Setup - Advanced have been selected.

- **Sub-location 1 is AC Fail**  
The Alarm Panel will transmit this code in the event of an AC failure but only after the AC failure delay time has elapsed (location 15). Option 1 in Table 41 needs to be enabled.
- **Sub-location 2 is AC Restore**  
The Alarm Panel will transmit this code once the AC restore delay time has elapsed (location 15). It will however only be reported if an AC failure was registered. Option 4 in Table 42 needs to be enabled.
- **Sub-location 3 is Communication Failed**  
This code is reported when the alarm has tried to communicate with the alarm reaction company unsuccessfully after trying the number of times programmed in location 47.
- **Sub-location 4 is Communication Restored**  
This code is reported when the alarm has communicated with the alarm reaction company successfully after logging a communication fail.
- **Sub-location 5 is Communication Line Tamper**  
If telephone line monitoring is enabled (location 14), this code is reported if there is a tamper on the telephone line. Option 3 in Table 41 needs to be enabled.
- **Sub-location 6 is Communication Line Restored**  
If telephone line monitoring is enabled (location 14), this code is reported once the telephone line integrity has been restored. Option 6 in Table 42 needs to be enabled.
- **Sub-location 7 is Siren Monitor Fail**  
This code is reported when the siren fuse blows or when the siren or siren wiring is tampered with. Option 4 in Table 41 needs to be enabled.
- **Sub-location 8 is Siren Monitor Restored**  
This code is reported when the siren fuse is replaced or when the siren or siren wiring has been restored to working order.



Enter a 2-digit reporting code for each of the 8 sub-locations and program as a 16-digit string, followed by the [\*] key.



**[INSTALLER CODE] [\*] [3] [0] [0] [\*] [SUB-LOCATION] [\*] [REPORTING CODE] [\*]**

The valid data range is: 01-FF, with 00 to disable.

If any of the sub-locations are disabled here, then the reporting codes will not report – even if they are enabled

Refer to Using Sub-locations to see how scroll through sub-location using the [\*] key.

**NOTE:** The values are hexadecimal. Refer to Table 3 on how to program hexadecimal values.

## LOCATION 301 Global Reporting Code 2

This location is used to configure global reporting codes to be used in the event that Neither Contact ID or SIA formats are used. These codes will be used when any of the other formats in Communications Setup - Advanced have been selected.

- **Sub-location 1 is Battery Low**  
A low battery condition is reported when the battery voltage drops below 11V for a period longer than 5 minutes or immediately if it drops below 10V. Option 5 in Table 41 needs to be enabled..
- **Sub-location 2 is Battery Restored**  
This code is reported once the battery voltage rises above 12V for a period of five minutes. Option 8 in Table 42 needs to be enabled.
- **Sub-location 3 is Aux 12V Fuse Failed**  
This code is reported when there is a problem with the Aux 12V. Option 6 in Table 41 needs to be enabled.
- **Sub-location 4 is Aux 12V Fuse Restored**  
This code is reported when the Aux 12V fuse has been replaced.
- **Sub-location 5 is Installer reset required**  
This code is reported when enabled in location 211 – 218 and the alarm is triggered.
- **Sub-location 6 is Installer reset Restored**  
This code is reported when Installer reset is enabled in location 211 – 218 and the alarm is triggered and the installer code has been entered to enable the system to be armed.
- **Sub-location 7 is Box Tamper**  
This code is reported when the box tamper contacts are open for a period exceeding 200 ms. Option 8 in Table 41 needs to be enabled.
- **Sub-location 8 is Box Tamper Restored**  
This code is reported once the box tamper is closed.



Enter a 2-digit reporting code for each of the 8 sub-locations and program as a 16-digit string, followed by the [\*] key.

**NOTE:** When programming using the string method, reserved sub-locations will still need data to be inputted into them to maintain the 16-digits needed to successfully program. Inputting data into a reserved sub-location will not affect the value of the sub-location. Reserved sub-locations have a value of 00.



[INSTALLER CODE] [\*] [3] [0] [1] [\*] [SUB-LOCATION] [\*] [REPORTING CODE] [\*]

The valid data range is: 01-FF, with 00 to disable.

If any of the sub-locations are disabled here, then the reporting codes will not report – even if they are enabled  
Refer to Using Sub-locations to see how to scroll through sub-location using the [\*] key.

**NOTE:** The values are hexadecimal. Refer to Table 3 on how to program hexadecimal values.

## LOCATION 302 Global Reporting Code 3

This location is used to configure global reporting codes to be used in the event that Neither Contact ID or SIA formats are used. These codes will be used when any of the other formats in Communications Setup - Advanced have been selected.

- **Sub-location 1 is Bus Device Tamper**  
This code is reported when there is a tamper condition on any external device attached to the keypad bus. Option 1 in Table 42 needs to be enabled.
- **Sub-location 2 is Bus Device Tamper Restored**  
This code is reported when the tamper condition on any external device attached to the keypad bus is corrected.
- **Sub-location 3 is Bus Peripheral Communication Fail**  
This code is reported when any external device attached to the keypad bus goes missing. Option 2 in Table 42 needs to be enabled..
- **Sub-location 4 is Bus Peripheral Communication Restored**  
This code is reported when any external device attached to the keypad bus is restored.

- **Sub-location 5 is Bus Peripheral Power/Battery Low**  
This code is reported when a peripheral, on the bus, experiences a low power supply.
- **Sub-location 6 is Bus Peripheral Power/Battery Restored**  
This code is reported when a peripheral, on the bus, power supply is restored.
- **Sub-location 7 is Wireless Detector Battery Low**  
This code is reported when a wireless detector, experiences a low battery.
- **Sub-location 8 is Wireless Detector Battery Restored**  
This code is reported when a wireless detector's battery is replaced after a low battery is reported.

 Enter a 2-digit reporting code for each of the 8 sub-locations and program as a 16-digit string, followed by the [\*] key.

**NOTE:** When programming using the string method, reserved sub-locations will still need data to be inputted into them to maintain the 16-digits needed to successfully program. Inputting data into a reserved sub-location will not affect the value of the sub-location. Reserved sub-locations have a value of 00.



**[INSTALLER CODE] [\*] [3] [0] [3] [\*] [SUB-LOCATION] [\*] [REPORTING CODE] [\*]**

The valid data range is: 01-FF, with 00 to disable.

If any of the sub-locations are disabled here, then the reporting codes will not report – even if they are enabled. Refer to Using Sub-locations to see how to scroll through sub-location using the [\*] key.

**NOTE:** The values are hexadecimal. Refer to Table 3 on how to program hexadecimal values.

#### **LOCATION 303 Global Reporting Code 4**

This location is used to configure global reporting codes to be used in the event that Neither Contact ID or SIA formats are used. These codes will be used when any of the other formats in Communications Setup - Advanced have been selected.

- **Sub-location 1 is Wireless Detector Supervision Failed**  
This code is reported when a wireless detector has not reported to the alarm panel after a certain amount of time.
- **Sub-location 2 is Wireless Detector Supervision Restore**  
This code is reported when a wireless detector restores communication with the alarm system.
- **Sub-location 3 is Wireless Receiver Signal Jammed**  
This code is reported when a wireless receiver detects a signal on the same frequency that is high enough to interfere with any signals from detectors.
- **Sub-location 4 is Wireless Detector Signal Restored**  
This code is reported when a wireless receiver detects that the signal affecting detector reporting has disappeared.
- **Sub-location 5 is Wireless Detector RSSI Low**  
This code is for reporting when the received signal strength indicator is lower than the required strength.
- **Sub-location 6 is Wireless Detector RSSI Restored**  
This code is for reporting when the received signal strength indicator is restored to the required strength.
- **Sub-location 7 is Dedicated Panic**  
This code is reported when the dedicated panic zone is violated. Option 7 in Table 43 needs to be enabled.
- **Sub-location 8 is Test Report**  
This code is reported at regular intervals (location 32). Option 8 in Table 43 needs to be enabled.
- **Sub-location 9 is Download Report Code**  
This is the code that will be sent after a successful connection has been made to the alarm panel with the download software.

 Enter a 2-digit reporting code for each of the 8 sub-locations and program as a 16-digit string, followed by the [\*] key.

**NOTE:** When programming using the string method, reserved sub-locations will still need data to be inputted into them to maintain the 16-digits needed to successfully program. Inputting data into a reserved sub-location will not affect the value of the sub-location. Reserved sub-locations have a value of 00.



[INSTALLER CODE] [\*] [3] [0] [3] [\*] [SUB-LOCATION] [\*] [REPORTING CODE] [\*]

The valid data range is: 01-FF, with 00 to disable.

If any of the sub-locations are disabled here, then the reporting codes will not report – even if they are enabled

Refer to Using Sub-locations to see how to scroll from one sub-location to another using the [\*] key.

**NOTE:** The values are hexadecimal. Refer to Table 3 on how to program hexadecimal values.

## Zone Reporting Codes

### LOCATIONS 304 – 307 Zone Alarm Reporting Code

The 2-digit zone alarm code is reported when the zone is violated during an arm cycle or if a Panic or 24-Hour zone is violated. Option 1 in Table 40 needs to be enabled.

Each location represents a set of 16 zones:

- Location 304 is zones 1-16      ➤ Location 305 is zones 17-32
- Location 306 is zones 33-48   ➤ Location 307 is zones 39-64



Enter a 2-digit reporting code for each of the 16 zones and program as a 32-digit string, followed by the [\*] key.



[INSTALLER CODE] [\*] [LOCATION] [\*] [ZONE NO.] [\*] [REPORTING CODE] [\*]

The valid data range is: 01-FF, with 00 to disable.

If any of the sub-locations are disabled here, then the reporting codes will not report – even if they are enabled

Refer to Using Sub-locations to see how to scroll from one sub-location to another using the [\*] key.

**NOTE:** The values are hexadecimal. Refer to Table 3 on how to program hexadecimal values.

### LOCATIONS 308 – 311 Zone Alarm Restoral Reporting Code

The 2-digit zone restoral code is reported when the zone has returned to the “unviolated” condition after triggering an alarm. Option 2 in Table 40 needs to be enabled.

Each location represents a set of 16 zones:

- Location 308 is zones 1-16      ➤ Location 309 is zones 17-32
- Location 310 is zones 33-48   ➤ Location 311 is zones 39-64



Enter a 2-digit reporting code for each of the 16 zones and program as a 32-digit string, followed by the [\*] key.



[INSTALLER CODE] [\*] [LOCATION] [\*] [ZONE NO.] [\*] [REPORTING CODE] [\*]

The valid data range is: 01-FF, with 00 to disable.

If any of the sub-locations are disabled here, then the reporting codes will not report – even if they are enabled

Refer to Using Sub-locations to see how to scroll from one sub-location to another using the [\*] key.

**NOTE:** The values are hexadecimal. Refer to Table 3 on how to program hexadecimal values.

## Contact ID Extended Feature

Locations 304 to 311 when using Contact ID now can be used to send different reporting codes to the control room when zones are violated.

The table below is a sample of values mapped to Contact ID codes, to see a complete list go to the appendix at the end of the manual.

Value	CID	Description
01	100	Medical Zone
02	101	Personal Emergency Zone

Value	CID	Description
3C	303	RAM Checksum bad Zone
3D	304	ROM checksum bad Zone

**Example:**

You have connected a panic button to zone 8, which has a zone type of 3, panic zone for a granny flat and the person has a health issue and may need medical help from time to time. By programming location 304 sub-



location 8 with the value 01, when zone 8 is triggered the Contact ID code 100 which is medical zone will be sent to the security company to alert them to send medical help.

Please see the appendix for the complete table of values for the Contact ID reporting codes

### LOCATIONS 312 – 315 Zone Tamper Reporting Code

The 2-digit tamper code is reported if tamper by zone has been enabled and a zone tamper occurs. Option 5 in Table 40 needs to be enabled.

Each location represents a set of 16 zones:

- Location 312 is zones 1-16
- Location 313 is zones 17-32
- Location 314 is zones 33-48
- Location 315 is zones 39-64

 Enter a 2-digit reporting code for each of the 16 zones and program as a 32-digit string, followed by the [\*] key.

 **[INSTALLER CODE] [\*] [LOCATION] [\*] [ZONE NO.] [\*] [REPORTING CODE] [\*]**

The valid data range is: 01-FF, with 00 to disable.

If any of the sub-locations are disabled here, then the reporting codes will not report – even if enabled at 0 Refer to Using Sub-locations to see how to scroll through sub-locations using the [\*] key.

**NOTE:** The values are hexadecimal. Refer to Table 3 on how to program hexadecimal values.

### LOCATIONS 316 – 319 Zone Tamper Restore Reporting Code

The 2-digit tamper restore code is reported when a zone tamper has been cleared. Option 6 in Table 40 needs to be enabled.

Each location represents a set of 16 zones:

- Location 316 is zones 1-16
- Location 317 is zones 17-32
- Location 318 is zones 33-48
- Location 319 is zones 39-64

 Enter a 2-digit reporting code for each of the 16 zones and program as a 32-digit string, followed by the [\*] key.

 **[INSTALLER CODE] [\*] [LOCATION] [\*] [ZONE NO.] [\*] [REPORTING CODE] [\*]**

The valid data range is: 01-FF, with 00 to disable.

If any of the sub-locations are disabled here, then the reporting codes will not report – even if enabled at 0 Refer to Using Sub-locations to see how to scroll through sub-locations using the [\*] key.

**NOTE:** The values are hexadecimal. Refer to Table 3 on how to program hexadecimal values.

### LOCATIONS 320 – 323 Zone Bypass Reporting Code

The 2-digit zone bypass code is reported when a zone has been bypassed while the panel is armed. Option 3 in Table 40 needs to be enabled.

Each location represents a set of 16 zones:

- Location 320 is zones 1-16
- Location 321 is zones 17-32
- Location 322 is zones 33-48
- Location 323 is zones 39-64

 Enter a 2-digit reporting code for each of the 16 zones and program as a 32-digit string, followed by the [\*] key.

 **[INSTALLER CODE] [\*] [LOCATION] [\*] [ZONE NO.] [\*] [REPORTING CODE] [\*]**

The valid data range is: 01-FF, with 00 to disable.

If any of the sub-locations are disabled here, then the reporting codes will not report – even if enabled at 0 Refer to Using Sub-locations to see how to scroll through sub-locations using the [\*] key.

**NOTE:** The values are hexadecimal. Refer to Table 3 on how to program hexadecimal values.

### LOCATIONS 324 – 327 Zone Force Arm Reporting Code

The 2-digit force zone arm code is transmitted if a partition is programmed to allow forced arming (arming with a violated zone) and a zone is violated at the time of arming. Option 4 in Table 40 needs to be enabled.

Each location represents a set of 16 zones:

- Location 324 is zones 1-16
- Location 325 is zones 17-32
- Location 326 is zones 33-48
- Location 327 is zones 39-64

 Enter a 2-digit reporting code for each of the 16 zones and program as a 32-digit string, followed by the [\*] key.



[INSTALLER CODE] [\*] [LOCATION] [\*] [ZONE NO.] [\*] [REPORTING CODE] [\*]

The valid data range is: 01-FF, with 00 to disable.

If any of the sub-locations are disabled here, then the reporting codes will not report – even if enabled at 0

Refer to Using Sub-locations to see how to scroll through sub-locations using the [\*] key.

**NOTE:** The values are hexadecimal. Refer to Table 3 on how to program hexadecimal values.

### LOCATIONS 328 – 331 Zone Swinger Shutdown Reporting Code

The 2-digit swinger shutdown zone code is reported if the system is armed and a zone is automatically bypassed as a result of multiple violations of that zone. Option 7 in Table 40 needs to be enabled.

Each location represents a set of 16 zones:

- Location 328 is zones 1-16
- Location 329 is zones 17-32
- Location 330 is zones 33-48
- Location 331 is zones 39-64



Enter a 2-digit reporting code for each of the 16 zones and program as a 32-digit string, followed by the [\*] key.



[INSTALLER CODE] [\*] [LOCATION] [\*] [ZONE NO.] [\*] [REPORTING CODE] [\*]

The valid data range is: 01-FF, with 00 to disable.

If any of the sub-locations are disabled here, then the reporting codes will not report

Refer to Using Sub-locations to see how to scroll from one sub-location to another using the [\*] key.

**NOTE:** The values are hexadecimal. Refer to Table 3 on how to program hexadecimal values.

### LOCATIONS 332 – 335 Zone Swinger Shutdown Restore Reporting Code

The 2-digit zone swinger shutdown restore code is reported when a swinger shutdown zone is automatically restored i.e. un-bypassed. Option 8 in Table 40 needs to be enabled.

Each location represents a set of 16 zones:

- Location 332 is zones 1-16
- Location 333 is zones 17-32
- Location 334 is zones 33-48
- Location 335 is zones 39-64



Enter a 2-digit reporting code for each of the 16 zones and program as a 32-digit string, followed by the [\*] key.



[INSTALLER CODE] [\*] [LOCATION] [\*] [ZONE NO.] [\*] [REPORTING CODE] [\*]

The valid data range is: 01-FF, with 00 to disable.

If any of the sub-locations are disabled here, then the reporting codes will not report

Refer to Using Sub-locations to see how to scroll through sub-location using the [\*] key.

**NOTE:** The values are hexadecimal. Refer to Table 3 on how to program hexadecimal values.

## Partition Reporting Codes

### LOCATION 336 Duress Reporting Code

The 2-digit duress code is reported when a duress code is entered into any keypad belonging to the specified partition. Option 1 in Table 46 needs to be enabled.



Enter a 2-digit reporting code for each of the 8 partitions and program as a 16-digit string, followed by the [\*] key.



[INSTALLER CODE] [\*] [3] [3] [6] [\*] [PARTITION NO.] [\*] [REPORTING CODE] [\*]

The valid data range is: 01-FF, with 00 to disable.

If any of the sub-locations are disabled here, then the reporting codes will not report – even if enabled

Partition no. is: 1-8.

Refer to Using Sub-locations to see how to scroll through sub-location using the [\*] key.

**NOTE:** The values are hexadecimal. Refer to Table 3 on how to program hexadecimal values.

### LOCATION 337 Keypad Panic Reporting Code

This location is configured per partition. This 2-digit code is reported when the [P] key on any keypad belonging to the specified partition is held down for two seconds. Option 2 in Table 46 needs to be enabled.



Enter a 2-digit reporting code for each of the 8 partitions and program as a 16-digit string, followed by the [\*] ke2y.

**[INSTALLER CODE] [\*] [3] [3] [7] [\*] [PARTITION NO.] [\*] [REPORTING CODE] [\*]**

The valid data range is: 01-FF, with 00 to disable.

If any of the sub-locations are disabled here, then the reporting codes will not report – even if they are enabled

Partition no. is: 1-8.

Refer to Using Sub-locations to see how to scroll through sub-location using the [\*] key.

**NOTE:** The values are hexadecimal. Refer to Table 3 on how to program hexadecimal values.

### LOCATION 338 Fire Reporting Code

The 2-digit fire code is reported when the [F] key on any keypad belonging to the specified partition is held down for two seconds. Option 3 in Table 46 needs to be enabled.



Enter a 2-digit reporting code for each of the 8 partitions and program as a 16-digit string, followed by the [\*] key.

**[INSTALLER CODE] [\*] [3] [3] [8] [\*] [PARTITION NO.] [\*] [REPORTING CODE] [\*]**

The valid data range is: 01-FF, with 00 to disable.

If any of the sub-locations are disabled here, then the reporting codes will not report – even if they are enabled

Partition no. is: 1-8.

Refer to Using Sub-locations to see how to scroll from one sub-location to another using the [\*] key.

**NOTE:** The values are hexadecimal. Refer to Table 3 on how to program hexadecimal values.

### LOCATION 339 Medical Reporting Code

The 2-digit medical code is reported when the [M] key on any keypad belonging to the specified partition is held down for two seconds. Option 4 in Table 46 needs to be enabled.



Enter a 2-digit reporting code for each of the 8 partitions and program as a 16-digit string, followed by the [\*] key.

**[INSTALLER CODE] [\*] [3] [3] [9] [\*] [PARTITION NO.] [\*] [REPORTING CODE] [\*]**

The valid data range is: 01-FF, with 00 to disable.

If any of the sub-locations are disabled here, then the reporting codes will not report – even if enabled at 0

Partition no. is: 1-8.

Refer to Using Sub-locations to see how to scroll from one sub-location to another using the [\*] key.

**NOTE:** The values are hexadecimal. Refer to Table 3 on how to program hexadecimal values.

### LOCATION 340 Keypad Lockout Reporting Code

The 2-digit keypad lockout code is reported when a keypad lockout condition occurs on any keypad belonging to the specified partition. Option 5 in Table 46 needs to be enabled.



Enter a 2-digit reporting code for each of the 8 partitions and program as a 16-digit string, followed by the [\*] key.

**[INSTALLER CODE] [\*] [3] [4] [0] [\*] [PARTITION NO.] [\*] [REPORTING CODE] [\*]**

The valid data range is: 01-FF, with 00 to disable.

If any of the sub-locations are disabled here, then the reporting codes will not report – even if enabled at 0

Partition no. is: 1-8.

Refer to Using Sub-locations to see how to scroll from one sub-location to another using the [\*] key.

**NOTE:** The values are hexadecimal. Refer to Table 3 on how to program hexadecimal values.

## User Reporting Codes

### LOCATIONS 342 – 349 Close Reporting Code

The 2-digit close code is reported when the panel is AWAY ARMED. This location is configured per user. Refer to the User Manual where option 1 of User Reporting Codes Enabled, needs to be enabled.

Each location represents a set of 16 users:

- Location 342 are users 1-16
- Location 343 are users 17-32
- Location 344 are users 33-48
- Location 345 are users 39-64
- Location 346 are users 65-80
- Location 347 are users 81-96
- Location 348 are users 97-112
- Location 349 are users 113-128



Enter a 2-digit reporting code for each of the 16 users and program as a 32-digit string, followed by the [\*] key.



**[INSTALLER CODE] [\*] [LOCATION] [\*] [USER] [\*] [REPORTING CODE] [\*]**

The valid data range is: 01-FF, with 00 to disable.

If any of the sub-locations are disabled here, then the reporting codes will not report – even if enabled at 0

Refer to Using Sub-locations to see how to scroll through sub-location using the [\*] key1y.

**NOTE:** The values are hexadecimal. Refer to Table 3 on how to program hexadecimal values.

### LOCATIONS 350 – 357 Stay Close Reporting Code

The 2-digit stay close code is reported when the panel is STAY ARMED. This location is configured per user. Refer to the User Manual where option 2 of User Reporting Codes Enabled, needs to be enabled.

Each location represents a set of 16 users:

- Location 350 are users 1-16
- Location 352 are users 33-48
- Location 354 are users 65-80
- Location 356 are users 97-112
- Location 351 are users 17-32
- Location 353 are users 39-64
- Location 355 are users 81-96
- Location 357 are users 113-128



Enter a 2-digit reporting code for each of the 16 users and program as a 32-digit string, followed by the [\*] key.



**[INSTALLER CODE] [\*] [LOCATION] [\*] [USER] [\*] [REPORTING CODE] [\*]**

The valid data range is: 01-FF, with 00 to disable.

If any of the sub-locations are disabled here, then the reporting codes will not report – even if enabled at 0

Refer to section 0 Using Sub-locations to see how to scroll through sub-location using the [\*] key.

**NOTE:** The values are hexadecimal. Refer to Table 3 on how to program hexadecimal values.

### LOCATIONS 358 – 365 Open Reporting Code

The 2-digit open code is reported when the panel is DISARMED. This location is configured per user. Refer to the User Manual where option 3 of User Reporting Codes Enabled, needs to be enabled.

Each location represents a set of 16 users:

- Location 358 are users 1-16
- Location 360 are users 33-48
- Location 362 are users 65-80
- Location 364 are users 97-112
- Location 359 are users 17-32
- Location 361 are users 39-64
- Location 363 are users 81-96
- Location 365 are users 113-128



Enter a 2-digit reporting code for each of the 16 users and program as a 32-digit string, followed by the [\*] key.



**[INSTALLER CODE] [\*] [LOCATION] [\*] [USER] [\*] [REPORTING CODE] [\*]**

The valid data range is: 01-FF, with 00 to disable.

If any of the sub-locations are disabled here, then the reporting codes will not report – even if enabled

Refer to section 0 Using Sub-locations to see how to scroll from one sub-location to another using the [\*] key.

**NOTE:** The values are hexadecimal. Refer to Table 3 on how to program hexadecimal values.

### LOCATIONS 366 – 373 Siren Cancel Reporting Codes

The 2-digit siren cancel code is reported when the siren is CANCELLED. This location is configured per user. Refer to the User Manual where option 4 of User Reporting Codes Enabled, needs to be enabled.

Each location represents a set of 16 users:

- Location 366 are users 1-16
- Location 368 are users 33-48
- Location 370 are users 65-80
- Location 372 are users 97-112
- Location 367 are users 17-32
- Location 369 are users 39-64
- Location 371 are users 81-96
- Location 373 are users 113-128



Enter a 2-digit reporting code for each of the 16 users and program as a 32-digit string, followed by the [\*] key.



### [INSTALLER CODE] [\*] [LOCATION] [\*] [USER] [\*] [REPORTING CODE] [\*]

The valid data range is: 01-FF, with 00 to disable.

If any of the sub-locations are disabled here, then the reporting codes will not report – even if they are enabled

Refer to section 0 Using Sub-locations to see how to scroll through sub-location using the [\*] key.

**NOTE:** The values are hexadecimal. Refer to Table 3 on how to program hexadecimal values.

Canceling a Silent Alarm or Silent Panic will not cause the cancel siren code to be reported.

#### LOCATIONS 374 Quick Close Reporting Codes

Locations to enter reporting codes if you want to report when a user uses the quick arm key to arm, to the control room. This is for formats other than Contact ID and SIA. Default is 00.

#### LOCATIONS 375 Quick Stay Reporting Codes

Locations to enter reporting codes if you want to report when a user uses the quick stay arm key to arm, to the control room. This is for formats other than Contact ID and SIA. Default is 00.

### Programmable Outputs

#### Output Disarm Clear

#### LOCATION 380 Clear Programmable Onboard Outputs on Disarming

This bitmapped location allows onboard programmable outputs 1-5 to be cleared (set low) on disarming. The output/s to be cleared will be displayed by zone number LEDs. The programmable outputs will clear when ANY partition is disarmed. Refer to Table 30 to view which zone number LED corresponds to which onboard output.

Regardless of which partition they are allocated to, disarming any partition will clear these outputs.

**Table 30: Clear Programmable Onboard Outputs Data**

LED	Disarm Clear Output	LED	Disarm Clear Output	LED	Disarm Clear Output
1	Output 1	3	Output 3	5	Output 5
2	Output 2	4	Output 4		

#### LOCATIONS 381 – 386 Clear Programmable Zone Expander Outputs on Disarming

This bitmapped location allows the 2 outputs of the 6 zone expanders to be cleared (set low) on disarming. The output(s) to be cleared will be displayed by zone number LEDs. The programmable outputs will clear when ANY partition is disarmed. Refer to Table 31 to view which zone number LED corresponds to which zone expander output. These are only available on X64.

Each location represents a zone expander:

- Location 381 represents zone expander 1
- Location 382 represents zone expander 2
- Location 383 represents zone expander 3
- Location 384 represents zone expander 4
- Location 385 represents zone expander 5
- Location 386 represents zone expander 6

**Table 31: Clear Programmable Zone Expander Outputs Data**

LED	Output
1	Output 1
2	Output 2

#### LOCATION 389 Clear Programmable Keypad Outputs on Disarming

This bitmapped location allows the single outputs of the 8 keypads to be cleared (set low) on disarming. The output/s to be cleared will be displayed by zone number LEDs. The programmable outputs will clear when ANY partition is disarmed. Refer to Table 32 to view which zone number LED corresponds to which keypad output.

**Table 32: Clear Programmable Keypad Outputs Data**

LED	Output	LED	Output	LED	Output	LED	Output
1	Keypad 1	3	Keypad 3	5	Keypad 5	7	Keypad 7
2	Keypad 2	4	Keypad 4	6	Keypad 6	8	Keypad 8

## Partition Event Driven Outputs – Advanced

The following locations determine allow you to assign outputs and output actions to partition events for each partition.

### LOCATIONS 390 – 414 Partition Programmable Output Events

These locations allow you to configure various programmable output events per partition. See locations 423-426, “Global Programmable Output Events” for details on programming the programmable output events.

Only one output and action can be assigned per partition, unless otherwise stated. The maximum current available from a programmable output is 80mA.

For zone and keypad events, any zone or keypad assigned to a particular partition being programmed will trigger an output if that event occurs.

On an LED keypad, LEDs 1-8 represent the output number, and LEDs 9-16 represent the action.

**NOTE:** Each location has eight sub-locations one for each partition. E.g. sub-location 1 is partition1, sub-location 2 is partition 2, etc.

 Enter a 4-digit value (2 digits as per Table 33 and 2 digits as per Table 34) for each partition and program as a 32-digit string, followed by the [\*] key.

**[INSTALLER CODE] [\*] [LOCATION] [\*] [PARTITION] [\*] [OUTPUT] [ACTION] [\*]**

**NOTE:** Only an output can be entered for programmable output events 411-414.

 Enter a 2-digit value for each partition and program as a 16-digit string, followed by the [\*] key.

**[INSTALLER CODE] [\*] [LOCATION] [\*] [PARTITION NO.] [\*] [OUTPUT] [\*]**

Partition no. is: 1-8.

#### **A NOTE ON ARM FOLLOW:**

An output which has been set as an Arm Follow Programmable Output Event will mimic the ARM LED on the keypad. The output will be set High when the partition is armed, set Low when the partition is disarmed, and will flash when the partition has an alarm condition. The benefit of this is that you can attach a siren, Remote Arm/Disarm LED Unit (862-84-10), etc to your Alarm Panel for an audible/visual display of the panel’s state.

Table 33 lists the addresses for the physical outputs and Table 34 lists the output actions.

**Table 33: Output Address Physical Mapping Data**

Address	Physical Outputs	Address	Physical Outputs	Address	Physical Outputs
00	Disabled	09	Zone expander 2 output 2	18 – 33	Reserved
01	Onboard output 1	10	Zone expander 3 output 1	34	Keypad 1 output
02	Onboard output 2	11	Zone expander 3 output 2	35	Keypad 2 output
03	Onboard output 3	12	Zone expander 4 output 1	36	Keypad 3 output
04	Onboard output 4	13	Zone expander 4 output 2	37	Keypad 4 output
05	Onboard output 5	14	Zone expander 5 output 1	38	Keypad 5 output
06	Zone expander 1 output 1	15	Zone expander 5 output 2	39	Keypad 6 output
07	Zone expander 1 output 2	16	Zone expander 6 output 1	40	Keypad 7 output
08	Zone expander 2 output 1	17	Zone expander 6 output 2	41	Keypad 8 output

**Table 34: Output Actions Data**

Value	Output Action	Value	Output Action
00	Set Output High (Set)	02	Pulse Output High
01	Set Output Low (Reset)	03	Pulse Output Low

**Table 35** lists the default output and action for locations 390-414.

**Table 35: Default Programmable Events Data**

Loc	Event	Default Output	Default Action
390	Close Programmable Output Event	Output 3 [03]	Set High [00]
391	Stay Close Programmable Output Event	Disabled [00]	
392	Open Programmable Output Event	Output 3 [03]	Set Low [01]
393	Cancel Programmable Output Event	Disabled [00]	
394	Alarm Restoral Programmable Output Event	Disabled [00]	
395	Bypass Programmable Output Event	Disabled [00]	
396	Forced Arm Programmable Output Event	Disabled [00]	
397	Zone Tamper Programmable Output Event	Disabled [00]	
398	Zone Tamper Restoral Programmable Output Event	Disabled [00]	
399	Zone Shutdown Programmable Output Event	Disabled [00]	
400	Zone Shutdown Restoral Programmable Output Event	Disabled [00]	
401	Keypad Panic Programmable Output Event	Output 1 [01]	Pulse High [02]
402	Keypad Fire Programmable Output Event	Output 4 [04]	Pulse High [02]
403	Keypad Medical Programmable Output Event	Output 5 [05]	Pulse High [02]
404	Keypad Lockout Programmable Output Event	Disabled [00]	
405	Duress Programmable Output Event	Output 1 [01]	Pulse High [02]
406	Verifies Alarm Programmable Output Event	Disabled [00]	
407	Burglary Programmable Output Event	Output 2 [02]	Pulse High [02]
408	Panic Programmable Output Event	Output 1 [01]	Pulse High [02]
409	Fire Programmable Output Event (Refer to Table 5)	Output 4 [04]	Pulse High [02]
410	Tamper Zone Programmable Output Event	Disabled [00]	

**Table 36: Default Programmable Events Data with no Default Action**

Loc	Event	Default Output
411	Siren Programmable Output Event	Disabled [00]
412	Strobe Programmable Output Event	Disabled [00]
413	Chime Programmable Output Event	Disabled [00]
414	Arm Follow Programmable Output Event	Disabled [00]

**NOTE:** Once a programmable output has been enabled, the default action will be Pulse High [02].

### Zone Programmable Output Events

The following locations are used to program the various zone outputs.

#### LOCATIONS 415 – 422 Zone Programmable Output Events

An output can be assigned to a zone so when the zone causes an alarm condition, the chosen output performs the selected option. A list of available actions and their corresponding values is shown in Table 34.

Table 36 Regardless of the action selected for a particular output, if it is programmed to clear on disarming of the panel (locations 380-389), the output will revert to clear (set low) after any partition disarmed.

Each location represents a set of 8 zones:

- Location 415 zones 1-8                      ➤ Location 416 zones 9-16                      ➤ Location 417 zones 17-24
- Location 418 zones 25-32                   ➤ Location 419 are zones 33-40               ➤ Location 420 zones 41-48
- Location 421 zones 49-56                   ➤ Location 422 zones 57-64



Enter a 4-digit output and action for each of the 8 zones and program as 32-digit strings, followed by the [\*] key.



**[INSTALLER CODE] [\*] [4] [1] [5] [\*] [ZONE NO.] [\*] [OUTPUT] [ACTION] [\*]**

Refer to Programming Standard Locations to see how to scroll through data in a location using the [\*] key.

## LOCATIONS 423 – 426 Global Programmable Output Events

These locations allow you to configure the global programmable output events. Refer to Table 37 to view the programmable output events per location.

- LEDs 1-8 represent the output number, and LEDs 9-16 represent the action. Once a programmable output has been enabled, the default action will be Pulse High [02].
- If dual reporting is enabled, an output allocated to the dual reporting programmable output event will be set when the panel dials the second phone number, and cleared when it hangs up at the end of the transmission. This output follows the hook relay. It may be used to trigger switching from the telephone line to a radio transmitter.
- There is no output action for the fire sensor power and dual reporting programmable output events.

**Table 37: Global Programmable Output Events Default Data**

Loc	Sub-loc	Event	Default Output	Default Action
423	1	AC Fail Programmable Output Event	Disabled [00]	
	2	AC Restore Programmable Output Event	Disabled [00]	
	3	Low Battery Programmable Output Event	Disabled [00]	
	4	Low Battery Restore Programmable Output Event	Disabled [00]	
	5	Auto Test Programmable Output Event	Disabled [00]	
	6	Download Programmable Output Event	Disabled [00]	
	7	Siren Tamper Programmable Output Event	Disabled [00]	
	8	Aux 12V Trouble Programmable Output Event	Disabled [00]	
424	1	Reserved	Disabled [00]	
	2	Bus-wired Peripheral Tamper Programmable Output Event	Disabled [00]	
	3	Bus-wired Peripheral Fail Programmable Output Event	Disabled [00]	
	4	Box Tamper Programmable Output Event	Disabled [00]	
	5	Dedicated Panic Programmable Output Event	<b>Output [01]</b>	<b>Pulse High [02]</b>
	6	Communication Fail Programmable Output Event	Disabled [00]	
	7	Telephone Line Tamper Programmable Output Event	Disabled [00]	
	8	Telephone Line Restore Programmable Output Event	Disabled [00]	
426	1	Wired Zone Expander Low Battery Programmable Output Event	Disabled [00]	
	2	Wired Zone Expander Low Battery Restore Programmable Output Event	Disabled [00]	
	3	Fire Sensor Power Programmable Output Event	Disabled [00]	No Action
	4	Dual Reporting Programmable Output Event	Disabled [00]	No Action



Enter a 4-digit value (2 digits as per Table 33 and 2 digits as per Table 34 for each programmable output and program as a 32-digit string, followed by the [\*] key.

**[INSTALLER CODE] [\*] [LOCATION] [\*] [SUB-LOCATION] [\*] [OUTPUT] [ACTION] [\*]**

Refer to Using Sub-locations to see how to scroll through sub-location using the [\*] key.

**NOTE:** Once a programmable output has been enabled, the default action will be Pulse High [02].

### Output Pulse Timing - Advanced

The following locations determine the length of time for which an output will pulse high before returning to a clear state.

#### LOCATION 428 Onboard Output Pulse Time (default = 0002)



Enter a 4-digit time, [MMSS], for each of the 5 onboard outputs and program as a 20-digit string, followed by the [\*] key.



**[INSTALLER CODE] [\*] [4] [2] [8] [\*] [OUTPUT NO.] [\*] [MMSS] [\*]**

The valid data range is: 00m00s – 59m59s.

Output no. is: 1-5.



#### LOCATION 429 – 434 Zone Expander Output Pulse Time (default = 0002)

 Enter a 4-digit time, [MMSS], for each of the 6 zone expanders output and program as an 8-digit string, followed by the [\*] key.

 [INSTALLER CODE] [\*] [LOCATION] [\*] [OUTPUT NO.] [\*] [MMSS] [\*]

The valid data range is: 00m00s – 59m59s.

Output no. is: 1-2.

Refer to Using Sub-locations to see how to scroll through sub-location using the [\*] key.

#### LOCATION 437 Keypad Output Pulse Time (default = 0002)

 Enter a 4-digit time, [MMSS], for each of the 8 keypads output and program as a 32-digit string, followed by the [\*] key.

 [INSTALLER CODE] [\*] [4] [3] [7] [\*] [OUTPUT NO.] [\*] [MMSS] [\*]

The valid data range is: 00m00s – 59m59s.

Output no. is: 1-8.

### Output Scheduling On Time - Advanced

The following locations determine the time of day for each of the programmable outputs to turn on/off. These outputs can either be set high (on) or low (off). For the following locations to work the appropriate on/off days (locations 458-498), must be selected.

#### LOCATION 438 Onboard Output ON Time (default = 2400)

 Enter a 4-digit time, [HHMM], for each of the 5 onboard outputs and program as a 20-digit string, followed by the [\*] key.

 [INSTALLER CODE] [\*] [4] [3] [8] [\*] [OUTPUT NO.] [\*] [HHMM] [\*]

The valid data range is: 00h00m – 23h59m, with 24h00m to disable.

Output no. is: 1-5.

#### LOCATION 439 – 444 Zone Expander Output ON Time (default = 2400)

 Enter a 4-digit time, [HHMM], for each of the 6 zone expanders output and program as an 8-digit string, followed by the [\*] key.

 [INSTALLER CODE] [\*] [LOCATION] [\*] [OUTPUT NO.] [\*] [HHMM] [\*]

The valid data range is: 00h00m – 23h59m, with 24h00m to disable.

Output no. is: 1-2.

Refer to Using Sub-locations to see how to scroll through sub-location using using the [\*] key.

#### LOCATION 447 Keypad Output ON Time (default = 2400)

 Enter a 4-digit time, [HHMM], for each of the 8 keypads output and program as a 32-digit string, followed by the [\*] key.

 [INSTALLER CODE] [\*] [4] [4] [7] [\*] [OUTPUT NO.] [\*] [HHMM] [\*]

The valid data range is: 00h00m – 23h59m, with 24h00m to disable.

Output no. is: 1-8.

### Output Scheduling Off Time - Advanced

The following locations determine the programmed time for the programmable output to turn off. These outputs can either be set high (on) or low (off). For the following locations to work the appropriate on/off days (locations 458-498), must be selected.

#### LOCATION 448 Onboard Output OFF Time (default = 2400)

 Enter a 4-digit time, [HHMM], for each of the 5 onboard outputs and program as a 20-digit string, followed by the [\*] key.

 [INSTALLER CODE] [\*] [4] [4] [8] [\*] [OUTPUT NO.] [\*] [HHMM] [\*]

The valid data range is: 00h00m – 23h59m, with 24h00m to disable.

Output no. is: 1-5.

**LOCATION 449 – 454 Zone Expander Output OFF Time (default = 2400)**

 Enter a 4-digit time, [HHMM], for each of the 6 zone expander outputs and program as an 8-digit string, followed by the [\*] key.

 [INSTALLER CODE] [\*] [LOCATION] [\*] [OUTPUT NO.] [\*] [HHMM] [\*]

The valid data range is: 00h00m – 23h59m, with 24h00m to disable.

Output no. is: 1-2.

Refer to Using Sub-locations to see how to scroll through sub-location using the [\*] key.

**LOCATION 457 Keypad Output OFF Time (default = 2400)**

 Enter a 4-digit time, [HHMM], for each of the 8 keypad outputs and program as a 32-digit string, followed by the [\*] key.

 [INSTALLER CODE] [\*] [4] [5] [7] [\*] [OUTPUT NO.] [\*] [HHMM] [\*]

The valid data range is: 00h00m – 23h59m, with 24h00m to disable.

Output no. is: 1-8.

**Output Scheduling On/Off Days - Advanced**

Outputs can be scheduled to set and reset at specified times on specific days of the week. To disable scheduling of an output ensure that all “days” are deselected.

**LOCATIONS 458 – 498 Output On/Off Days**

 The on/off days for the outputs, to turn on or off, in Table 39 can be programmed by using the values in Table 38.

**Table 38: Output Scheduling On/Off Days Data**

LED	ON Days of the Week
1	Monday
2	Tuesday
3	Wednesday
4	Thursday
5	Friday
6	Saturday
7	Sunday
All OFF	(Arm Day Disabled)

LED	OFF Days of the Week
9	Monday
10	Tuesday
11	Wednesday
12	Thursday
13	Friday
14	Saturday
15	Sunday
All OFF	(Disarm Day Disabled)

**Table 39: Outputs per Location**

Loc.	Event
458	Onboard Output 1
459	Onboard Output 2
460	Onboard Output 3
461	Onboard Output 4
462	Onboard Output 5
463	Zone Expander 1, Output 1
464	Zone Expander 1, Output 2
465	Zone Expander 2, Output 1
466	Zone Expander 2, Output 2
467	Zone Expander 3, Output 1
468	Zone Expander 3, Output 2
469	Zone Expander 4, Output 1
470	Zone Expander 4, Output 2

Loc.	Event	Output
471	Zone Expander 5, Output 1	Refer to Table 38
472	Zone Expander 5, Output 2	Refer to Table 38
473	Zone Expander 6, Output 1	Refer to Table 38
474	Zone Expander 6, Output 2	Refer to Table 38
491	Keypad 1	Refer to Table 38
492	Keypad 2	Refer to Table 38
493	Keypad 3	Refer to Table 38
494	Keypad 4	Refer to Table 38
495	Keypad 5	Refer to Table 38
496	Keypad 6	Refer to Table 38
497	Keypad 7	Refer to Table 38
498	Keypad 8	Refer to Table 38

## Event Reporting Options - Advanced

The following locations from 501-588 enable/disable the reporting of events programmed into locations 300-373. If a reporting code has been programmed, and the reporting of that code is not enabled here – then the reporting code will not report.

**Note: Default values indicated in the default column**

The valid data range in location 501 to 589 options 1 to 8, Actions, and options 9 to 16, Reporting Pair are:

Valid data range options 1 to 8	Valid data range options 9 to 16
ON = Enable	ON = Telephone module 2
OFF = Disable	OFF = Telephone module 1

### LOCATIONS 501 – 564 Split Reporting Zones 1 - 64

 Locations 501 (zone 1) – 564 (zone 64) represent a bitmap of 64 split reporting zone locations.

**Table 40: Split Reporting Zones Bitmap Data**

LED	Default	Action	LED	Default	Reporting Pair
1	ON	Zone alarm reporting	9	OFF	Telephone module 1
2	OFF	Zone alarm restore reporting	10	OFF	Telephone module 1
3	OFF	Disable zone bypass reporting	11	OFF	Telephone module 1
4	OFF	Zone force arm reporting	12	OFF	Telephone module 1
5	OFF	Zone tamper reporting	13	OFF	Telephone module 1
6	OFF	Zone tamper restore reporting	14	OFF	Telephone module 1
7	OFF	Zone swinger shutdown reporting	15	OFF	Telephone module 1
8	OFF	Zone swinger shutdown restore reporting	16	OFF	Telephone module 1

**NOTE:** See Communications Setup - Advanced.

### LOCATION 571 Global Split Reporting 1

 **Table 41: Global Split Reporting 1 Bitmap Data**

LED	Default	Action	LED	Default	Reporting Pair
1	ON	AC fail reporting	9	OFF	Telephone module 1
2	OFF	Communication fail reporting *	10	OFF	Telephone module 1
3	ON	Telephone line tamper reporting	11	OFF	Telephone module 1
4	ON	Siren fail reporting	12	OFF	Telephone module 1
5	ON	Panel low battery fail reporting	13	OFF	Telephone module 1
6	ON	Aux 12V fuse fail reporting	14	OFF	Telephone module 1
7	OFF	Installer Reset Required	15	OFF	Telephone module 1
8	ON	Box tamper reporting	16	OFF	Telephone module 1

\* The reporting code is only supported by Contact ID or SIA, and thus will not be reported if any other format has been selected.

### LOCATION 572 Global Split Reporting 2

 **Table 42: Global Split Reporting 2 Bitmap Data**

LED	Default	Action	LED	Default	Reporting Pair
1	ON	Bus-wired peripheral tamper reporting	9	OFF	Telephone module 2
2	ON	Bus-wired peripheral fail reporting	10	OFF	Telephone module 2
3	OFF	Bus-wired peripheral low battery reporting *	11	OFF	Telephone module 1
4	OFF	Wireless Detector Battery Low	12	OFF	Telephone module 1
5	OFF	Wireless Detector Supervision fail	13	OFF	Telephone module 1
6	OFF	Wireless Receiver Signal Jammed	14	OFF	Telephone module 1
7	OFF	Wireless Detector RSSI Low	15	OFF	Telephone module 1
8	ON	AC Restored	16	OFF	Telephone module 1

\* The reporting code is only supported by Contact ID, and thus will only be reported if Contact ID has been selected.

\*\*The reporting code is only supported by Contact ID or SIA, and thus will not be reported if any other format has been selected.

### LOCATION 573 Global Split Reporting 3

 Table 43: Global Split Reporting 3 Bitmap Data

LED	Default	Action	LED	Default	Reporting Pair
1	OFF	Comms Restored	9	OFF	Telephone module 1
2	OFF	Comms Tamper Restore	10	OFF	Telephone module 1
3	OFF	Siren Restore	11	OFF	Telephone module 1
4	ON	Battery Restore	12	OFF	Telephone module 1
5	OFF	Aux 12V Restored	13	OFF	Telephone module 1
6	OFF	Installer Reset restored	14	OFF	Telephone module 1
7	OFF	Box tamper restored	15	OFF	Telephone module 1
8	OFF	Bus device tamper restored	16	OFF	Telephone module 1

\*The reporting code is only supported by Contact ID or SIA, and thus will not be reported if any other format has been selected.

\*\* The reporting code is only supported by Contact ID, and thus will only be reported if Contact ID has been selected.

### LOCATION 574 Global Split Reporting 4

 Table 44: Global Split Reporting 4 Bitmap Data

LED	On/Off	Action	LED	On/Off	Reporting Pair
1	OFF	Bus device comms restored	9	OFF	Telephone module 1
2	OFF	Bus device battery restored	10	OFF	Telephone module 1
3	OFF	Wireless detector battery restored	11	OFF	Telephone module 1
4	OFF	Wireless detector supervision restored	12	OFF	Telephone module 1
5	OFF	Wireless receiver jam restored	13	OFF	Telephone module 1
6	OFF	Wireless detector RSSI low restored	14	OFF	Telephone module 1
7	ON	Dedicated Panic	15	OFF	Telephone module 1
8	ON	Test Report	16	OFF	Telephone module 1

### LOCATION 575 Global Split Reporting 5

 Table 45: Global Split Reporting 5 Bitmap Data

LED	Default	Action	LED	Default	Reporting Pair
1	OFF	IDSwift Download Accessed	9	OFF	Telephone module 1

### LOCATIONS 581 – 588 Split Reporting Partitions 1-8

 Table 46: Split Reporting Partitions 1-8 Data

LED	Default	Action	LED	Default	Reporting Pair
1	ON	Duress reporting	9	OFF	Telephone module 2
2	ON	Keypad panic reporting	10	OFF	Telephone module 2
3	ON	Fire reporting	11	OFF	Telephone module 2
4	ON	Medical reporting	12	OFF	Telephone module 2
5	ON	Keypad lockout reporting	13	OFF	Telephone module 2
6	OFF	Reserved	14	OFF	Reserved
7	OFF	Disable armed without user code reporting	15	OFF	Telephone module 2
8	OFF	Reserved	16	OFF	Reserved

- Location 581 is partition 1
- Location 582 is partition 2
- Location 583 is partition 3
- Location 584 is partition 4
- Location 585 is partition 5
- Location 586 is partition 6
- Location 587 is partition 7
- Location 588 is partition 8

**LOCATION 589 Stay Zone Split Reporting Codes**

This is to enable stay zone reporting when using, Contact ID and to choose which group of split reporting numbers to report to.

Default is Telephone Module 1.

**11. Voice Module**

The Voice Module is a plug-in board for X-series alarm panel. The board contains a DMTF decoder chip and a flash memory chip which add telephonic voice interaction to the panel.

The user can receive alarm messages or can control the system via the phone by pressing keys on the phone. The user must enter their user code before any communication can take place. If the code is entered incorrectly three times the system will hang up.

**Note:** The X-series panels must have firmware version 1.07 or higher and hardware version “D” or higher.

**LOCATIONS 600 Master User Phone Number**

This phone number will receive all enabled reporting from all partitions.

**LOCATIONS 601 & 602 Partition 1 User Phone Number**

These numbers are for partition one reporting

**LOCATIONS 603 & 604 Partition 2 User Phone Number**

These numbers are for partition two reporting

**LOCATIONS 605 & 606 Partition 3 User Phone Number**

These numbers are for partition three reporting

**LOCATIONS 607 & 608 Partition 4 User Phone Number**

These numbers are for partition four reporting

**LOCATIONS 609 & 610 Partition 5 User Phone Number**

These numbers are for partition five reporting

**LOCATIONS 611 & 612 Partition 6 User Phone Number**

These numbers are for partition six reporting

**LOCATIONS 613 & 614 Partition 7 User Phone Number**

These numbers are for partition seven reporting

**LOCATIONS 615 & 616 Partition 8 User Phone Number**

These numbers are for partition eight reporting

**Note:** Please see the wireless manual for more instructions on how to setup the users

**LOCATIONS 617 User Reporting Codes Enable**

Enabling or disabling of user code reporting has now been moved from “user menu” to location 617 under the installer menu.

Option	Default	Action
1	ON	Close reporting
2	ON	Stay close reporting
3	ON	Open reporting
4	OFF	Siren cancel reporting
5	Reserved	Reserved
6	OFF	AC Fail reporting
7	OFF	AC restore reporting
8	OFF	Low battery reporting
9	OFF	Auto test reporting
10	OFF	Zone bypassing

## LOCATIONS 618 User Reporting Split Reporting

Selecting which telephone split reporting group to use when reporting. This has moved from “user menu” 15 to location 618 under the installer menu.

Option	Default	Action
1	OFF	Telephone Module 1
2	OFF	Telephone Module 1
3	OFF	Telephone Module 1
4	OFF	Telephone Module 1
5	Reserved	Reserved
6	OFF	Telephone Module 1
7	OFF	Telephone Module 1
8	OFF	Telephone Module 1
9	OFF	Telephone Module 1
10	OFF	Telephone Module 1

## 12. Keypad Information

### [1] and [3]

To view information for an individual keypad, press the [1] and [3] keys simultaneously and then quickly release.

The LCD keypad will display ‘Keypad Info’. Use the [PANIC] and [MED] keys to scroll through the available information.

- Lowest Zone This displays the start zone of the keypad (this is only applicable to LED keypad, therefore, the LCD keypad will always display 01)
- Highest Zone This displays the end zone of the keypad (this is only applicable to the LED keypad, therefore, the LCD keypad will always display 64)
- Zone Mask This displays the zones. The information is read from right to left. Each hex character displays information for 4 zones
- Version Nr This displays the version number of the keypad firmware
- Version Date This displays the date the version was created

When phoning the helpdesk for technical support, it is important to be able to give them the firmware version of the keypad. This will help with the troubleshooting process.

## 13. Panel Information

### [\*] [\*]

To view information for the panel, hold down the [\*] key to enter the user menu, then press the [\*] key again to enter into the panel information.

Use the [\*] key to scroll through the information.

- FW This displays the firmware version of the panel
- HW This displays the hardware version of the panel
- BL This displays the boot loader version of the panel
- BN This displays the build number of the panel

When phoning the helpdesk for technical support, it is important to be able to give them all (or at least) some of information for the panel. This will help with the troubleshooting process.

## 14. User Options

1. "Auto Test" option 97
2. New Partition Menu on LCD keypads
  - a. When entering quick arm, stay arm or stay go and the option is enabled all partitions will be shown with their status
  - b. Menu status options:
    - i. r = ready
    - ii. n = not ready
    - iii. E = entry/exit delay
    - iv. S = stay armed
    - v. A = away armed
    - vi. ! = alarm
3. Slot 1 Master code can add codes to all partitions.
  - a. Slot 2 to 128 can only add codes to their allocated partition
4. Manual PGM mode can be done even if keypad is in armed state
5. Panic zones can be bypassed if enabled in zone options location 101 to 164
6. New User Property -- Allow or disallow a user from bypassing zones (Option 10)

Partitions	➔	1 2 3 4 5 6 7 8
Status	➔	r n E S A ! n r

## 15. Appendix

### Extra Contact ID Zone Reporting Codes

When these values are entered into locations 304 to 307 the zone that now has this new value will report the Contact ID code that is associated with it.

Value	CID	Description
01	100	Medical Zone
02	101	Personal Emergency Zone
03	102	Fail to report in Zone
04	110	Fire Zone
05	111	Smoke Zone
06	112	Combustion Zone
07	113	Water flow Zone
08	114	Heat Zone
09	115	Pull Station Zone
0A	116	Duct Zone
0B	117	Flame Zone
0C	118	Near Alarm Zone
0D	120	Panic Zone
0E	121	Duress User
0F	122	Silent Zone
10	123	Audible Zone
11	124	Duress – Access granted Zone
12	125	Duress – Egress granted Zone
13	130	Burglary Zone
14	131	Perimeter Zone
15	132	Interior Zone
16	133	24 Hour (Safe) Zone
17	134	Entry/Exit Zone
18	135	Day/night Zone
19	136	Outdoor Zone
1A	137	Tamper Zone
1B	138	Near alarm Zone
1C	139	Intrusion Verifier Zone
1D	140	General Alarm Zone
1E	141	Polling loop open Zone
1F	142	Polling loop short Zone
20	143	Expansion module failure Zone
21	144	Sensor tamper Zone
22	145	Expansion module tamper Zone
23	146	Silent Burglary Zone
24	147	Sensor Supervision Failure Zone
25	150	24 Hour Non-Burglary Zone
26	151	Gas detected Zone
27	152	Refrigeration Zone
28	153	Loss of heat Zone
29	154	Water Leakage Zone
2A	155	Foil Break Zone
2B	156	Day Trouble Zone
2C	157	Low bottled gas level Zone

Value	CID	Description
3C	303	RAM Checksum bad Zone
3D	304	ROM checksum bad Zone
3E	305	System reset Zone
3F	306	Panel programming changed Zone
40	307	Self- test failure Zone
41	308	System shutdown Zone
42	309	Battery test failure Zone
43	310	Ground fault Zone
44	311	Battery Missing/Dead Zone
45	312	Power Supply Overcurrent Zone
46	313	Engineer Reset User
47	320	Sounder/Relay Zone
48	321	Bell 1 Zone
49	322	Bell 2 Zone
4A	323	Alarm relay Zone
4B	324	Trouble relay Zone
4C	325	Reversing relay Zone
4D	326	Notification Appliance Ckt. # 3 Zone
4E	327	Notification Appliance Ckt. #4 Zone
4F	330	System Peripheral trouble Zone
50	331	Polling loop open Zone
51	332	Polling loop short Zone
52	333	Expansion module failure Zone
53	334	Repeater failure Zone
54	335	Local printer out of paper Zone
55	336	Local printer failure Zone
56	337	Exp. Module DC Loss Zone
57	338	Exp. Module Low Batt. Zone
58	339	Exp. Module Reset Zone
59	341	Exp. Module Tamper Zone
5A	342	Exp. Module AC Loss Zone
5B	343	Exp. Module self-test fail Zone
5C	344	RF Receiver Jam Detect Zone
5D	350	Communication trouble Zone
5E	351	Telco 1 fault Zone
5F	352	Telco 2 fault Zone
60	353	Long Range Radio xmitter fault Zone
61	354	Failure to communicate event Zone
62	355	Loss of Radio supervision Zone
63	356	Loss of central polling Zone
64	357	Long Range Radio VSWR problem Zone
65	370	Protection loop Zone
66	371	Protection loop open Zone
67	372	Protection loop short Zone



Value	CID	Description
2D	158	High temp Zone
2E	159	Low temp Zone
2F	161	Loss of air flow Zone
30	162	Carbon Monoxide detected Zone
31	163	Tank level Zone
32	200	Fire Supervisory Zone
33	201	Low water pressure Zone
34	202	Low CO2 Zone
35	203	Gate valve sensor Zone
36	204	Low water level Zone
37	205	Pump activated Zone
38	206	Pump failure Zone
39	300	System Trouble Zone
3A	301	AC Loss Zone
3B	302	Low system battery Zone
77	389	Sensor self-test failure Zone
78	391	Sensor Watch trouble Zone
79	392	Drift Compensation Error Zone
7A	393	Maintenance Alert Zone
7B	400	Open/Close User
7C	401	O/C by user User
7D	402	Group O/C User
7E	403	Automatic O/C User
7F	404	Late to O/C (Note: use 453, 454 instead ) User
80	405	Deferred O/C (Obsolete-donot use )
81	406	Cancel User
82	407	Remote arm/disarm User
83	408	Quick arm User
84	409	Keyswitch O/C User
85	441	Armed STAY User
86	442	Keyswitch Armed STAY User
87	450	Exception O/C User
88	451	Early O/C User
89	452	Late O/C User
8A	453	Failed to Open User
8B	454	Failed to Close User
8C	455	Auto-arm Failed User
8D	456	Partial Arm User
8E	457	Exit Error (user) User
8F	458	User on Premises User
90	459	Recent Close User
91	461	Wrong Code Entry Zone
92	462	Legal Code Entry User
93	463	Re-arm after Alarm User
94	464	Auto-arm Time Extended User

Value	CID	Description
68	373	Fire trouble Zone
69	374	Exit error alarm (zone) Zone
6A	375	Panic zone trouble Zone
6B	376	Hold-up zone trouble Zone
6C	377	Swinger Trouble Zone
6D	378	Cross-zone Trouble Zone
6E	380	Sensor trouble Zone
6F	381	Loss of supervision - RF Zone
70	382	Loss of supervision - RPM Zone
71	383	Sensor tamper Zone
72	384	RF low battery Zone
73	385	Smoke detector Hi sensitivity Zone
74	386	Smoke detector Low sensitivity Zone
75	387	Intrusion detector Hi sensitivity Zone
76	388	Intrusion detector low sensitivity Zone
AD	521	Bell 1 disable Zone
AE	522	Bell 2 disable Zone
AF	523	Alarm relay disable Zone
B0	524	Trouble relay disable Zone
B1	525	Reversing relay disable Zone
B2	526	Notification Appliance Ckt. # 3 disable Zone
B3	527	Notification Appliance Ckt. # 4 disable Zone
B4	531	Module Added Zone
B5	532	Module Removed Zone
B6	551	Dialer disabled Zone
B7	552	Radio transmitter disabled Zone
B8	553	Remote Upload/Download disabled Zone
B9	570	Zone/Sensor bypass Zone
BA	571	Fire bypass Zone
BB	572	24 Hour zone bypass Zone
BC	573	Burg. Bypass Zone
BD	574	Group bypass User
BE	575	Swinger bypass Zone
BF	576	Access zone shunt Zone
C0	577	Access point bypass Zone
C1	601	Manual trigger test report Zone
C2	602	Periodic test report Zone
C3	603	Periodic RF transmission Zone
C4	604	Fire test User
C5	605	Status report to follow Zone
C6	606	Listen- in to follow Zone
C7	607	Walk test mode User
C8	608	Periodic test - System Trouble Present Zone
C9	609	Video Xmitter active Zone
CA	611	Point tested OK Zone

Value	CID	Description
95	465	Panic Alarm Reset Zone
96	466	Service On/Off Premises User
97	411	Callback request made User
98	412	Successful download/access User
99	413	Unsuccessful access User
9A	414	System shutdown command received User
9B	415	Dialer shutdown command received User
9C	416	Successful Upload Zone
9D	421	Access denied User
9E	422	Access report by user User
9F	423	Forced Access Zone
A0	424	Egress Denied User
A1	425	Egress Granted User
A2	426	Access Door propped open Zone
A3	427	Access point Door Status Monitor trouble Zone
A4	428	Access point Request To Exit trouble Zone
A5	429	Access program mode entry User
A6	430	Access program mode exit User
A7	431	Access threat level change User
A8	432	Access relay/trigger fail Zone
A9	433	Access RTE shunt Zone
AA	434	Access DSM shunt Zone
AB	501	Access reader disable Zone
AC	520	Sounder/Relay Disable Zone

Value	CID	Description
CB	612	Point not tested Zone
CC	613	Intrusion Zone Walk Tested Zone
CD	614	Fire Zone Walk Tested Zone
CE	615	Panic Zone Walk Tested Zone
CF	616	Service Request Zone
D0	621	Event Log reset Zone
D1	622	Event Log 50% full Zone
D2	623	Event Log 90% full Zone
D3	624	Event Log overflow Zone
D4	625	Time/Date reset User
D5	626	Time/Date inaccurate Zone
D6	627	Program mode entry Zone
D7	628	Program mode exit Zone
D8	629	32 Hour Event log marker Zone
D9	630	Schedule change Zone
DA	631	Exception schedule change Zone
DB	632	Access schedule change Zone
DC	641	Senior Watch Trouble Zone
DD	642	Latch-key Supervision User
DE	651	Reserved for Ademco Use Zone
DF	652	Reserved for Ademco Use User
E0	653	Reserved for Ademco Use User
E1	654	System Inactivity

## 16. Hardware Identification

The new X series PCB has a larger memory chip on board to accommodate the new features and to distinguish between the old and new "512K" will be screened onto the PCB and will have a silver warranty sticker on the processor.

**Note:** The X16 will have X16 printed on the silver warranty label.

**Figure 6: Distinguishing 512k boards from previous versions**

Silver warranty sticker only

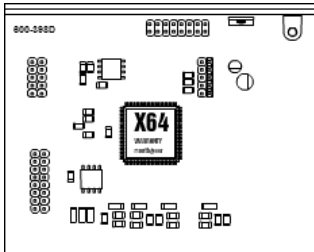

Silver warranty sticker and 512K printed

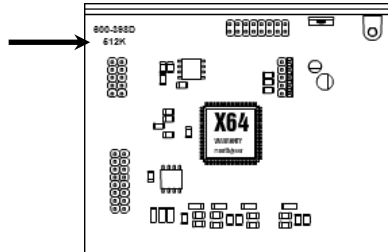

**Note:** Firmware version 2.1 cannot be loaded onto older X Series panels!

## 17. Serial Communication Jumper Settings

To select which serial communication option:

J1 open = direct download

J1 closed = serial reporting enabled

**Figure 7: Serial communication jumper location**

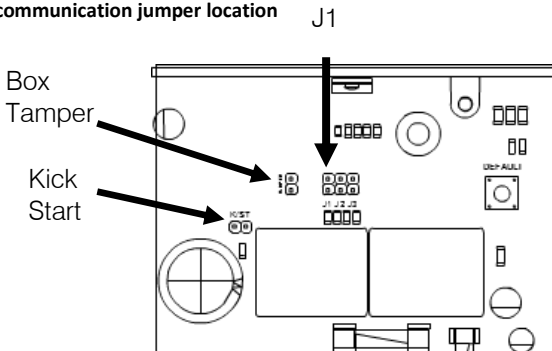

**Note:** If J1 is shorted after the system is powered on, please repower the system with J1 shorted to enable serial communication

## 18. Index

24 Hour Alarm Zone	20	locations	19
AC Fail / Restore Reporting Delay Arm	23	Locations	19
Stay	34	log <i>See</i> Event Log	
Arm/Disarm Zone	20	Mains Failure	11, 23
Auto Arm Days	36	Number of Account Code Digits	26
Auto Arm Time	36	Number of Dial Attempts	30
Auto Disarm Time	37	Number of Rings to Answer	31
Battery	24	Outdoor Instant Zone	20
Bitmapped Location	15, 18, 70	Panic/Priority Zone	20
Box Tamper	11, 23, 24, 56, 59	Partition Options	39
Contact ID	28, 29, 59, 60	Peripheral Devices	11
Cross-zone Delay Timer	22, 33	Primary Entry Delay Period	40
Cross-zoning	22, 33	Primary Entry/Exit Zone	20, 40
Damaged Keypad	13	Programmable Outputs	11, 53, 54, 56
Default Keypad Partition	40	Programming a Bitmapped Location	70
Defaulting Keypads	13	Programming Extended Locations	17, 70
Devices (Enrolling)	12	Programming Location Summary	19
Disabled Zone	20	Programming Standard Locations	16, 70
Download Code	14	Quick Arm (Explanation)	38
Download Software	14, 30	Radio Transmitter Connection	12
Dual Reporting	30, 31, 33, 56	Remote Control Receiver	11
Earth	11	Remote Control Unit	11, 20
End-of-Line Resistors	11	Remote Receiver	12, 13
Engineer Reset (Explanation)	39	Replacing a Damaged Keypad Device	13
Enrolling Keypads	12	resistors	11
Entering Program Mode	16, 70	Secondary Entry/Exit Zone	20
Entry Delay	34	Silent Zone	33
Event Log	12, 14, 20, 30	Siren	24, 33
Exit Delay	34	Siren Toot on Away Arm / Disarm (Explanation)	38
Expander Module - Installation	12	Stay Mode	34
Fire Zone	20, 25, 33	Stay Profile	34
Follower Zone	20	Stay Zone	<i>See</i> Zone
Force Arm (Explanation)	38	Swinger Shutdown	33
Global Options	25	Tamper	25
Hardware Default Switch	12	Tamper by Zone	33, 49
Installation	10	Tamper Zone	20
Installer Code	14, 26, 37	Telephone Communicator - Connecting	11
Instant Zone	20	Transformer	11
keypad bus	46	Trouble Display	19
Keypad Bus	12	Warning Zone	20
Keypad Lockout Count	25	Wiring	10, 13
Keypad Options	41	Zone	
Keypad Setup (Individual)	41	Buzz	34
Key-switch	11, 20, 38, 39	Entry/Exit	34
Lightning Protection	11	Stay	34
Location Values	15	Zone Properties	33

## 19. Cross Reference Lookup

### Arming / Disarming

Basic Setup	Location	18
	Locations	230 – 232
Advanced Setup	Locations	180 – 190

### Communications

Basic Setup	Locations	51 – 54
	Locations	61 – 68
	Locations	71 – 78
Advanced Setup	Locations	41 – 50

### Daylight Savings

Basic Setup	Locations	25 – 31
-------------	-----------	---------

### General

Basic Setup	Locations	14 – 16
	Location	23
Advanced Setup	Locations	32 – 35
	Locations	300 – 303

### Keypads

Basic Setup	Locations	20 – 22
	Locations	240 – 243
Advanced Setup	Locations	251 – 258

### No Movement

Advanced Setup	Locations	171 – 176
----------------	-----------	-----------

### Outputs

Basic Setup	Locations	380 – 386
	Location	389
	Locations	415 – 422
	Locations	458 – 498
Advanced Setup	Locations	390 – 414
	Locations	423 – 426
	Locations	428 – 434
	Locations	437 – 444
	Locations	447 – 454
	Location	457

### Partitions

Basic Setup	Locations	201 – 208
Advanced Setup	Locations	211 – 218
	Locations	221 – 228

### Reporting Codes

Basic Setup	Locations	501 – 564
	Locations	571 – 574
	Locations	581 – 588
Advanced Setup	Locations	304 – 340
	Locations	342 – 373

### Security

Basic Setup	Locations	197 – 199
-------------	-----------	-----------

### Zones

Basic Setup	Locations	1 – 8
	Locations	101 – 164
	Locations	201 – 208
Advanced Setup	Locations	11 – 13

## 20. Programming Quick Reference Guide

### Entering Program Mode

- **[#] [INSTALLER CODE] [\*]** to enter program mode.
- A long beep will confirm entry.
- The READY LED will flash.

### Programming Standard Locations

- The panel is in program mode – the READY LED is flashing.
- **[LOCATION NUMBER] [\*]**
- The READY LED is solid on, and the AWAY LED will flash.
- Either **[NEW DATA] [\*]** or **[#]** to exit.
- If data is entered, a long beep will confirm entry.
- In both instances, the READY LED will to flash and the AWAY LED will turn off.
- **[#]** to exit.
- The READY LED will stop flashing.
- The panel is now in standby mode.

### Programming Extended Locations with Strings

- Panel is in program mode – the READY LED is flashing.
- **[LOCATION NUMBER] [\*]**
- The READY LED is solid on, and the ARM and AWAY LEDs will flash.
- **[STRING] [\*]**
- The ARM and AWAY LEDs turn off, and the READY LED will flash.
- If you do not want to change data press **[#]**.
- The READY LED will continue to flash, whilst the ARM and AWAY LEDs turn off.
- **[#]** to exit.
- The READY LED will stop flashing.
- The panel is now in standby mode.

### Programming Extended Locations with Sub-locations

- Panel is in program mode – the READY LED is flashing.
- **[LOCATION NUMBER] [\*]**
- The READY LED is solid on, and the ARM and AWAY LEDs will flash.
- **[SUB-LOCATION NUMBER] [\*]**
- The READY and ARM are solid on, and AWAY is flashing.
- **[NEW DATA] [\*]**
- The READY LED is solid on, and the ARM and AWAY LEDs will flash.
- **[#]** if you do not wish to make changes.
- The READY is flashing, and the ARM and AWAY LEDs turn off.
- **[#]** to exit current location.
- The READY is flashing, and the ARM and AWAY LEDs turn off.
- **[#]** to exit.
- The READY LED will stop flashing.
- The panel is now in standby mode.

### Programming a Bitmapped Location

- Panel is in program mode – the READY LED is flashing.
- **[LOCATION NUMBER] [\*]**
- The READY LED is solid, and the AWAY LED flashes.
- **[#]** to exit current location.
- READY is flashing.
- **[#]** to exit.
- The READY LED will stop flashing.
- The panel is now in standby mode.

## 21. Trouble Display

A trouble condition is indicated by the power LED on the keypad flashing.

To view what the trouble condition, hold the 7 key for 3 seconds.

To cancel the trouble condition, once it has been rectified, go into viewing the trouble condition and then press #.

No.	Trouble	Description
1	AC Fail	16V AC has gone missing
2	Communication Failed	The alarm has tried to communicate with the reaction company and failed
3	Phone line tamper	The system has detected that the phone line is no longer connected
4	Siren tamper	The system has detected that the siren is no longer connected
5	Battery Trouble	The battery has been removed or is faulty
6	AUX 12V trouble	The fuse is faulty or a device is causing a power issue
7	Engineer reset	The installer code must be entered before the system may be armed
8	Box Trouble	The box tamper has been violated
9	Bus device tamper	A device connected to the keypad bus has been tampered
10	Bus device communication	A device connected to the keypad bus has lost communication with the system
11	Bus device power	A device connected to the keypad bus has lost power
12	Wireless detector battery low	A wireless detector's battery is low and must be replaced
13	Wireless detector supervision failure	Communication to a wireless detector has gone missing
14	Wireless receiver jam	Wireless receiver has detected a signal that is causing it to lose communication with all devices
15	Wireless detector RSSI trouble	The signal being received from a detector is too low
16	Zone Tamper	A zone has experienced a tamper



## Warranty

Inhep Electronics Holdings (Pty) Ltd guarantees all IDS Control Panels against defective parts and workmanship for 24 months from date of purchase. Inhep Electronics Holdings shall, at its option, repair or replace the defective equipment upon the return of such equipment to any Inhep Electronics Holdings branch. This warranty applies ONLY to defects in components and workmanship and NOT to damage due to causes beyond the control of Inhep Electronics Holdings, such as incorrect voltage, lightning damage, mechanical shock, water damage, fire damage, or damage arising out of abuse and improper application of the equipment.

**NOTE:** Wherever possible, return only the PCB to Inhep Electronics Holdings Service Centres.  
DO NOT return the metal enclosure.

The X-Series Products are a product of IDS (Inhep Digital Security)  
and is manufactured by  
Inhep Electronics Holdings (Pty) Ltd

### WARNING

For safety reasons, only connect equipment with a telecommunications compliance label. This includes customer equipment previously labeled permitted or certified.

This is a professional product, and due to the nature of the product, should only be installed by an accredited professional Alarm Installer.

**Help Desk Number: 0860 705137\***

\*Please note that this is NOT a toll free number

