

User Manual

IPM-01, PDU management software

MTS switched PDU

MT monitored PDU



Designed and manufactured by Austin Hughes

Legal Information

First English printing, October 2002

Information in this document has been carefully checked for accuracy; however, no guarantee is given to the correctness of the contents. The information in this document is subject to change without notice. We are not liable for any injury or loss that results from the use of this equipment.

Safety Instructions

Please read all of these instructions carefully before you use the device. Save this manual for future reference.

- Unplug equipment before cleaning. Don't use liquid or spray detergent; use a moist cloth.
- Keep equipment away from excessive humidity and heat. Preferably, keep it in an air-conditioned environment with temperatures not exceeding 40° Celsius (104° Fahrenheit).
- When installing, place the equipment on a sturdy, level surface to prevent it from accidentally falling and causing damage to other equipment or injury to persons nearby.
- When the equipment is in an open position, do not cover, block or in any way obstruct the gap between it and the power supply. Proper air convection is necessary to keep it from overheating.
- Arrange the equipment's power cord in such a way that others won't trip or fall over it.
- If you are using a power cord that didn't ship with the equipment, ensure that it is rated for the voltage and current labelled on the equipment's electrical ratings label. The voltage rating on the cord should be higher than the one listed on the equipment's ratings label.
- Observe all precautions and warnings attached to the equipment.
- If you don't intend on using the equipment for a long time, disconnect it from the power outlet to prevent being damaged by transient over-voltage.
- Keep all liquids away from the equipment to minimize the risk of accidental spillage. Liquid spilled on to the power supply or on other hardware may cause damage, fire or electrical shock.
- Only qualified service personnel should open the chassis. Opening it yourself could damage the equipment and invalidate its warranty.
- If any part of the equipment becomes damaged or stops functioning, have it checked by qualified service personnel.

What the warranty does not cover

- Any product, on which the serial number has been defaced, modified or removed.
- Damage, deterioration or malfunction resulting from:
 - Accident, misuse, neglect, fire, water, lightning, or other acts of nature, unauthorized product modification, or failure to follow instructions supplied with the product.
 - Repair or attempted repair by anyone not authorized by us.
 - Any damage of the product due to shipment.
 - Removal or installation of the product.
 - Causes external to the product, such as electric power fluctuation or failure.
 - Use of supplies or parts not meeting our specifications.
 - Normal wear and tear.
 - Any other causes which does not relate to a product defect.
- Removal, installation, and set-up service charges.

Regulatory Notices Federal Communications Commission (FCC)

This equipment has been tested and found to comply with the limits for a Class B digital device, pursuant to Part 15 of the FCC rules. These limits are designed to provide reasonable protection against harmful interference in a residential installation.

Any changes or modifications made to this equipment may void the user's authority to operate this equipment. This equipment generates, uses, and can radiate radio frequency energy and, if not installed and used in accordance with the instructions, may cause harmful interference to radio communications.

However, there is no guarantee that interference will not occur in a particular installation. If this equipment does cause harmful interference to radio or television reception, which can be determined by turning the equipment off and on, the user is encouraged to try to correct the interference by one or more of the following measures:

- Re-position or relocate the receiving antenna.
- Increase the separation between the equipment and receiver.
- Connect the equipment into an outlet on a circuit different from that to which the receiver is connected.

The company reserves the right to modify product specifications without prior notice and assumes no responsibility for any error which may appear in this publication.

All brand names, logo and registered trademarks are properties of their respective owners.

Copyright 2011 Austin Hughes Electronics Ltd. All rights reserved.

Unpacking

The equipment comes with the standard parts shown on the package contents. Check and make sure they are included and in good condition. If anything is missing, or damage, contact the supplier immediately.

Package contents

(1) Vertical MTS / MT PDU x 1

- **VMS** mounting screw, set of 2 or 3



- **VMB** mounting bracket set

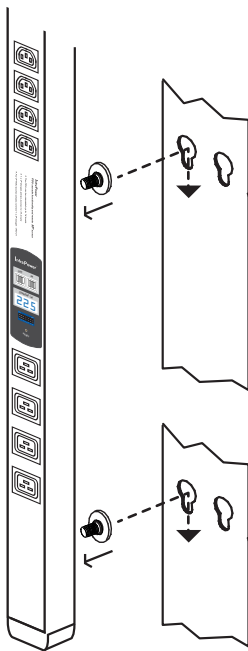
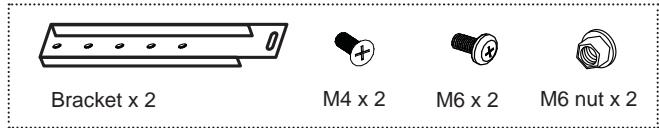

OR

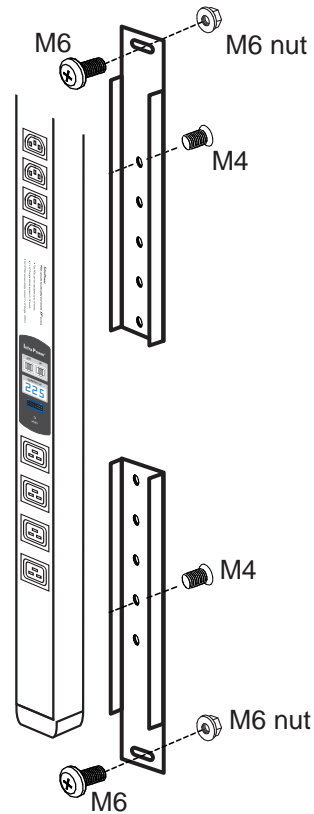

(2) Rackmount MTS / MT PDU x 1



All electrical power and power control wiring must be installed by a qualified electrician and comply with local and national regulations.

Power ON

- Connect the PDU into an appropriately rated receptacle
- When the PDU is power on, the LED display will light up. That means all outlets are activated
- Keep the equipments in the power off position until it is plugged into the PDU



Don't exceed the outlet, branch or phase limitations

Content

Over IP connection via IP dongle

Part I. Setup and Connection P. 1

- < 1.1 > PDU meter setting & cascade
- < 1.2 > IP dongle installation & connection
- < 1.3 > Temp. & Humidity connection & specification

Part II. IP Configuration and Software P. 7

- < 2.1 > IP dongle configuration
- < 2.2 > InfraPower Manager - IPM-01
FREE PDU management software

Part III. Data Export P. 23

Part IV. FAQ P. 27

- < 4.1 > InfraPower Manager - IPM-01
- < 4.2 > IP dongle
- < 4.3 > Meter for MTS & MT PDU
- < 4.4 > Others

Part V. Troubleshooting P. 30

- < 5.1 > PDU disconnection
- < 5.2 > Replacement, removal or addition for PDU & IP dongle

Part I. Setup and Connection

< 1.1 > PDU meter setting & cascade

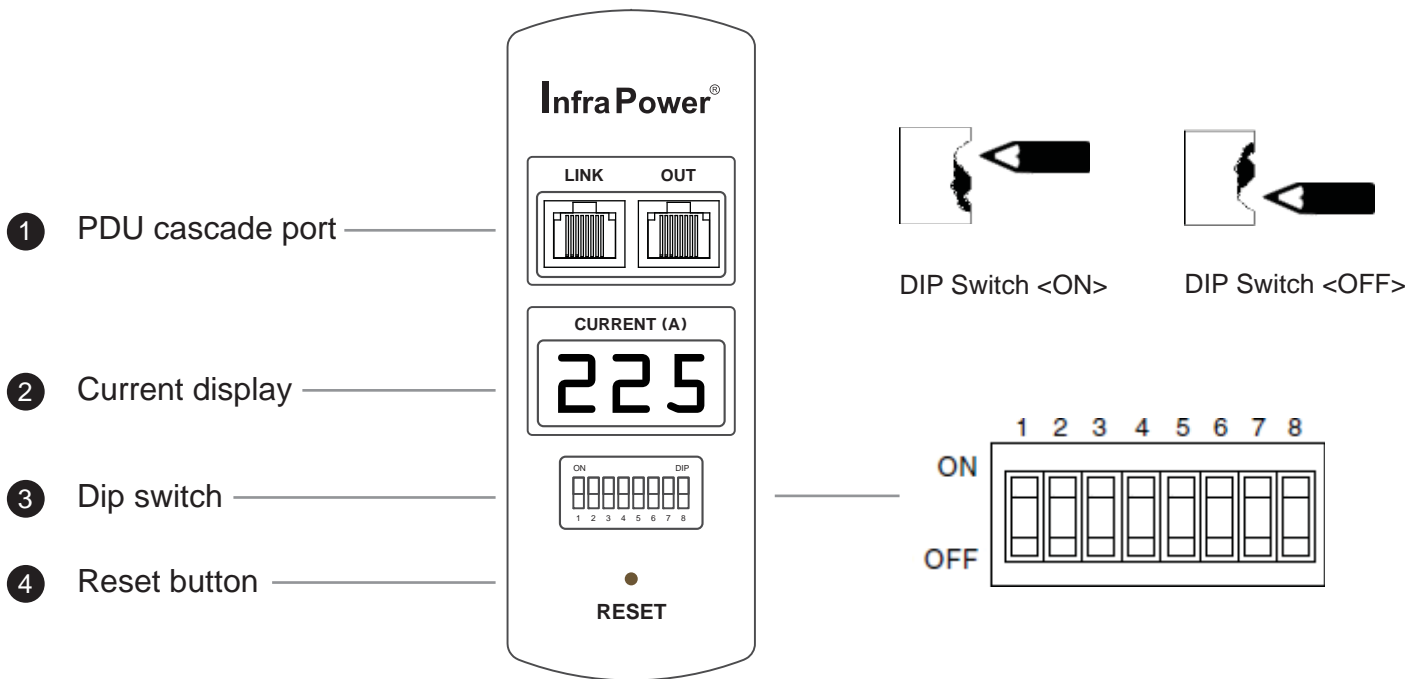

■ For rackmount PDU, ② ③ ④ on the front panel left , ① on the rear panel

Cascaded PDUs setting

Using the **dip switch no. 1, 2, 3, 4 & 8** to setup each PDU level as below :

Cascaded PDUs	Dip switch no.				
	1	2	3	4	8
1st level PDU	On	On	On	On	Off
2nd level PDU	Off	On	On	On	Off
3rd level PDU	On	Off	On	On	Off
4th level PDU	Off	Off	On	On	Off
5th level PDU	On	On	Off	On	Off
6th level PDU	Off	On	Off	On	Off
7th level PDU	On	Off	Off	On	Off
8th level PDU	Off	Off	Off	On	Off
9th level PDU	On	On	On	Off	Off
10th level PDU	Off	On	On	Off	Off
11th level PDU	On	Off	On	Off	Off
12th level PDU	Off	Off	On	Off	Off
13th level PDU	On	On	Off	Off	Off
14th level PDU	Off	On	Off	Off	Off
15th level PDU	On	Off	Off	Off	Off
16th level PDU	Off	Off	Off	Off	Off

< 1.1 > PDU meter setting & cascade

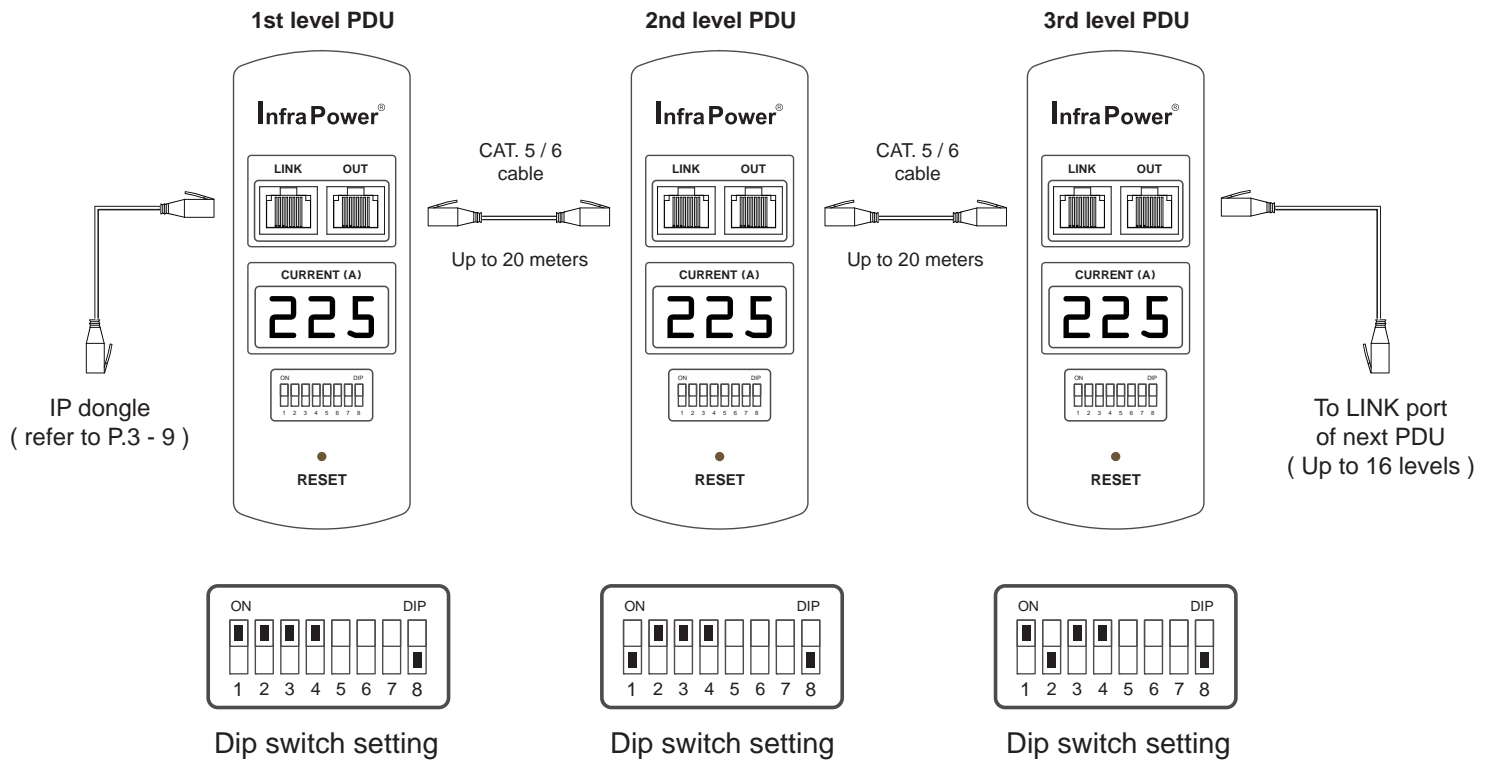

- The PDU can be cascaded up to 16 levels
- For IP PDU access simply connect 1 x IP dongle - IPD-01
- 1 x IP dongle allows access to 16 levels

Meter display setting

Using the **dip switch no. 5 & 7** to setup each PDU meter display as below :

Current display	Dip switch no.	
	5	7
Circuit A + Circuit B	Off	Off
Circuit A only	On	Off
Circuit B only	On	On

Audio alarm

Using the **dip switch no. 6** to setup each PDU audio alarm as below :

	Dip switch 6
Enable	Off
Disable	On

< 1.2 > IP dongle installation & connection

To remote PDU over IP, users can order IP dongle :

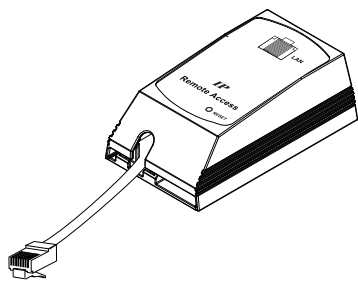

IPD-01 IP dongle for vertical PDU

Vertical IP dongle installation steps :

- slide the IP dongle on the plate above the meter
- plug the RJ-45 connector of IP dongle into the LINK port of the 1st level PDU meter
- use the CAT. 5 / 6 cable to connect IP dongle to network device



To LAN port

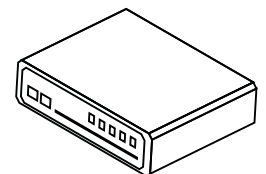
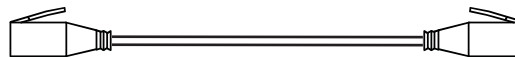

Customer's network device (router or hub)

■ Please refer dip switch setting on P.1 - 2 for different level PDUs

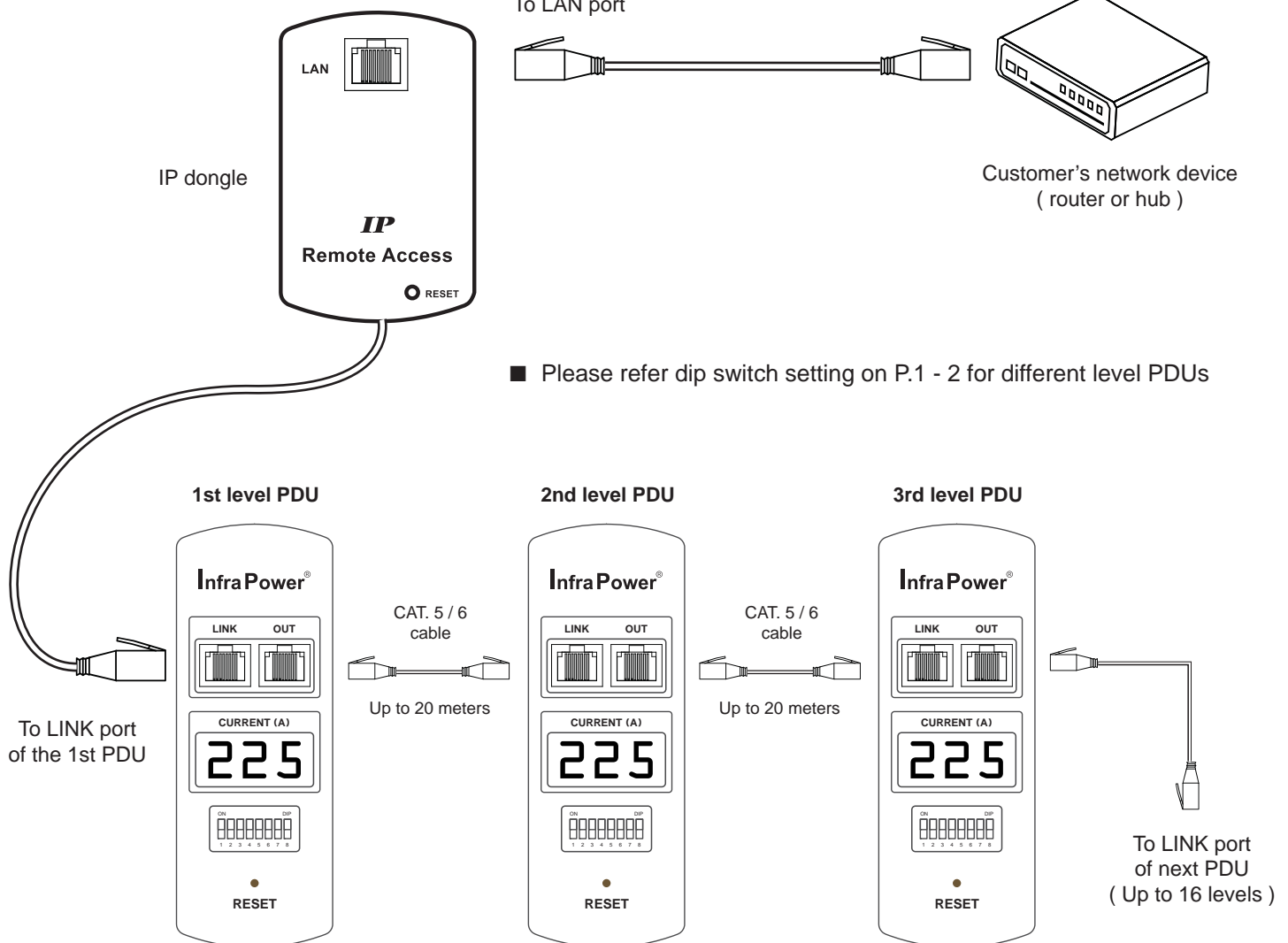

< 1.2 > IP dongle installation & connection

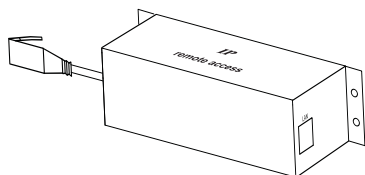

IPD-H01 IP dongle for rackmount PDU

Horizontal IP dongle installation steps :

- fix the IP dongle on the rear side of rackmount PDU with 4 screws
- plug the RJ-45 connector of IP dongle into the LINK port of the 1st level PDU meter
- use the CAT. 5 / 6 cable to connect IP dongle to network device

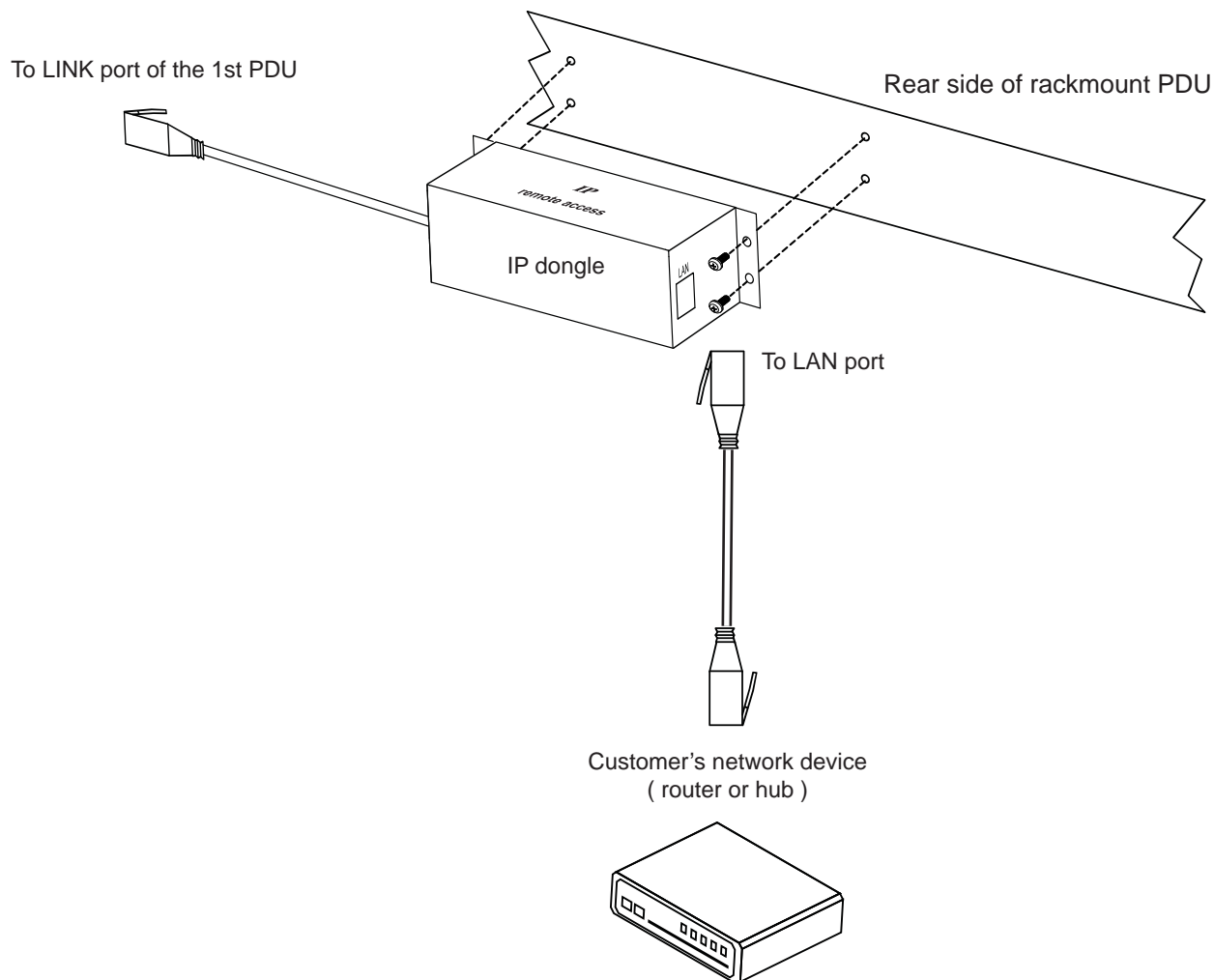

< 1.3 > Temp. & Humidity connection & specification

MT / MTS meter provides 1 sensor port for Temp. & Humidity monitoring. The user can see the Temp. / Humidity reading not only from the local meter display but also from remote management software.

- low profile design with magnetic base for easy affixing to the rack cabinet
- Plug n Play
- sensor with 2M or 4M cord



Temp. & Humid. Sensor

Model :

IG - TH01 - 2M (2M cord)

IG - TH01 - 4M (4M cord)

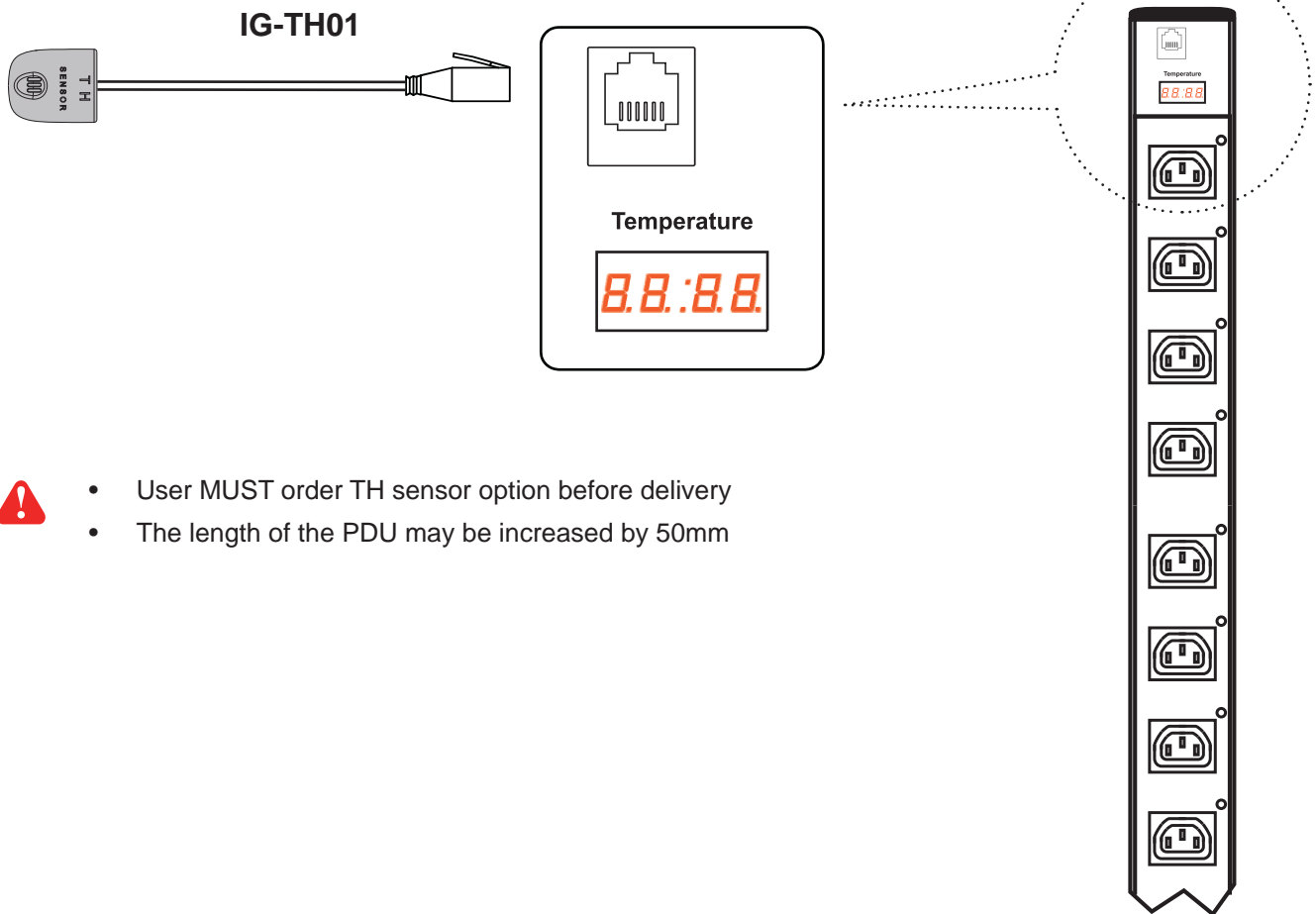

- User MUST order TH sensor option before delivery
- The length of the PDU may be increased by 50mm

< 1.3 > Temp. & Humidity Sensor Connection & Specification

		Temp. & Humid. Sensor
Part no.		IG - TH01
Temperature Sensitivity	Range	0 to 80°C (32 to 176°F)
	Accuracy	±1.0°C typical (±2°F)
	Resolution	0.1°C (0.2°F)
	Response Time	5 to 30 sec
Relative Humidity Sensitivity	Range	0 to 100% R.H
	Accuracy	0 to 100, ±8.0% R.H 20 to 80, ±4.5% R.H.
	Resolution	1% R.H.
	Response Time	8 sec
Power Requirement	Voltage	12VDC, powered by sensor port
	Current Consumption	20mA
	Power consumption	0.24 Watt
	Power on indicator	Red LED
Housing	Chassis & Cover	plastic
	Color	Dark gray
	Installation	Magnetic base for unrestricted installation
Cable	Cable Length	TH sensor w/ 2m cable (standard) TH sensor w/ 4m cable (option)
	Cable Specification	4-wired 3.5mm to RJ11
	Cable Color	Black
Environmental	Operating	0 to 80°C Degree
	Storage	-5 to 80°C Degree
	Humidity	0~100%, non-condensing
Dimensions	Product	30L x 25Wx 18H mm
Weight	Net	10g
Compatibility	InfraPower	W / WS / Wi / WSi series PDU
	InfraSolution	X-2000 series
	InfraGuard	Cabinet sensor system

Part II. IP Configuration and Software

< 2.1 > IP dongle configuration

After the completion of IP dongle connection, please take the following steps to configure the IP dongle :

1. Prepare a notebook computer to download the IP setup utilities from the link :
<http://www.austin-hughes.com/support/utilities/infrapower/IPdongleSetup.msi>
2. Double click the IPDongleSetup.msi and follow the instruction to complete the installation.
3. Go to each first level PDU with the notebook computer & a piece of CAT. 5 / 6 cable to configure the IP dongle by IP setup utilities as below. Please take the procedure for all IP dongles **ONE BY ONE**.

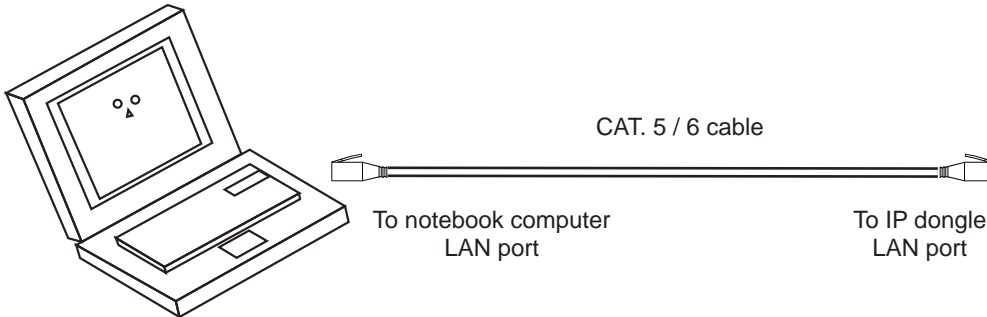

 Reconnect the IP dongle with the network device (router or hub), after finish IP dongle configuration.

IP dongle on 1st level PDU



Ensure the PDU in power ON status

The screenshot shows the 'IP setup utilities for IP Dongle (Ver. Q411V1)' application window. The window title is 'IP setup utilities for IP Dongle (Ver. Q411V1)'. The main title is 'InfraPower® Intelligent Remote Power Management'. The window is divided into two sections: 'IP Dongle list' and 'Configuration'. The 'IP Dongle list' section has a 'Device MAC address' field with the value '00:0D:5D:05:BC:1A' and a 'Scan' button. The 'Configuration' section has several fields: 'Name' (empty), 'Location' (Rack_001), 'Password' (empty), 'New password' (empty), 'Confirm new password' (empty), 'IP address' (192.168.0.1), 'Subnet mask' (255.255.255.0), and 'Gateway' (192.168.0.254). There are 'Save' and 'Close' buttons at the bottom.

 Write down the new IP address & password for < Setup > purpose, refer to P.13

4. Click **Scan** to search the connected IP dongles
5. Enter the device name in the name field (min. 4 char. / max. 16 char.). **The default is Name.**
6. Enter the location in the location field (min. 4 char. / max. 16 char.). **The default is Rack_001.**
7. Enter the password in the password field for authentication (min. 8 char. / max. 16 char.). **The default is 0000000.**
8. Enter the new password in the new password field (min. 8 char. / max. 16 char.).
9. Re-enter the new password in the Confirm new password field.
10. Change the desired IP address / Subnet mask / Gateway, then click **Save** to confirm the setting to IP dongle.
11. The default IP address is as below:
IP address : 192.168.0.1
Subnet mask : 255.255.255.0
Gateway : 192.168.0.254

< 2.2 > InfraPower Manager - IPM-01, FREE PDU management software

InfraPower Manager, IPM-01, is a FREE **PDU** management software to enhance the features and benefits of the MTS switched and MT monitored PDUs by providing a centralized and remote management platform, and total reporting with detailed logs & event occurrences.

InfraPower Manager IPM-01 can support max. 5 concurrent login users and manage multi- IP dongles max. 15, hence the concurrent login users can access & remote PDUs max. 240 (15 IP dongles x 16 level PDUs).



Step 1. Software download

Prepare a management PC to download the free InfraPower Manager - IPM-01

from the link <http://www.austin-hughes.com/support/software/infrapower/IPM-01.msi>

Supported OS platform list :

- MS Windows XP Professional with SP3 (32bit only)
- MS Windows 7 Professional with SP1
- MS Windows 7 Ultimate with SP1
- MS Windows Server 2003 R2 Standard Edition with SP2
- MS Windows Server 2008 Standard Edition SP2
- MS Windows Server 2008 R2 Standard Edition SP1



Ensure the user logs in the management PC as a member of “Administrators” Group before IPM-01 Installation and execution.

Step 2. System setup

Initial system setup on :

- < User >
- < Setup >
- < Alarm >
- < Scan >
- < Refresh >
- < Temp. >
- < Backup >
- < SNMP >
- < Sys log >
- < Past Sys log >

Step 3. Usage & operation

- < Status >
- < Details >
- < Sensor >
- < PDU log >
- < Event >
- < Past log >

Step 1. Software download

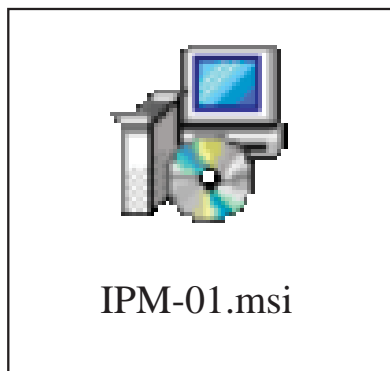

Double click the IPM-01.msi and follow the instruction to complete the installation.

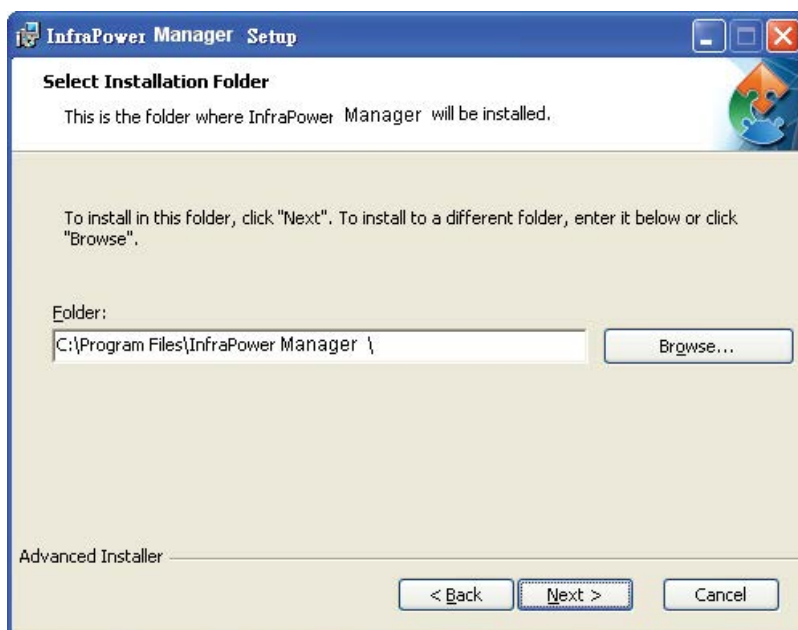

Step 1. Software download

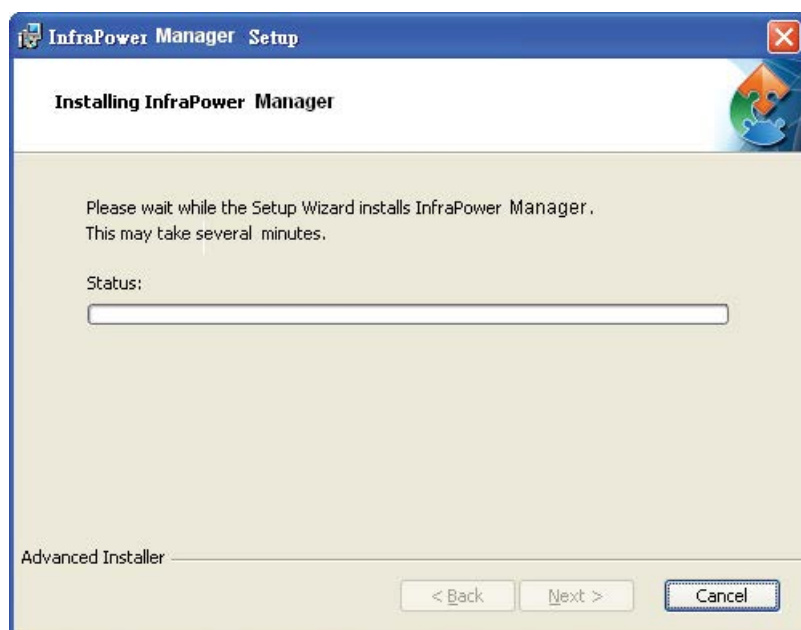
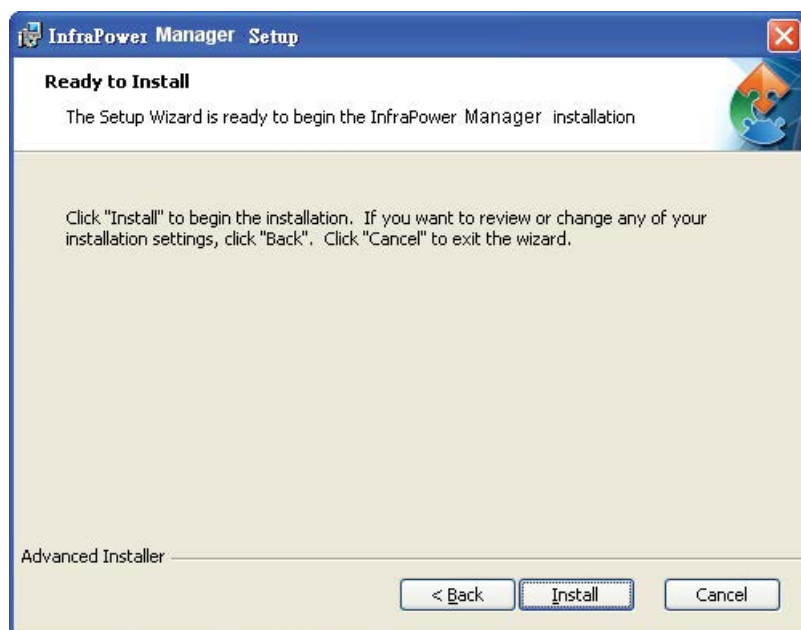

Step 1. Software download

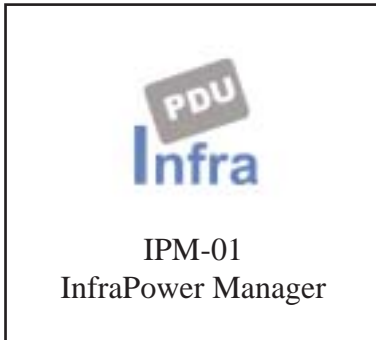

Double click the **InfraPower Manager - IPM-01** and follow the instruction to complete start-up setting.

 **For MS Windows 7 and MS Windows server 2008,**

it requires to run a program with administrator rights before execution:

- Right click **InfraPower Manager - IPM-01** , and then select **Properties**.
- Click the **Compatibility** tab.
- Tick the box **Run this program as an administrator**, and then click OK.

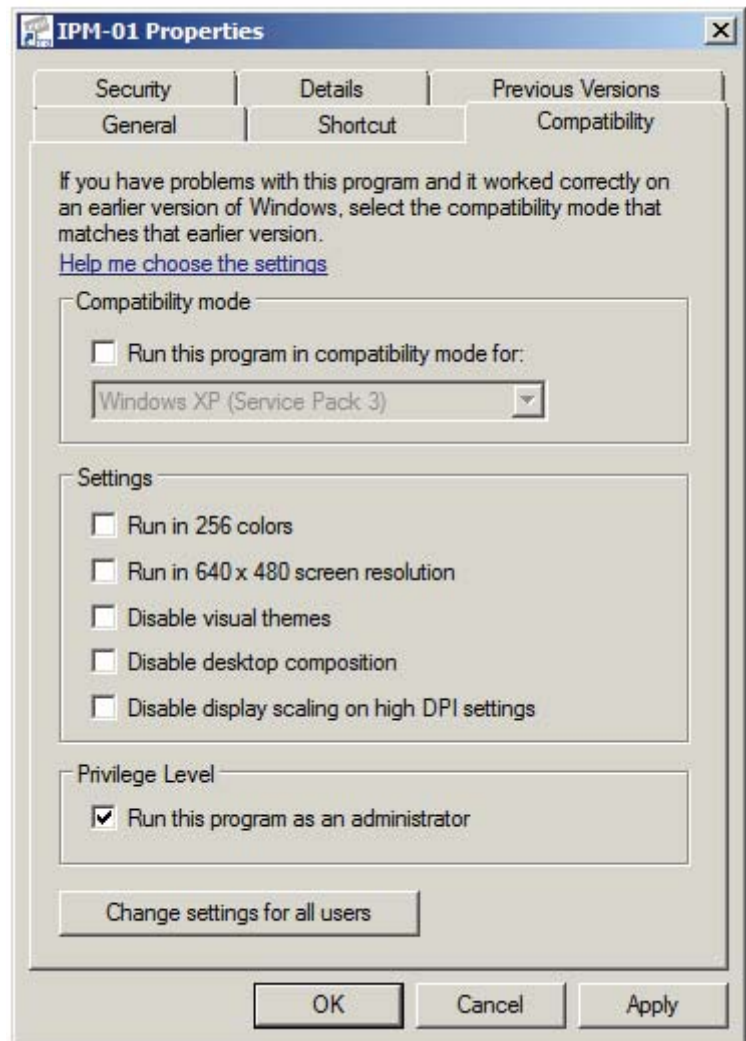
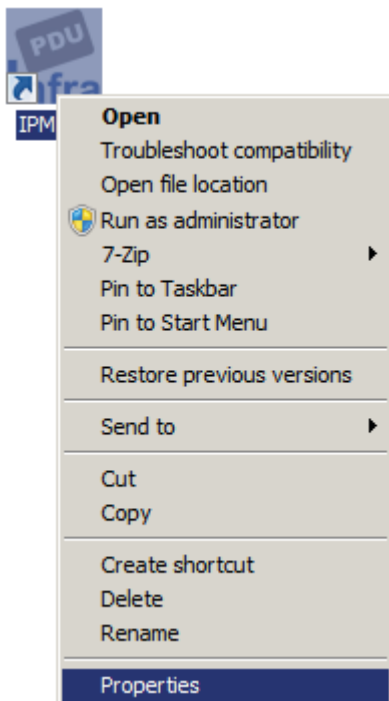

Step 1. Software Download

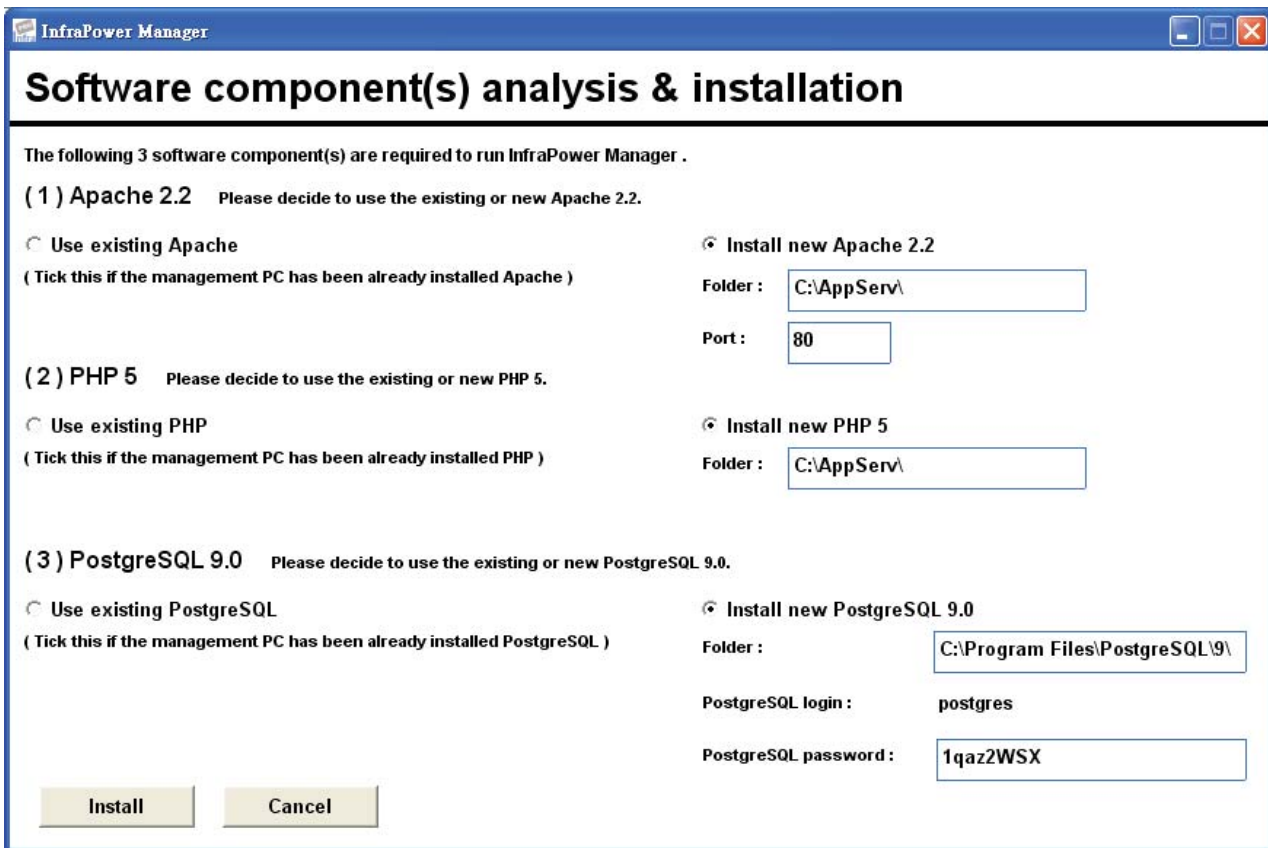

Completed



PostgreSQL password can be changed by user.

The password of PostgreSQL must contain at least three of the following four character groups:

- English uppercase characters (A through Z)
- English lowercase characters (a through z)
- Numerals (0 through 9)
- Non-alphabetic characters (such as !, \$, #, %)

Step 2. System setup

Users can follow below step 1 - 3 to access the management PC and InfraPower Manager IPM-01

System authentication

User name

Password

Step 1. Open Internet Explorer (I.E.), version 7.0 or above

Step 2. Enter the IP address of management PC into the address bar
(If fail to access, please ask MIS to check the service port of the management PC)

Step 3. Enter the user name (the default is admin)
Enter the password (the default is 00000000)

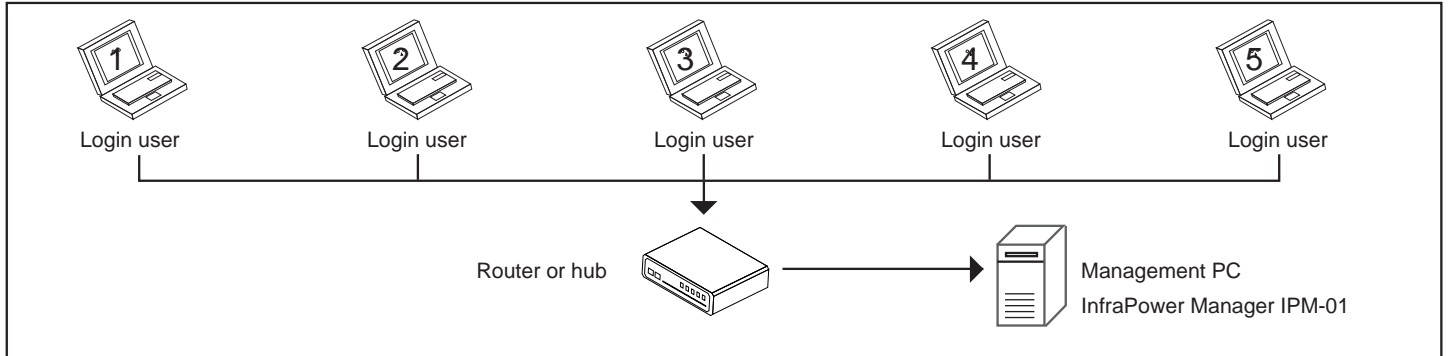

 Only Administrator is authorised to access < User >, < Setup >, < Alarm >, < Scan >, < Refresh >, < Temp. >, < Backup > & < SNMP > for initial system setup

In < **User** > page, the administrator can create max. 5 concurrent login users and set the user name & password. After this, all users can take the three steps above to access IPM-01.

User setup

Activate: Administrator: User login password: Confirm password:

• Only administrator can access

• Only administrator can set and change all users' password

• Min. 4 char, and max. 16 char, for user name.

• Min. 8 char, and max. 16 char, for user login password.

• If there is any change of user name, system will automatically delete an existing operator and create a new one, a new user login password is required.

Operator 01:

Operator 02:

Operator 03:

Operator 04:



Step 2. System setup

In < **Setup** > page, the administrator can activate the IP dongle group & set the group command password.

IP dongle groups 01 02 03 04 05 06 07 08 09 10 11 12 13 14 15

Initially, please setup the IP dongle one by one.

IP dongle group 01 : Activate Deactivate

- DO NOT activate the group if there is no any IP dongle and PDU connection.
- Each IP dongle group consist of one IP dongle and max. 16 PDU.

01 IP dongle setting

IP dongle address:

IP dongle password:

- If the administrator wants to change IP dongle address and password, two steps are requested.
- **Firstly**, enter the IP Setup utility to make the change. (ref. to User Manual page 5)
- **Secondly**, return to this page to make the same change on IP address and password.

01 IP dongle group

Command password : Enable Disable

Command password:

New password:

Confirm new password:

- Default command password is 00000000.
- Administrator needs to set command password for IP dongle groups one by one.
- Command password requested for any PDU configuration and control.
- Administrator can set different command password for different IP dongle group or all IP dongle groups share the same password. .



Step 2. System setup

< Alarm >

Alarm email server setting

Alarm email: Enable Disable

SMTP server:

SMTP port:

POP3 server:

POP3 port:

User email:

User name:

Password:

Alarm interval: (Max. 60 minutes)

* This alarm setting is for all IP dongle PDU groups.

Alarm email to

Email address:



Step 2. System setup

< Scan >

IP dongle groups auto scan

Scan rate : (Min. 5 secs, Max. 60 secs)

- Auto scan rate on the page.



< Refresh >

Auto data refresh

Refresh rate : (Min. 10 secs, Max. 60 secs)

- Auto data refresh rate on the & pages.



< Temp. >

Temperature unit

Unit: °C °F



< Backup >

Data backup setting

Daily backup : Enable Disable

Backup to :
Example : C:\Program Files\

- Daily backup proceeded at 00:00 for last 24 hours data.
- The backup data for saved in text file format.
- Folder will be automatically created under the path you entered.



< SNMP >

SNMP server setting

SNMP : Enable Disable

IP address :

Port :

Community :

- The SNMP server setting allows you to enable or disable SNMP communication between IPM-01 and SNMP manager .
- IPM-01 SNMP server must be enabled for this feature to work.
- Download the MIB file to assist you in configuring SNMP manager to retrieve data.



Step 2. System setup

< **Sys log** > provides last 5000 events in < User >, < Setup >, < Alarm >, < Scan >, < Refresh >, < Temp. >, < Backup > & < SNMP >.

First / Previous 1 2 3 4 5 6 7 8 9 10 Next / Last				Last 5000 log records.
Date (YYYY / MM / DD)	Time	Event	Description	
2012 / 02 / 14	16 : 10 : 25	Setup	[admin] : Change IP dongle 01 address or password	
2012 / 02 / 14	16 : 09 : 25	Setup	[admin] : Deactivate IP dongle group 02	
2012 / 02 / 14	16 : 08 : 25	Setup	[admin] : Deactivate IP dongle group 03	
2012 / 02 / 14	16 : 07 : 25	Setup	[admin] : Deactivate IP dongle group 04	

The types of system event

-User	(1) Add / Delete operator	- Scan	(1) Change scan mode time rate
	(2) Change user login password	- Refresh	(1) Change refresh mode time rate
- Setup	(1) Activate / Deactivate IP dongle group [No.]	- Temp.	(1) Change temp. unit - Celsius / Fahrenheit
	(2) Change IP dongle [No.] address or password	- Backup	(1) Enable / Disable daily backup
	(3) Enable / Disable IP dongle group [No.] command password		(2) Change backup path
	(4) Change IP dongle group [No.] command password	- SNMP	(1) Enable / Disable SNMP
- Alarm	(1) Enable or Disable alarm		(2) Change SNMP server setting
	(2) Change alarm email server setting		
	(3) Add / Delete alarm mail recipient		

< **Past sys log** > provides a search function in a certain period to find event occurrences in < User >, < Setup >, < Alarm >, < Scan >, < Refresh >, < Temp. >, < Backup > & < SNMP >.

Past System Log view

Logtype: System log

(YYYY / MM / DD)

From: 2012 / 02 / 01

To: 2012 / 02 / 23

(Max. period up to 31 days)

Search

First / Previous 1 2 3 4 5 6 7 8 9 10 Next / Last			
Date (YYYY / MM / DD)	Time	Event	Description
2012 / 02 / 14	16 : 10 : 25	Setup	[admin] : Change IP dongle 01 address or password
2012 / 02 / 14	16 : 09 : 25	Setup	[admin] : Deactivate IP dongle group 02
2012 / 02 / 14	16 : 08 : 25	Setup	[admin] : Deactivate IP dongle group 03
2012 / 02 / 14	16 : 07 : 25	Setup	[admin] : Deactivate IP dongle group 04



Step 3. Usage & operation

< **Status** > provides the users a scan function to monitor the PDUs of each IP dongle group one by one & set the alarm amp for the PDU.

IP dongle groups: 01 02 03 04 05 06 07 08 09 10 11 12 13 14 15
Scan
Stop

IP dongle name:
 IP address:

Level	Name	Location	Circuit A			Circuit B			Total Amp	TH		
			Amp			Amp				Load	°C	%
			Max.	Load	Alarm	Max.	Load	Alarm			-	-
01	Switched_20	Server_Rack_001	16	0.0	13	16	0.0	13	0.0	-	-	
02	Switched_20	Server_Rack_002	16	0.0	13	16	4.6	4	4.6	-	-	
03	Switched_20	Server_Rack_003	16	0.0	13	16	4.5	13	4.5	-	-	
04	Switched_20	Server_Rack_004	16	4.3	13	16	4.3	4	8.6	-	-	
05	Switched_20	Server_Rack_005	16	4.3	13	16	4.0	13	8.3	-	-	
06	Monitor_16	Server_Rack_006	16	4.5	13	-	-	-	4.5	-	-	
07	Monitor_16	Server_Rack_007	16	4.5	13	-	-	-	4.5	-	-	
08	Monitor_16	Server_Rack_008	16	4.0	4	-	-	-	4.4	-	-	
09	Monitor_16	Server_Rack_009	16	4.5	13	-	-	-	4.5	-	-	
10	Monitor_16	Server_Rack_010	16	4.6	13	-	-	-	4.6	-	-	
11	Monitor_16	Server_Rack_011	16	4.7	13	-	-	-	4.7	-	-	
12	Monitor_16	Server_Rack_012	16	4.5	13	-	-	-	4.5	35.0	-	
13	Monitor_24	Server_Rack_013	16	4.5	13	-	-	-	4.5	24.0	-	
14	Monitor_24	Server_Rack_014	16	4.3	13	-	-	-	4.3	25.3	50	
15	Monitor_24	Server_Rack_015	16	4.0	13	-	-	-	4.0	Disconnected		
16	Disconnected	Server_Rack_016	16	-	-	-	-	-	-	-	-	

Auto data refresh: 0000000000 Unlick during data input * Set Alarm Amp in the box

Apply Save new data
 Cancel Cancel new data input
 Search Search new installed PDUs

Press F11 to enlarge or shrink the screen

UM-IPM-01-Q213V2

P.18

www.austin-hughes.com

Step 3. Usage & operation

< **Details** > provides a detailed status about a certain PDU. The user can not only set the name & location for PDU & each outlet, but also power ON / OFF the outlets one by one for switched PDU.

The screenshot displays a PDU management interface. At the top, there are IP dongle groups (01-15) and a dropdown menu for PDU level (01). The selected PDU is 'Y16C13/4C19-32A-MTS' with Name 'Switched_20' and Location 'Server_Rack_001'. The status is 'Connected'. Below this, two circuit panels are shown: 'Circuit A' and 'Circuit B'. Each circuit panel displays 'Max. Amp: 16', 'Load Amp: -', and 'Alarm Amp: -'. The main area contains two tables of outlets. The left table (Circuit A) has 18 outlets, and the right table (Circuit B) has 12 outlets. Each outlet row includes an outlet number, a name, a status (ON/OFF), and a switch button. At the bottom, there are control buttons: 'Apply' (Save new data), 'Cancel' (Cancel new data input), 'Factory default' (Reset PDU to factory settings), and 'Disable monitoring' (Stop monitoring removed PDU). A note states '* Command password requested if a switch ON / OFF outlets'. A footer instruction says 'Press F11 to enlarge or diminish the screen'.

Outlet	Name	Status	Switch
1	IBM_Server_1	ON	OFF
2	IBM_Server_2	ON	OFF
3	IBM_Server_3	ON	OFF
4	Dell_Server_1	ON	OFF
5	Dell_Server_2	ON	OFF
6	Sun_Server_1	ON	OFF
7	Sun_Server_2	ON	OFF
8	Cisco_Router_1	ON	OFF
17	HP_BladeServer_1	OFF	ON
18	HP_BladeServer_2	OFF	ON

Outlet	Name	Status	Switch
9	IBM_Server_4	ON	OFF
10	IBM_Server_5	ON	OFF
11	IBM_Server_6	ON	OFF
12	Dell_Server_3	ON	OFF
13	Dell_Server_4	ON	OFF
14	Sun_Server_3	ON	OFF
15	Sun_Server_4	ON	OFF
16	Cisco_Router_2	ON	OFF
19	HP_BladeServer_3	OFF	ON
20	HP_BladeServer_4	OFF	ON



Step 3. Usage & operation

< Sensor >

IP dongle groups: 01 02 03 04 05 06 07 08 09 10 11 12 13 14 15

PDU level: 14 V20C13M4C19-32A-MTS/TH
 Status: Connected
 Name: Monitor_24
 Location: Server_Rack_014

TH sensor Activate Deactivate

Temp. (°C): Reading: 25.9
 Humid. (%): 50

- DO NOT activate T or TH sensor if no sensor connection.
- Otherwise, it will cause an alarm of sensor disconnection.

Save new data
 Cancel new data input

< PDU log > provides last 5000 PDU log records about a certain PDU by the user's selection. The software will generate a PDU log record in every one minute.

IP dongle groups: 01 02 03 04 05 06 07 08 09 10 11 12 13 14 15

PDU level: 01 V16C13M4C19-32A-MTS Name: Switched_20
 Current status: Connected Location: Server_Rack_001

Date (YYYY/MM/DD)	Time	Name	Model	Status	Circuit A			Circuit B			Total	TH	
					Amp			Amp			Amp	°C	%
					Max.	Load	Alarm	Max.	Load	Alarm	Load		
2012/02/14	16:10:25	Server_Rack_001	V16C13M4C19-32A-MTS	Connected	16	0.0	13	16	0.0	13	0.0	-	-
2012/02/14	16:09:25	Server_Rack_001	V16C13M4C19-32A-MTS	Connected	16	0.0	13	16	0.0	13	0.0	-	-
2012/02/14	16:08:25	Server_Rack_001	V16C13M4C19-32A-MTS	Connected	16	0.0	13	16	0.0	13	0.0	-	-
2012/02/14	16:07:25	Server_Rack_001	V16C13M4C19-32A-MTS	Connected	16	0.0	13	16	0.0	13	0.0	-	-

Press F11 to enlarge or diminish the screen

First / Previous 1 2 3 4 5 6 7 8 9 10 Next / Last

Last 5000 log records.



Step 3. Usage & operation

< **Event** > provides last 5000 events about PDU's configuration & connection and sensor's configuration & connection in a certain IP dongle group.

IP dongle groups: 01 02 03 04 05 06 07 08 09 10 11 12 13 14 15

First / Previous 1 2 3 4 5 6 7 8 9 10 Next / Last Last 5000 log records.

Date <small>(YYYY / MM / DD)</small>	Time	Event	Description
2012 / 02 / 14	15 : 26 : 26	PDU configuration	[admin] : Change outlet name - PDU Level 01 - Outlet 04
2012 / 02 / 14	15 : 26 : 54	PDU configuration	[admin] : Change outlet name - PDU Level 01 - Outlet 03
2012 / 02 / 14	15 : 02 : 22	PDU configuration	[admin] : Change outlet name - PDU Level 01 - Outlet 02
2012 / 02 / 14	15 : 01 : 06	PDU configuration	[admin] : Change outlet name - PDU Level 01 - Outlet 01
2012 / 02 / 14	14 : 58 : 34	PDU configuration	[admin] : Switch outlet on - PDU Level 01 - Outlet 04
2012 / 02 / 13	14 : 50 : 39	PDU configuration	[admin] : Switch outlet on - PDU Level 01 - Outlet 03
2012 / 02 / 13	14 : 50 : 16	PDU configuration	[admin] : Switch outlet on - PDU Level 01 - Outlet 02
2012 / 02 / 13	14 : 48 : 53	PDU configuration	[admin] : Switch outlet on - PDU Level 01 - Outlet 01
2012 / 02 / 13	14 : 48 : 47	PDU configuration	[admin] : Change alarm amp. - PDU Level 01 - Circuit B
2012 / 02 / 13	14 : 48 : 41	PDU configuration	[admin] : Change alarm amp. - PDU Level 01 - Circuit A
2012 / 02 / 13	14 : 48 : 32	PDU configuration	[admin] : Change PDU name - PDU Level 01

The types of event :

<ul style="list-style-type: none"> - PDU connection <ul style="list-style-type: none"> + Disconnection / Reconnection - IP dongle connection <ul style="list-style-type: none"> + Disconnection / Reconnection - Sensor connection <ul style="list-style-type: none"> + Disconnection / Reconnection 	<ul style="list-style-type: none"> - PDU configuration <ul style="list-style-type: none"> (1) Change alarm amp. (Circuit A / Circuit B) (2) Change PDU name (3) Change PDU location (4) Switch outlet on / off (5) Change outlet name (6) Amp. alarm 	<ul style="list-style-type: none"> - Sensor configuration <ul style="list-style-type: none"> (1) Activate / Deactivate TH sensor (2) Change temp. alarm (3) Change humid. alarm (4) Temp. alarm (5) Humid. alarm
---	--	---



Step 3. Usage & operation

< Past log > provides a search function in a certain period to find the log records about a certain PDU or the event occurrences about a certain IP dongle group.

IP dongle groups: 01 02 03 04 05 06 07 08 09 10 11 12 13 14 15

Past Log view (YYYY / MM / DD) (Max. period up to 31 days)

Log type: PDU log Event Level 01

From: 2012 / 02 / 01 To: 2012 / 02 / 23

Search Export (PDU Log only, in CSV format)

First / Previous 1 2 3 4 5 6 7 8 9 10 Next / Last

Date (YYYY/MM/DD)	Time	Name	Model	Status	Circuit A			Circuit B			Total	TH	
					Max.	Load	Alarm	Max.	Load	Alarm	Amp	°C	%
2012/02/14	16:10:25	PDU_name	H4C13-32A-MTS	Connected	16	0.0	5	16	0.0	13	0.0	-	-
2012/02/14	15:09:25	PDU_name	H4C13-32A-MTS	Connected	16	0.0	5	16	0.0	13	0.0	-	-
2012/02/14	15:08:25	PDU_name	H4C13-32A-MTS	Connected	16	0.0	5	16	0.0	13	0.0	-	-
2012/02/14	15:07:25	PDU_name	H4C13-32A-MTS	Connected	16	0.0	5	16	0.0	13	0.0	-	-
2012/02/14	15:06:25	PDU_name	H4C13-32A-MTS	Connected	16	0.0	5	16	0.0	13	0.0	-	-
2012/02/14	15:05:25	PDU_name	H4C13-32A-MTS	Connected	16	0.0	5	16	0.0	13	0.0	-	-
2012/02/14	15:04:25	PDU_name	H4C13-32A-MTS	Connected	16	0.0	5	16	0.0	13	0.0	-	-
2012/02/14	15:03:25	PDU_name	H4C13-32A-MTS	Connected	16	0.0	5	16	0.0	13	0.0	-	-
2012/02/14	15:02:25	PDU_name	H4C13-32A-MTS	Connected	16	0.0	5	16	0.0	13	0.0	-	-
2012/02/14	15:01:25	PDU_name	H4C13-32A-MTS	Connected	16	0.0	5	16	0.0	13	0.0	-	-
2012/02/14	15:00:25	PDU_name	H4C13-32A-MTS	Connected	16	0.0	5	16	0.0	13	0.0	-	-
2012/02/14	15:59:25	PDU_name	H4C13-32A-MTS	Connected	16	0.0	5	16	0.0	13	0.0	-	-
2012/02/14	15:58:24	PDU_name	H4C13-32A-MTS	Connected	16	0.0	5	16	0.0	13	0.0	-	-
2012/02/14	15:57:24	PDU_name	H4C13-32A-MTS	Connected	16	0.0	5	16	0.0	13	0.0	-	-
2012/02/14	15:55:53	PDU_name	H4C13-32A-MTS	Connected	16	0.0	5	16	0.0	13	0.0	-	-
2012/02/14	15:54:53	PDU_name	H4C13-32A-MTS	Connected	16	0.0	5	16	0.0	13	0.0	-	-
2012/02/14	15:53:53	PDU_name	H4C13-32A-MTS	Connected	16	0.0	5	16	0.0	13	0.0	-	-
2012/02/14	15:52:53	PDU_name	H4C13-32A-MTS	Connected	16	0.0	5	16	0.0	13	0.0	-	-
2012/02/14	15:51:53	PDU_name	H4C13-32A-MTS	Connected	16	0.0	5	16	0.0	13	0.0	-	-
2012/02/14	15:50:53	PDU_name	H4C13-32A-MTS	Connected	16	0.0	5	16	0.0	13	0.0	-	-
2012/02/14	15:49:53	PDU_name	H4C13-32A-MTS	Connected	16	0.0	5	16	0.0	13	0.0	-	-
2012/02/14	15:48:53	PDU_name	H4C13-32A-MTS	Connected	16	0.0	5	16	0.0	13	0.0	-	-
2012/02/14	15:47:53	PDU_name	H4C13-32A-MTS	Connected	16	0.0	5	16	0.0	13	0.0	-	-
2012/02/14	15:46:53	PDU_name	H4C13-32A-MTS	Connected	16	0.0	5	16	0.0	13	0.0	-	-
2012/02/14	15:45:53	PDU_name	H4C13-32A-MTS	Connected	16	0.0	5	16	0.0	13	0.0	-	-

Completed

Part III. Data Export

- 1) Select IP Dongle group.
- 2) Tick the box of PDU log & ignore the PDU level selection.
- 3) Enter the period of PDU log to export. (min. 1 day, max. 31 days)
- 4) Click **Export** and a **Message from webpage** dialog box pops up.
- 5) Click **OK** to confirm the export process. It may take several minutes to complete.

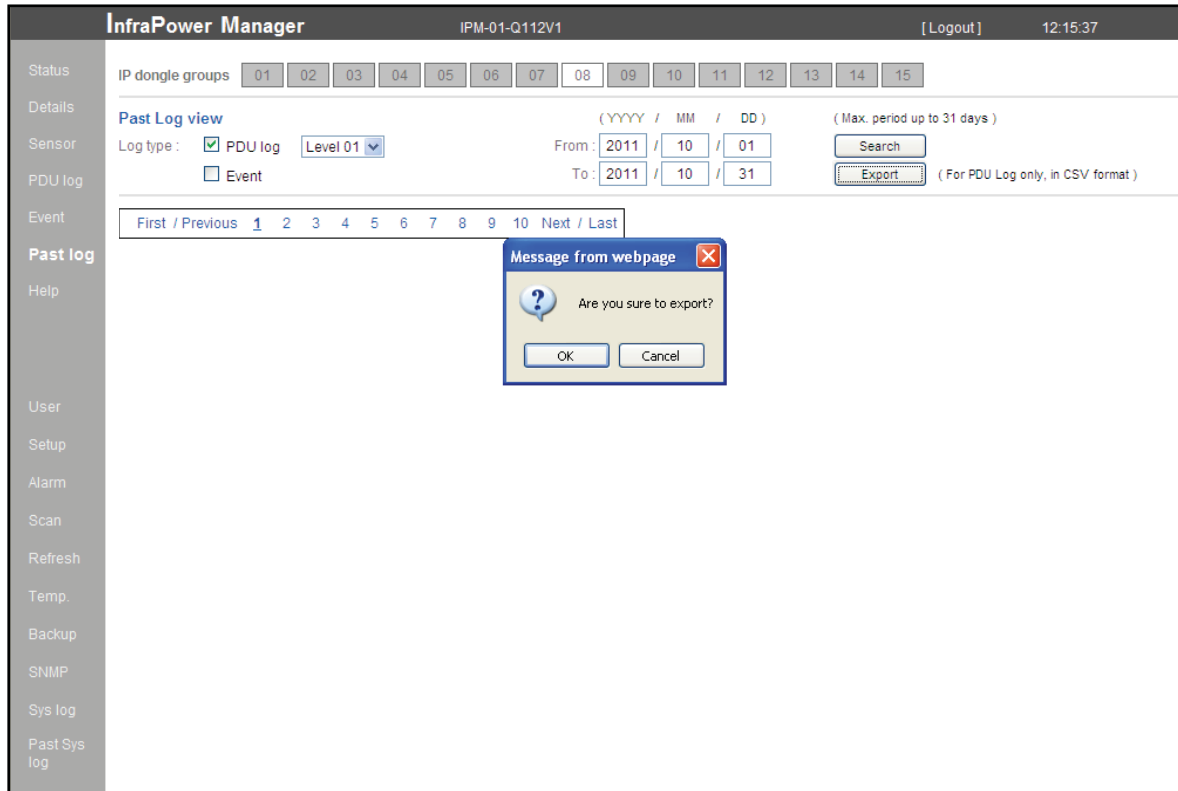

The screenshot shows the 'InfraPower Manager' interface for device IPM-01-Q112V1. The 'Past Log view' section is active, showing 'Log type' with 'PDU log' selected and 'Level 01' chosen. The date range is set from '2011 / 10 / 01' to '2011 / 10 / 31'. An 'Export' button is visible. A modal dialog box titled 'Message from webpage' is overlaid on the screen, containing a question mark icon and the text 'Are you sure to export?' with 'OK' and 'Cancel' buttons.



Processing.....

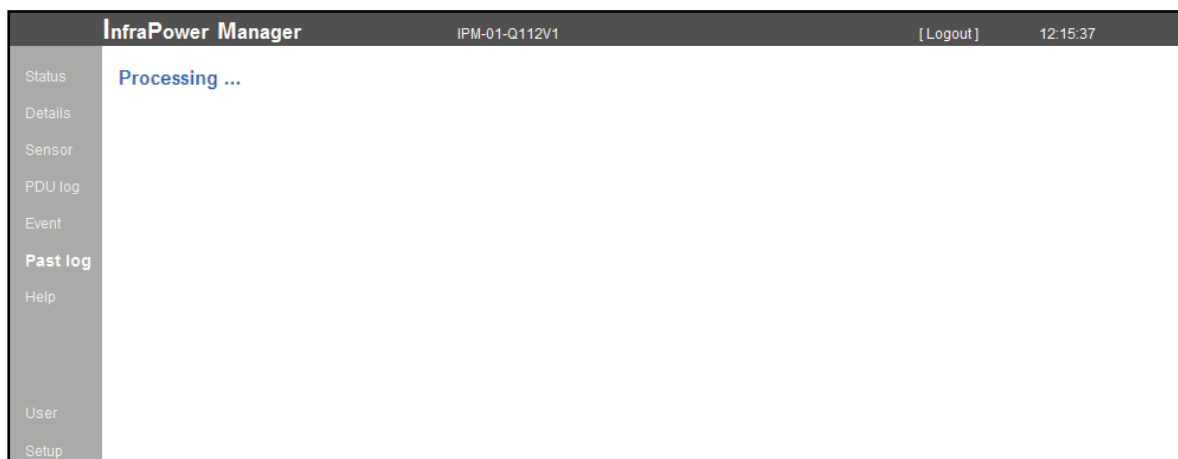

The screenshot shows the 'InfraPower Manager' interface for device IPM-01-Q112V1. The 'Status' section now displays 'Processing ...' in blue text. The rest of the interface remains the same as in the previous screenshot.



- 6) Right click the PDU level below.
- 7) Select **Save Target As** to download the PDU log file.

InfraPower Manager IPM-01-Q112V1 [Logout] 12:15:37

Status: IP dongle groups 01 02 03 04 05 06 07 08 09 10 11 12 13 14 15

Details: **Past Log view** (YYYY / MM / DD) (Max. period up to 31 days)

Sensor: Log type: PDU log **Level 01** From: 2011 / 10 / 01 Search

PDU log: Event To: 2011 / 10 / 31 Export (PDU Log only, in CSV format)

Event: First / Previous 1 2 3 4 5 6 7 8 9 10 Next / Last

Past log

Help: **To download the PDU log file, please:**
 (1) Right click the PDU level below
 (2) Select **Save target as** to download the PDU log file
 Please take the step (1) & (2) for the other PDU levels one by one

User: - PDU Level 01
 Setup: - PDU Level 02
 Alarm: - PDU Level 03
 Scan: - PDU Level 04
 Refresh: - PDU Level 05
 Temp.: - PDU Level 06
 Backup: - PDU Level 07
 SNMP: - PDU Level 08
 Sys log: - PDU Level 09
 Past Sys log: - PDU Level 10
 - PDU Level 11
 - PDU Level 12
 - PDU Level 13
 - PDU Level 14
 - PDU Level 15
 - PDU Level 16

Context menu for PDU Level 01:
 Open
 Open in New Tab
 Open in New Window
Save Target As...
 Print Target

 Cut
 Copy
 Copy Shortcut
 Paste

 Blog with Windows Live
 E-mail with Windows Live
 Translate with Live Search
 All Accelerators

 Add to Favorites...

 Properties



- 8) Select the path & click **Save** to complete the download process.
Please take Step 6, 7 & 8 for the other PDU levels one by one.

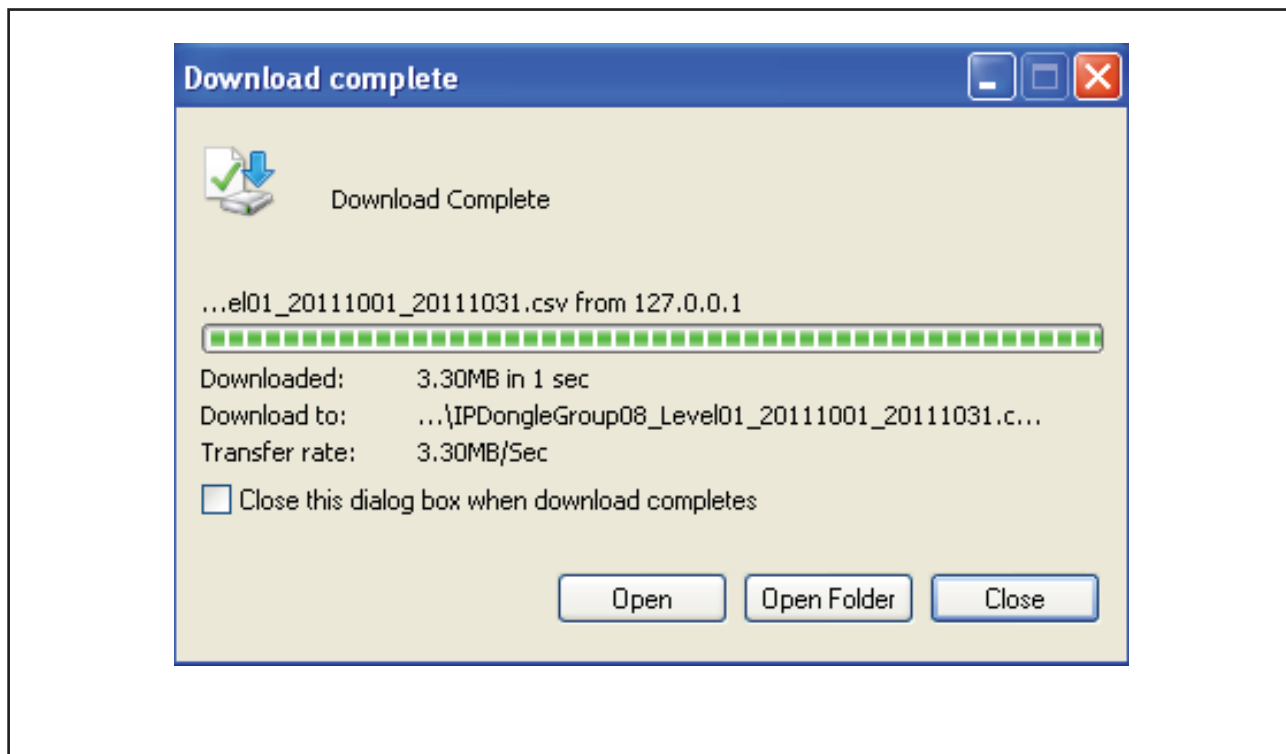
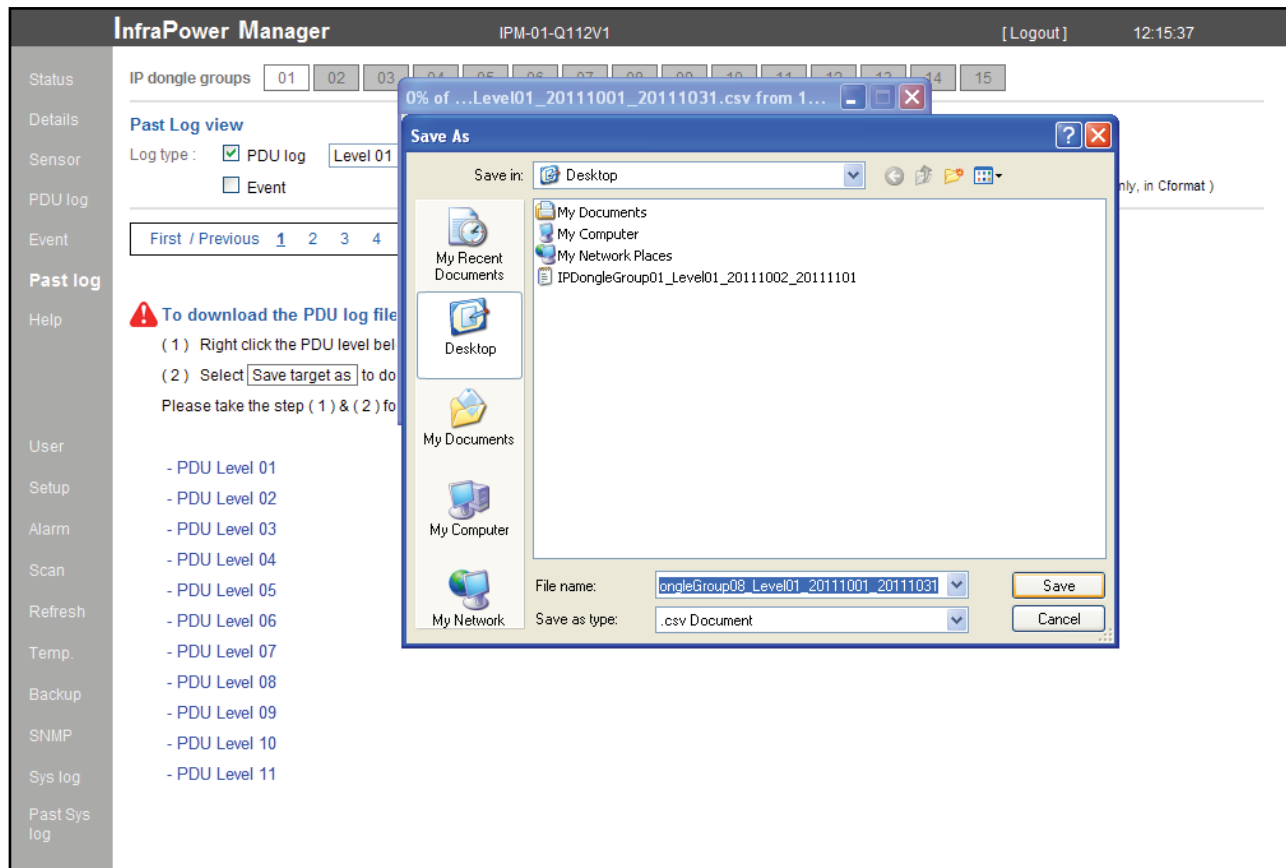

- Below is the sample of a PDU log file in MS Excel, CSV format.
- User can use the data for analysis purpose.

	A	B	C	D	E	F	G	H	I	J	K	L
1	Date	Time	Model	Name	Status	Circuit A max. amp.	Circuit A load amp.	Circuit A alarm amp.	Circuit B max. amp.	Circuit B load amp.	Circuit B alarm amp.	Total load amp.
2	2011/10/01	23:59:14	V16C13/4C19-32A-MTS	Switched_20	Connected	16	0	13	16	0	13	0
3	2011/10/01	23:58:13	V16C13/4C19-32A-MTS	Switched_20	Connected	16	0	13	16	0	13	0
4	2011/10/01	23:57:12	V16C13/4C19-32A-MTS	Switched_20	Connected	16	0	13	16	0	13	0
5	2011/10/01	23:56:11	V16C13/4C19-32A-MTS	Switched_20	Connected	16	0	13	16	0	13	0
6	2011/10/01	23:55:10	V16C13/4C19-32A-MTS	Switched_20	Connected	16	0	13	16	0	13	0
7	2011/10/01	23:54:10	V16C13/4C19-32A-MTS	Switched_20	Connected	16	0	13	16	0	13	0
8	2011/10/01	23:53:09	V16C13/4C19-32A-MTS	Switched_20	Connected	16	0	13	16	0	13	0
9	2011/10/01	23:52:08	V16C13/4C19-32A-MTS	Switched_20	Connected	16	0	13	16	0	13	0
10	2011/10/01	23:51:07	V16C13/4C19-32A-MTS	Switched_20	Connected	16	0	13	16	0	13	0
11	2011/10/01	23:50:06	V16C13/4C19-32A-MTS	Switched_20	Connected	16	0	13	16	0	13	0
12	2011/10/01	23:49:05	V16C13/4C19-32A-MTS	Switched_20	Connected	16	0	13	16	0	13	0
13	2011/10/01	23:48:04	V16C13/4C19-32A-MTS	Switched_20	Connected	16	0	13	16	0	13	0
14	2011/10/01	23:47:03	V16C13/4C19-32A-MTS	Switched_20	Connected	16	0	13	16	0	13	0
15	2011/10/01	23:46:02	V16C13/4C19-32A-MTS	Switched_20	Connected	16	0	13	16	0	13	0
16	2011/10/01	23:45:01	V16C13/4C19-32A-MTS	Switched_20	Connected	16	0	13	16	0	13	0
17	2011/10/01	23:44:00	V16C13/4C19-32A-MTS	Switched_20	Connected	16	0	13	16	0	13	0
18	2011/10/01	23:42:59	V16C13/4C19-32A-MTS	Switched_20	Connected	16	0	13	16	0	13	0
19	2011/10/01	23:41:58	V16C13/4C19-32A-MTS	Switched_20	Connected	16	0	13	16	0	13	0
20	2011/10/01	23:40:57	V16C13/4C19-32A-MTS	Switched_20	Connected	16	0	13	16	0	13	0
21	2011/10/01	23:39:56	V16C13/4C19-32A-MTS	Switched_20	Connected	16	0	13	16	0	13	0
22	2011/10/01	23:38:55	V16C13/4C19-32A-MTS	Switched_20	Connected	16	0	13	16	0	13	0
23	2011/10/01	23:37:54	V16C13/4C19-32A-MTS	Switched_20	Connected	16	0	13	16	0	13	0
24	2011/10/01	23:36:53	V16C13/4C19-32A-MTS	Switched_20	Connected	16	0	13	16	0	13	0
25	2011/10/01	23:35:52	V16C13/4C19-32A-MTS	Switched_20	Connected	16	0	13	16	0	13	0
26	2011/10/01	23:34:51	V16C13/4C19-32A-MTS	Switched_20	Connected	16	0	13	16	0	13	0
27	2011/10/01	23:33:50	V16C13/4C19-32A-MTS	Switched_20	Connected	16	0	13	16	0	13	0
28	2011/10/01	23:32:49	V16C13/4C19-32A-MTS	Switched_20	Connected	16	0	13	16	0	13	0
29	2011/10/01	23:31:48	V16C13/4C19-32A-MTS	Switched_20	Connected	16	0	13	16	0	13	0
30	2011/10/01	23:30:47	V16C13/4C19-32A-MTS	Switched_20	Connected	16	0	13	16	0	13	0
31	2011/10/01	23:29:46	V16C13/4C19-32A-MTS	Switched_20	Connected	16	0	13	16	0	13	0
32	2011/10/01	23:28:45	V16C13/4C19-32A-MTS	Switched_20	Connected	16	0	13	16	0	13	0
33	2011/10/01	23:27:44	V16C13/4C19-32A-MTS	Switched_20	Connected	16	0	13	16	0	13	0
34	2011/10/01	23:26:44	V16C13/4C19-32A-MTS	Switched_20	Connected	16	0	13	16	0	13	0
35	2011/10/01	23:25:43	V16C13/4C19-32A-MTS	Switched_20	Connected	16	0	13	16	0	13	0
36	2011/10/01	23:24:42	V16C13/4C19-32A-MTS	Switched_20	Connected	16	0	13	16	0	13	0
37	2011/10/01	23:23:41	V16C13/4C19-32A-MTS	Switched_20	Connected	16	0	13	16	0	13	0
38	2011/10/01	23:22:40	V16C13/4C19-32A-MTS	Switched_20	Connected	16	0	13	16	0	13	0
39	2011/10/01	23:21:39	V16C13/4C19-32A-MTS	Switched_20	Connected	16	0	13	16	0	13	0
40	2011/10/01	23:20:38	V16C13/4C19-32A-MTS	Switched_20	Connected	16	0	13	16	0	13	0
41	2011/10/01	23:19:37	V16C13/4C19-32A-MTS	Switched_20	Connected	16	0	13	16	0	13	0
42	2011/10/01	23:18:36	V16C13/4C19-32A-MTS	Switched_20	Connected	16	0	13	16	0	13	0
43	2011/10/01	23:17:35	V16C13/4C19-32A-MTS	Switched_20	Connected	16	0	13	16	0	13	0
44	2011/10/01	23:16:34	V16C13/4C19-32A-MTS	Switched_20	Connected	16	0	13	16	0	13	0
45	2011/10/01	23:15:33	V16C13/4C19-32A-MTS	Switched_20	Connected	16	0	13	16	0	13	0
46	2011/10/01	23:14:32	V16C13/4C19-32A-MTS	Switched_20	Connected	16	0	13	16	0	13	0
47	2011/10/01	23:13:31	V16C13/4C19-32A-MTS	Switched_20	Connected	16	0	13	16	0	13	0

Completed

Part IV. FAQ

< 4.1 > InfraPower Manager - IPM-01

1. What is InfraPower Manager?

The InfraPower Manager IPM-01 is a Windows based system to consolidate management of max. 240 PDUs via 15 IP dongles, using a simple web interface which monitors and controls the MTS / MT PDUs in the data center. Authorized users have a secure control over outlets to power ON / OFF at the managed device level. It also provides the detailed PDU and event logged records, and sends alarm email once ampere overloading.

Please find the link below:

<http://www.austin-hughes.com/support/software/infrapower/IPM-01.msi>

2. Which OS platform does IPM-01 support?

- MS Windows XP Professional with SP3 (32bit only)
- MS Windows 7 Professional with SP1
- MS Windows 7 Ultimate with SP1
- MS Windows Server 2003 R2 Standard Edition with SP2
- MS Windows Server 2008 Standard Edition SP2
- MS Windows Server 2008 R2 Standard Edition SP1

 **Ensure the user logins in the management PC as a member of “Administrators” Group before IPM-01 Installation and execution.**

3. Which database does the IPM-01 support?

PostgreSQL

4. What is the PostgreSQL default password for IPM-01?

1qaz2WSX

5. How can I receive alarm email and get full log report?

Ensure that IPM-01 is executed and the alarm server is configured properly and being enabled.

6. What is the default login name & password of IPM-01?

Default login name “admin” & password “00000000”

7. What is the command password of IPM-01?

Each IP dongle group has its command password. It will be requested for any PDU configuration and control. The administrator can set different command password for different IP dongle group or all IP dongle groups use the same password.

8. The MTS / MT PDUs can't be found by IPM-01?

Please double check the cable connection and the level setting of each PDU. If a cascade chain has duplicate the level PDUs, it will cause this problem.

9. Is it possible to manage the MTS / MT PDUs from different workstations?

Yes, the InfraPower manager supports 5 concurrent login users from different workstations.

10. Can the MTS / MT PDUs connect the KVM switch?

Yes, only CyberView IP KVM switch. In this connection, IP dongle will not be needed.

For the details, please find the link below:

<http://www.austin-hughes.com/support/usermanual/infrapower/UM-IPS-01.pdf>

11. Does the IP dongle support web browser access?

Yes, the IP dongle features a browser-based built-in graphical user interface (GUI) that can configure, monitor and power control to individual outlets.

For the details, please find the link below:

<http://www.austin-hughes.com/support/usermanual/infrapower/UM-PPS-01.pdf>

< 4.2 > IP dongle

1. What is the IP dongle?

The IP dongle provides a simple and economical way to consolidate management of max. 16 pcs MTS / MT PDUs, by a single IP connection to the network.

2. What is the IP setup utilities?

This is a windows application used to assign the IP address of IP dongle. You can download the IP setup utilities from the link below:

<http://www.austin-hughes.com/support/utilities/infrapower/IPdongleSetup.msi>

3. Does the IP dongle support DHCP (Dynamic Host Configuration Protocol)?

No, the IP dongle only works with static IP-address.

4. How can I reset the IP dongle password to the factory default value?

Press the reset button of IP dongle for at least 8 seconds to reset the IP dongle to the factory default value as below:

IP address: 192.168.0.1

Password: 00000000

5. Will the reset of IP dongle affect the power to the outlets?

No, the IP dongle operates on a separate circuit, so the power to the outlets will remain unchanged.

6. How can I replace a failed IP dongle?

As the IP dongle is hot swappable, without power disconnection, you can unplug the RJ45 connector and slide out the failed IP dongle from the MTS / MT PDU. Then replace a new one for the PDU and re-configure the IP address to fit your network setting. (Please refer to the user manual P. 5)

< 4.3 > Meter for MTS & MT PDU

1. What is feature of the MT PDU?

The MT PDU offers simple & highly reliable power distribution to multiple equipments, and built-in a digital ampere meter indicates the total power consumption of equipment connected to the PDU. The digital ampere meter has an interface which can connect to an IP dongle to the ethernet network, which allows managers to real-time remote monitor the PDU load thru the InfraPower manager (IPM-01).

2. What is feature of the MTS PDU?

The MTS PDUs offers the same features as MT PDUs, with an addition remote control power capability to individual PDU outlets. The remote outlet power control allows power on/off functionality for power recycling to reboot locked-up equipment and to avoid unauthorized use of individual outlets.

3. Which types of outlet can MTS PDU support?

The MTS PDU supports IEC 60320/C13, IEC 60320/C19, NEMA 5-15/20R & BS1363 outlet type.

4. Can the MTS and MT PDUs cascade together?

Yes, the MTS & MT model PDUs can connect together as a cascade chain.

5. If one of the cascaded MTS / MT PDU loses power, will it affect other PDUs in the same chain?

No, the other cascaded MTS / MT PDUs in upper & lower level will not be affected.

6. What is the maximum cabling distance between two cascaded PDUs?

Up to 20 meter (66 feet) of CAT. 5 / 6 cable.

7. What is the maximum cascade level of the MTS / MT PDU in a chain?

16 levels

< 4.4 > Others

1. Does the InfraPower PDU has the overpower protection?

Yes, the PDU provides the resettable fuse or optional circuit breaker for the overpower protection.

2. What is the standard inlet cable length of InfraPower?

3 meter (9.9 feet).

3. Where can I find the Catalogue / User manual /Model list / Wire diagram of InfraPower PDUs?

Please visit the www.austin-hughes.com

4. How can we get a further support?

Please send the email to support@infra-power.com or sales@infra-power.com

Part V. Troubleshooting

< 5.1 > PDU disconnection

1. GUI shows **a certain level PDU** disconnected

Step 1. PDU power off ?

Check the PDU is power ON or not.

Step 2. PDU level setting duplicated in the same PDU group ?

Check and make sure PDU level is unique and not duplicated in the same PDU group.
(Please refer to P.1 for the PDU level setting)

2. GUI shows **from a certain level PDU to the last one** disconnected

Step 1. Cable disconnected, loose or defective ?

Check the Cat. 5/6 cable connection to PDUs and network devices. Make sure the connectors are firmly attached. And check if any defects on your cable or not. If yes, replace a new one.

Step 2. The first disconnected PDU failed ?

Unplug the Cat. 5/6 cable on the first disconnected PDU, then plug it to the second disconnected PDU to check if the problem caused by the first disconnected PDU.

3. GUI shows **the whole group of PDU(s)** disconnected

Step 1. Cable disconnected, loose or defective ?

Check the Cat. 5/6 cable connection to PDUs and network devices. Make sure the connectors are firmly attached. And check if any defects on your cable or not. If yes, replace a new one.

Step 2. IP dongle failed ?

- i. Check if the network setting of the IP dongle is correct or not. If duplicated IP address is in a network, it may cause such problem.
- ii. Disconnect the IP dongle from the network and try to direct connect the Cat. 5/6 cable from IP dongle < LAN > port to a computer network port and use IP Setup utilities to check if the IP dongle can be found or not. If it cannot be found, the IP dongle may be failed.

Step 3. 1st level PDU failed ?

Move the IP dongle from 1st level PDU to 2nd level PDU to check if the problem caused by 1st level PDU's failure or not. If yes, replace 1st level PDU.

< 5.2 > Replacement, Removal or addition for PDU & IP dongle

1. How to replace the **failed IP dongle** ?

- Step 1. Prepare a new IP dongle.
- Step 2. Disable alarm email in **<Alarm>** page.
- Step 3. Replace the failed IP dongle with the new one on 1st level PDU.
- Step 4. Configure the setting of the new IP dongle same as the old one.
(Please refer to P.5 for IP dongle configuration)
- Step 5. Click **Start Connection** in **<Status>** page for the relevant IP dongle.
- Step 6. Enable alarm email in **<Alarm>** page again.

2. How to replace the **failed 1st level PDU** with a new one ?

- Step 1. Prepare a new PDU and set the PDU to 1st level.
(Please refer to P.1 for the PDU level setting)
- Step 2. Disable alarm email in **<Alarm>** page.
- Step 3. Power off & unplug the device(s) which connected to the PDU.
- Step 4. Power off & remove the failed 1st level PDU from connection.
- Step 5. Install the IP dongle on the new 1st level PDU.
- Step 6. Install and connect the new PDU.
- Step 7. Power on the new PDU and connect to the device(s).
- Step 8. Click Start Connection in **<Status>** page for the relevant IP dongle.
- Step 9. Configure the new PDU in **<Status>** and **<Details>** page such as
Alarm Amp , Name, Location...
- Step 10. Enable alarm email in **<Alarm>** page.

3. How to replace a **failed certain level PDU** with a new one ?

- Step 1. Prepare a new PDU and set the PDU level accordingly.
(Please refer to P.1 for the PDU level setting)
- Step 2. Prepare an appropriate length Cat. 5/6 cable.
- Step 3. Disable alarm email in **<Alarm>** page.
- Step 4. Use the Cat. 5/6 cable to bridge over the failed PDU which will be replaced to minimize log/data loss.
- Step 5. Power off & unplug the device(s) which connected to the failed PDU.
- Step 6. Power off & remove the failed PDU from connection.
- Step 7. Install the new PDU, cancel the cable-bridging and reconnect the PDU to the last and next one.
- Step 8. Power on the new PDU and connect to the device(s).
- Step 9. Configure the new PDU in **<Status>** and **<Details>** page such as
Alarm Amp, Name, Location...
- Step 10. Enable alarm email in **<Alarm>**.





Ignore step 2 & 4 if the failed PDU is in the last level.

< 5.2 > Replacement, Removal or addition for PDU & IP dongle

4. How to move out a PDU (without a replacement) ?

- Step 1. Prepare an appropriate length Cat. 5/6 cable.
- Step 2. Disable alarm email in <Alarm> page.
- Step 3. Use the Cat. 5/6 cable to bridge over the removed PDU to minimize log/data loss.
- Step 4. Power off & unplug the device(s) which connected to the PDU.
- Step 5. Power off & remove the PDU from connection.
- Step 6. Click **Disable Monitoring** in <Details> page to stop monitoring the removed PDU.
- Step 7. Enable alarm email in <Alarm> page.

 If the removed PDU **NOT** in the last level, you **MUST** reconfigure and reset the level for the affected PDU(s) which next to the removed PDU.

 Ignore step 1 & 3 if the removed PDU is in the last level.

5. How to add an extra PDU to an existing PDU group ?

- Step 1. Prepare a PDU and set the PDU level accordingly.
(Please refer to P.1 for the PDU level setting)
- Step 2. Prepare an appropriate length Cat. 5/6 cable.
- Step 3. Disable alarm email in <Alarm> page.
- Step 4. Install and connect the new PDU.
- Step 5. Power on the new PDU.
- Step 6. Click **Search** in <Status> page to search the new installed PDU.
- Step 7. Configure the new PDU in <Status> and <Details> page such as **Alarm Amp , Name, Location...**
- Step 8. Enable alarm email in <Alarm> page.

 If the added PDU **NOT** in the last level, you **MUST** reconfigure and reset the level for the affected PDU(s) which next to the added PDU.

The company reserves the right to modify product specifications without prior notice and assumes no responsibility for any error which may appear in this publication.

All brand names, logo and registered trademarks are properties of their respective owners.

Copyright 2013 Austin Hughes Electronics Ltd. All rights reserved.