

SRS10 (SRS11 / SRS13 / SRS14) Series

Digital Controller

Instruction Manual

Thank you for purchasing a Shimaden Digital Controller. After making sure the product fits the desired description, you should carefully read the instructions and get a good understanding of the contents before attempting to operate the equipment.

Request

The instruction manual should be kept in a handy place where the end user can refer to it when necessary.

Preface

The instruction manual was written for those who perform wiring, installation and routine maintenance for the SRS10 (SRS11/SRS13/SRS14) Series. The instruction manual contains a description of the operating method, functions, wiring, mounting method and precautions when handling the SRS10 (SRS11/SRS13/SRS14) Series (hereinafter referred to as the SRS10 Series unless a separate description is required). You should therefore keep it in a handy place to refer to when operating and handling the equipment. Be sure to observe all precautions and adhere to the procedures provided in the manual. The instruction manual assumes that fixed value control is applied. For information on programming function and communication (optional items), see the instruction manual for the individual function.

SHIMADEN CO., LTD.

Contents

| | | | |
|---|----------|--|-----------|
| Request | 1 | 6. Screen explanation and setting items | 16 |
| Preface | 1 | 7. Measuring range codes | 23 |
| 1. Safety rules | 3 | 8. Explanation of functions | 24 |
| 2. Introduction | 3 | 8-1. Events | 24 |
| 2-1. Preliminary check..... | 3 | (1) Alarm action | 24 |
| (1) Model code check..... | 4 | (2) Event standby action selection..... | 24 |
| (2) Accessories check..... | 4 | (3) Event selection alarm action diagrams | 24 |
| 2-2. Notes on use | 4 | (4) Event status output action..... | 24 |
| 3. Installation and wiring | 4 | 8-2. P.I.D. | 25 |
| 3-1. Installation site (environmental conditions) | 4 | (1) P (Proportional action)..... | 25 |
| 3-2. Mounting | 5 | (2) I (Integral time) | 25 |
| 3-3. External dimensions and panel cutout | 5 | (3) D (Derivative time)..... | 25 |
| 3-4. Wiring | 6 | (4) MR (Manual reset) | 25 |
| 3-5. Terminal layout | 6 | 8-3. Control output | 25 |
| 3-6. Terminal arrangement table..... | 7 | (1) Lower limit and higher limit setting limiter..... | 25 |
| 3-7. Operation preparations | 7 | (2) Proportional cycling time | 26 |
| 4. Names and functions of parts on front panel | 8 | (3) Control output characteristics | 26 |
| 5. Parameter diagram and setting | 9 | 8-4. External control input (DI) | 26 |
| 5-1. Parameter diagram..... | 9 | (1) Controller action execution EXE1 (RUN1)..... | 26 |
| 5-2. Display when power is applied | 11 | (2) Controller action execution EXE2 (RUN2)..... | 26 |
| 5-3. Switching screens | 11 | (3) Manual output (MAN)..... | 26 |
| (1) Switching screens within screen group 0 | 11 | (4) Auto tuning execution (AT) | 26 |
| (2) Switching between screen group 0 and screen group 1 | 11 | (5) SV external selection (ESV2)..... | 27 |
| (3) Switching screens within screen group 1 | 11 | (6) Program (PROG)..... | 27 |
| (4) Switching to screen group 2 | 12 | (7) Hold signal (HLD)..... | 27 |
| (5) Switching screens within screen group 2..... | 12 | (8) Advance (ADV)..... | 27 |
| (6) Switching to screen group 3 | 12 | (9) Start pattern external selection 2 bits (PTN2)..... | 27 |
| (7) Switching to screen group 4 | 12 | (10) Start pattern external selection 3 bits (PTN3)..... | 27 |
| (8) Switching screens within screen group 4..... | 12 | (11) Total unlatching (L_RS) | 27 |
| (9) Set data modification..... | 12 | 8-9. Soft start | 27 |
| 5-4. Auto return function | 13 | (1) Conditions that trigger soft start | 27 |
| 5-5. Screen group 0 setting | 13 | (2) Conditions that cancel soft start..... | 28 |
| (1) Setting target set values (SV) | 13 | 9. Causes and remedy of trouble and errors | 28 |
| (2) Manual setting of control output..... | 13 | 9-1. Causes and remedy of trouble | 28 |
| (3) Auto tuning (AT) | 14 | 9-2. Causes and remedy of errors | 28 |
| (4) Standby (STBY) / execution (EXE) | 15 | (1) Abnormal measured input..... | 28 |
| (5) Event setting..... | 15 | (2) Heater break/loop alarm errors | 28 |
| (6) Multi SV (target set values)..... | 15 | 10. Parameter setting record | 29 |
| | | 11. Specifications | 31 |

1. Safety rules

Safety rules, precautions concerning equipment damage, additional instructions and notes are written based on the following headings.

⚠ WARNING: Matters that could result in injury or death if instructions are not followed.

⚠ CAUTION: Matters that could result in equipment damage if instructions are not followed.

NOTE: Additional instructions or notes.

⚠ WARNING

The SRS10 Series digital controllers are designed to control temperature, humidity and other physical amounts for general industrial equipment.

You should either take appropriate safety measures or avoid using for control that could have a serious effect on human life.

The manufacturer shall not be liable for an accident that results if used without taking appropriate safety measures.

- The digital controller should be used so the terminal elements in the control box, etc., are not touched by humans.
- Do not remove the controller from its case, or insert your fingers or electric conductors inside the case. Doing so could result in electric shock or accident involving death or serious injury.

⚠ CAUTION

If there is danger of damage to any peripheral device or equipment due to failure of the controller, you should take appropriate safety measures such as mounting a fuse or overheating prevention device.

The manufacturer shall not be liable for an accident that results if used without taking appropriate safety measures.

- Controller labels and alert mark ⚠
Alert marks ⚠ are printed on the terminal label of the case.
You could be shocked if you touch charged parts. **The alert marks are provided to call your attention to this.**
- Provide a switch or breaker as a means of cutting off power for external power circuit connected to the power terminal of the controller.
Mount a switch or breaker near the controller where the operator can get to it easily and label it as an electrical breaker for the controller.
Use a switch or breaker that conforms to requirements of IEC60947.
- Fuses
The controller does not have a built-in fuse. Be sure to mount a fuse on the power circuit connected to the power terminal. Provide a fuse between the switch or breaker and the controller. Mount on the L side of the power terminal.
Fuse rating/characteristics: 250V AC, 0.5A/medium time-lagged type or time-lagged type
Use a fuse that conforms to requirements of IEC60127.
- Voltage/current of load connected to the output terminal and EV terminal should be within the rating.
Using voltage/current that exceeds the rating could shorten the life of the controller by raising the temperature, and could result in equipment failure. For rating, see “11. Specifications.”
Connect equipment that conforms to requirements for IEC61010 to the output terminal.
- Do not apply voltage/current other than rated input to the input terminal.
Doing so could shorten product life and lead to equipment failure.
For rating, see “11. Specifications.”
If the input is voltage or current, connect equipment that conforms to IEC61010 to the input terminal.
There are draft holes in the controller for heat to escape from. Do not allow foreign matter such as metal to get into the holes. Doing so could result in equipment failure or fire.
- Do not allow the draft holes to become clogged with dust, etc.
Doing so could shorten the life of the product due to temperature rise or insulation deterioration, and could result in equipment failure or fire.
For space between instruments, see “3-3. External dimensions and panel cutout.”
- Repeating endurance tests such as dielectric strength, noise resistance and surge resistance could negatively affect the controller.
- The user should absolutely not modify or use the controller other than the way it was intended.

2. Introduction

2-1. Preliminary check

The controller has undergone sufficient quality control inspections, but you should check the specification code/appearance and make sure you have all the accessories to make sure nothing is missing or damaged.

Compare the specification code on the case with the following to make sure it is the product you ordered.

The SRS10 Series offers a selection of two codes: SRS11 and SRS13/14.

(1) Model code check

(SRS11 model code)

SRS11-8 Y Y-90-P 1 1 1 0

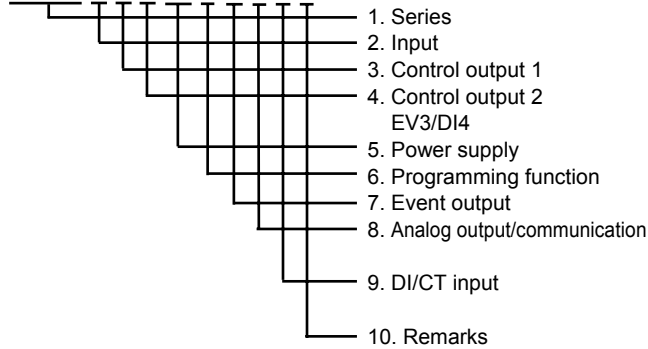

SRS11

8: Multi-input, thermocouple, R.T.D., voltage (mV) 6: Voltage (V)
 Y: Contact I: Current P: SSR drive voltage V: Voltage
 N: None Y: Contact I: Current P: SSR drive voltage V: Voltage
 E: Event output 1 point (EV3) D: External control input 1 point (DI4)
 90: 100-240V AC 08: 24V AC/DC
 N: None P: With (4 patterns, max. 32 steps)
 0: None 1: Event output 2 points (EV1, EV2)
 0: None 3: Voltage (0 ~ 10 mV) 4: Current (4 ~ 20 mA)
 6: Voltage (0 ~ 10 V) 5: communication (RS-485)
 0: None 1: CT 2 points input (Can be selected if control output 1 or 2 is Y, P)
 2: External control input 3 points
 0: None 9: With

(SRS13/SRS14 model code)

SRS13-8 Y Y-90-P 1 4 1 2 5 0

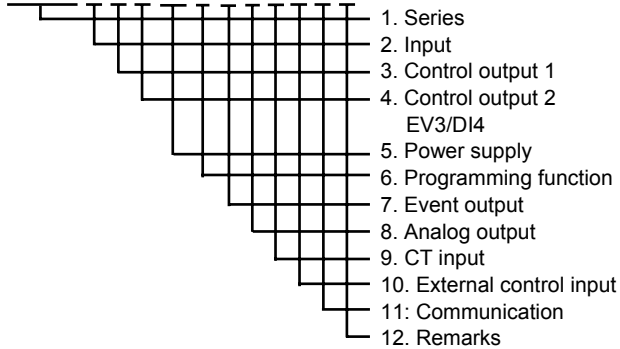

SRS13 or SRS14

8: Multi-input, thermocouple, R.T.D., voltage (mV) 6: Voltage (V)
 Y: Contact I: Current P: SSR drive voltage V: Voltage
 N: None Y: Contact I: Current P: SSR drive voltage V: Voltage
 E: Event output 1 point (EV3) D: External control input 1 point (DI4)
 90: 100-240V AC 08: 24V AC/DC
 N: None P: With (4 patterns, max. 32 steps)
 0: None 1: Event output 2 points (EV1, EV2)
 0: None 3: Voltage (0 ~ 10 mV) 4: Current (4 ~ 20 mA) 6: Voltage (0 ~ 10 V)
 0: None 1: CT input 2 points (Can be selected if control output 1 or 2 is Y, P)
 0: None 2: Control input 3 points (DI1, DI2, DI3)
 0: None 5: RS-485
 0: None 9: With

(2) Accessories check

| | |
|---|---------|
| Instruction manual | 1 copy |
| Communication interface instruction manual (if communication optional item added) | 1 copy |
| Programming function instruction manual (if programming function optional item added) | 1 copy |
| Unit seals | 1 sheet |

Note: Receiving impedance for current input (250Ω, 0.1%), current detector for heater break alarm (CT) and terminal cover are sold separately as optional items and are not included with the controller.

Note: In the event you want to inquire about a product defect, missing accessory or other matter, please contact your nearest Shimaden agent.

2-2. Notes on use

Do not press front panel keys with a hard or pointed object. Press lightly with your fingertips.
 To clean, wipe lightly with a dry cloth. Do not use solvents such as thinner.

3. Installation and wiring

3-1. Installation site (environmental conditions)

Environmental conditions for operations

The controller is designed to be used under the following conditions. Observe the following environmental conditions when using:

- ① Must be used indoors
- ② Max. elevation: 2000m
- ③ Ambient temperature: -10 to 50°C
- ④ Ambient humidity: Max. 90%RH, no condensation
- ⑤ Transient over voltage category: II
- ⑥ Pollution class: 2 (IEC 60664)



CAUTION

Do not use the controller in the following locations. Doing so could lead to equipment failure, damage or fire.

- * Places exposed to flammable or corrosive gases, oil mist, or excessive dust that could cause insulation to deteriorate.
- * Places subject to vibration or impact
- * Places near strong electric circuit or places subject to inductive interference
- * Places exposed to water dripping or direct sunlight
- * Places where the controller is struck directly by air from heater or air conditioner

3-2. Mounting

⚠ CAUTION

In order to maintain safety and function, do not remove the case from the controller.
If the case of the controller has to be removed for replacement/repair, contact your nearest Shimaden agent.

- ① Cut a hole for mounting the controller in the panel by referring to external dimensions and panel cutout in section 3-3.
- ② The panel thickness should be 1.0 – 3.5 mm.
- ③ The controller is provided with tabs for mounting. Insert as is from the front surface of the panel.
- ④ Controllers of the SRS10 Series are designed for mounting on the panel. Be sure to mount on the panel.
- ⑤ If mounted in series, provide ventilation so ambient temperature does not exceed 50°C due to temperature rise caused by heat generation.

3-3. External dimensions and panel cutout

SRS11

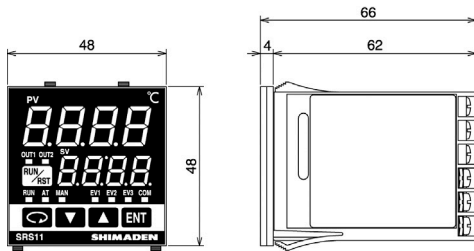

Panel cutout

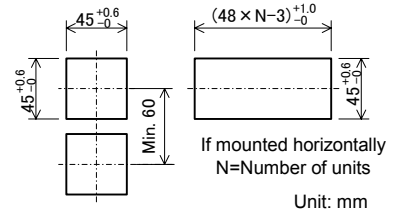

SRS13

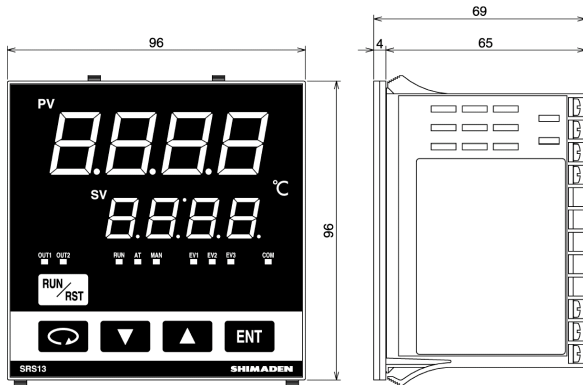

Panel cutout

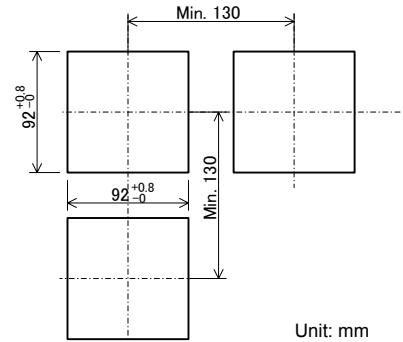

SRS14

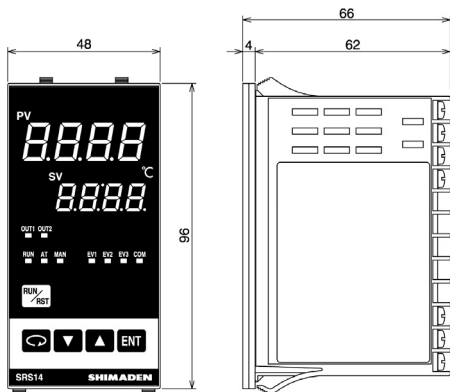

Panel cutout

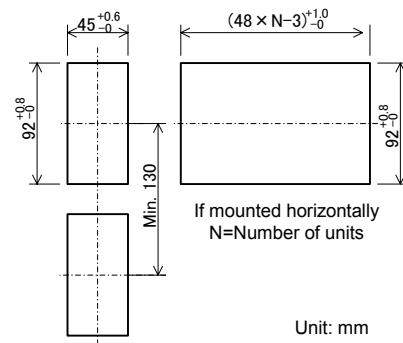

External dimensions of current detector for heater break alarm (CT)

0 ~ 30A (CTL-6-S)

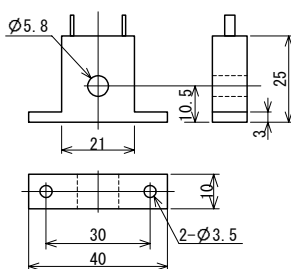

0 ~ 50A (CTL-12-S36-8)

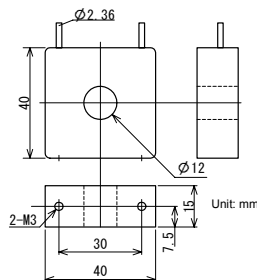

3-4 Wiring

⚠ CAUTION

- Be sure to turn off power before wiring. Failure to do so could result in electric shock.
- After wiring, do not touch terminal elements or other charged parts while conducting electricity. Failure to do so could result in electric shock.

Take the following precautions when wiring:

- ① Wire in accordance with the terminal layout of section 3-5 and the terminal arrangement table of section 3-6. After wiring, check and make sure the wiring is correct.
- ② Crimp-type terminals fit M3 screws. Use crimp-type terminals that are no wider than 6 mm.
- ③ For thermocouple input, use a compensating conductor that matches the type of thermocouple.
- ④ For R.T.D. input, resistance for lead wires should be a maximum of 5Ω per wire. All 3 wires should have the same resistance.
- ⑤ Input signal wires must not be accommodated with a strong electric circuit in the same conduit or duct.
- ⑥ Using shielded wiring (single point grounding) is effective for static induction noise.
- ⑦ Making input wiring short and twisting at regular intervals is effective for electromagnetic induction noise.
- ⑧ For power supply, use wiring or cable with sectional area of at least 1 mm² that offers the same performance as 600V vinyl insulated wiring.
- ⑨ Securely fasten the terminal element screw. Fastening torque: 0.5 N·m (5kgf·cm)
- ⑩ If the instrument appears to be easily affected by power supply noise, use a noise filter to prevent malfunctioning. Mount the noise filter on the grounded panel and make the wire connection between the noise filter output and power line terminals of the controller as short as possible.

Recommended noise filter:
DENISE-LAMBDA MAW-1202-22

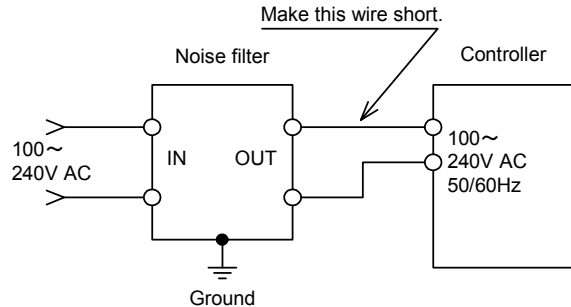

- ⑪ Current transformer (CT) connection method (CT input optional)

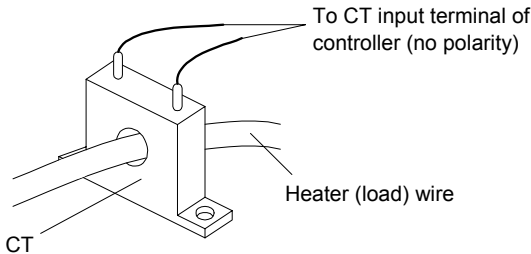

Pass one of the load lines through the dedicated CT hole. Wire from the CT secondary side terminal to the CT input terminal of the SRS10 Series. There are 2 combinations of CT connection terminals for the SRS10 Series, which can detect current for 2 heater combinations.

3-5. Terminal layout

Wire in accordance with the following terminal layout and terminal arrangement table.

SRS11

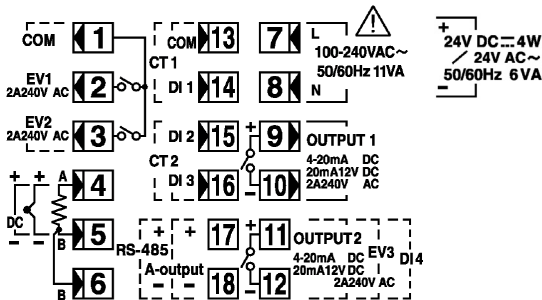

SRS13/SRS14

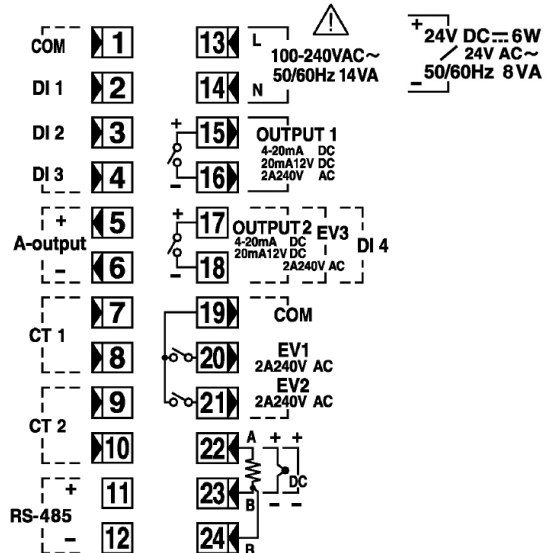

3-6. Terminal arrangement table

| Name of terminal | Description/code | Terminal No. | |
|--|--|--------------|----------|
| | | SRS11 | SRS13/14 |
| Power supply | 100-240V AC/24V AC:L,24V DC:+ 100-240V AC/24V AC:N,24V DC:- | 7 | 13 |
| | | 8 | 14 |
| Input | R.T.D: A, thermocouple / voltage / current: + R.T.D: B, thermocouple / voltage / current: - R.T.D: B | 4 | 22 |
| | | 5 | 23 |
| | | 6 | 24 |
| Control output 1 | Contact: NO, SSR drive voltage / voltage / current: + Contact: NO, SSR drive voltage / voltage / current: - | 9 | 15 |
| | | 10 | 16 |
| Control output 2 (optional) | Contact: NO, SSR drive voltage / voltage / current: + Contact: NO, SSR drive voltage / voltage / current: - | 11 | 17 |
| | | 12 | 18 |
| Event output (optional) | COM EV1 EV2 EV3 | 1 | 19 |
| | | 2 | 20 |
| | | 3 | 21 |
| | | 11-12 | 17-18 |
| CT input (optional) | CT1 input CT2 input | 13-14 | 7-8 |
| | | 15-16 | 9-10 |
| External control input / DI (optional) | COM DI1 DI2 DI3 DI4 | 13 | 1 |
| | | 14 | 2 |
| | | 15 | 3 |
| | | 16 | 4 |
| | | 11-12 | 17-18 |
| Analog output (optional) | + - | 17 | 5 |
| | | 18 | 6 |
| Communication (optional) | RS-485: + RS-485: - | 17 | 11 |
| | | 18 | 12 |

Note1: With thermocouple / voltage / current input, shorting across B and B terminal will cause an error.

Note2: The following optional function of the SRS10 Series are limited to exclusive selection.

SRS11: Only one among control output 2, event output 3 and external control input DI4 can be selected.
Either CT input or external control input DI1 - 3 can be selected.
Either analog output or communication can be selected.

SRS13: Only one among control output 2, event output 3 and external control input DI4 can be selected.
SRS14

3-7. Operation preparations

Before operating the controller, you should first check the wiring and carry out the following by screen group setting method. There is however no need to change the settings that have been set at the factory or already been made by the manufacturer.

1. Wiring check

Make sure the wiring to the connection terminals is correct. Incorrect wiring could result in burnout.

2. Power ON

Turn on the operating power. The displays, etc., light when power is supplied to the controller.

3. Measuring range setting

Select code from Measuring Range Codes of "4-57 Measuring range codes setting screen" of 1 screen group and enter.

Select temperature unit of "4-58 Input unit setting screen" of 1 screen group and enter.

For current, voltage and mV input, set lower limit value, higher limit value and position of decimal point of display contents for input signal.

(You should also select by 4-59, 4-60 and 4-61 screens by code.)

4. Control mode (PID) setting

For ON-OFF (2 position) action, select OFF by "2-1. Output 1 PID1 proportional band setting screen" of 2 screen group and enter.

Sets hysteresis by "2-2. Output 1 PID1 hysteresis setting screen."

If equipped with output 2, set by same method.

If using auto tuning (AT) with other than ON-OFF hysteresis, this setting operation is not required.

5. Control output characteristics setting

Select RA (for heating) or DA (for cooling) according to output specification (heating/cooling) on "4-45 Output 1 output characteristics setting screen" and "4-48 Output 2 output characteristics setting screen" of 4 screen group and enter.

6. Event type setting

If equipped with event, select types of event on "4-2, 4-7 and 4-12 Event type setting screen" of 4 screen group and enter.

7. Analog output setting

If equipped with analog output, select items to be output as analog signals on "4-23 Analog output type setting screen" of 4 screen group and enter.

8. Precaution concerning initialization by data modification

Modifying measuring range code, type of event or type of analog output initializes related setting values (data). The data must therefore be set again.

4. Names and functions of parts on front panel

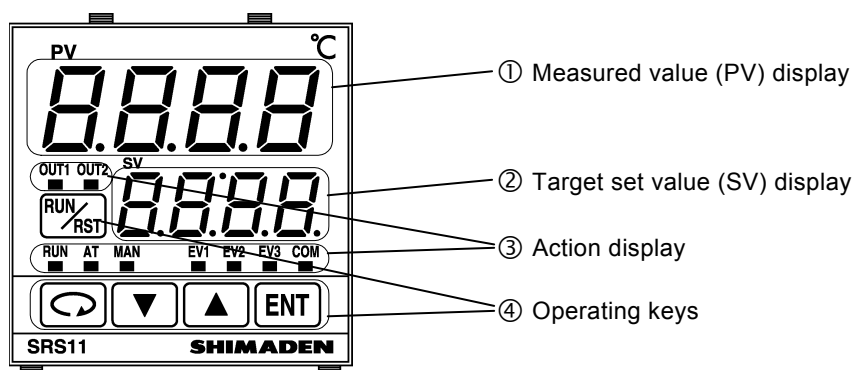

| Name | Function |
|---------------------------------|---|
| ① Measured value (PV) display | (1) Measured value display LED (red) * Displays current PV value on basic screen (screen 0-0). * Displays type of parameter on each respective parameter display screen. |
| ② Target set value (SV) display | (2) Target value display LED (green) * Displays current PV value on basic screen (screen 0-0). * Displays setting values on each respective parameter setting screen. |
| ③ Action display | Displays status of controller. * RUN: Action display LED (green) Off: Standby or reset On: Running by fixed value control Flashing: Running by program * AT : Auto tuning LED (green) Off: Auto tuning not executed On: Auto tuning standby Flashing: Auto tuning being executed * MAN: Manual control LED (green) Off: Output by automatic control. Flashing: Output by manual control. * OUT1: Control output 1 (green) * OUT2: Control output 2 (green) For output by contact or SSR drive voltage: Off: Output is OFF. On: Output is ON. For voltage/current output: Brightness changes according to the output ratio. (Light brightly if output is 100% and dimly if output is 0%.) * EV1: Event output 1 (orange) * EV2: Event output 2 (orange) * EV3: Event output 3 (orange) Off: Event output is OFF. On: Event output is ON. Note: Always off if event output is not selected as an optional item. * COM: Communications mode (green) Off: Communications local mode On: Communications COM mode |
| ④ Operating keys | * : Parameter key Displays the next screen in various screen groups Pressing and holding for at least 3 seconds on 0-0 screen displays 4-0 initial settings screen group. * : Down key Decrements setting values. * : Up key Increments setting values. * : Enter key Enters setting values. Displays various screen groups if no SV values are being modified on the basic screen. * : RUN/RST key Pressing and holding for at least 2 seconds in STBY (RST) status switches to EXE (RUN). Pressing and holding for at least 2 seconds during EXE (RUN) switches to STBY (RST) status. Fixed value control (FIX mode) STBY: Standby status EXE: Control execution status Program control (PROG mode) RST: Reset status RUN: Program execution status |

5. Parameter diagram and setting

5-1 Parameter diagram

The overview of the parameter diagram is as follows. The windows of the various screens are divided as follows. The number at the top left of the window is the screen No.

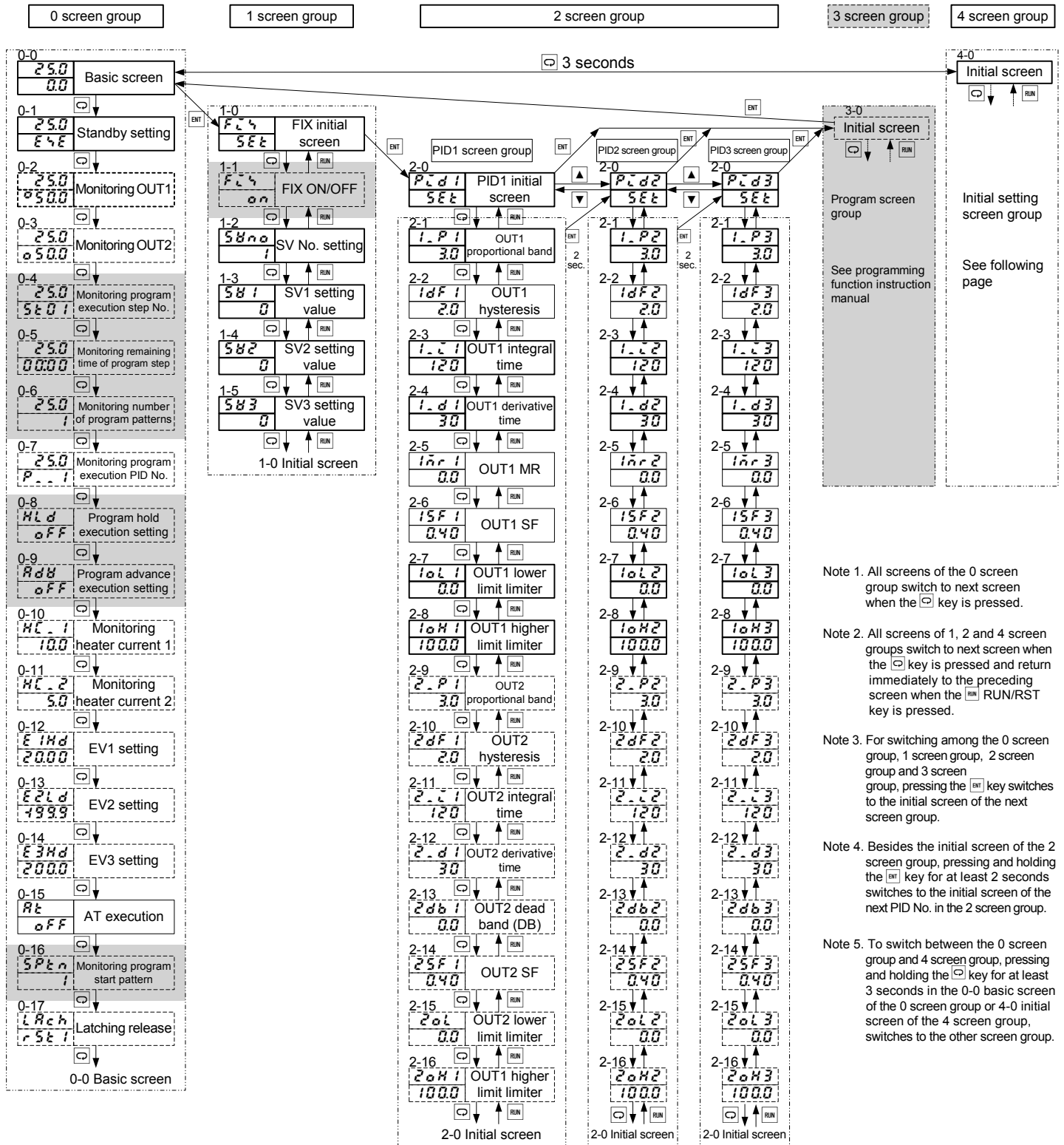
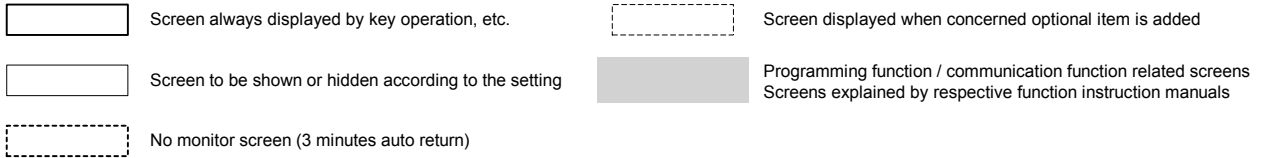

- Note 1. All screens of the 0 screen group switch to next screen when the **ENT** key is pressed.
- Note 2. All screens of 1, 2 and 4 screen groups switch to next screen when the **ENT** key is pressed and return immediately to the preceding screen when the **RUN/RST** key is pressed.
- Note 3. For switching among the 0 screen group, 1 screen group, 2 screen group and 3 screen group, pressing the **ENT** key switches to the initial screen of the next screen group.
- Note 4. Besides the initial screen of the 2 screen group, pressing and holding the **ENT** key for at least 2 seconds switches to the initial screen of the next PID No. in the 2 screen group.
- Note 5. To switch between the 0 screen group and 4 screen group, pressing and holding the **ENT** key for at least 3 seconds in the 0-0 basic screen of the 0 screen group or 4-0 initial screen of the 4 screen group, switches to the other screen group.

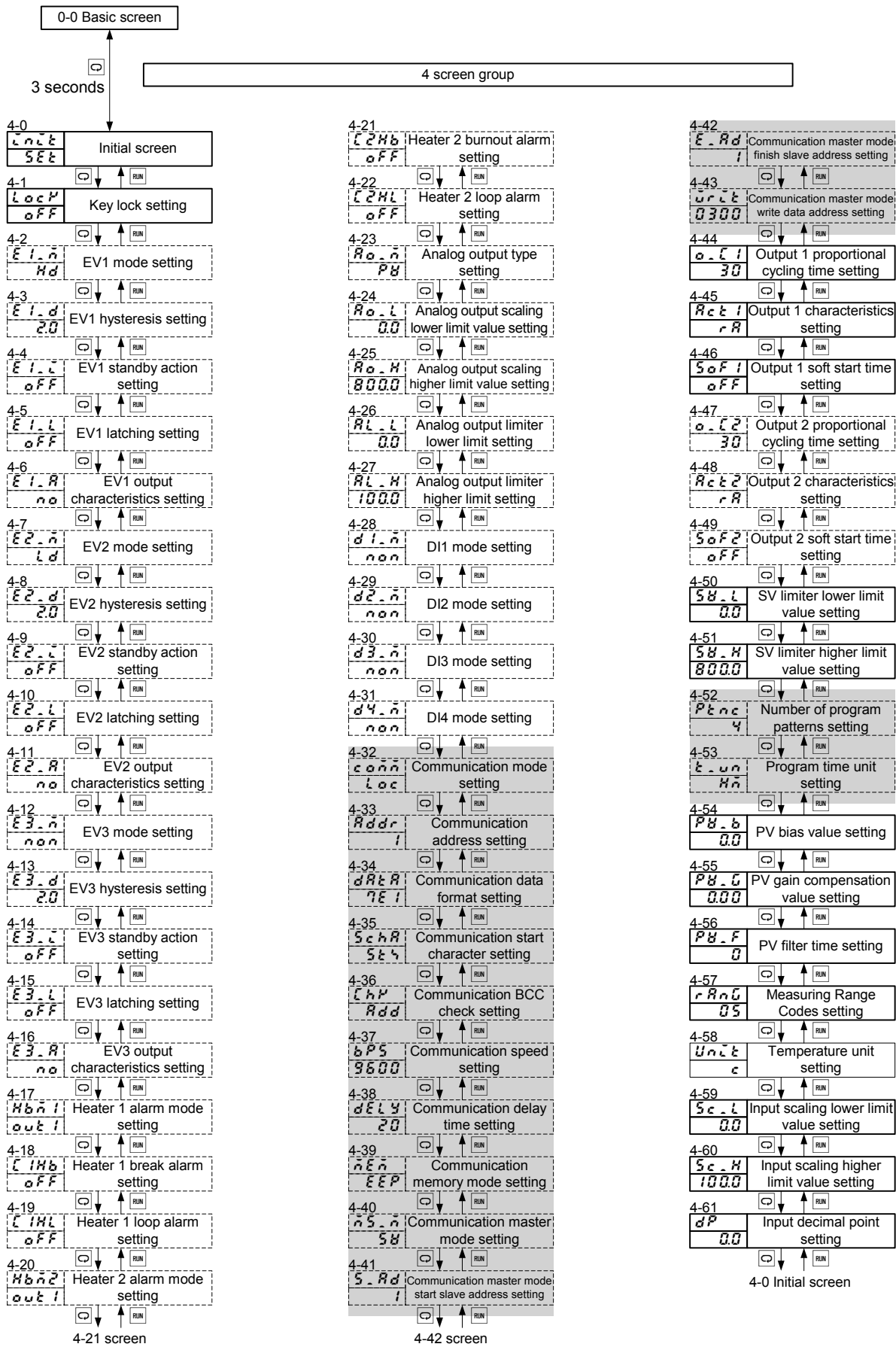

5-2. Display when power is applied

When power is applied, the initial screen when power is applied displays each screen for about 1 sec. and switches to the basic screen of screen group 0 as shown in the following figure.

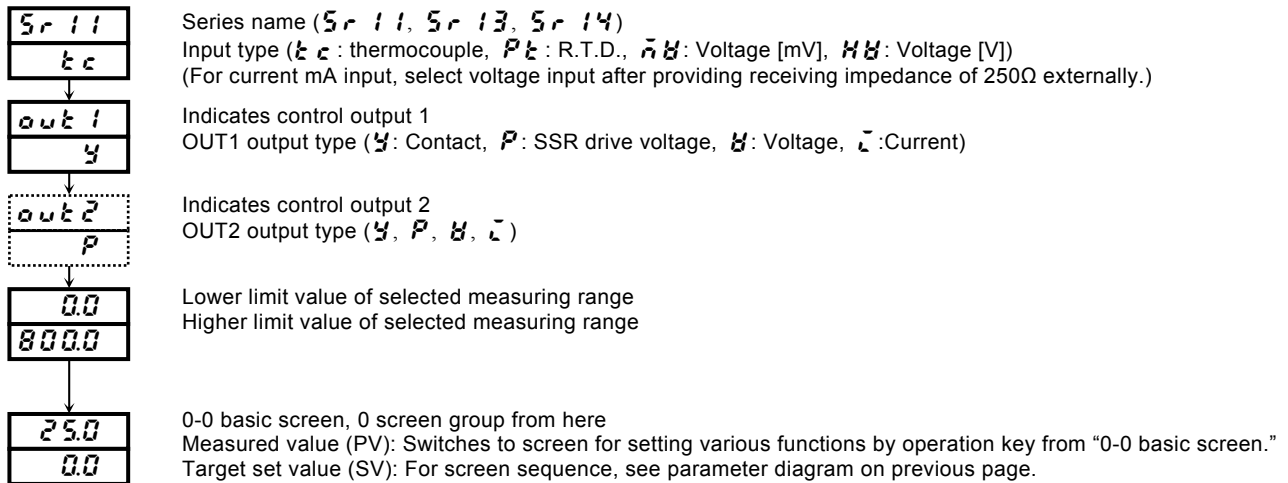

5-3. Switching screens

Within 0 screen: Screen group primarily set by end users.

Screen group 1: Target set value setting screen group (multi SV).

Screen group 2: Screen group that sets PID constant.

Screen group 3: Displayed if equipped with programming function (optional). See "Programming Function Instructions."

Screen group 4: Screen group primarily set by manufacturer / equipment maker. (Initial setting screen group)

(1) Switching screens within screen group 0

Each time the key is pressed the screen display switches to the next screen. If pressed when the last screen is displayed, returns to the 0-0 basic screen.

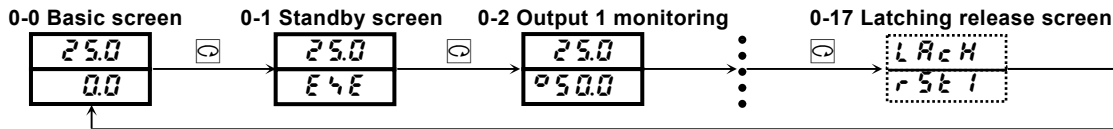

(2) Switching between screen group 0 and screen group 1

Pressing the key on the basic screen of screen group 0 switches to "1-0 initial screen" of screen group 1.

Pressing the key on the "1-0 initial screen" of screen group 1 switches to the initial screen of screen group 2.

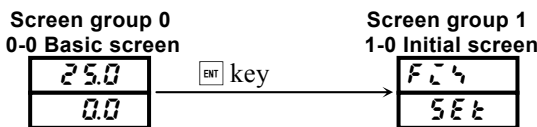

(3) Switching screens within screen group 1

Each time the key is pressed on the "1-0 initial screen" in screen group 1, the screen display switches to the next screen. If pressed when the last screen is displayed, returns to the "1-0 initial screen."

With screen group 1, each time the key is pressed, the screen is switched in the reverse direction.

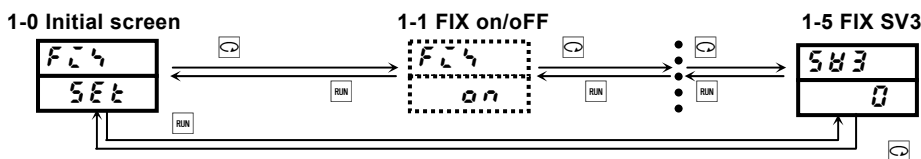

(4) Switching to screen group 2

Pressing the **ENT** key on the “1-0 initial screen” switches to the “2-0 initial screen” of screen group 2.

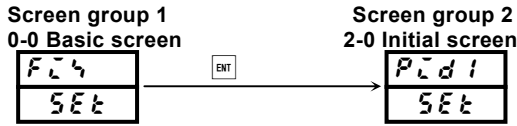

(5) Switching screens within screen group 2

The “2-0 initial screen” in screen group 2 is the PID1 setting initial screen. Each time the **▲** key is pressed, the setting initial screen switches PID2→PID3→PID1. Pressing the **▼** key switches PID1→PID3→PID2.

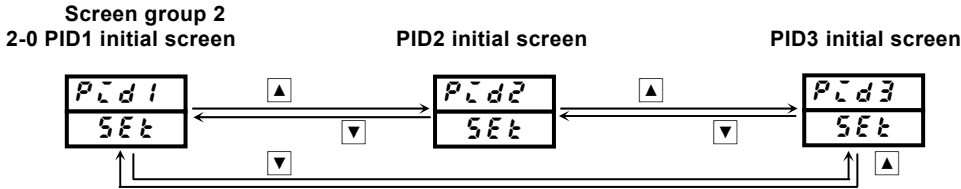

Each time the **☐** key is pressed the screen display switches from the various initial screens to the next screen. If pressed when the last screen is displayed, returns to the “2-0 initial screen.”

With screen group 2, each time the **RUN** key is pressed, the screen is switched in the reverse direction.

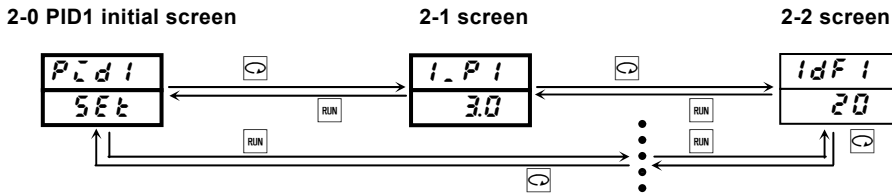

(6) Switching to screen group 3

Screen group 3 is the program screen group. It is not displayed unless it is set as an optional item.

Pressing the **ENT** key on the “2-0 initial screen” switches to the “3-0 initial screen” of screen group 3. Further pressing the **ENT** key switches to the basic screen.



For more information on the programming function, see the “Programming Function Instructions.”

(7) Switching to screen group 4

Screen group 4 is the initial setting screen group. Various settings are made prior to using the controller. Pressing the **☐** key on the basic screen of screen group 0 for at least 3 seconds switches to “4-0 initial screen” of screen group 4. Pressing the **☐** key on the “4-0 initial screen” of screen group 4 for at least 3 seconds switches to the basic screen of screen group 0.

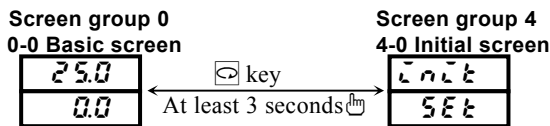

(8) Switching screens within screen group 4

Each time the **☐** key is pressed screen display switches from the initial screens to the next screen. If pressed when the last screen is displayed, returns to the “4-0 initial screen.”

With screen group 4, each time the **RUN** key is pressed, the screen is switched in the reverse direction.

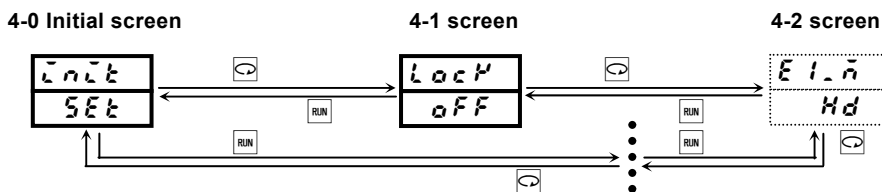

(9) Set data modification

Data is modified on the various screens by pressing the **▲** or **▼** key. The modified data is entered by pressing the **ENT** key.

5-4. Auto return function

If no key operation is conducted for 3 minutes on the various screens (with the exception of the “0-2 output 1 monitoring screen”, “0-3 output 2 monitoring screen”, “0-4 step No. monitoring screen”, “0-5 remaining time of step monitoring screen”, “0-6 number of pattern execution monitoring screen”, “0-7 Execution PID No. monitoring screen”, “0-10 heater current 1 monitoring screen” or “0-11 heater current 2 monitoring screen”), the mode automatically returns to the “0-0 basic screen” of screen group 0 (auto return).

5-5. Screen group 0 setting

The flow is given in “6. Screen description and setting items.” This section however primarily contains a description of how to make settings.

As for the key operation method, the key switches to the next screen. The settings are selected with the key or key on the various setting screens and entered with the key.

Pressing the key is however not required for modifying output values on the output monitoring screen for manual adjustment.

(1) Setting target set values (SV)

- To set target set values (SV), press the key or key on the “0-0 basic screen.” Pressing and holding the key causes the decimal point of the lowest digit to flash, and the value is incremented or decremented. When the desired target set value is reached, enter by pressing the key.
- When the setting is entered, the decimal point of the lowest digit of the target set value stops flashing. Target values cannot be set while auto tuning (AT) is being executed. To set target values, you must first cancel auto tuning.

Example: Set target set value to 500.0°C.

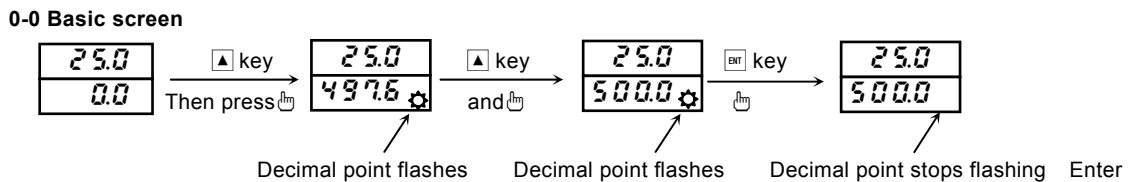

(2) Manual setting of control output

1) Output monitoring screen (OUT1/OUT2) and switching and setting automatic/manual output

To toggle between automatic and manual, press and hold the key on the “0-2 output 1 monitoring screen” or “0-3 output 2 monitoring screen” or press the key and keys simultaneously.

During manual output, the MAN lamp flashes and it goes off during the automatic output operation.

Pressing the key or key on the output monitoring screen during manual output enables you to set the manual output values.

To return to automatic output, press and hold the key for 3 seconds or press the and keys simultaneously.

- Changing output action of either output 1 or output 2 to manual automatically changes the other to manual. Similarly, changing one to auto also automatically changes the other to automatic as well.
- If output of output 1 is 100.0%, is displayed on the output 1 monitoring screen and the decimal point of flashes.
- If output of output 2 is 100.0%, is displayed on the output 2 monitoring screen and the decimal point of flashes.
- If output is contact or SSR drive voltage and the proportional band (P) setting is OFF, the output value is 0.0% or 100.0%.
- If output is voltage or current and the proportional band (P) setting is OFF, the output value is the lower limit value or higher limit value of the output limiter set.

NOTE1: Manual output cannot be changed while automatic tuning (AT) is being executed. To change, you must first cancel AT.

NOTE2: If MAN is selected in “4-28 – 4-31 DI mode setting screen”, external control input has a priority and manual output change cannot be conducted in 0-1 screen.

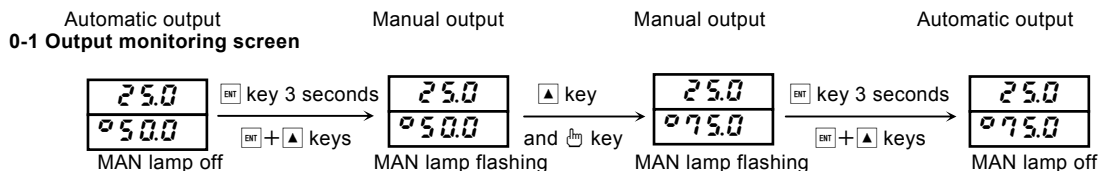

2) Supplementary explanation for use of manual control output

The correlation of the “0-2 output 1 monitoring screen” and “0-3 output 2 monitoring screen” and automatic/manual output is as follows:

- Output when automatic output is changed to manual is balanceless bumpless action, and the output value prior to change value is displayed.

When manual is changed to automatic, it becomes bumpless action except if measured value (PV) is outside the proportional band.

- If power supply is cut off and turned back on, control output action continues in automatic or manual mode, whichever was set when the power was shut off.

Note: You can switch to another screen in the manual mode as well, but you should note that control output is also manual mode.

When the MAN monitor LED is flashing, the controller is in manual mode.

- Manual output (MAN) is canceled in the following cases:

When range, input unit, input scaling higher limit or input scaling lower limit is modified.

(3) Auto tuning (AT)

Function that automatically processes and sets parameter PID for PID control. Processing time varies according to control.

1) AT execution

Pressing the \blacktriangle key on the “0-15 AT action control screen” causes the *oFF* display at the bottom to change to *o n* and the decimal point of the smallest digit to flash.

Pressing the \square key then executes AT. The decimal point stops flashing and the AT lamp flashes.

When AT is executed, ON/OFF hysteresis of output is repeated several times according to increment or decrement of measured values. The PID value is saved in the internal memory and the action ends. Control based on the PID value in the memory simultaneously starts and the AT lamp stops flashing.

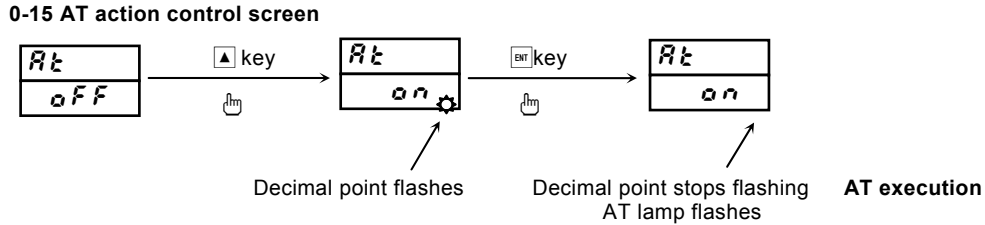

2) Cancellation of AT

To cancel AT before it finishes, select \blacktriangledown with the *oFF* key on the “0-15 AT action control screen.” When the \square key is pressed, AT is cancelled. The decimal point and the AT lamp then stop flashing.

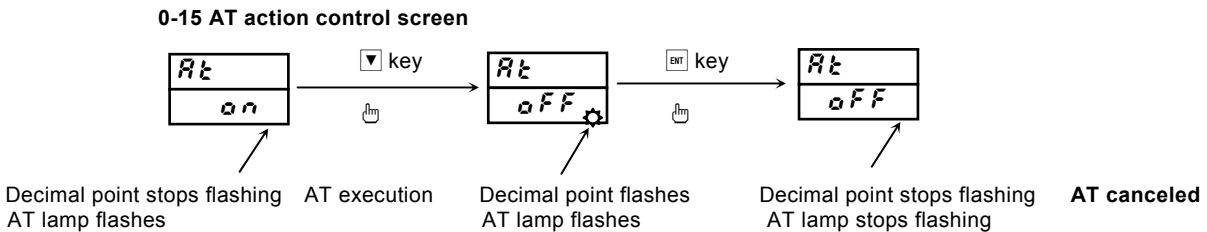

Note: If AT is canceled before completion, PID value is not changed.

3) AT cannot be executed

AT cannot be executed under any of the following conditions:

- ① Control output is manual. (AT screen not displayed)
- ② Standby (AT screen not displayed)
- ③ Measured value (PV) is scaleover. (AT screen not displayed)
- ④ Control output 1 proportional band (P) is OFF. (AT screen not displayed)
- ⑤ If lock No. 2 or 3 is set on the key lock screen.

4) AT cancellation during execution

AT is canceled during execution under any of the following conditions:

- ① If 200 continuous minutes elapse while output value is 0% or 100%.
- ② When PV is scaleover.
- ③ When switched to standby action.

5) AT action for 2-output specifications

With 2-output specifications, AT action changes according to RA/DA characteristics as follows:

- ① When OUT1/2 characteristics differ (RA/DA or DA/RA)
PID constant is same value for both output 1 and output 2.
- ② RA characteristics for both OUT1/OUT2 or DA characteristics for both OUT1/OUT2
AT action is executed for output 1 only; OUT2 during AT execution is 0% output or output limiter lower limit value.

NOTE: During AT execution, any setting change cannot be conducted except for cancellation of AT, change to standby mode, key rock setting and change of transmission mode.

(4) Standby (STBY) / execution (EXE)

The controller is equipped with a standby mode for temporarily halting controller execution. This operation mode is switched on the “0-1 standby action setting screen.”
 In the case of fixed value control (FIX mode), STBY (standby) / EXE (execution) is displayed.
 In the case of program control (PROG mode), RST (reset: stop) / RUN (program execution) is displayed.

If EXE1 (RUN1) or EXE2 (RUN2) is selected on the “4-28 – 4-31 DI mode setting screen”, external control input (DI) is given priority and settings cannot be made on the 0-3 screen.

- ① The RUN lamp is lit green while the controller is operating and it goes off during standby.
- ② **Controller output for standby is 0%.**
- ③ When standby is executed, auto tuning (AT) is canceled.
- ④ When standby is executed in the manual input mode, the manual input mode is canceled.
- ⑤ When the power is turned off while the controller is in standby mode, standby mode continues when the power is turned back on.
- ⑥ If event standby action is specified when switching to execution mode (EXE) from standby mode (StbY), the specified standby action is executed.
- ⑦ If event latching is not engaged in the standby mode, alarms (Hd, Ld, od, id, HA, LA) are not output.

(5) Event setting

Types of event must be set before setting event values.
 Modifying the types of event code however initializes setting values (data) related to events.

1) Types of event (alarm type) setting

Select type code from among Hd, Ld, od, id, HA, LA, So, EXE(run), HC1, HC2, StPS, PtnS, EndS, hoLd, ProG, u_SL, d_SL on the “4-2 event 1 type setting screen of screen” group 4 with the \blacktriangle key / \blacktriangledown key and enter the event type with the $\boxed{\text{ENT}}$ key.
 Set event 2 and event 3 on the “4-7 event 2 type setting screen” and “4-12 event 3 type setting screen” in the same manner.
 The types of event for which event values can be set are the following 6 types:

Event type (alarm type) code: Hd: higher limit deviation, Ld: lower limit deviation,
 od: outside higher/lower limit deviation, id: inside higher/lower limit deviation,
 HA: higher limit absolute value, LA: lower limit absolute value

If none, So: scaleover, EXE: EXE signal (run: RUN signal), HC1: heater 1 break/loop alarm, or HC2: heater 2 break/loop alarm is selected, event values cannot be set.

2) Event values setting

Event values are set on the “0-12 event 1 setting values setting screen”, “0-13 event 2 setting values setting screen” and “0-14 event 3 setting values setting screen.” Type of event is displayed when one of the previously mentioned 6 types of events is selected.
 Event values are set by selecting setting range by pressing the \blacktriangle key / \blacktriangledown key on the 0-12, 0-13 or 0-14 screen.
 When the event value setting has been decided, enter by pressing the $\boxed{\text{ENT}}$ key and the decimal point stops flashing.

| | |
|--|------------------------|
| Setting range: Higher limit deviation or lower limit deviation | -1999 – 2000 unit |
| Outside or inside higher/lower limit deviation | 0 – 2000 unit |
| Higher limit absolute value or lower limit absolute value | Within measuring range |

Event values cannot be set during auto tuning (AT) execution. AT must first be canceled.

0-5 event 1 setting values setting screen

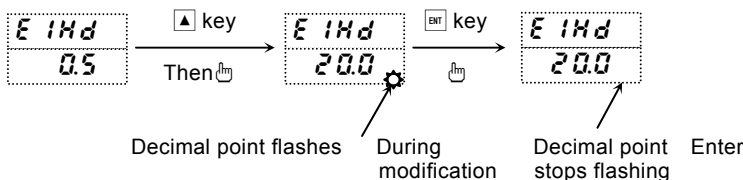

(6) Multi SV (target set values)

1) Multi SV

You can set 3 types of target set values (SV). (SV1, SV2, SV3)
 SV values are set on the “1-3 – 1-5 FIX control SV1 – SV3 setting screen” and execution SV No. is selected on the “1-2 execution SV No. selection screen.”
 PID No. during multi SV is SV1/PID1, SV2/PID2 and SV3/PID3.

2) External selection switching of multi SV

If equipped with external control input DI, if ESV2 is allocated to DI, execution SV can be selected from among SV1 – SV3 by DI input.
 Using 2 points of DI, DI to be used for SV selection is allocated on “4-28, 4-29 DI1 and DI2 mode setting screen.”
 See “8-4. External control input (DI) .”

6. Screen explanation and setting items

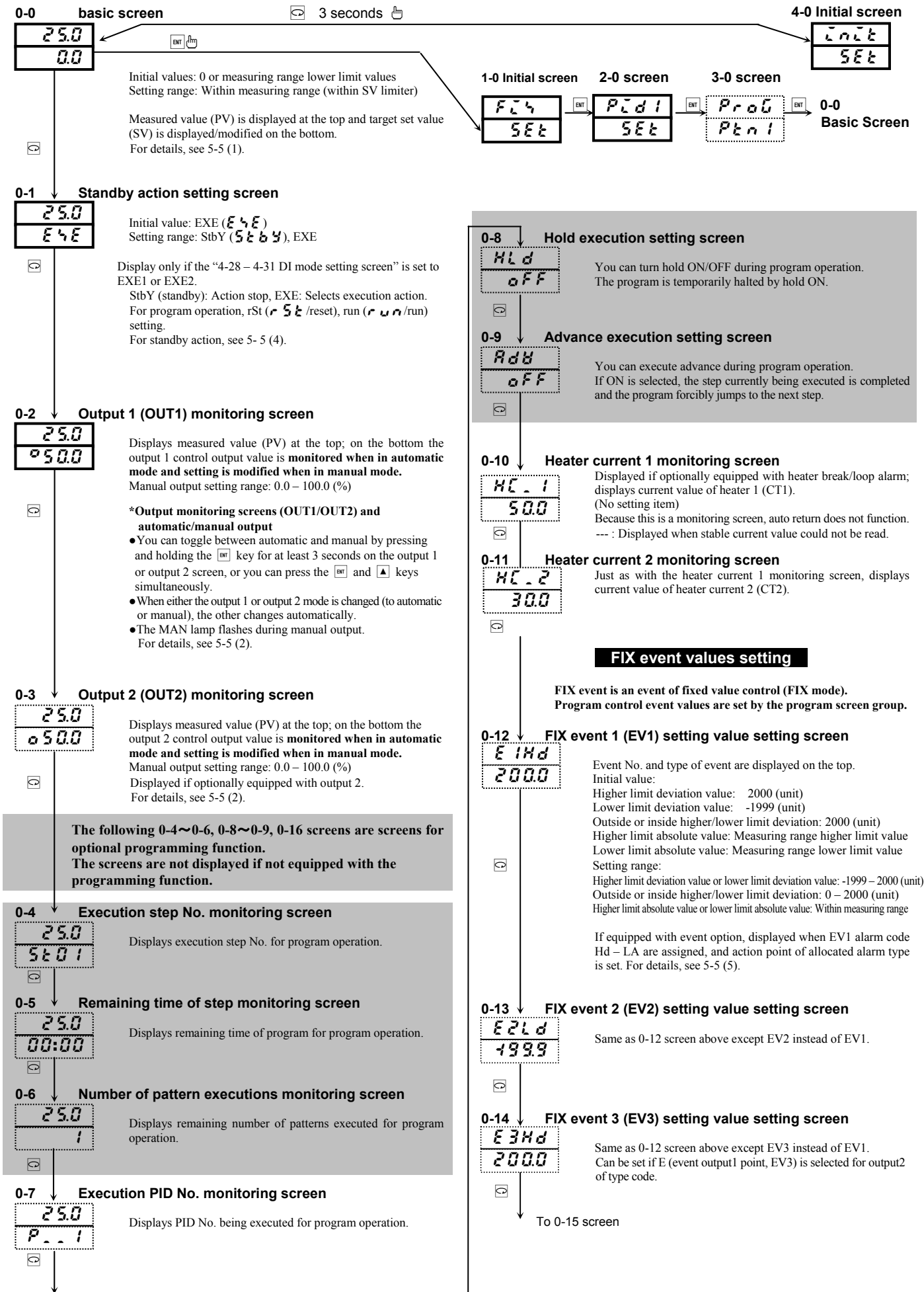

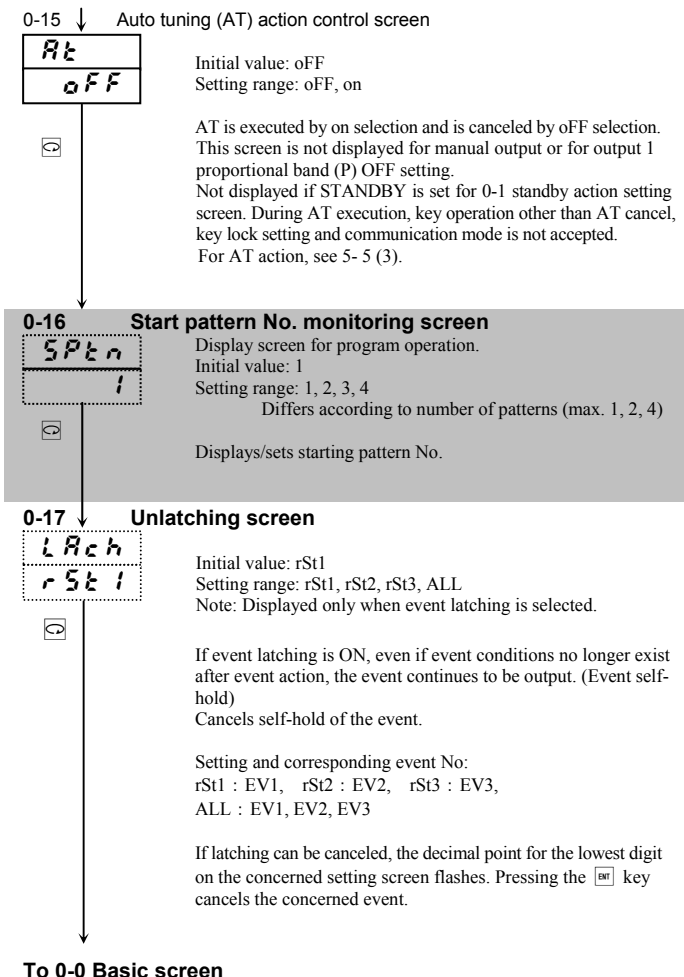

FIX control (fixed value control) setting

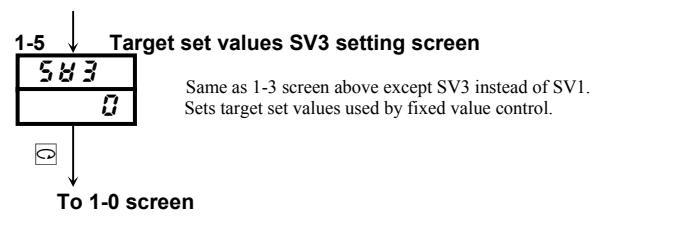
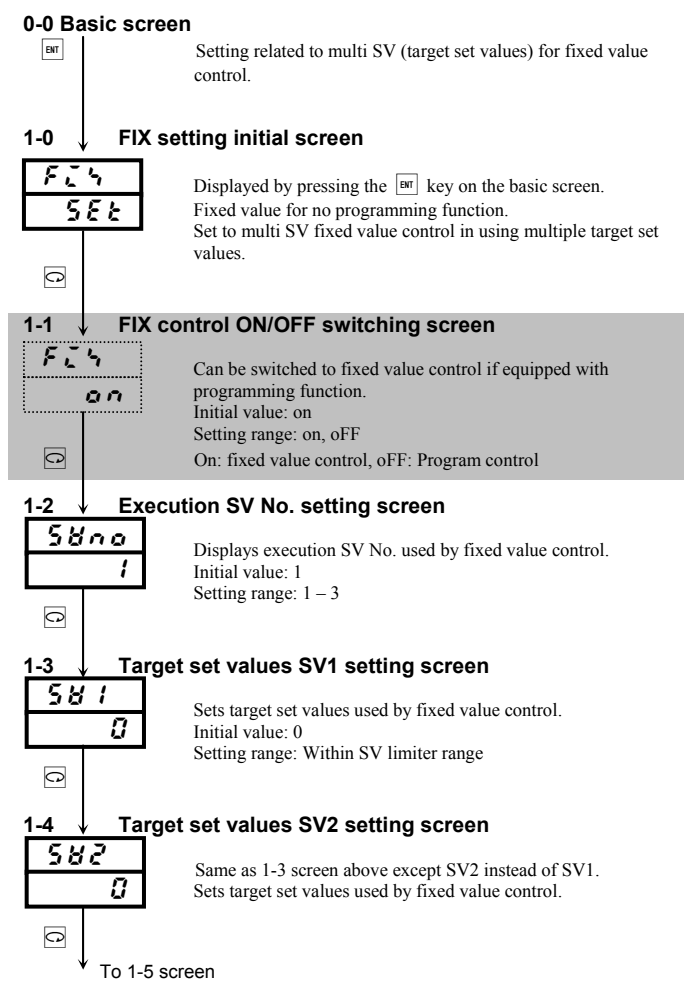

PID setting

PID setting screen group
With the SRS10 Series, you can have 3 types of PID constants. In the case of fixed value control (FIX), target set values SV1, SV2 and SV3 correspond to PID1, PID2 and PID3 respectively. In the case of program control, an execution PID No is allocated to each step.

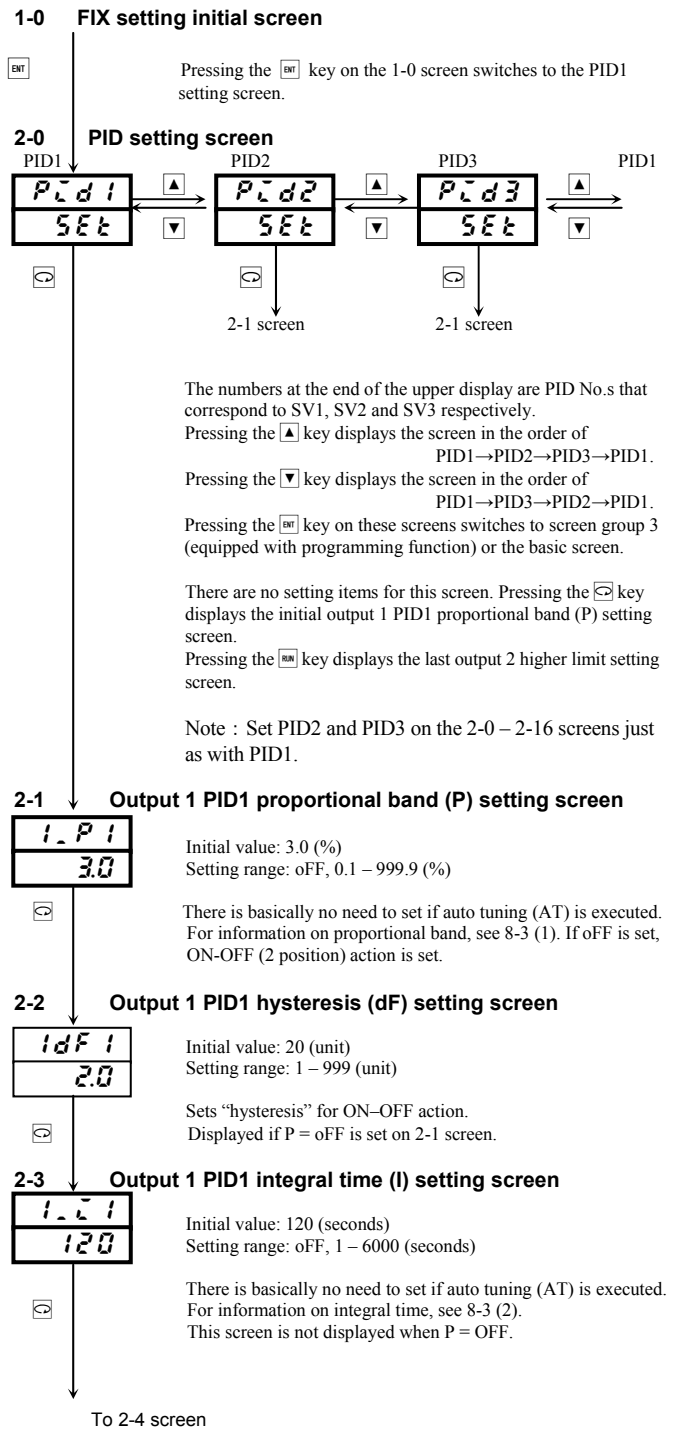

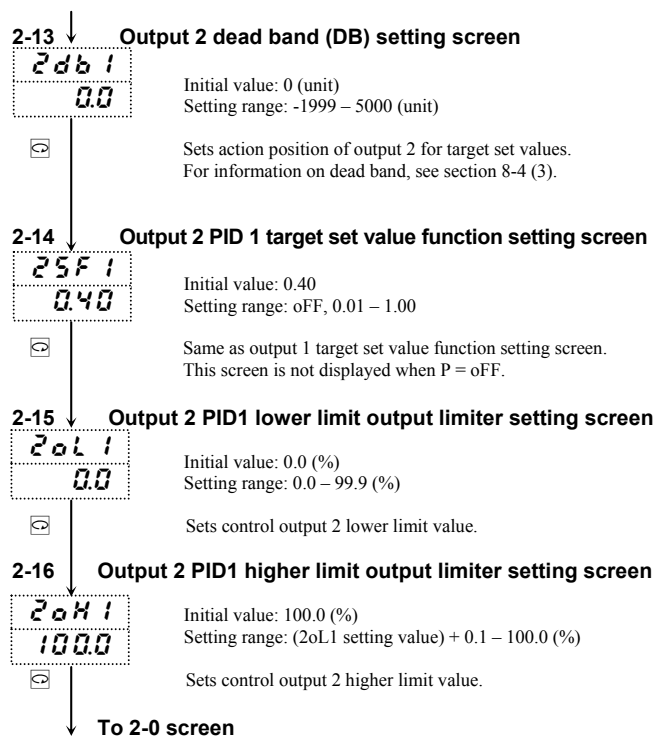
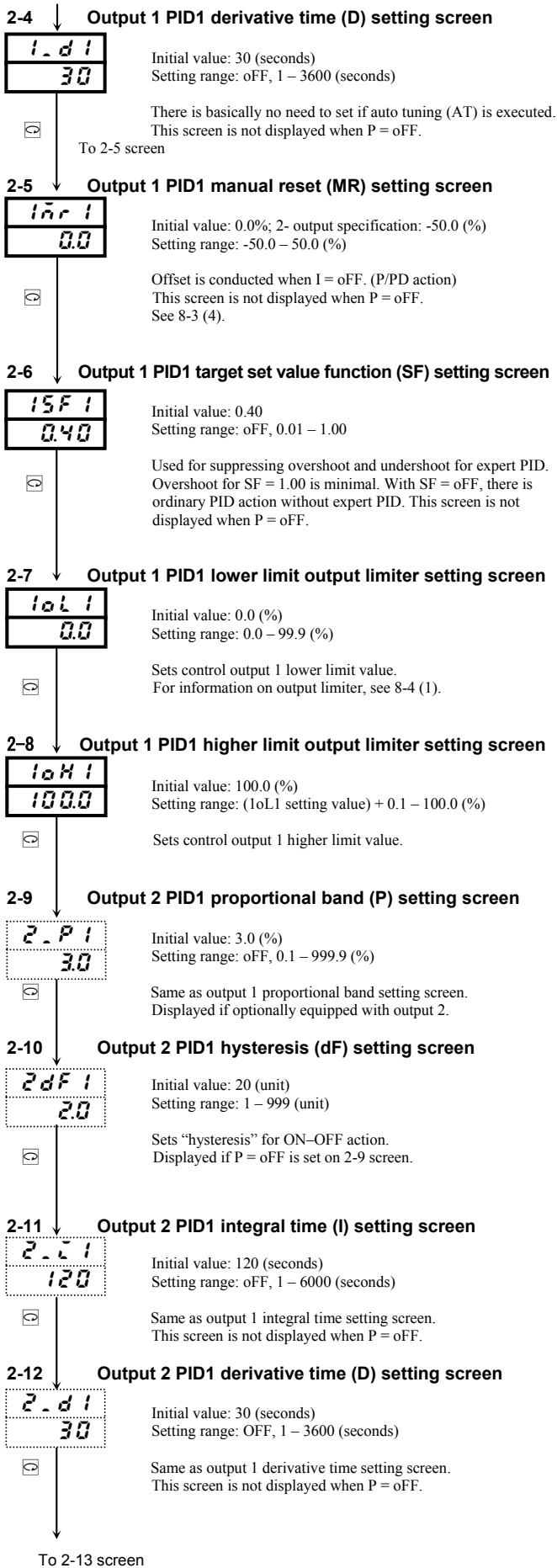

Initial settings screen

Initial settings screen group (screen group 4)

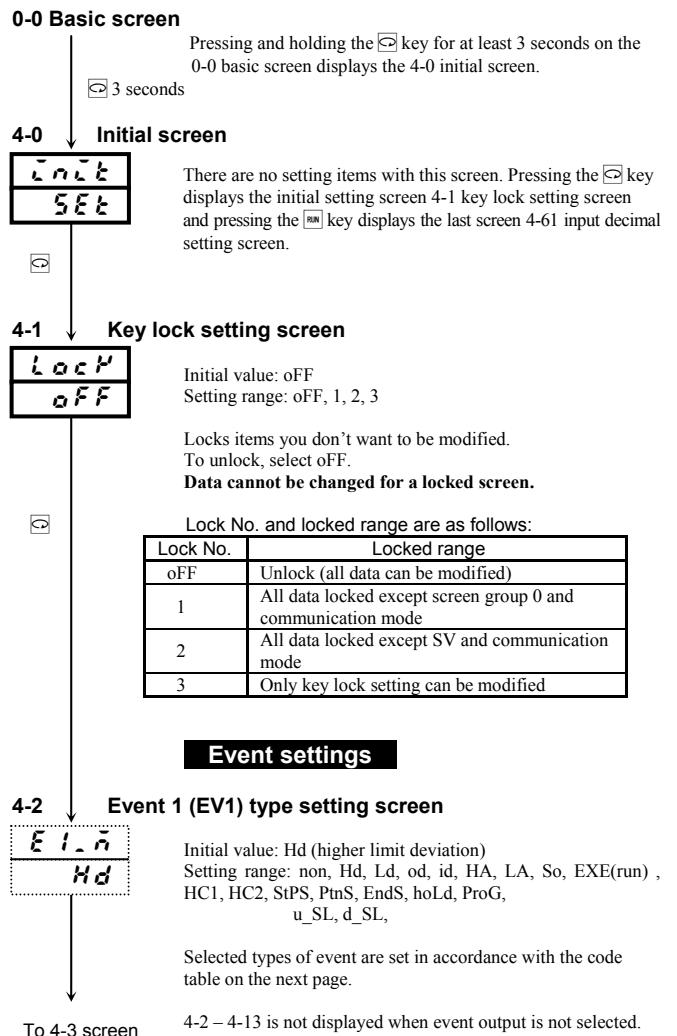

Event settings

Event type code (used by 4-7 and 4-12)

| Code | Types of event | Remarks |
|-------------|---|-------------------------------|
| non (non) | No selection | |
| Hd (Hd) | Higher limit deviation | EV1 initial values |
| Ld (Ld) | Lower limit deviation | EV2 initial values |
| od (od) | Outside higher/lower limit deviation | |
| id (id) | Inside higher/lower limit deviation | |
| HA (HA) | Higher limit absolute value | |
| LA (LA) | Lower limit absolute value | |
| So (So) | Scaleover | |
| EXE (EXE) | EXE signal (fixed value control being executed) | For fixed value control only |
| run (run) | RUN signal (program being executed) | For program control only |
| HC1 (HC1) | Heater 1 break/loop alarm | Only when optionally equipped |
| HC2 (HC2) | Heater 2 break/loop alarm | Only when optionally equipped |
| StPS (StPS) | Step signal | For program control only |
| PtnS (PtnS) | Pattern signal | For program control only |
| EndS (EndS) | Program end signal | For program control only |
| HoLd (HoLd) | Hold signal | For program control only |
| ProG (ProG) | Program signal | For program control only |
| u_SL (u_SL) | Up slope signal | For program control only |
| d_SL (d_SL) | Down slope signal | For program control only |

4-3 Event 1 action hysteresis setting screen

E1.d
2.0

Initial value: 20 (unit)
Setting range: 1 – 999 (unit)

Sets ON-OFF hysteresis for event 1.
Displayed when alarm type code is **Hd, Ld, od, id, HA, LA, HC1, or HC2**.

4-4 Event 1 standby action code setting screen

E1.L
oFF

Initial value: oFF
Setting range: oFF, 1, 2, 3

Sets type of standby action for event 1 from code table.
Displayed when alarm type code is **Hd, Ld, od, id, HA, LA, HC1, or HC2**.

Standby action code (used by 4-9 and 4-14)

| Code | Description of standby action |
|------|--|
| oFF | No standby |
| 1 | When power is applied, STBY(RST) → EXE(RUN) |
| 2 | When power is applied, STBY(RST) → EXE(RUN), SV modification |
| 3 | Control mode (no standby) |

For HC1/HC2, only oFF or 1 can be selected.
Standby action only when power is applied.

4-5 Event 1 latching setting screen

E1.L
oFF

Initial value: oFF
Setting range: oFF, on

oFF: Latching function disabled
on: Latching function enabled

With the event latching function, the event continues to be output even if there are no event conditions after event action. (Event self-hold)
Displayed when alarm type code is **Hd, Ld, od, id, HA, LA, HC1, HC2**.

4-6 Event 1 output characteristics setting screen

E1.R
no

Initial value: no
Setting range: no, nc

no: Normally open (output conductivity for event ON)
nc: Normally closed (output conductivity for event OFF)

Selects whether contact output for event action is conductive or nonconductive.
Event output for power OFF is nonconductive for both no and nc.

4-7 Event 2 (EV2) type setting screen

E2.n
Ld

Initial value : Ld (lower limit deviation value)
Setting range: non, Hd, Ld, od, id, HA, LA, So, EXE (run), HC1, HC2, StPS, PtnS, EndS, HoLd, ProG, u_SL, d_SL,

Types of events selected for EV2 are set from the **event type code table of 4-2** just as with EV1.

To 4-8 screen

4-8 Event 2 action hysteresis setting screen

E2.d
2.0

Initial value: 20 (unit)
Setting range: 1 – 999 (unit)

Sets ON-OFF hysteresis of event 2 just like EV1.
Displayed when alarm type code is **Hd, Ld, od, id, HA, LA, HC1, or HC2**.

4-9 Event 2 standby action code setting screen

E2.L
oFF

Initial value: oFF
Setting range: oFF, 1, 2, 3

Sets type of standby action for event 2 from the standby **action code table of 4-4** just like EV1.
Displayed when alarm type code is **Hd, Ld, od, id, HA, LA, HC1, or HC2**.
For HC1/HC2, only oFF or 1 can be selected.

4-10 Event 2 latching setting screen

E2.L
oFF

Initial value: oFF
Setting range: oFF, on

Set just like EV1.

4-11 Event 2 output characteristics setting screen

E2.R
no

Initial value: no
Setting range: no, nc

Set just like EV1.

4-12 Event 3 (EV3) type setting screen

E3.n
non

Initial value: EXE (run)
Setting range: non, Hd, Ld, od, id, HA, LA, So, EXE(run), HC1, HC2, StPS, PtnS, EndS, hoLd, ProG, u_SL, d_SL,

Types of events selected for EV3 are set from the **event type code table of 4-2** just as with EV1.
4-12 – 4-16 screen is displayed if control output2 is selected as event output (EV3).

4-13 Event 3 action hysteresis setting screen

E3.d
2.0

Initial value: 20 (unit)
Setting range: 1 – 999 (unit)

Sets ON-OFF hysteresis of event 3 just like EV1.
Displayed when alarm type code is **Hd, Ld, od, id, HA, LA, HC1, or HC2**.

4-14 Event 3 standby action code setting screen

E3.L
oFF

Initial value: oFF
Setting range: oFF, 1, 2, 3

Sets type of standby action for event 3 from the **standby action code table of 4-4** just like EV1.
Setting conditions are same as for EV1.

4-15 Event 3 latching setting screen

E3.L
oFF

Initial value: oFF
Setting range: oFF, on

Set just like EV1.

4-16 Event 3 output characteristics setting screen

E3.R
no

Initial value: no
Setting range: no, nc

Set just like EV1.

To 4-17 screen

Heater break/loop alarm settings

Can be used if event option and CT input option is equipped.

4-17 Heater 1 break/loop alarm mode setting screen

Hb \bar{n} 1
out1

Initial value: out1
Setting range: out1, out2

Sets control output by which heater break/loop alarm is output by current detection by CT1.
Can be set only for control output Y or P.
4-17 – 4-22 will be displayed if output of control output 1 or 2 is Y or P, and CT input is selected at the same time.

4-18 Heater 1 break alarm action value setting screen

C1Hb
oFF

Initial value: oFF
Setting range: oFF, 0.1 – 50.0 (A)

Sets current value of heater break alarm detected by CT1.
When control output is ON, an alarm is output if the current value detected by CT1 is lower than the setting.

4-19 Heater 1 loop break alarm action value setting screen

C1HL
oFF

Initial value: oFF
Setting range: oFF, 0.1 – 50.0 (A)

Sets current value of heater loop alarm detected by CT1.
When control output is OFF, an alarm is output if the current value detected by CT1 is higher than the setting.

4-20 Heater 2 break/loop alarm mode setting screen

Hb \bar{n} 2
out1

Initial value: out1
Setting range: out1, out2

Sets control output by which heater break/loop alarm is output by current detection by CT2.
Can be set only for control output Y or P.

4-21 Heater 2 break alarm action value setting screen

C2Hb
oFF

Initial value: oFF
Setting range: oFF, 0.1 – 50.0 (A)

Sets current value of heater break alarm detected by CT2.
When control output is ON, an alarm is output if the current value detected by CT2 is lower than the setting.

4-22 Heater 2 loop break alarm action value setting screen

C2HL
oFF

Initial value: oFF
Setting range: oFF, 0.1 – 50.0 (A)

Sets current value of heater loop alarm detected by CT2.
When control output is OFF, an alarm is output if the current value detected by CT2 is higher than the setting.

Analog output settings

4-23 Analog output type setting screen

Ao. \bar{n}
PV

Initial value: PV (PV)
Setting range: PV, SV (SV), out1 (out1), out2 (out2)

Item to be output as analog signal is set from among 4 items: measured value (PV), target set values (SV), control output 1 (out1) and control output 2 (out2).
4-23 – 4-27 is not displayed if analog output is not selected.

4-24 Analog output scaling lower limit value setting screen

Ao.L
0.0

Initial value: 0.0
(For PV/SV, measuring range lower limit value; out1/out2 is 0.0)
Setting range: When PV or SV is selected, within measuring range
When out1 or out2 is selected: 0.0 – 100.0 (%)

Minimum values of analog output signal (0mV, 4mA, 0V) are set as scaling minimum value to be output.

To 4-25 screen

4-25 Analog output scaling higher limit value setting screen

Ao.H
800.0

Initial value: 800.0
(For PV/SV, measuring range higher limit value; out1/out2 is 100.0)
Setting range: When PV or SV is selected, within measuring range
When out1 or out2 is selected: 0.0 – 100.0 %

Maximum values of analog output signal (10mV, 20mA, 10V) are set as scaling maximum value to be output.

Inverse scaling is possible for Ao.L > Ao.H.
(Min. H-L=±1 count)

Characteristics by analog output scaling are as follows:

For Ao.L < Ao.H

For Ao.L > Ao.H

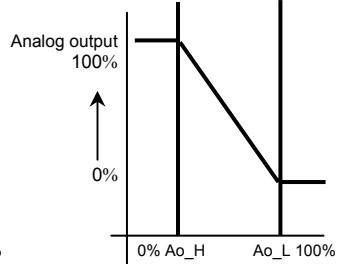
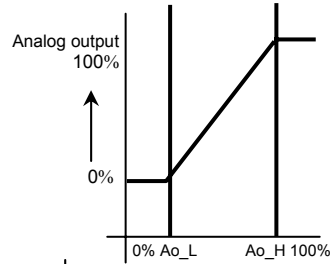

4-26 Analog output limiter lower limit value setting screen

AL.L
0.0

Initial value: 0.0 (%)
Setting range: 0.0 – 99.9 (%)

Sets lower limit value of analog output.

4-27 Analog output limiter higher limit value setting screen

AL.H
100.0

Initial value: 100.0 (%)
Setting range: (AL.L setting value) + 0.1 – 100.0 (%)

Sets higher limit value of analog output.

External control input DI settings

4-28 DI1 mode setting screen

di. \bar{n}
non

Initial value: non
Setting range: non, EXE1(run1), EXE2(run2), mAn, At, ESV2, ProG, HLd, Adv, Ptn2, Ptn3, L_rS

Select/allocate/set according to usage objective of external input (DI).

4-28 – 4-30 is not displayed if DI (external control input 3 points) is not selected.

DI mode allocation type code (used by 4-29, 4-30, 4-31)

| Code | External control input allocation type | Allocation possible DI No. | Detection |
|-------------|---|----------------------------|-----------|
| non | No selection | | |
| EXE1 (run1) | EXE/STBY (FIX fixed value control) RUN/RST (program control) | 1, 2, 3, 4 | Level |
| EXE2 (run2) | EXE/STBY (FIX fixed value control) RUN/RST (program control) | 1, 2, 3, 4 | Edge |
| mAn | MAN: Manual output | 1, 2, 3, 4 | Level |
| At | AT: Auto tuning execution | 1, 2, 3, 4 | Edge |
| ESV2 | ESV2: External selection 2bit | 1, 2 | Level |
| ProG | ProG: Program | 1, 2, 3, 4 | Level |
| HLd | HLd: Hold signal | 1, 2, 3, 4 | Level |
| Adv | Adv: Advance | 1, 2, 3, 4 | Edge |
| Ptn2 | Ptn2: Start pattern selection 2bit | 1, 2 | Level |
| Ptn3 | Ptn3: Start pattern selection 3bit | 1 | Level |
| L_rS | L_rS: Total unlatching | 1, 2, 3, 4 | Edge |

If ESV2/Ptn2 is allocated to DI1, DI2 cannot be selected.
If Ptn3 is allocated to DI1, DI2 and DI3 cannot be selected.
A single type of code cannot be allocated to more than one DI.

To 4-29 screen

4-29 DI2 mode setting screen

d2.n
non

Initial value: non
Setting range: non, EXE1(run1), EXE2(run2), mAn, At, ESV2, ProG, HLD, AdV, Ptn2, L_rS

Set just like 4-28 DI1 mode.

If ESV2/Ptn2 is assigned to DI2, DI3 cannot be selected.

4-30 DI3 mode setting screen

d3.n
non

Initial value: non
Setting range: non, EXE1(run1), EXE2(run2), mAn, At, ProG, HLD, AdV, L_rS

Set just like 4-28 DI1 mode.

4-31 DI4 mode setting screen

d4.n
non

Initial value: non
Setting range: non, EXE1(run1), EXE2(run2), mAn, At, ProG, HLD, AdV, L_rS

Set just like 4-28 DI1 mode.
Displayed when DI4 is selected.
Displayed if D (external control input 1 point, DI4) is selected for control output 2.

Communication settings

For communication function, see the Communications Interface Instruction Manual.

4-32 Communication mode setting screen

conn
Loc

Initial value: Loc (*Loc* [local])
Setting range: Loc, Com (*Conn* [Com])

Can be changed from Com to Loc with the front surface key.
Communication is made possible by mode displayed on bottom.

4-33 Communication address setting screen

Addr
1

Initial value: 1
Setting range: mASt, 1 – 255

Sets device No. when multiple controllers are connected for communication.
Setting to mASt sets the master mode.

4-34 Communication data format setting screen

data
7E1

Initial value: 7E1
Setting range: 7E1, 7E2, 7n1, 7n2, 8E1, 8E2, 8n1, 8n2

Sets data format for communications.

| ASCII RTU | Data length | Parity | Stop bit | Shimaden | MODBUS | |
|-----------|-------------|--------|----------|-----------------------|-----------------------|-----------------------|
| | | | | | ASCII | RTU |
| 7E1 | 7 bits | Even | 1 bit | <input type="radio"/> | <input type="radio"/> | - |
| 7E2 | 7 bits | Even | 2 bits | <input type="radio"/> | <input type="radio"/> | - |
| 7n1 | 7 bits | None | 1 bit | <input type="radio"/> | <input type="radio"/> | - |
| 7n2 | 7 bits | None | 2 bits | <input type="radio"/> | <input type="radio"/> | - |
| 8E1 | 8 bits | Even | 1 bit | <input type="radio"/> | - | <input type="radio"/> |
| 8E2 | 8 bits | Even | 2 bits | <input type="radio"/> | - | <input type="radio"/> |
| 8n1 | 8 bits | None | 1 bit | <input type="radio"/> | - | <input type="radio"/> |
| 8n2 | 8 bits | None | 2 bits | <input type="radio"/> | - | <input type="radio"/> |

4-35 Start character setting screen

SchA
StX

Initial values: StX (*StX*)
Setting range: StX, Att (*Att*)
Sets whether to use StX or Att (@) as the start characters of the communications format.
Valid only for Shimaden protocol.

4-36 BCC operation type setting screen

ChP
Add

Initial value: Add
Setting range: non, Add, Add2, Xor, Lrc, cr16

Process type of error detection BCC checking is set from the following table.

BCC operation type

| Operation | Description |
|-------------|--|
| <i>non</i> | None (Shimaden protocol) |
| <i>Add</i> | Add operation (Shimaden protocol) |
| <i>Add2</i> | 2's complement after add operation (Shimaden protocol) |
| <i>Xor</i> | Exclusive OR (Shimaden protocol) |
| <i>Lrc</i> | LRC (MODBUS ASCII) |
| <i>cr16</i> | CRC-16 (Modobus RTU) |

4-37 Communication speed setting screen

bP5
9600

Initial value: 9600 (bps)
Setting range: 1200, 2400, 4800, 9600, 1920, 3840

Sets communication speed.
1200 - 9600 : 1200(bps) – 9600(bps),
1920 : 19200(bps), 3840 : 38400(bps)

4-38 Communication delay time setting screen

dEL4
20

Initial value: 20
Setting range: 1 – 100

Sets delay time from when communication command is received till transmission.
Delay time = Setting value × 0.512 msec

4-39 Communication memory mode setting screen

EEP
EEP

Initial value: EEP (*EEP*)
Setting range: EEP, rAm (*rAn*), r_E (*r_E*)

Format for writing data in EEPROM and RAM during communication is set from the following table.

| Type | Writing process |
|------------|---|
| <i>EEP</i> | Writing entirely in EEPROM |
| <i>rAn</i> | Writing entirely in RAM |
| <i>r_E</i> | Writing SV, OUT1 and OUT2 in RAM and others in EEPROM |

4-40 Communication master mode setting screen

MS.n
SV

4-40 – 4-43 screens are displayed only when master mode is selected on the 4-33 communication address setting screen.
Initial value: SV
Setting range: SV, out1, o1SC, out2, o2SC
Select data for transmission to slave when in master mode.
Displayed only when in master mode.

| Type | Writing process |
|------|--|
| SV | Transmit execution SV value to slave. |
| OUT1 | Transmit output percentage value of output1. |
| O1SC | Transmit measuring range value for output percentage of output1. |
| OUT2 | Transmit output percentage value of output2. |
| O2SC | Transmit measuring range value for output percentage of output2. |

Note1: “(measuring range x output percentage + lower limit value of measuring range)” is the actual transmission data when O1SC/O2SC is selected.

4-41 Communication master mode start slave address setting screen

S.Ad
1

Initial value: 1
Setting range: bcAS, 1 – 255
bcAs: Broadcast

4-42 Communication master mode end slave address setting screen

E.Ad
1

Not displayed for bcAS (broadcast)
Initial value: 1
Setting range: Start address – start address + 30

4-43 Communication master mode write-in data address setting screen

wrLk
0300

Initial value: 0300 (H)
Setting range: 0000 (H) – FFFF (H)
Setting in hexadecimal notation.

4-44 Output 1 proportional cycling time setting screen

o.C1
30

Initial value: Contact output: 30 (seconds),
SSR drive voltage output: 3 (seconds)
Setting range: 1 – 120 (seconds)

Sets control output 1 proportional cycling time.
Not displayed when output type is voltage or current.
For information on proportional cycling time, see 8-3 (2).

4-45 Control output 1 characteristics setting screen

Act1
rA

Initial value: rA (*rA*)
Setting range: rA, dA (*dA*)

Sets characteristics of control output.
rA: Reverse characteristics (for heating)
dA: Direct characteristics (for cooling)
For information on control output characteristics, see 8-3 (3).

To 4-37 screen

To 4-46 screen

4-46 Control output 1 soft start time setting screen

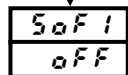

Initial value: oFF
Setting range: oFF, 1 – 120 (seconds)

Sets soft start time that gradually changes output.
Does not function if oFF is set.
For details, see 8-6.

4-47 Output 2 proportional cycling time setting screen

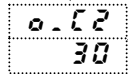

Initial value: Contact output: 30 (seconds),
SSR drive voltage output: 3 (seconds)
Setting range: 1 – 120 (seconds)

Sets control output 2 proportional cycling time.
Not displayed when output type is voltage or current.

4-48 Control output 2 characteristics setting screen

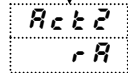

Initial value: rA (rA)
Setting range: rA, dA (dA)

Sets characteristics of control output.
rA (RA) : Reverse characteristics (for heating)
dA (DA) : Direct characteristics (for cooling)
Displayed if Y, I, P, V is selected for control output 2.

4-49 Control output 2 soft start time setting screen

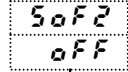

Initial value: oFF
Setting range: oFF, 1 – 120 (seconds)

Sets soft start time that gradually changes output.
Does not function if oFF is set.
For details, see 8-6.
Displayed if Y, I, P, V is selected for control output 2.

4-50 SV limiter lower limit setting screen

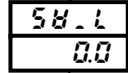

Initial value: Lower limit value of measuring range
Setting range: Lower limit value of measuring range to higher
limit value of measuring range - 1 count

If using setting range of target values below measuring range:
Set lower limit value.
(Able to prevent incorrect setting in danger range, etc.)

4-51 SV limiter higher limit setting screen

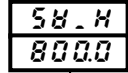

Initial value: Higher limit value of measuring range
Setting range: Higher limit value of measuring range to lower
limit value of SV limiter + 1 count

If using setting range of target values below measuring range:
Sets higher limit value.
(Able to prevent incorrect setting in danger range, etc.)

Note: For SV limiter setting, the lower limit value is given
preference when SV limiter lower limit value is less than
higher limit value. Consequently, higher limit cannot be
set less than lower limit value + 1 count.

If Sc_L/Sc_H are changed, the respective values are set for
SV_L/SV_H.

4-52 Number of patterns setting screen
(programming function only)

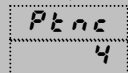

Initial value: 4
Setting range: 1, 2, 4

Sets number of patterns used by programming function.

4-53 Time unit setting screen (programming function only)

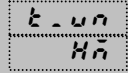

Initial value: Hm (Hn)
Setting range: Hm, mS (nS)

Sets time unit used by programming function.
Hm: Hour/minute, mS: Minute/second

To 4-54 screen

4-54 PV bias value setting screen

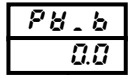

Initial value: 0 (unit)
Setting range: -1999 – 2000 (unit)

Used for compensating input error of sensors, etc.
When bias is applied, control is also executed according to the
compensated value.

4-55 PV gain compensation value setting screen

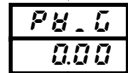

Initial value: 0.00 (%)
Setting range: -5.00 – 5.00 (%)

Used for compensating input gain error of sensors, etc.
When gain compensation is applied, control is also executed
according to the compensated value.

4-56 PV filter time setting screen

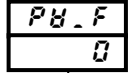

Initial value: 0 (seconds)
Setting range: 0 – 9999 (seconds)

Used to alleviate the effect if input varies radically or
noise is superimposed.
Filter does not function if set to 0 seconds.

4-57 Measuring range code setting screen

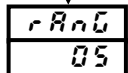

Initial value: Multi: 05, voltage: 86
Setting range: Selected from "Chapter 7: Measuring Range
Codes."

Combination of input type and measuring range is set by the code.
Setting cannot be changed during control action.

Note: Setting cannot be changed during control action on
4-57 – 4-61 screen. Change setting with standby
mode on 0-1 screen.
If the setting is modified, all data related to measuring
range will be initialized.

4-58 Input unit setting screen

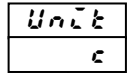

Initial value: c (C)
Setting range: c, F (F)

Temperature unit for sensor input is set to C (°C) or F (°F).
Not displayed if linear input (mV, V, mA) is selected.
K (K) is displayed if measuring range code is 15 – 18 (in kelvin).
Modification of unit is only possible when in standby mode.

4-59 Input scaling lower limit value setting screen

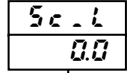

Initial value: 0.0 (unit)
Setting range: -1999 – 9989 (unit)

Sets scaling lower limit value for linear input (mV, V).
Cannot be set by monitoring screen for sensor input.

4-60 Input scaling higher limit value setting screen

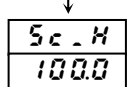

Initial value: 100.0
Setting range: (Sc_L setting value) + 10 – (Sc_L setting value)
+ 10,000

Sets scaling higher limit value for linear input (mV, V).
Cannot be set by monitoring screen for sensor input.

Note: If the difference between the higher limit value and
lower limit value is less than +10 count or higher than
+10,000 count, the higher limit value is automatically
changed to +10 count or +10,000 count. The higher
limit value cannot be set less than lower limit value +10
count or higher than +10,000 count.

4-61 Input decimal point position setting screen

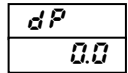

Initial value: 1 digit following decimal point (0.0)
Setting range: No decimal point (0) – 3 digits following
decimal point (0.000)

Sets decimal point position for input scaling.
Cannot be set by monitoring screen for sensor input.

To 4-0 screen

7. Measuring Range Codes

Select measuring range from the following table.
Changing the code initializes all data related to measuring range.

| Input type | | Code | Measuring range (°C) | Measuring range (°F) | |
|-----------------|--------------|------------|--|--|-------------------|
| Universal-input | Thermocouple | B | 01 *1 | 0 ~ 1800 °C | 0 ~ 3300 °F |
| | | R | 02 | 0 ~ 1700 °C | 0 ~ 3100 °F |
| | | S | 03 | 0 ~ 1700 °C | 0 ~ 3100 °F |
| | | K | 04 *2 | -199.9 ~ 400.0 °C | -300 ~ 750 °F |
| | | | 05 | 0.0 ~ 800.0 °C | 0 ~ 1500 °F |
| | | | 06 | 0 ~ 1200 °C | 0 ~ 2200 °F |
| | | E | 07 | 0 ~ 700 °C | 0 ~ 1300 °F |
| | | J | 08 | 0 ~ 600 °C | 0 ~ 1100 °F |
| | | T | 09 *2 | -199.9 ~ 200.0 °C | -300 ~ 400 °F |
| | | N | 10 | 0 ~ 1300 °C | 0 ~ 2300 °F |
| | | PL II *3 | 11 | 0 ~ 1300 °C | 0 ~ 2300 °F |
| | | WRe5-26 *4 | 12 | 0 ~ 2300 °C | 0 ~ 4200 °F |
| | | U *5 | 13 *2 | -199.9 ~ 200.0 °C | -300 ~ 400 °F |
| | | L *5 | 14 | 0 ~ 600 °C | 0 ~ 1100 °F |
| | Kelvin | K | 15 *6 | 10.0 ~ 350.0 K | 10.0 ~ 350.0 K |
| | | AuFe-Cr | 16 *7 | 0.0 ~ 350.0 K | 0.0 ~ 350.0 K |
| | | K | 17 *6 | 10 ~ 350 K | 10 ~ 350 K |
| | | AuFe-Cr | 18 *7 | 0 ~ 350 K | 0 ~ 350 K |
| | R.T.D | Pt100 | 30 | -100.0 ~ 350.0 °C | -150.0 ~ 650.0 °F |
| | | | 31 | -200 ~ 600 °C | -300 ~ 1100 °F |
| | | | 32 | -100.0 ~ 100.0 °C | -150.0 ~ 200.0 °F |
| | | | 33 | - 50.0 ~ 50.0 °C | - 50.0 ~ 120.0 °F |
| | | | 34 | 0.0 ~ 200.0 °C | 0.0 ~ 400.0 °F |
| | | JPt100 | 35 | -200 ~ 500 °C | -300 ~ 1000 °F |
| | | | 36 | -100.0 ~ 100.0 °C | -150.0 ~ 200.0 °F |
| | | | 37 | - 50.0 ~ 50.0 °C | - 50.0 ~ 120.0 °F |
| | | | 38 | 0.0 ~ 200.0 °C | 0.0 ~ 400.0 °F |
| | | | 39 | -100.0 ~ 350.0 °C | -150.0 ~ 650.0 °F |
| mV | -10 ~ 10mV | 71 | Initial value: 0.0 ~ 100.0 Input scaling setting range: -1999 ~ 9999 Span: 10 ~ 10,000 count Decimal point position: None, 1/2/3 digits following decimal point Lower limit value is less than higher limit value. | | |
| | 0 ~ 10mV | 72 | | | |
| | 0 ~ 20mV | 73 | | | |
| | 0 ~ 50mV | 74 | | | |
| | 10 ~ 50mV | 75 | | | |
| | 0 ~ 100mV | 76 | | | |
| Voltage | V | -1 ~ 1V | 81 | NOTE: For current input, install input terminals of the specified receiving impedance (250 Ω) and use code 84 (0 ~ 20 mA) or 85 (4 ~ 20 mA). | |
| | | 0 ~ 1V | 82 | | |
| | | 0 ~ 2V | 83 | | |
| | | 0 ~ 5V | 84 | | |
| | | 1 ~ 5V | 85 | | |
| | | 0 ~ 10V | 86 | | |

Thermocouple: B, R, S, K, E, J, T, N: JIS/IEC

R.T.D. Pt100: JIS/IEC JPt100

*1. Thermocouple B: Accuracy guarantee not applicable to 400°C (752°F) or below.

*2. Thermocouple K, T, U: Accuracy of those readings below -100°C is ±0.7% FS

*3. Thermocouple PLII: Platinel

*4. Thermocouple WRe5-26: A product of Hoskins

*5. Thermocouple U, L: DIN 43710

*6. Thermocouple K (Kelvin) accuracy

Temperature range

10.0 ~ 30.0 K ± (2.0%FS + [CJ error × 20] K + 1K)

30.0 ~ 70.0 K ± (1.0%FS + [CJ error × 7] K + 1K)

70.0 ~ 170.0 K ± (0.7%FS + [CJ error × 3] K + 1K)

170.0 ~ 270.0 K ± (0.5%FS + [CJ error × 1.5] K + 1K)

270.0 ~ 350.0 K ± (0.3%FS + [CJ error × 1] K + 1K)

*7. Thermocouple Metal-chromel (AuFe-Cr) (Kelvin) accuracy

Temperature range

0.0 ~ 30.0 K ± (0.7%FS + [CJ error × 3] K + 1K)

30.0 ~ 70.0 K ± (0.5%FS + [CJ error × 1.5] K + 1K)

70.0 ~ 170.0 K ± (0.3%FS + [CJ error × 1.2] K + 1K)

170.0 ~ 280.0 K ± (0.3%FS + [CJ error × 1] K + 1K)

280.0 ~ 350.0 K ± (0.5%FS + [CJ error × 1] K + 1K)

NOTE: Unless otherwise specified, the measuring range will be set as follows when shipped from the factory:

| Input | Standard/rating | Measuring range |
|-------------|-----------------|----------------------|
| Multi input | K thermocouple | 0.0 ~ 800.0°C |
| Voltage (V) | 0 ~ 10V DC | 0.0 ~ 100.0, no unit |

8. Explanation of functions

This section contains a description of operation not covered in “5.5 Screen group 0 setting.”

8-1. Events

(1) Alarm action

1) Deviation alarm

Sets alarm action points for deviation of measured values (PV) from target set values (SV).

For example, to trigger an alarm when measured value (PV) of 30°C or more when target set value is 20°C, the higher limit deviation alarm is set to 10°C.

Or to trigger an alarm when measured value (PV) of 30°C or less when target set value is 100°C, the lower limit deviation alarm is set to -70°C.

This is convenient if you want alarm action point to be in accordance with deviation from target set values. The setting range is -1999 – 2000 unit.

2) Absolute value alarm

Sets alarm action point by absolute value. Higher limit absolute value alarm and lower limit absolute value alarm can be set at any point within measuring range.

For example, to trigger an alarm when measured value reaches 50°C or higher, set the higher limit absolute value alarm to 50°C.

Or to trigger an alarm when measured value reaches 20°C or lower, set the lower limit absolute value alarm to 20°C.

3) Standby action

If event standby action is set to 1 (or 2), when power is applied, an event is not output even if the measured value is in the alarm action area (ON area) for target setting value change or standby cancel.

Once outside the alarm action area (OFF area) and standby action is canceled, an event is output when it once again enters the alarm action area.

4) Non-standby action

If event standby action is set to OFF and 3, an event is always output when the measured value is within the alarm action area.

5) Control mode

If standby action is set to 3, alarm is not triggered during scaleover or standby.

(2) Event standby action selection

The following are supplementary explanations of operation with “4-4, 4-9 and 4-14 event code standby action setting screen” of screen group 4.

① If using event output as an alarm, set from 1 or 2 of standby action code table.

② If using event output for control, set 3 (control mode). If 3 is set, however, event output remains OFF for abnormal input.

③ If set to 1, standby action functions when power is applied or standby is cancelled.

④ If set to 2, standby action functions when power is applied, when standby is canceled and when execution SV is changed.

• **NOTE1: Standby action is canceled immediately if changed to OFF or 3 during standby action.**

NOTE2: During scaleover, standby action is canceled.

(3) Event selection alarm action diagrams

The following are alarm action diagrams for selecting event (EV1/EV2/EV3).

△ : SV value

▲ : Alarm action point setting value

H d : Higher limit deviation alarm

L d : Lower limit deviation alarm

o d : Outside higher/lower limit deviation alarm

i d : Inside higher/lower limit deviation alarm

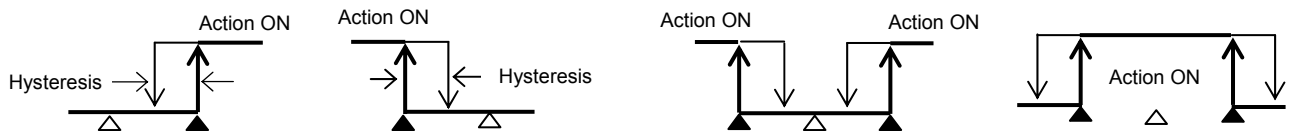

H R : Higher limit absolute value alarm

L R : Lower limit absolute value alarm

S o : Scaleover



(4) Event status output action

① **E 4 E** EXE signal

Fixed value control (FIX mode) output during control action.

② **r u n** RUN signal

Output during program execution during program control.

| | | | |
|---|-------------|------|---|
| ③ | <i>HC1</i> | HC1 | Output during alarm action of either heater 1 break/loop. |
| ④ | <i>HC2</i> | HC2 | Output during alarm action of either heater 2 break/loop. |
| ⑤ | <i>STPS</i> | STPS | Step signal Output for 1 second each time step in program control execution is completed. |
| ⑥ | <i>PTNS</i> | PTNS | Pattern signal Output for 1 second each time pattern in program control execution is completed. |
| ⑦ | <i>ENDS</i> | ENDS | Program end signal Output for 1 second when program control execution is completed. |
| ⑧ | <i>HOLD</i> | HOLD | Hold signal Output when holding (temporary halt of program) during program control. |
| ⑨ | <i>PROG</i> | PROG | Program signal Output when set to program mode. |
| ⑩ | <i>U_SL</i> | U_SL | Up slope signal Output during up slope step execution during program control. |
| ⑪ | <i>D_SL</i> | D_SL | Down slope signal Output during down slope step execution during program control. |

8-2. Heater break/loop alarm

Heater break/loop alarm can be used only in control output Y (contact) or P (SSR drive voltage output).

Heater break/loop alarm becomes effective if CT input or event output is equipped.

Heater break alarm outputs an alarm if the current value detected by CT when control output is ON is lower than the setting.

Heater loop alarm also outputs an alarm if the current value detected by CT when control output is OFF is higher than the setting.

In the SRS10 series, 2 points of CT input is equipped if the CT input option is selected.

Any break of 2 heating stages control heater or three-phase heater can be detected by using two CT.

For 2 heating stages

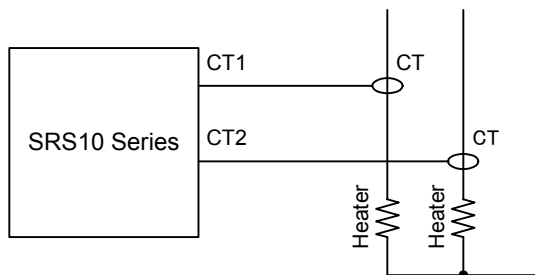

For three-phase

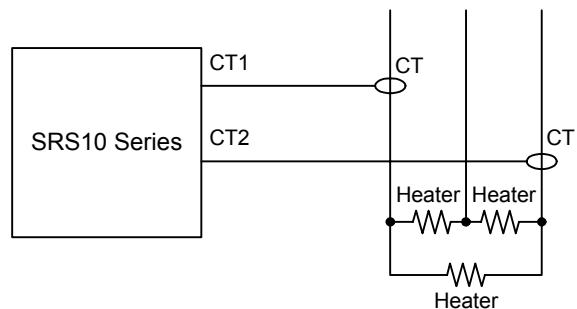

8-3. P.I.D.

(1) P (proportional action)

Sets percentage at which control output varies for measuring range. The size of control output varies according to ratio of PV value to SV value.

Slight proportional band variation results in strong proportional action. If it is too slight, control vibrates and the results of control are similar to ON-OFF action.

(2) I (Integral time)

Function that corrects offset (constant deviation) produced by proportional band. The longer the integral time, the weaker the corrective action and the shorter the time, the stronger the action is, but control may vibrate due to integral hunting.

(3) D (Derivative time)

Enhances stability by estimating change in control output and suppressing integral overshoot.

The longer the derivative time, the stronger derivative action is, but control results may be similar to vibration.

(4) MR (Manual reset)

With PID action "I" is automatically offset, but if "I" is OFF, it is not offset. If so, it can be offset by manually increasing/decreasing output. This is called "manual reset."

(5) SF (Target value function)

This function determines the strength of the overshoot preventing function when operating expert PID.

Expert PID suppresses overshoot by conducting operation for predicting and canceling the amount of overshoot by referring to the PID value and the variation of PV value when it reached the targeted setting value (SV) (or the proportional band).

Target value function is effective only when there is an integral operation (PI, PID operation).

SF= OFF: Expert PID does not function and normal PID operates.

SF= 1.00: Minimize overshoot for expert PID control.

SF→ Small: Overshoot preventing function works limitedly.

SF→ Large: Overshoot preventing function works fully.

8-4. Control output

(1) Lower limit and higher limit setting limiter

① Output limiter limits minimum and maximum values of control output and helps securing minimum temperature and suppress control overshoot.

② Lower limit value is given priority for output limiter setting. If minimum value is set above the higher limit value, the higher limit value forcibly becomes the lower limit value + 1%.
Higher limit value cannot be set less than lower limit value + 1%.

(2) Proportional cycling time

The correlation between proportional cycling time and control output are as shown in the following figure.

① Output 20%

Output ON

Output OFF

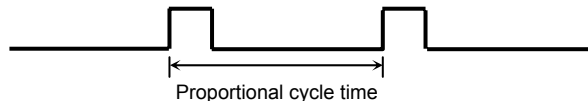

During the time equivalent to 20% when proportional cycling time is 100%, output is ON and is OFF for the time equivalent of the remaining 80%.

② Output 60%

Output ON

Output OFF

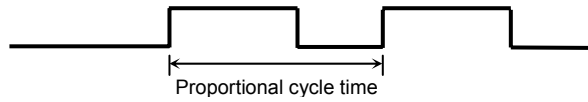

During the time equivalent to 60% when proportional cycling time is 100%, output is ON and is OFF for the time equivalent of the remaining 40%.

(3) Control output characteristics

Control output characteristics can be set independently for output 1 and output 2.
For heating, set to RA (reverse action) and for cooling set to DA (direct action).

Output characteristics

Control output with 2-output characteristics is as shown in the following figure. ① is heating/cooling control and ② is heat + heat control.

① 2-output heating/cooling action output characteristics

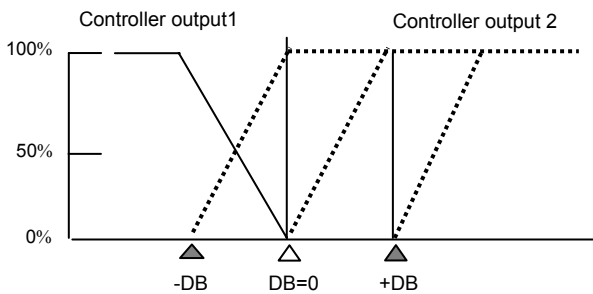

△: Target set values (SV) ▲: DB (dead band)
Dead band: Shifts proportional band of control output2 for setting value.

② 2-output heating/cooling action output characteristics

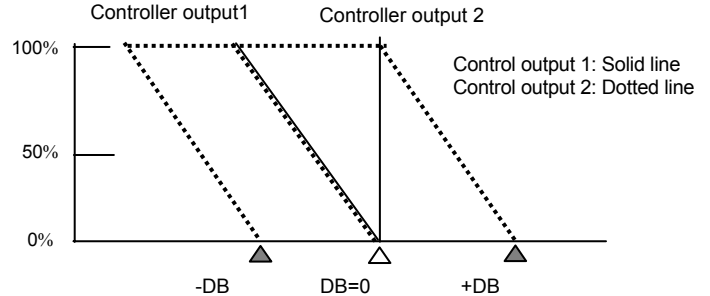

Control output 1: Solid line
Control output 2: Dotted line

8-5. External control input (DI)

Input must be retained for at least 250 ms to receive external control input of the SRS10 Series.
Assignment by DI input is conducted on the “4-28 – 4-31 DI mode setting screens.”
Function assigned to DI cannot be conducted by key operation.

(1) Controller action execution EXE1 (RUN1)

You can toggle between controller action execution/stop. Level action.

DI input OFF: Switches to standby (reset). SRS10 stops action.

DI input ON: Controller action is executed. PID operation control is executed (program control execution).

• **NOTE: If DI is ON when power is applied, controller action is executed immediately after power is applied.**

(2) Controller action execution EXE2 (RUN2)

Execution/stop is switched each time DI input is turned ON. (edge action).

NOTE: If DI is ON when power is applied, controller action is not executed immediately after power is applied.

(3) Manual output (MAN)

Switches to manual output. Level action.

DI input OFF: Ordinary feedback control action is executed.

DI input ON: Control output is executed manually; feedback control is not executed.

(4) Auto tuning execution (AT)

Auto tuning can be executed from outside. Edge action.

Once DI input is turned ON, auto tuning is executed.

If SV No. is switched by DI during AT execution, it is not applied until AT is finished.

AT in execution cannot be released by DI. Front key is used for releasing AT in execution (0-15 screen).

(5) SV external selection (ESV2)

Setting values of SV1 – SV3 can be switched to SV being executed. DI is level action using 2 points. Assignment to DI1 or DI2 can be set. Assigning/setting SV external selection to DI1 automatically allocates it to DI2 as well, so DI2 cannot be selected. Assigning/setting SV external selection to DI2 automatically allocates it to DI3 as well, so DI3 cannot be selected.

When assigned to DI1

| DI2 | DI1 | Selected SV No. |
|-----|-----|-----------------|
| 0 | 0 | 1 |
| 0 | 1 | 1 |
| 1 | 0 | 2 |
| 1 | 1 | 3 |

When assigned to DI2

| DI3 | DI2 | Selected SV No. |
|-----|-----|-----------------|
| 0 | 0 | 1 |
| 0 | 1 | 1 |
| 1 | 0 | 2 |
| 1 | 1 | 3 |

SV No. and PID No. being executed correspond to SV1/PID1, SV2/PID2, and SV3/PID3.

(6) Program (PROG)

You can switch FIX(fixed value control) and PROG(program) mode. Level action.

DI input OFF: FIX (fixed value control) mode
 DI input ON: Program (PROG) mode

(7) Hold signal (HLD)

Program execution can be halted from outside. Level action.
 DI input ON: Stops program step time.

(8) Advance (ADV)

Edge action.
 During program control execution, once DI input is turned ON, the current step is completed, and operation forcibly advances to the next step.

(9) Start pattern external selection 2 bits (PTN2)

You can select the program start pattern. DI is level action using 2 points. Assignment to DI1 or DI2 can be set. Assigning/setting start pattern selection to DI1 automatically assigns it to DI2 as well, so DI2 cannot be selected. Assigning/setting start pattern selection to DI2 automatically assigns it to DI3 as well, so DI3 cannot be selected.

When assigned to DI1

| DI2 | DI1 | Start pattern No. |
|-----|-----|-------------------|
| 0 | 0 | 1 |
| 0 | 1 | 1 |
| 1 | 0 | 2 |
| 1 | 1 | 3 |

When assigned to DI2

| DI3 | DI2 | Start pattern No. |
|-----|-----|-------------------|
| 0 | 0 | 1 |
| 0 | 1 | 1 |
| 1 | 0 | 2 |
| 1 | 1 | 3 |

Start pattern No.2 is executed if start pattern No.3 is selected and number of pattern is set to 2 on 4-52 screen.

(10) Start pattern external selection 3 bits (PTN3)

You can select the program start pattern. DI is level action using 3 points; only DI1 can be assigned/set. Assigning/setting start pattern selection 3 bits to DI1 automatically assigns it to DI2 and DI3 as well, so DI2 and DI3 cannot be selected.

| DI3 | DI2 | DI1 | Start pattern No. |
|-----|-----|-----|-------------------|
| 0 | 0 | 0 | 1 |
| 0 | 0 | 1 | 1 |
| 0 | 1 | 0 | 2 |
| 0 | 1 | 1 | 3 |
| 1 | 0 | 0 | 4 |
| 1 | * | * | 4 |

*SPT No. 4 regardless of ON/OFF.
 Start pattern No.2 is executed if start pattern No.3 or No.4 is selected and number of pattern is set to 2 on 4-52 screen.

(11) Total unlatching (L_RS)

Events can be unlatched from outside. Edge action.
 Once DI is turned ON, all event output is unlatched. Event output is however not unlatched if event output conditions have been satisfied.

8-6. Soft start

Soft start is a function that gradually increases control output by set time when power is applied, standby is canceled and operation is normally reset from scaleover. It is effective for preventing excessive current from being supplied to the heater, etc.

(1) Conditions that trigger soft start

- ① When power is applied in the automatic output mode, standby is canceled or normal reset from scaleover.
- ② When P (proportional band) is other than OFF on “2-1, 2-9 proportional band setting screen.”
- ③ When soft start time setting on “4-46, 4-49 soft start time setting screen” is not OFF.

(2) Conditions that cancel soft start

- ① When soft start time has elapsed normally.
- ② When output values of soft start are higher than PID operation output values.
- ③ When soft start time is changed to OFF.
- ④ When switched to manual mode.
- ⑤ When AT (auto tuning) is executed.
- ⑥ When P (proportional band) is changed to OFF.
- ⑦ When control output characteristics are changed.
- ⑧ When in standby mode.

9. Causes and remedy of trouble and errors

9-1. Causes and remedy of trouble

| Problem | Cause | Remedy |
|--|---|--|
| ① Error message is displayed. | See "Causes and remedy of errors." | See "Error Codes, Causes and Remedies." |
| ② Displayed measured value (PV) seems to be incorrect. | ① Set measuring range code is different from that of input sensor / input signal. ② Erroneous wiring to input terminals of sensor. | ① Check if set measuring range code is correct for input signal. ② Correct wiring to input terminals of sensor. |
| ③ Front panel display goes off and does not function. | ① Problem with power supply and/or wiring connection. ② Something is wrong with the instrument. | ① Inspect power supply / wiring connections and check wiring. ② Inspect, repair or replace the instrument. |
| ④ Keys do not work. | ① Key lock is in effect. ② Communication is set to Com during communication. ③ Something is wrong with the instrument. | ① Cancel key lock. ② Set communication to local (Loc). ③ Inspect, repair or replace the instrument. |
| ⑤ ON-OFF action of control output is too fast. | ① ON-OFF "hysteresis range is too narrow." | ① Widen ON-OFF "hysteresis range." |

9-2. Causes and remedy of errors

(1) Abnormal measured input

| Screen display | Problem | Cause | Remedy |
|-------------------|--|---|---|
| HHHH (HHHH) | Higher limit scaleover | ① Break in thermocouple input wiring. ② Break in R.T.D. input A wiring. ③ Input measured value exceeded higher limit of measuring range by 10%. | ① Check thermocouple input wiring for possible break. If there is nothing wrong with wiring, replace thermocouple. ② Check R.T.D. input A terminal wiring for possible break. If there is nothing wrong with wiring, replace R.T.D. ③ For voltage or current input, check the measurement signal transmission unit. Check if set measuring range code is correct for input signal. |
| LLLL (LLLL) | Lower limit scaleover | Input measured value fell below lower limit of measuring range by 10%. | Check for measurement input wiring for reverse polarity or possible break. |
| b --- (b ---) | Break in R.T.D. input wiring | ① Break in B wiring ② Multiple break in ABB wiring | Check R.T.D. input ABB terminal wiring for possible break. If there is nothing wrong with wiring, replace R.T.D. |
| [-] JHH (CJHH) | Higher limit scaleover of cold junction (CJ) of thermocouple input | Ambient temperature has exceeded 80°C. | ① Reduce ambient temperature to the level provided in the environment conditions for the product. ② If ambient temperature has not exceeded 80°C, examine the controller. |
| [-] JLL (CJLL) | Lower limit scaleover of cold junction (CJ) of thermocouple input | Ambient temperature has fallen below -20°C. | ① Raise ambient temperature to the level provided in the environment conditions for the product. ② If ambient temperature has not fallen below -20°C, examine the controller. |

(2) Heater break/loop alarm errors

| Screen display | Problem | Cause | Remedy |
|----------------|--|---|--|
| HbHH (HbHH) | Heater current sensor CT input value has exceeded 55.0A. | Excessive current | ① Reduce the current. ② Inspect the controller. |
| HbLL (HbLL) | Something is wrong with the instrument. | Something is wrong with the instrument. | Inspect, repair or replace the instrument. |

When the controller does not operate as intended and you suspect it may be broken, read the instruction manual and inspect once again. If there is something wrong with the controller or there is something you do not understand, contact your nearest Shimaden dealer.

10. Parameter setting record

For the sake of convenience, you should record your settings and selections.
Initial values for code 05 (K) are given here.

| Screen No. | Parameter (item)/screen | Initial value | Setting/selection | Record |
|------------|---|---------------|-------------------|--------|
| 0-0 | Basic screen (SV) | 0.0 (0.0) | 0.0 | |
| 0-1 | Standby action (FIX) | EXE (E4E) | E4E | |
| | Reset action (program) | RST (r5t) | r5t | |
| 0-2 | Output 1 monitoring | | | |
| 0-3 | Output 2 monitoring | | | |
| 0-4 | Execution step No. monitoring | | | |
| 0-5 | Remaining time of step monitoring | | | |
| 0-6 | Number of pattern executions monitoring | | | |
| 0-7 | PID execution monitoring | | | |
| 0-8 | Hold | HLd (HLd) | oFF | |
| 0-9 | Advance | AdV (AdV) | oFF | |
| 0-10 | Monitoring heater current 1 | HC_1 (HC_1) | | |
| 0-11 | Monitoring heater current 2 | HC_2 (HC_2) | | |
| 0-12 | Event 1 setting value setting | E1Hd (E1Hd) | 2000 | |
| 0-13 | Event 2 setting value setting | E2Ld (E2Ld) | 199.9 | |
| 0-14 | Event 3 setting value setting | E3Hd (E3Hd) | 2000 | |
| 0-15 | AT action | At (At) | oFF | |
| 1-0 | FIX initial screen | FiX (F24) | 5Et | |
| 1-1 | FIX ON/OFF | FiX (F24) | on | |
| 1-2 | SV No. | SVNo.(58no) | 1 | |
| 1-3 | SV1 setting | SV1 (581) | 0.0 | |
| 1-4 | SV2 setting | SV2 (582) | 0.0 | |
| 1-5 | SV3 setting | SV3 (583) | 0.0 | |
| PID No.1 | | | | |
| 2-0 | Initial screen | Pid1 (P1d1) | 5Et | |
| 2-1 | OUT1 PID P | 1_P1 (1.P1) | 3.0 | |
| 2-2 | OUT1 hysteresis | 1dF1 (1dF1) | 2.0 | |
| 2-3 | OUT1 PID I | 1_i1 (1.i1) | 120 | |
| 2-4 | OUT1 PID D | 1_d1 (1.d1) | 30 | |
| 2-5 | OUT1 manual reset | 1mr1 (1mr1) | 0.0 | |
| 2-6 | OUT1 PID target value function | 1SF1 (1SF1) | 0.40 | |
| 2-7 | OUT1 lower limit limiter | 1oL1 (1oL1) | 0.0 | |
| 2-8 | OUT1 higher limit limiter | 1oH1 (1oH1) | 100.0 | |
| 2-9 | OUT2 PID P | 2_P1 (2.P1) | 3.0 | |
| 2-10 | OUT2 hysteresis | 2dF1 (2dF1) | 2.0 | |
| 2-11 | OUT2 PID I | 2_i1 (2.i1) | 120 | |
| 2-12 | OUT2 PID D | 2_d1 (2.d1) | 30 | |
| 2-13 | OUT2 dead band | 2db1 (2db1) | 0.0 | |
| 2-14 | OUT2 PID target value function | 2SF1 (2SF1) | 0.40 | |
| 2-15 | OUT2 lower limit limiter | 2oL1 (2oL1) | 0.0 | |
| 2-16 | OUT2 higher limit limiter | 2oH1 (2oH1) | 100.0 | |
| PID No.2 | | | | |
| 2-0 | Initial screen | Pid2 (P2d2) | 5Et | |
| 2-1 | OUT1 PID P | 1_P2 (1.P2) | 3.0 | |
| 2-2 | OUT1 hysteresis | 1dF2 (1dF2) | 2.0 | |
| 2-3 | OUT1 PID I | 1_i2 (1.i2) | 120 | |
| 2-4 | OUT1 PID D | 1_d2 (1.d2) | 30 | |
| 2-5 | OUT1 manual reset | 1mr2 (1mr2) | 0.0 | |
| 2-6 | OUT1 PID target value function | 1SF2 (1SF2) | 0.40 | |
| 2-7 | OUT1 lower limit limiter | 1oL2 (1oL2) | 0.0 | |
| 2-8 | OUT1 higher limit limiter | 1oH2 (1oH2) | 100.0 | |
| 2-9 | OUT2 PID P | 2_P2 (2.P2) | 3.0 | |
| 2-10 | OUT2 hysteresis | 2dF2 (2dF2) | 2.0 | |
| 2-11 | OUT2 PID I | 2_i2 (2.i2) | 120 | |
| 2-12 | OUT2 PID D | 2_d2 (2.d2) | 30 | |
| 2-13 | OUT2 dead band | 2db2 (2db2) | 0.0 | |
| 2-14 | OUT2 PID target value function | 2SF2 (2SF2) | 0.40 | |
| 2-15 | OUT2 lower limit limiter | 2oL2 (2oL2) | 0.0 | |
| 2-16 | OUT2 higher limit limiter | 2oH2 (2oH2) | 100.0 | |
| PID No.3 | | | | |
| 2-0 | Initial screen | Pid3 (P3d3) | 5Et | |
| 2-1 | OUT1 PID P | 1_P3 (1.P3) | 3.0 | |
| 2-2 | OUT1 hysteresis | 1dF3 (1dF3) | 2.0 | |
| 2-3 | OUT1 PID I | 1_i3 (1.i3) | 120 | |
| 2-4 | OUT1 PID D | 1_d3 (1.d3) | 30 | |
| 2-5 | OUT1 manual reset | 1mr3 (1mr3) | 0.0 | |
| 2-6 | OUT1 PID target value function | 1SF3 (1SF3) | 0.40 | |
| 2-7 | OUT1 lower limit limiter | 1oL3 (1oL3) | 0.0 | |
| 2-8 | OUT1 higher limit limiter | 1oH3 (1oH3) | 100.0 | |

| Screen No. | Parameter (item)/screen | | Initial value | Setting/selection | Record |
|------------|--------------------------------------|----------------|--------------------|-------------------|--------|
| 2-9 | OUT2 PID P | 2_P3 (2.P3) | 3.0 | | |
| 2-10 | OUT2 hysteresis | 2dF3 (2dF3) | 2.0 | | |
| 2-11 | OUT2 PID I | 2_i3 (2.i3) | 12.0 | | |
| 2-12 | OUT2 PID D | 2_d3 (2.d3) | 3.0 | | |
| 2-13 | OUT2 dead band | 2db3 (2db3) | 0.0 | | |
| 2-14 | OUT2 PID target value function | 2SF3 (2SF3) | 0.40 | | |
| 2-15 | OUT2 lower limit limiter | 2oL3 (2oL3) | 0.0 | | |
| 2-16 | OUT2 higher limit limiter | 2oH3 (2oH3) | 100.0 | | |
| | | | | | |
| 4-0 | Initial screen | init (i n i t) | 5E2 | | |
| 4-1 | Key lock setting | LocK (L o c K) | o F F | | |
| 4-2 | Event 1 type | E1_m (E 1 . n) | H d | | |
| 4-3 | Event 1 hysteresis | E1_d (E 1 . d) | 2.0 | | |
| 4-4 | Event 1 standby action | E1_i (E 1 . i) | o F F | | |
| 4-5 | Event 1 latching | E1_L (E 1 . L) | o F F | | |
| 4-6 | Event 1 output characteristics | E1_A (E 1 . R) | n o | | |
| 4-7 | Event 2 type | E2-m (E 2 . n) | L d | | |
| 4-8 | Event 2 hysteresis | E2-d (E 2 . d) | 2.0 | | |
| 4-9 | Event 2 standby action | E2-i (E 2 . i) | o F F | | |
| 4-10 | Event 2 latching | E1_L (E 2 . L) | o F F | | |
| 4-11 | Event 2 output characteristics | E1_A (E 2 . R) | n o | | |
| 4-12 | Event 3 type | E3-m (E 3 . n) | n o n | | |
| 4-13 | Event 3 hysteresis | E3-d (E 3 . d) | 2.0 | | |
| 4-14 | Event 3 standby action | E3-i (E 3 . i) | o F F | | |
| 4-15 | Event 3 latching | E3_L (E 3 . L) | o F F | | |
| 4-16 | Event 3 output characteristics | E3_A (E 3 . R) | n o | | |
| 4-17 | HB1 break/loop alarm mode | Hbm1 (H b n 1) | o u t 1 | | |
| 4-18 | HB1 break alarm setting | C1Hb (C 1 H b) | o F F | | |
| 4-19 | HB1 loop alarm setting | C1HL (C 1 H L) | o F F | | |
| 4-20 | HB2 break/loop alarm mode | Hbm2 (H b n 2) | o u t 1 | | |
| 4-21 | HB2 break alarm setting | C2Hb (C 2 H b) | o F F | | |
| 4-22 | HB2 loop alarm setting | C2HL (C 2 H L) | o F F | | |
| 4-23 | Analog output type | Ao_m (A o . n) | P H | | |
| 4-24 | Analog output scaling lower limit | Ao_L (A o . L) | 0.0 | | |
| 4-25 | Analog output scaling higher limit | Ao_H (A o . H) | 800.0 | | |
| 4-26 | Analog output limiter lower limit | AL_L (A L . L) | 0.0 | | |
| 4-27 | Analog output limiter higher limit | AL_H (A L . H) | 100.0 | | |
| 4-28 | DI1 mode | D1_m (d 1 . n) | n o n | | |
| 4-29 | DI2 mode | D2_m (d 2 . n) | n o n | | |
| 4-30 | DI3 mode | D3_m (d 3 . n) | n o n | | |
| 4-31 | DI4 mode | D4_m (d 4 . n) | n o n | | |
| 4-32 | Communication mode setting | comm (c o m m) | L o c | | |
| 4-33 | Communication address | Addr (A d d r) | 1 | | |
| 4-34 | Communication data format | dAtA (d A t A) | 7E1 | | |
| 4-35 | Start character | SchA (S c h A) | 5E5 | | |
| 4-36 | BCC operation/protocol type | ChK (C h K) | A d d | | |
| 4-37 | Communication speed | bPS (b P S) | 9600 | | |
| 4-38 | Communication delay time | dely (d E L Y) | 20 | | |
| 4-39 | Communication memory mode | mem (m e m) | E E P | | |
| 4-40 | Communication master mode | mS_m (m S . n) | 5B | | |
| 4-41 | Start slave address | S_Ad (S . A d) | 1 | | |
| 4-42 | End slave address | E_Ad (E . A d) | 1 | | |
| 4-43 | Write-in data address | writ (w r i t) | 0300 | | |
| 4-44 | Output 1 proportional cycling time | o_C1 (o . C 1) | Y: 30, P: 3 | | |
| 4-45 | Output 1 output characteristics | Act1 (A c t 1) | r R | | |
| 4-46 | Output 1 soft start time | SoF1 (S o F 1) | o F F | | |
| 4-47 | Output 2 proportional cycling time | o_C2 (o . C 2) | Y: 30, P: 3 | | |
| 4-48 | Output 2 output characteristics | Act2 (A c t 2) | r R | | |
| 4-49 | Output 2 soft start time | SoF2 (S o F 2) | o F F | | |
| 4-50 | SV limiter lower limit value | SV_L (S V . L) | 0.0 | | |
| 4-51 | SV limiter higher limit value | SV_H (S V . H) | 800.0 | | |
| 4-52 | Number of patterns setting | Ptnc (P t n c) | 4 | | |
| 4-53 | Time unit | t_Un (t . U n) | H n | | |
| 4-54 | PV bias value | PV_b (P V . b) | 0.0 | | |
| 4-55 | PV gain compensation | PV_G (P V . G) | 0.00 | | |
| 4-56 | PV filter time | PV_F (P V . F) | 0 | | |
| 4-57 | Measuring range code | rAnG (r A n G) | Multi: 05 V: 86 | | |
| 4-58 | Input temperature unit | Unit (U n i t) | c | | |
| 4-59 | Input scaling lower limit | Sc_L (S c . L) | 0.0 | | |
| 4-60 | Input scaling higher limit | Sc_H (S c . H) | 800.0 | | |
| 4-61 | Input scaling decimal point position | dP (d P) | 0.0 | | |

11. Specifications

■ Display

- **Digital display** : Measured value (PV) / 7-segments red LED, 4 digits
Target set value (SV) / 7-segments green LED, 4 digits
- **Display accuracy** : $\pm(0.25\%FS + 1\text{digit})$
Does not include cold junction temperature compensation tolerance of thermocouple input. For details on accuracy, see "7. Measuring Range Codes."
- **Range for maintaining display accuracy** : 23°C \pm 5°C (18~28°C)
- **Display resolution** : Differs according to measuring range (0.001, 0.01, 0.1, 1)
- **Measured value display range** : -10%~110% of measuring range
Pt -200~600°C range is -240~680°C.
JPt -200~500°C range is -240~570°C.
- **Display update cycle** : 0.25 seconds
- **Action display/color** : 9 types, LED lamp display
Control output (OUT1, OUT2) / Green
Event (EV1, EV2, EV3) / Orange
Auto tuning (AT) / Green
Manual control output (MAN) / Green
Action display (RUN) / Green
Communication (COM) / Green

■ Setting

- **Setting method** : By operating 5 front panel keys (◀ ▶ ▲ ▼ ▢)
- **Target value setting range** : Same as measuring range (except within setting limiter)
- **Setting limiter** : high/low individually set, optional within measuring range (lower limit value less than higher limit value)
- **Key lock** : No lock, 3-stage setting

■ Input

- **Type of input** : Universal (TC, Pt, mV) or voltage (V)
- **Thermocouple** : B, R, S, K, E, J, T, N, PLII, WRe5-26, {U, L(DIN43710)}, Metal-chromel (AuFe-Cr)
Input resistance : Min. 500k Ω
External resistance tolerance : Max. 100 Ω
Burnout function : Standard feature (up scale)
Cold junction compensation accuracy : $\pm 2^\circ\text{C}$ (ambient temperature within 5~45°C)
 $\pm 3^\circ\text{C}$ when closely-mounted is series
- **R.T.D.** : Pt100/JPt100 3-wire type
Amperage : 0.25 mA
Lead wire tolerable resistance : Max. 5 Ω per wire (resistance for all wires must be equal)
- **Voltage mV** : -10~10, 0~10, 0~20, 0~50, 10~50, 0~100mV DC
V : -1~1, 0~1, 0~2, 0~5, 1~5, 0~10 V DC
Input resistance : Min. 500k Ω
Current input (0~20, 4~20 mA DC) handled by external receiving impedance (250 Ω , sold separately)
- **Input scaling function** : Scaling during voltage (mV, V) possible
Scaling range : -1999~9999 counts
Span : 10~10,000 counts
Position of decimal point : None, 1, 2, 3 digits below decimal point
- **Sampling cycle** : 0.25 seconds
- **PV bias** : -1999~2000 units
- **PV filter** : 0~9999 seconds
- **PV gain** : -5.00~+5.00%, gain compensation possible
- **Isolation** : Not isolated during input and system DI/CT input. Isolated for others.

■ Control

- **Control mode**
With 1 output : Expert PID control with auto tuning function
With 2 output : Expert PID control with auto tuning function
PID (output1) + PID (output2)
- **Type of control type/rating** : Contact / 1a 240V AC 2A (resistive load) 1.2A (inductive load)
SSR drive voltage / 12V \pm 1.5V DC (max. load current 30 mA)
Current / 4~20 mA DC (max. load resistance 600 Ω)
Voltage / 0~10V DC (max. load current 2 mA)
- **Control output resolution** : Control output 1: Approx. 0.0125% (1/8000)
Control output 2: Approx. 0.5% (1/200)
- **Control output accuracy** : Control output 1: $\pm 1.0\%FS$
Control output 2: $\pm 2.0\%FS$
- **Control output 1**
Proportional band (P) : OFF, 0.1~999.9% (ON-OFF action by OFF)
Integral time (I) : OFF, 1~6000 seconds (P or PD action by OFF)
Derivative time (D) : OFF, 1~3600 seconds (P or PI action by OFF)
Target value function : OFF, 0.01~1.00
ON-OFF hysteresis : 1~999 unit (enabled when P = OFF)
Manual reset : -50.0~50.0% (enabled when I = OFF)
Higher/lower limit output limiter : Lower limit 0.0~99.9%, higher limit 0.1~100.0% (Lower limit value less than higher limit value)
Proportional cycle : 1~120 seconds (contact or SSR drive voltage output)

● Control output 2 (option)

- Proportional band (P)** : OFF, 0.1~999.9% (ON-OFF action by OFF)
- Integral time (I)** : OFF, 1~6000 seconds (P or PD action by OFF)
- Derivative time (D)** : OFF, 1~3600 seconds (P or PI action by OFF)
- Target value function** : OFF, 0.01~1.00
- ON-OFF hysteresis** : 1~999 unit (enabled when P = OFF)
- Dead band** : -1999~5000 (unit)
- Higher/lower limit output limiter** : Lower limit 0.0~99.9%, higher limit 0.1~100.0% (Lower limit value less than higher limit value)
- Proportional cycle** : 1~120 seconds (contact or SSR drive voltage output)

● Manual control

- Output setting range** : 0.0~100.0%
- Setting resolution** : 0.1%
- Manual-auto switching** : Balanceless bumpless (within proportional band range)
- **Soft start** : Set separately for output 1 and output 2; OFF, 1~100 seconds
- **AT point** : SV value in execution
- **Control output characteristics** : RA (reverse characteristics) / DA (direct characteristics), front panel keys, switch by communication
Set separately for output 1 and output 2
RA (reverse characteristics): Heating
DA (direct characteristics): Cooling
- **Isolation** : Contact output: Isolation for all
Not isolated for SSR drive voltage, current, voltage and during analog output. Isolated for other (however 1-way output not isolated during 2-way output for SSR drive voltage, voltage, current and voltage output)

■ Event output (option, max. 3 point)

- **Number of output points** : 3 points: EV1, EV2 and EV3
No exclusive selection for EV1 and EV2
Exclusive selection of EV3 for control output 2 and DI4
- **Types of event** : Select from among the following 19 types for EV1, EV2 and EV3:

| | | | |
|-------------|--------------------------------------|-------------|----------------------------|
| <i>no n</i> | No selection | <i>LR</i> | Lower limit absolute value |
| <i>Hd</i> | Higher limit deviation | <i>So</i> | Scaleover |
| <i>Ld</i> | Lower limit deviation | <i>EXE</i> | EXE signal |
| <i>od</i> | Outside higher/lower limit deviation | <i>HC 1</i> | Heater 1 break/loop |
| <i>id</i> | Inside higher/lower limit deviation | <i>HC 2</i> | Heater 2 break/loop |
| <i>HR</i> | Higher limit absolute value | | |

The following 8 types are valid for program mode only:

| | | | |
|---------------|--------------------|-------------|-------------------|
| <i>run</i> | RUN signal | <i>Hold</i> | Hold signal |
| <i>StPS</i> | Step signal | <i>Prog</i> | Program signal |
| <i>Pt n S</i> | Pattern signal | <i>u-SL</i> | Up slope signal |
| <i>End S</i> | Program end signal | <i>d-SL</i> | Down slope signal |

- **Event setting range** : Absolute value (both higher/lower limit), within measuring range
Deviation (both higher/lower limit), -1999~2000 units
Higher/lower limit deviation (inside/outside), 0~2000 units
- **Event action** : ON-OFF action
- **Hysteresis** : 1~999 units
- **Standby action** : Selected from among the following 4 types
No standby
Standby 1 Standby when power is applied and when STBY (RST) switches to EXE (RUN).
Standby 2 Standby when power is applied and when STBY (RST) switches to EXE (RUN) and standby when executed SV value changes.
No standby control action No alarm output for abnormal input
- **Output type/rating** : Contact (EV1/EV2, 1a \times 2 points common, EV3 1a independent) /240V AC, 2A (resistive load)

- **Output updating cycle** : 0.25 seconds
- **Latching function** : ON/OFF selection
- **Output characteristics** : NO/NC selection
- **Isolation** : Isolation for all

■ Programming function (option)

- **Number of patterns** : Max. 4 (can be set to 1, 2 or 4)
- **Number of steps** : Max. 8 (4 patterns), 16 (2 patterns)
32 (1 pattern), total number of steps = 32
- **Number of PID types** : Max. 3
- **Time setting** : 0 minutes, 0 seconds~99 minutes, 59 seconds per step
Or 0 hours, 0 minutes~99 hours, 59 minutes per step
- **Setting resolution** : 1 minute or 1 second
- **Time accuracy** : \pm (setting time \times 0.005 + 0.25 seconds)
- **Setting pattern for each step** : SV, step time, PID No.
- **Number of pattern executions** : Max. 9999
- **PV start** : ON/OFF
- **Hold** : Front panel key input, external control input or communication
- **Advance** : Front panel key input, external control input or communication
- **Power failure compensation** : None (Setting contents are maintained and elapsed time, execution step and number of executions are reset.)

- **External control input/DI (option)**
- **Number of inputs SRS11** : Max. 4 points
Exclusive selection with 3 points CT input (DI1, DI2, DI3)
Exclusive selection with 1 point (DI4), control output 2 and event output (EV3)
- SRS13/SRS14** : Max. 4 points
Exclusive selection with 3 points (DI1, DI2, DI3)
Exclusive selection with 1 point (DI4), control output 2 and event output (EV3)
- **Type of DI allocation** : Selected for each DI from among the following 12 types:
No allocation, EXE1 (RUN1), EXE2 (RUN2), MAN, AT, ESV2, PROG, HLD, ADV, PTN2, PTN3, L_RS
- **Action input** : Non-voltage contact or open collector
(Level action) approx. 5V DC, 1mA or less
- **Minimum level holding time** : 0.25 seconds
- **Isolation** : Isolated except during DI, input, system, CT input
- **CT input (option) (for heater break / loop alarm)**
2-point detection; exclusive selection with DI1, DI2 and DI3 for SRS11
No exclusive selection for SRS13 and SRS14
- **Types of current detection Target** : Allocation for OUT1 and OUT2 is possible.
Only when output type is contact or SSR drive voltage, can be selected.
- **Current detection method** : By CT sensor (sold separately)
- **Current capacity** : 30A/50A (CT sensor sold separately)
- **Current setting range** : OFF, 0.1~50.0 A (alarm action off when set to OFF)
- **Setting resolution** : 0.1A
- **Current display range** : 0.0~55.0 A
- **Display accuracy** : ±2.0 A (for sine wave 50 Hz)
- **Alarm action** : Heater break detection when control output ON: Alarm output ON
Heater loop alarm detection when control output OFF: Alarm output ON
- **Alarm output** : Output for event by event assignment
- **Minimum time for action confirmation** : 0.25 seconds for both ON and OFF (each 0.5 second)
- **Alarm maintain mode** : Latching function ON/OFF
- **Standby action** : Selection of no (oFF) or yes (1)
Standby when power applied only
- **Sampling cycle** : 125 msec
- **Isolation** : Isolated except during CT input, input, system and DI
- **Communication function (option)**
Exclusive selection with analog output for SRS11
- **Type of communication** : EIA standard RS-485
- **Communication system** : 2-line half duplex start-stop synchronization system
- **Communication speed** : 1200, 2400, 4800, 9600, 19200, 38400 bps
- **Data format** : Select from among 7E1, 7E2, 7N1, 7N2, 8E1, 8E2, 8N1, 8N2
- **Communication delay time** : 1~100 (x 0.512 msec)
- **Max. number of connections** : 32 including host
- **Communication address** : 1~255
- **Communication code** : ASCII, MODBUS RTU binary code only
- **Communication Protocol** : Shimaden standard protocol / MODBUS ASCII, RTU
- **Other** : Start character and BCC operating method can be selected.
- **Communication memory mode** : Select from among EEPROM, RAM and E-R
- **Communication master mode** : Can be used as master device when using multiple unit communication
- Start slave address setting** : Broadcast, 1~255
- End slave address setting** : Start address ~ start address +30
- Write-in data address setting** : 0000H~FFFFH
- **Isolation** : Isolation for all
- **Communication distance** : Max. 500 m (differs according to conditions)

- **Analog output (option)**
Exclusive selection with communication for SRS11
- **Number of output points** : 1 point
- **Types of output** : Select from among measured value, target set values (execution SV), control output 1 and control output 2.
- **Output signal/rating** : 4~20 mA DC (max. load resistance 300Ω)
0~10V DC (max. load current 2 mA)
0~10mV DC (output resistance 10Ω)
- **Output scaling** : Within measuring range or output range
Inversed scaling possible
- **Output limiter** : Lower limit 0.0~99.9%, higher limit 0.1~100.0%
(Lower limit value less than higher limit value)
- **Output accuracy** : ±0.3%FS (for display value)
- **Output resolution** : Approx. 0.01% (1/10000)
- **Output updating cycle** : 0.25 seconds
- **Isolation** : No isolation with control output P, I and V
- **General specifications**
- **Data storage** : Non-volatile memory (EEPROM)
- **Ambient conditions for operations**
 - Temperature** : -10~50°C
 - Humidity** : Max. 90%RH (no dew condensation)
 - Elevation** : Max. 2000 m above sea level
 - Category** : II
 - Pollution class** : 2
- **Storage temperature** : -20~65°C
- **Supply voltage** : 100~240V AC±10%, 50/60Hz
or 24V AC/DC±10%
- **Power consumption** : SRS11 Max. 11VA for 100~240V AC
4W for 24V DC, 6VA for 24V AC
SRS13/14 Max. 14VA for 100~240V AC
6W for 24V DC, 8VA for 24V AC
- **Input/noise removal ratio** : Normal mode minimum 50dB (50/60 Hz)
- **Insulation resistance** : Between input/output terminals and power terminal
Min. 500V DC, 20 MΩ
- **Dielectric strength** : Between input/output terminals and power terminal,
2300V AC, 1 minute
Between input and output, 500V AC, 1 minute
- **Applicable standards**
 - Safety** : IEC61010-1 and EN61010-1
 - EMC** : EN61326
- **Material of case** : PPO resin molding (equivalent of UL94V-1)
- **External dimensions**
 - SRS11 : H48×W48×D66 mm (in panel 62mm)
 - SRS13 : H96×W96×D69 mm (in panel 65mm)
 - SRS14 : H96×W48×D66 mm (in panel 62mm)
- **Mounting** : Push-in panel (one-touch mount)
- **Panel thickness** : 1.0~3.5mm
- **Panel cutout**
 - SRS11 : H45×W45 mm
 - SRS13 : H92×W92 mm
 - SRS14 : H92×W45 mm
- **Weight**
 - SRS11 : Approx. 120 g
 - SRS13 : Approx. 220 g
 - SRS14 : Approx. 160 g

The contents of this manual are subject to change without notice.

Temperature and Humidity Control Specialists **SHIMADEN CO., LTD.**

Head Office: 2-30-10 Kitamachi, Nerima-ku, Tokyo 179-0081 Japan
Phone: +81-3-3931-7891 Fax: +81-3-3931-3089
E-MAIL: exp-dept@shimaden.co.jp URL: http://www.shimaden.co.jp

PRINTED IN JAPAN

T0809***