

# KitchenAid® Installation Instructions

Part No. 2000495 Rev. A

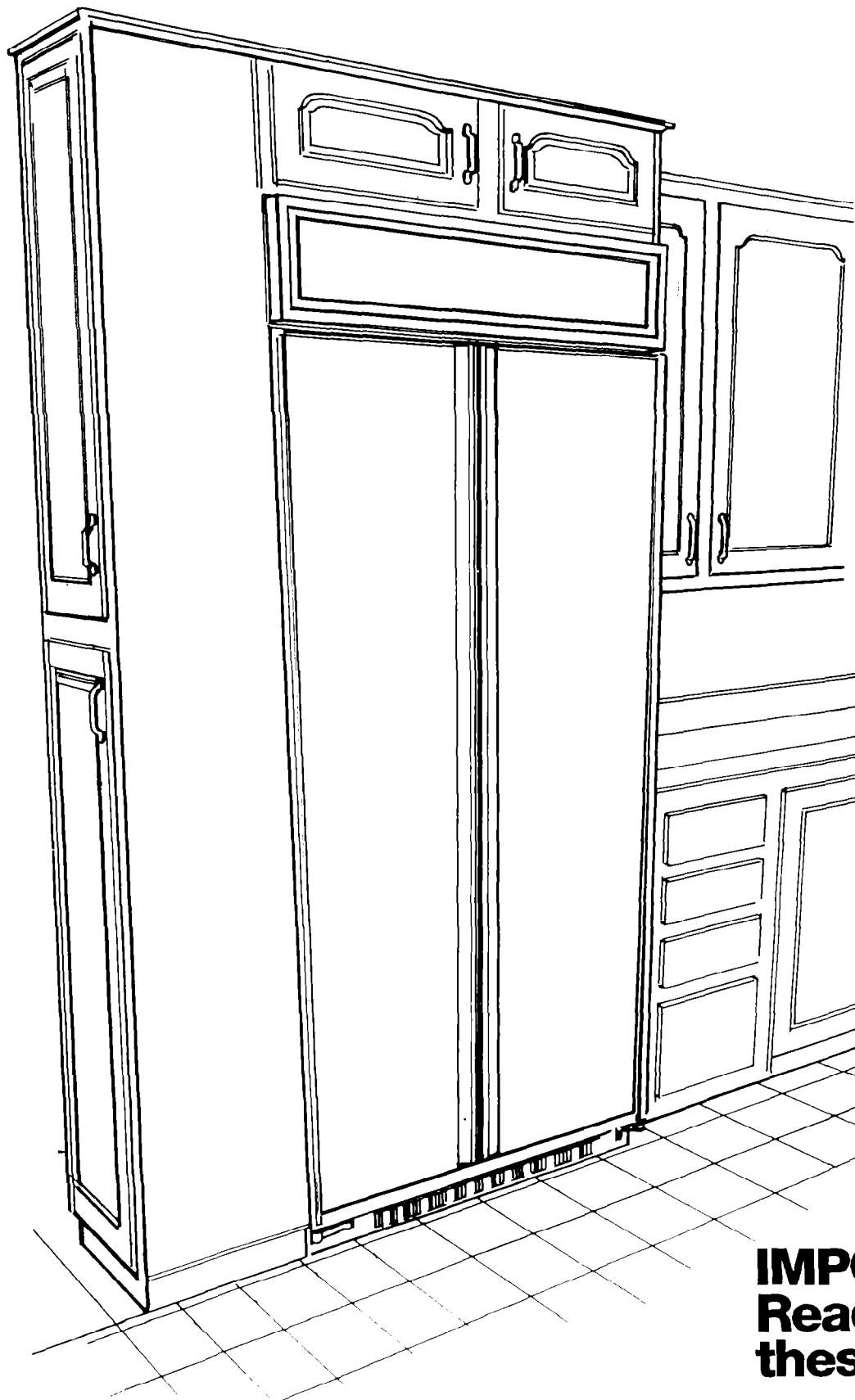

## 42" Built-In Refrigerator

### IMPORTANT:

**Installer:** Leave Installation Instructions with the Homeowner.  
**Homeowner:** Keep Installation Instructions for future reference.  
**Save** Installation Instructions for local electrical inspector's use.

7-92

**IMPORTANT:  
Read and save  
these instructions.**

## Before you start...

Proper installation is your responsibility. Make sure you have everything necessary for correct installation. It is the responsibility of the installer to comply with the installation specifications provided.

The built-in refrigerator weighs over 500 pounds. The floor must be sturdy enough to support this weight plus the additional weight of door panels, food and ice.

Grounded electrical outlet is required. See Electrical requirements.

Location of the built-in refrigerator must permit the doors to open to at least 90°.

Because of the weight and size of the built-in refrigerator, two or more people are needed to move and safely install it.

Dimensions that are shown must be used. Given dimensions provide required 0" clearance.

One inch of space is required between side of refrigerator and a corner wall to allow the door to open to at least a 90° angle.

### **⚠ WARNING**

#### Electrical Shock Hazard

It is the customer's responsibility:

- To contact a qualified electrical installer.
- To assure that the electrical installation is adequate and in conformance with National Electrical Code, ANSI/NFPA 70- latest edition, and all local codes and ordinances.

Failure to do so could result in electrical shock or other personal injury.

### **⚠ WARNING**

#### Electrical Shock Hazard

Special care must be taken when drilling holes into the wall of the house. Electrical wires may be concealed behind wall covering.

### **⚠ WARNING**

#### Personal Injury Hazard

- Because of the weight and size of the built-in refrigerator, two or more people are needed to move and safely install it.
- Most of the refrigerator's weight is at the top. Extra care is needed when moving the refrigerator to prevent tipping.

Failure to do so could result in personal injury.

### **⚠ CAUTION**

#### Floor Damage

Keep cardboard shipping piece or plywood under refrigerator until it is installed in operating position.

Failure to do so may cause damage to floor covering.

**Important: Observe all governing codes and ordinances.**

Failure to meet codes and ordinances could lead to fire or electrical shock hazard.

## Tools and materials needed for installation:

- |  |                           |
|--|---------------------------|
| Phillips screwdriver                                       | stepladder                |
| 5/16" and 3/4" socket and ratchet                          | wrench set                |
| 1/4" copper tubing   | knife                     |
| tubing cutter  | 3/16" and 1/4" drill bits |
| appliance dolly  | drill                     |
| 1/8" Allen wrench  | screwdriver               |
| adjustable wrench  | level                     |
| cardboard or plywood                                       | bucket                    |
| 6, #8, or larger wood screws                               | shutoff valve             |
| 2, wood boards - 32" long (See page 7 for specifications.) | stud locator              |
| 1 - 3/8" open wrench - front leveler                       | 1/4" nut driver           |

## Parts supplied for installation:

top grille assembly  
base grille  
tube assembly  
misc. parts bag  
ice-maker bin assembly

Remove parts from packages. Check that all parts were included.

## Parts that must be ordered separately or custom-made:

### Door panel kits

Three colors of acrylic door panel kits: White, Black and Almond, and a stainless steel door panel kit are available from your KitchenAid dealer. Each kit includes door panels and top grille panels. Follow kit instructions to install panels.

Kit Numbers for Panels

White	4318636
Black	4318633
Almond	4318639
Stainless Steel	4318642

### Custom door panels and top grille panels

See page 5 for custom panel dimensions and pages 10 and 11, Steps 9-12 for installation.

### Side panels

Check with your builder or installer to see if you need side panels that match your kitchen cabinets. Side panels must be custom-made. Side panel dimensions are given on page 6.

# Dimensions for built-in area

## ⚠ WARNING

### Personal Injury/Property Damage Hazard

- Unit is top-heavy and may tip forward when the doors are opened.
- A solid soffit or 2" wood block is required above the refrigerator to prevent tipping during use.
- If solid soffit is more than 1 inch above refrigerator, a wood block must be installed on the wall not more than 1/4 inch above the refrigerator cover.

Failure to follow these instructions could result in personal injury or property damage.

Width and depth of the built-in area are determined by the type of installation. The built-in refrigerator can be installed with the doors flush with the wall, with the doors protruding from the wall, or with side panels enclosing refrigerator. Select one method of installation and use the dimensions given for that method as shown.

Height of built-in area can range from a minimum of 82-1/2" to 84-3/4".

Optional top grilles may be required for enclosures less than 83-5/8". Height dimensions with optional top grilles are given on page 4.

+/- 1/8" tolerance

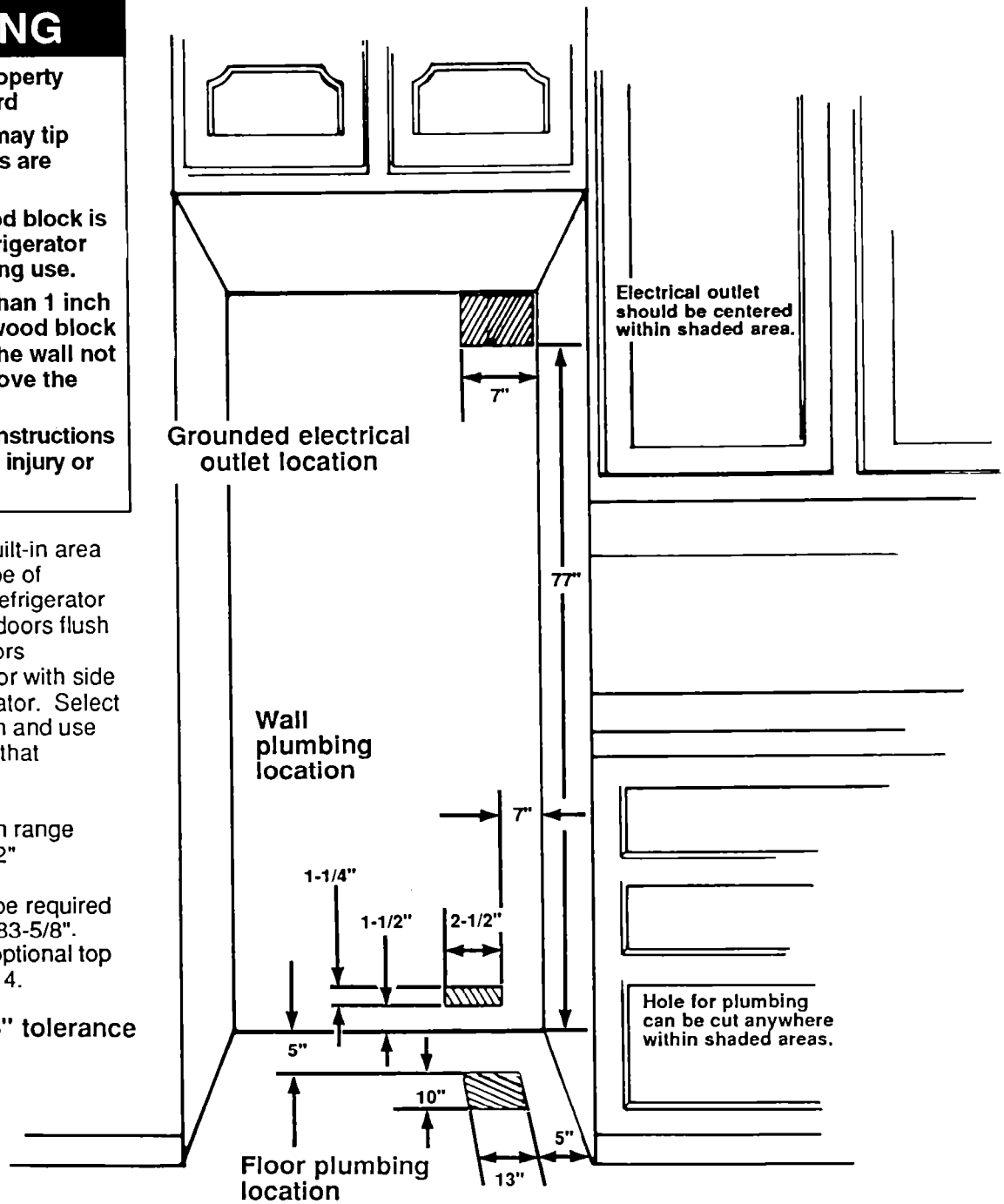

# Dimensions for tipping product

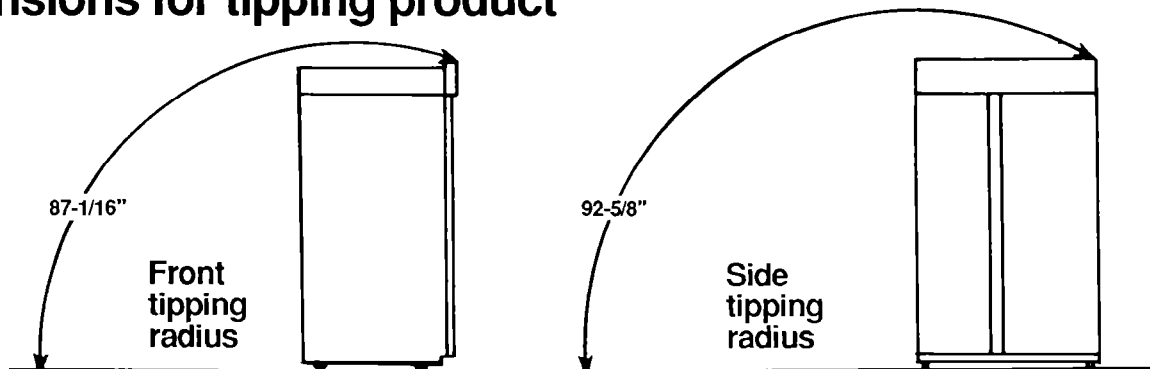

# Product dimensions

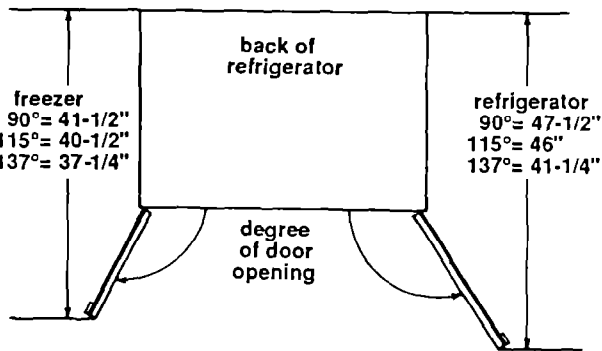
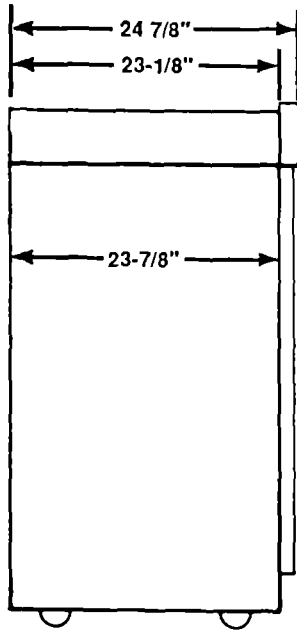

## \*Top grille

The 8-1/2" top grille is provided. Smaller top grilles must be ordered from your KitchenAid dealer. Check the chart below for the part numbers you need to order for the size of top grille you need.

## Optional Top Grilles

Size	Part Number	Description	Quantity
7-1/2"	4318418	Right side trim	1
		Left side trim	1
		Decorative panel	2
		side frame	2
		Air vane	1
8"	4318419	Right side trim	1
		Left side trim	1
		Decorative panel	2
		side frame	2
		Air vane	1

## Levelers extended 1/8" below rollers

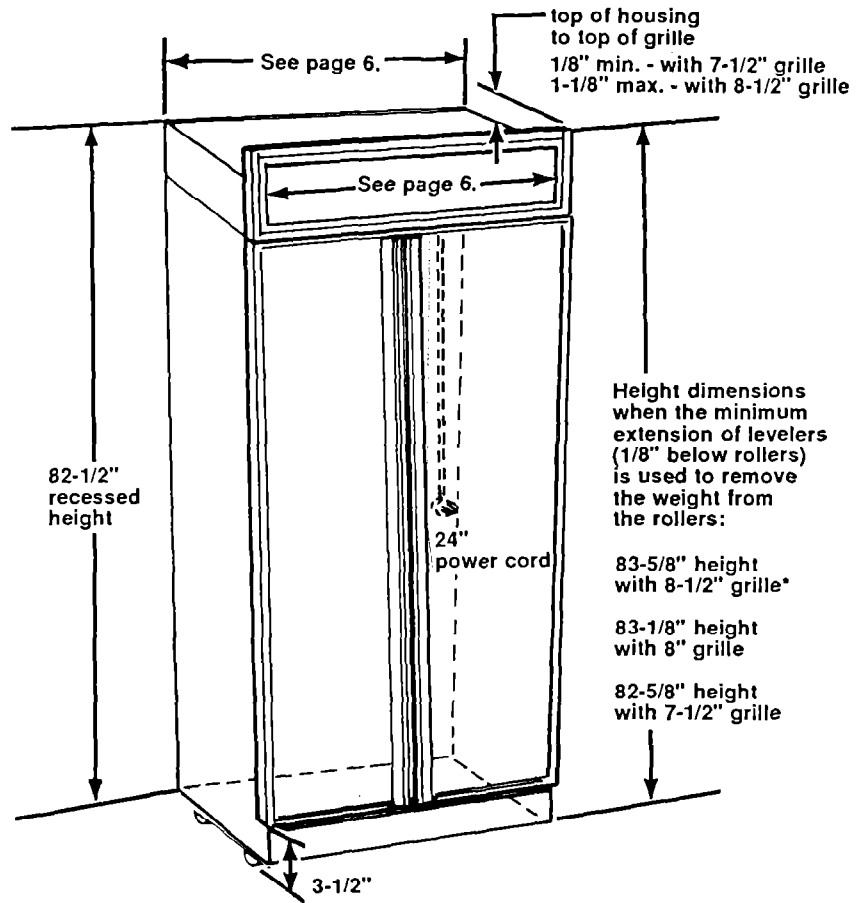

## Levelers fully extended 1-1/4" below rollers

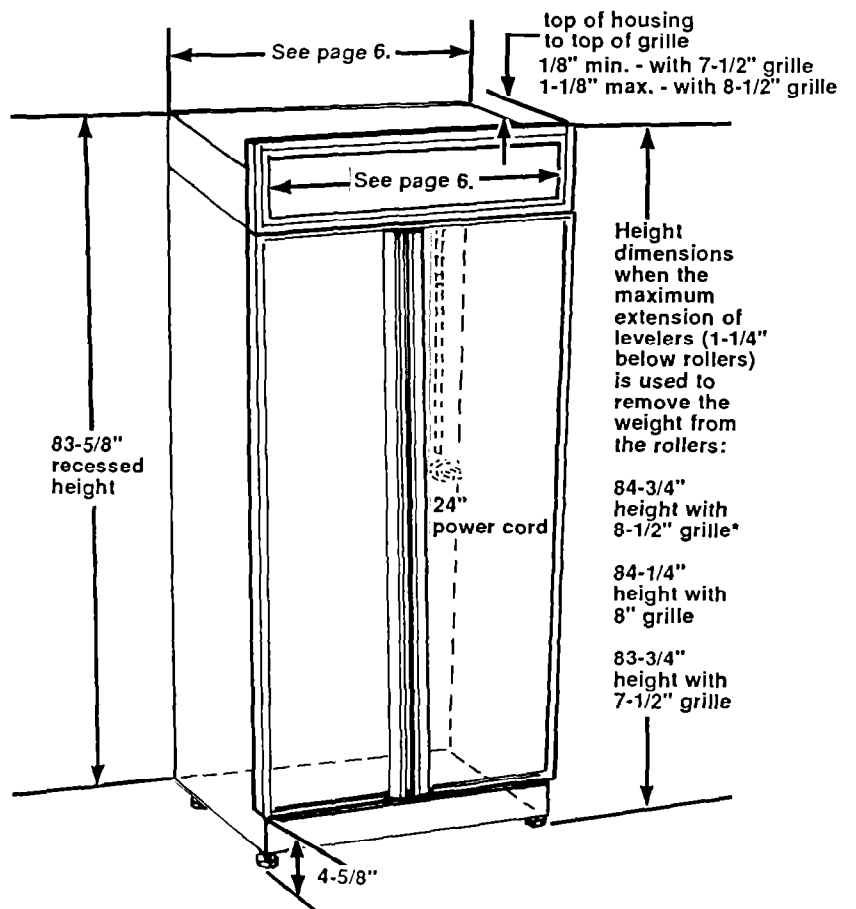

**Custom door panels, handle inserts and top grille panels**

Door and top grille panels:  
Dimensions shown are with rounded edges. Routing is required if panels are more than 1/4" thick.

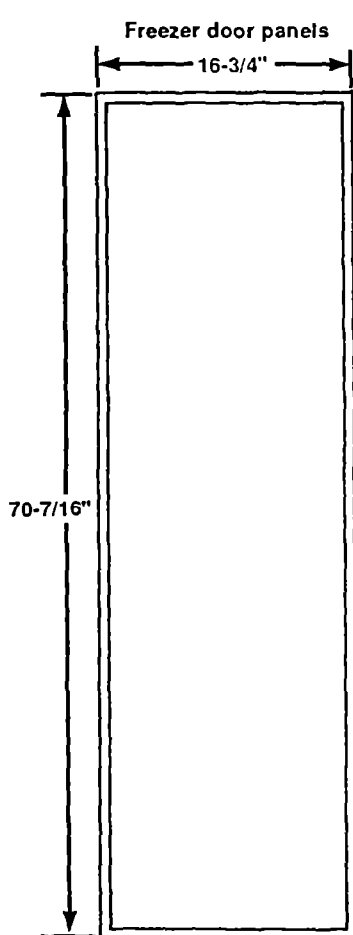

Maximum weight of custom panels is 30 pounds.

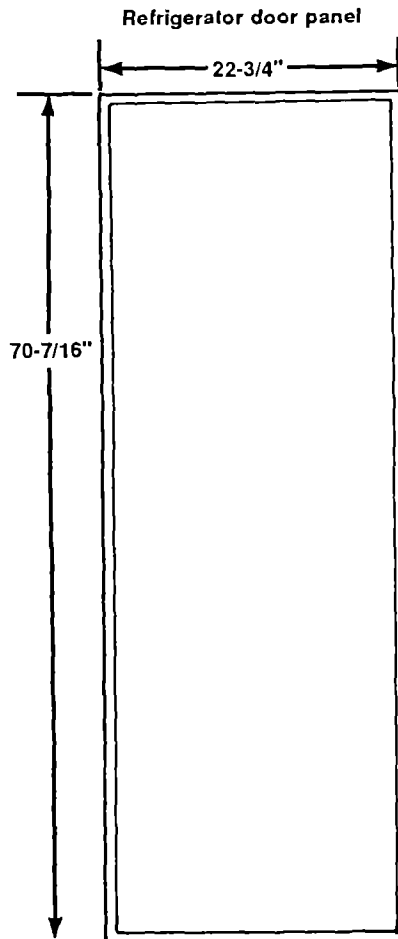

Maximum weight of custom panel is 50 pounds.

**Panel routing for door and top grille panels.**

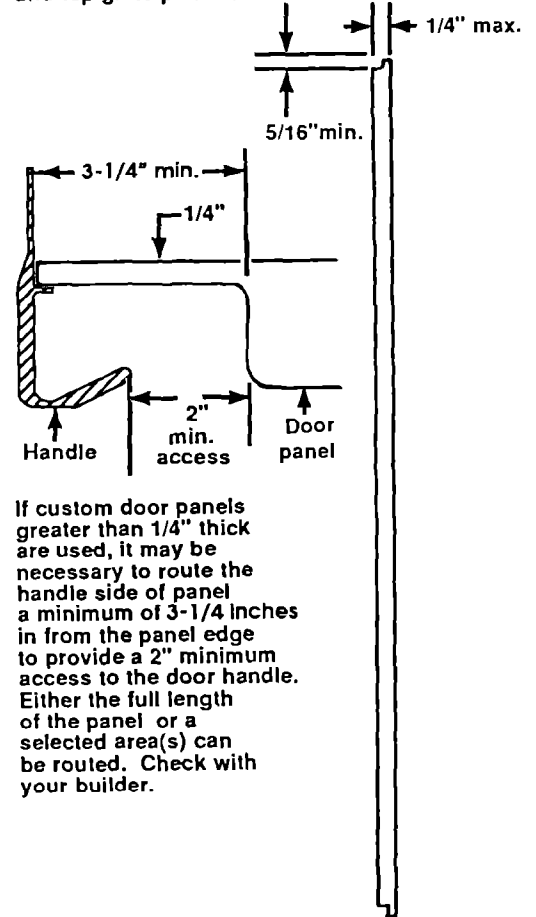

If custom door panels greater than 1/4" thick are used, it may be necessary to route the handle side of panel a minimum of 3-1/4 inches in from the panel edge to provide a 2" minimum access to the door handle. Either the full length of the panel or a selected area(s) can be routed. Check with your builder.

**CAUTION**

The weight of decorative panels **MUST NOT** exceed the weights specified for each panel. Panels weighing more than the specified weights may cause product damage.

**Top grille panels.**

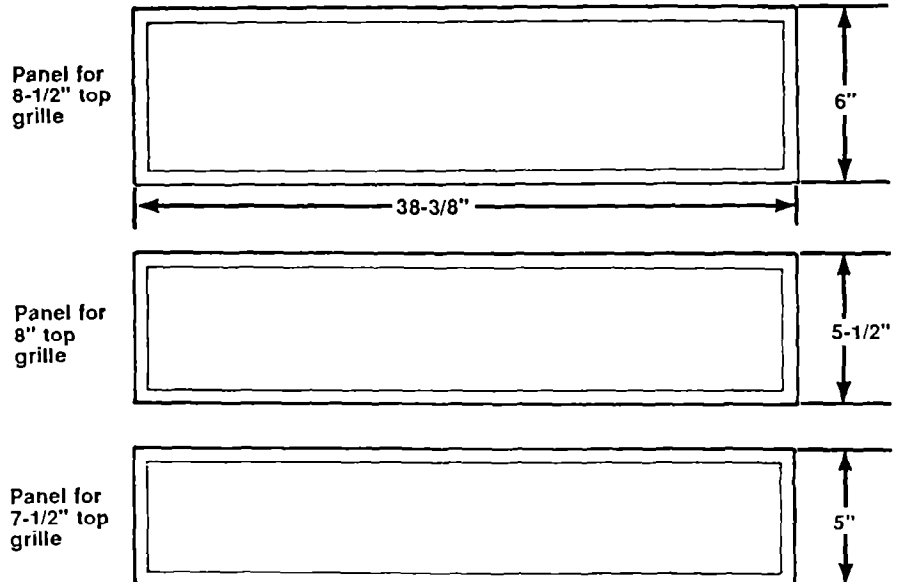

Maximum weight of custom panel is 10 pounds.

All dimensions +/- 1/16" tolerance  
Note: If a routed panel is used, add 1/16" to all dimensions shown.

# Product dimensions +/- 1/8" tolerance

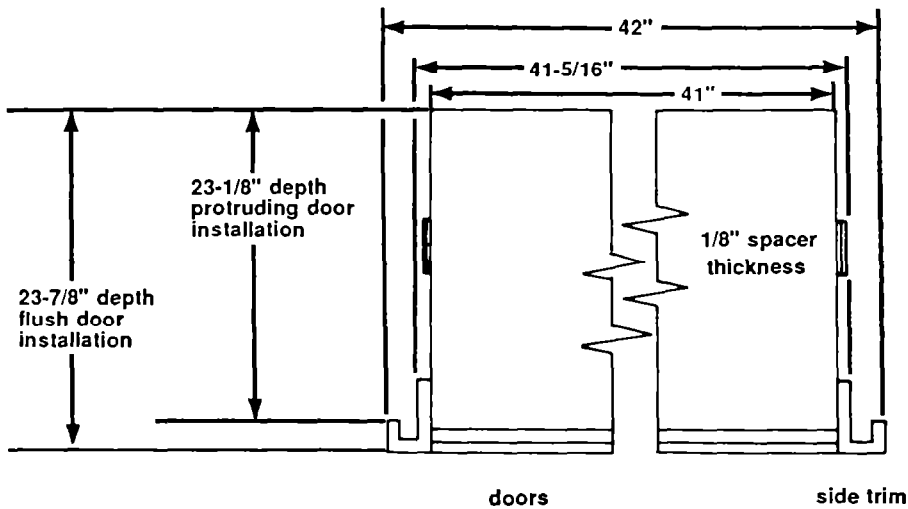

Refrigerator

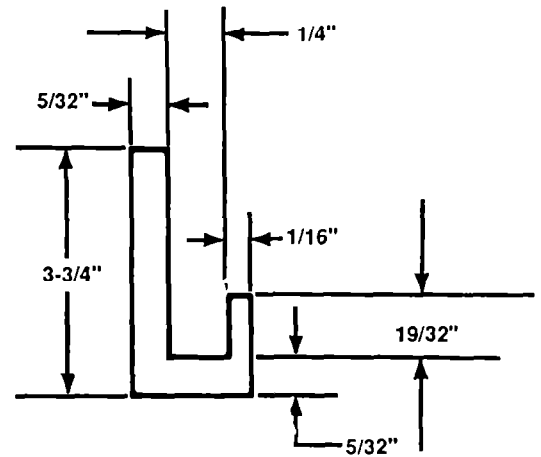

Side trim

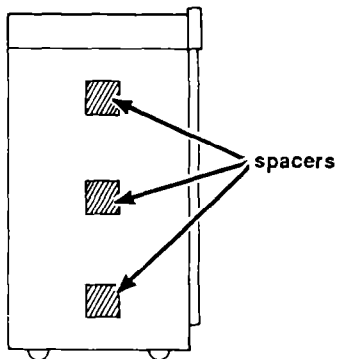

when 25" depth is available. If less than 25" depth is available, go to step 3.

If side panel is not inserted into side trim, drill six equally-spaced holes in each side trim as shown. **Do Not drill into side of cabinet.** Attach side panels to side trim using six screws on each side.

Side panel thickness should be 1/2" minimum to prevent "blousing" or warping.

completed according to each site's restrictions.

One method is to attach side panel to outside of side trim. However, this will increase width required. Drill holes into side trim. Attach a wood support to side trim. Attach side panel to panel support nailer and wood support. Cover wood support with a panel piece to match side panel.

1. Attach three spacers from the miscellaneous parts bag to the top, middle and bottom of each side of the refrigerator. Spacers are required for ventilation.

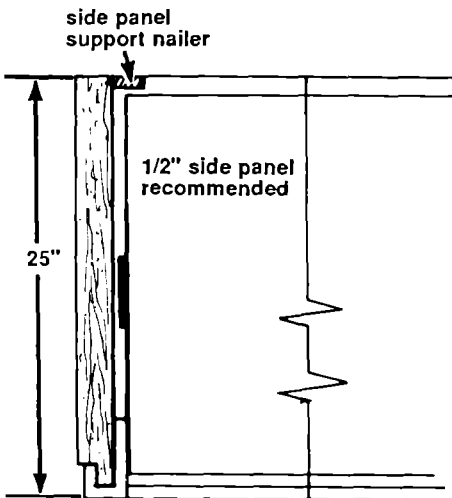

2. A side panel support nailer should be attached to the rear wall on each side of refrigerator

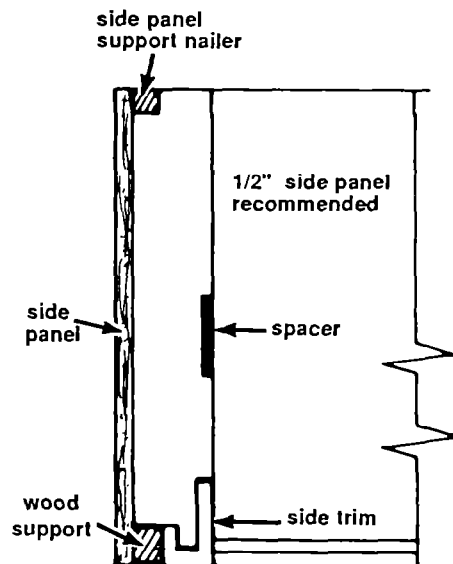

3. If less than 25" depth is available, side panel installation will need to be

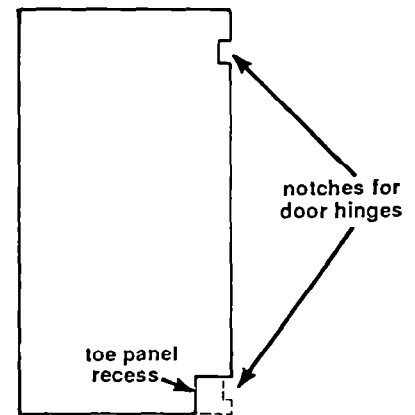

4. Height of side panels depends on your installation site. Side panels may need to be notched to clear door hinges. Side panels may be cut to match toe panel recess if desired.

**Notch side panel only after the installed height of the refrigerator has been determined.**

# Electrical requirements

## ⚠ WARNING

### Electrical Shock Hazard

- Improper connection of the equipment-grounding conductor can result in a risk of electrical shock. Check with a qualified electrician or service technician if you are in doubt as to whether the appliance is properly grounded.
- Do Not use an extension cord with this appliance. Such use may result in a fire, electrical shock, or other personal injury.

A 120-volt, 60-Hz, AC only, 15-or-20 ampere, fused, electrical supply is required. A time-delay fuse or circuit breaker is recommended. It is recommended that a separate circuit serving only this appliance be provided.

### Recommended grounding method

**DO NOT, UNDER ANY CIRCUMSTANCES, REMOVE THE POWER SUPPLY CORD GROUNDING PRONG.**

For your personal safety, this appliance must be grounded. This appliance is equipped with a power supply cord having a 3-prong grounding plug. To minimize possible shock hazard, the cord must be plugged into a mating 3-prong, grounding-type wall receptacle, grounded in accordance with the National Electrical Code, ANSI/NFPA 70-latest edition, and local codes and ordinances. See Figure 1. If a mating wall receptacle is not available, it is the personal responsibility and obligation of the customer to have a properly grounded, 3-prong wall receptacle installed by a qualified electrician.

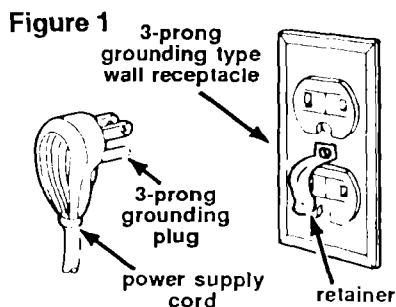

# Water supply requirements

Use only 1/4" copper tubing for water line.

The water line to the refrigerator must provide 15-100 psi water pressure.

The preferred method of installing the plumbing to the refrigerator is through the wall. An optional method is installing the water line through a floor opening. If the copper tubing is installed through the floor, the hole cut in the floor must be angled 45° toward the front.

You will need enough 1/4"- copper tubing to connect from water line to refrigerator, a saddle-type valve and a union. Rough in the water line before installing the refrigerator. See steps that follow.

## ⚠ CAUTION

### Product/Property Damage

Do Not install copper tubing in an area where temperatures drop below freezing.

To do so may result in water damage.

1. Find a 3/8" to 1" vertical cold water line near the refrigerator. Measure the distance from the cold water line to the refrigerator location. Add 24 inches for the final length of copper tubing you will need. Cut both ends of copper tubing square.
2. Turn off main water supply and clear water line.

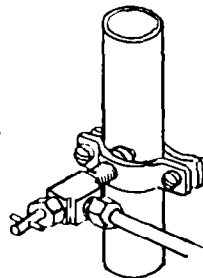

## ⚠ WARNING

### Electric Shock Hazard.

Electric drill must be grounded to prevent severe or lethal shock if water is in line and enters drill during use. Failure to ground drill may result in personal injury.

3. Ground electric drill or use a hand drill. Drill a 3/16" hole in vertical cold water line. Attach a saddle valve to the water line with a clamp in an easily accessible location. Insert a washer between clamp and line. Check that inlet end is solidly in the drill hole. Tighten packing nut. Tighten the pipe clamp screws evenly so washer makes a watertight connection. Do Not overtighten or copper tubing could be crushed.
4. Slide compression nut and sleeve on copper tubing. Insert end of copper tubing completely into the outlet valve. Tighten compression nut to outlet with an adjustable wrench. Do Not overtighten.

## ⚠ CAUTION

### Product Damage

Flush at least 2 qts. of water through the copper tubing and into a bucket before attaching to the refrigerator to get rid of any particles in water line. Check for water leaks around the saddle valve.

Failure to do so may result in product damage.

5. Run water through water line, valve and copper tubing into a bucket to flush out any particles in the water line. Turn the saddle valve to the "OFF" position.
  6. Route copper tubing to the refrigerator location.
- 
7. Slide compression nut and sleeve over water line.
  8. Connect union to compression nut and sleeve and tighten. Do Not overtighten.

# Product support

A solid soffit or a wood block is required to prevent the refrigerator from tipping forward after it is installed.

Determine what height the refrigerator will be when it is installed to fit opening. Determine the height to the top of the cover at the final installed height you plan to use.

**! WARNING**

**Personal Injury/Property Damage Hazard**

- Unit is top-heavy and may tip forward when the doors are opened.
- A solid soffit or 2" wood block is required above the refrigerator to prevent tipping during use.
- If solid soffit is more than 1 inch above refrigerator, a wood block must be installed on the wall not more than 1/4 inch above the refrigerator cover.

Failure to follow these instructions could result in personal injury or property damage.

Your installation location may vary from the examples shown. However, you must support the refrigerator with a wood block or other adequate means of support located 1/4" above the cover.

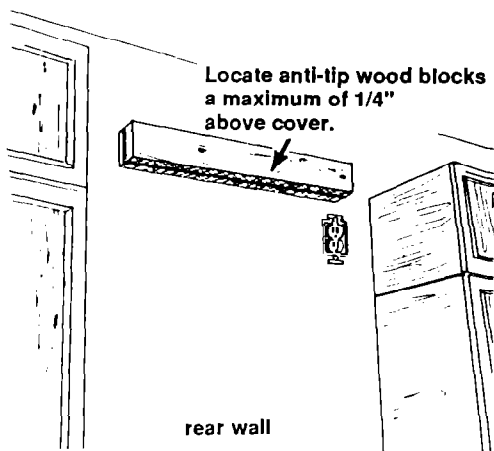

When a soffit is not available, locate wall studs in the refrigerator opening. Center one wood block and use wood screws to attach the wood block to the wall studs. Make sure screws engage wall studs a minimum of 1-1/2". Screw the second wood block to the front of the first block. The wood blocks must extend 2 inches beyond the ends of the cover.

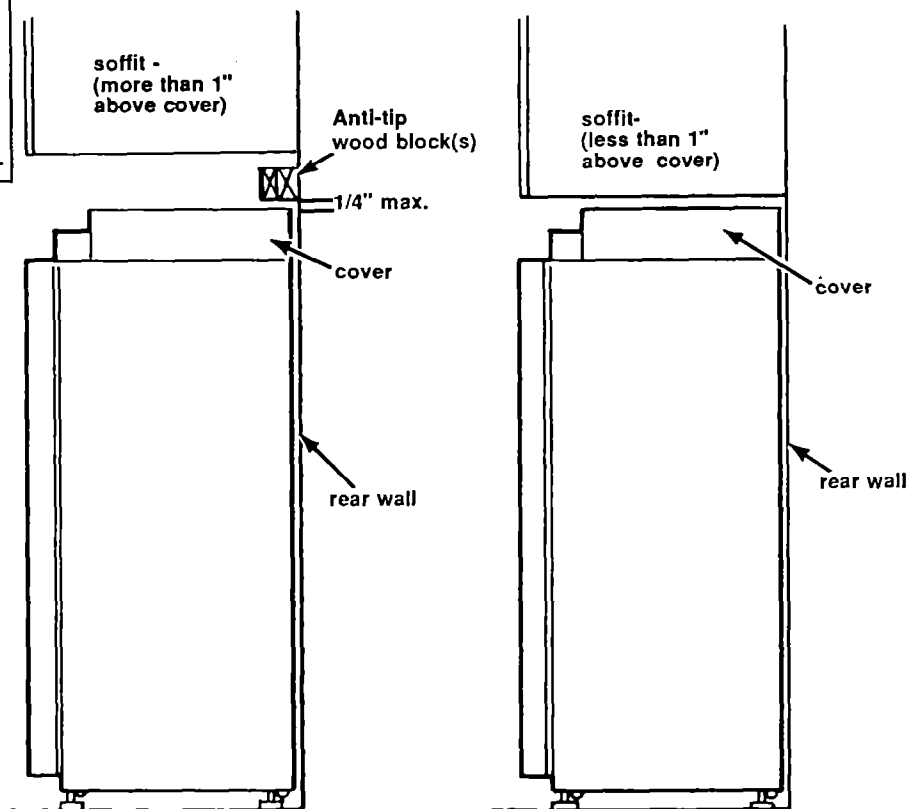
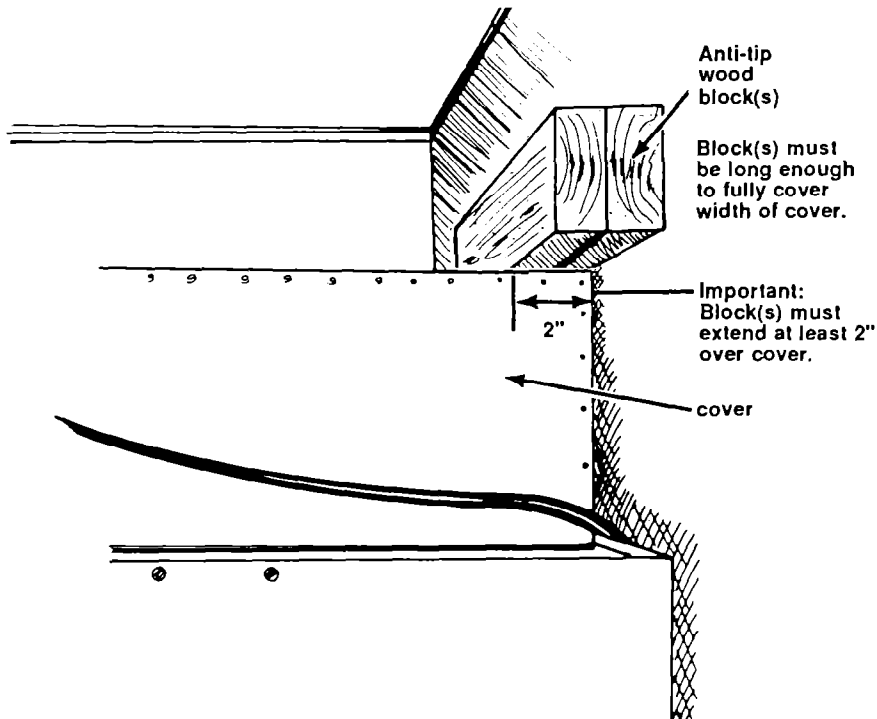

If soffit is more than one inch above cover, locate wall studs in the refrigerator opening. Center one wood block and use wood screws to attach the wood block to the wall studs. Make sure screws engage wall studs a minimum of 1-1/2". Screw the second wood block to the front of the first block. The wood block(s) must extend 2 inches beyond the ends of the cover.

If soffit is less than one inch above cover, a wood support is not needed.



## Now start...

1. Remove top grille assembly package, literature package and parts bag taped to the refrigerator door and save.

### CAUTION

**Product Damage**  
Do Not lower refrigerator against shipping base when removing the shipping base. Lowering the refrigerator against the shipping base could damage the components on the bottom of the refrigerator.

**Floor Damage**  
Keep cardboard shipping piece or plywood under refrigerator until it is installed in operating position. Failure to do so may cause damage to floor covering.

2. Remove the four brackets (2 on each side) that attach shipping base to the bottom of the refrigerator. Discard brackets and shipping base. Do Not remove tape and door bracing at this time.

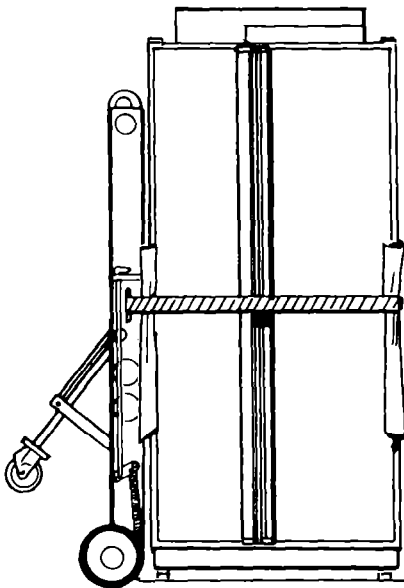

3. Place appliance dolly under the side of the refrigerator. Wrap strap from truck loosely around refrigerator. Insert two corner posts around handles to prevent scratching. Insert two corner posts over the cabinet side trim to prevent damage. Tighten strap making sure that handles and cabinet side trim will be protected.

### WARNING

#### Personal Injury Hazard

- Because of the weight and size of the built-in refrigerator, two or more people are needed to move and safely install it.
- Most of the refrigerator's weight is at the top. Extra care is needed when moving the refrigerator to prevent tipping.

Failure to do so could result in personal injury.

4. Move refrigerator to kitchen. Place cardboard or plywood under refrigerator. Remove appliance dolly. Open doors and remove all boxes, parts packages and packing materials from inside refrigerator and freezer compartments. Set aside until needed during installation.

Do Not remove any protective film until refrigerator is completely installed.

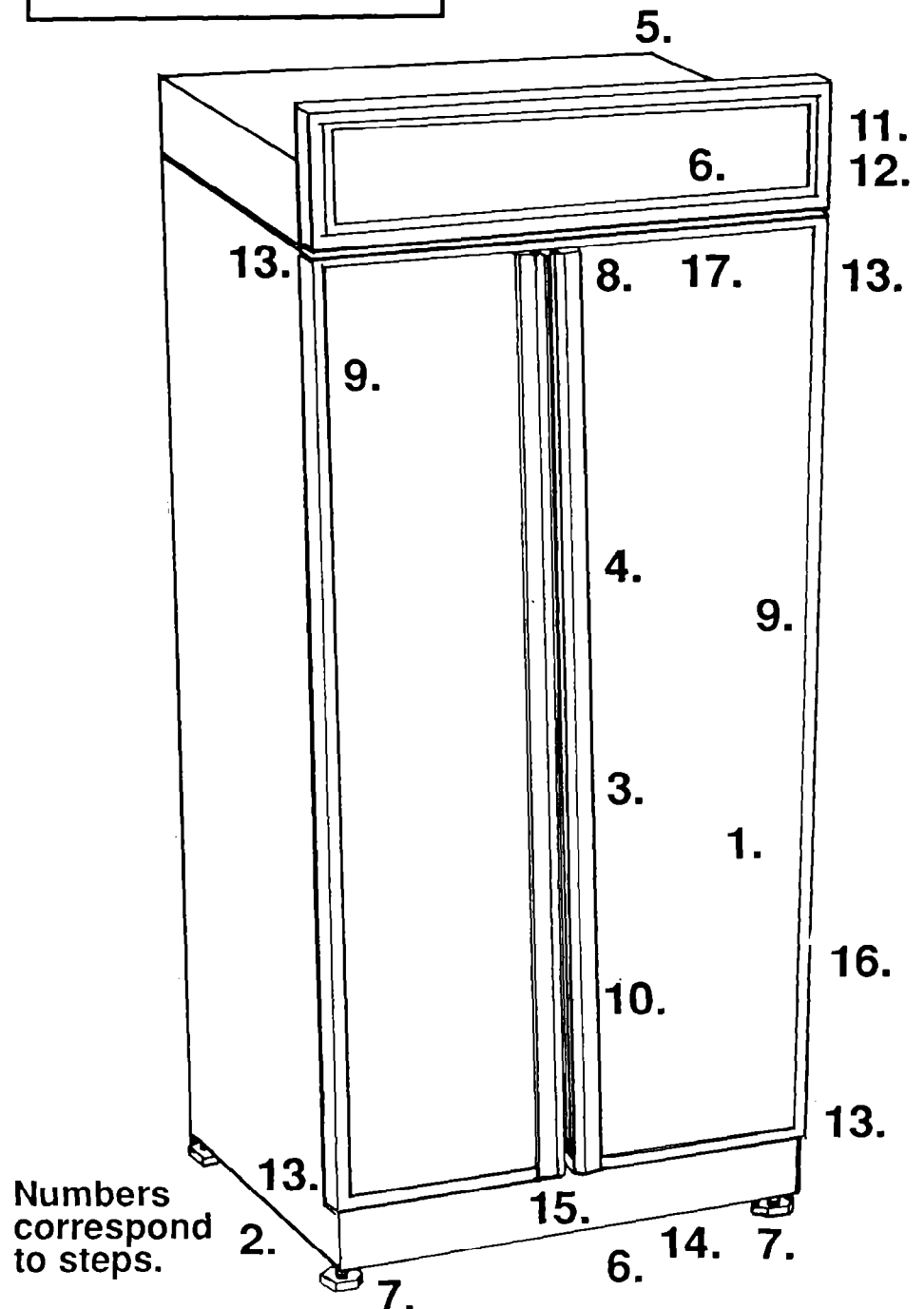

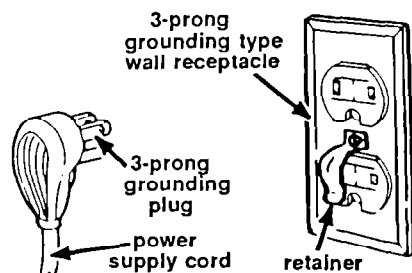

**5.** Move refrigerator close to final position. Remove cardboard or plywood from under refrigerator. Plug electrical cord into the grounded outlet. Use the screw from the parts package to install the plug retainer. Move the refrigerator evenly and straight into the opening. Check that the water line will not be kinked. Check that slack in the electrical cord hangs freely behind refrigerator or is placed on top of refrigerator next to cover.

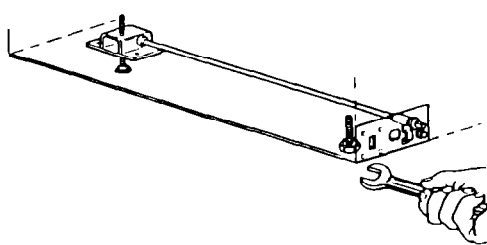

**7.** Remove tape from rear leveling rods. Turn the two leveling rods clockwise using a 5/16" socket and ratchet until the cabinet weight is supported by the rear legs. Use 1-3/8" open end wrench to lower the front leveling legs until the weight of the cabinet is supported by legs.

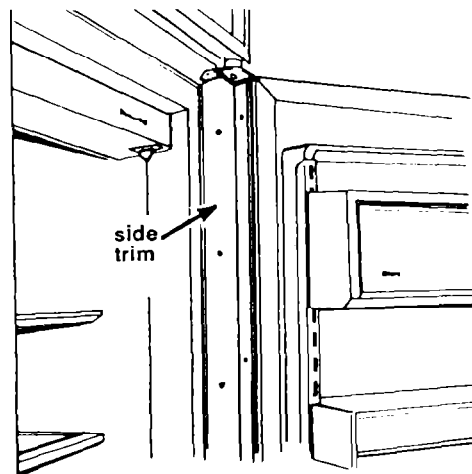

**9.** If side panels are not used, go to Step 10. Read Side panel requirements, page 6, before attaching side panels to refrigerator.

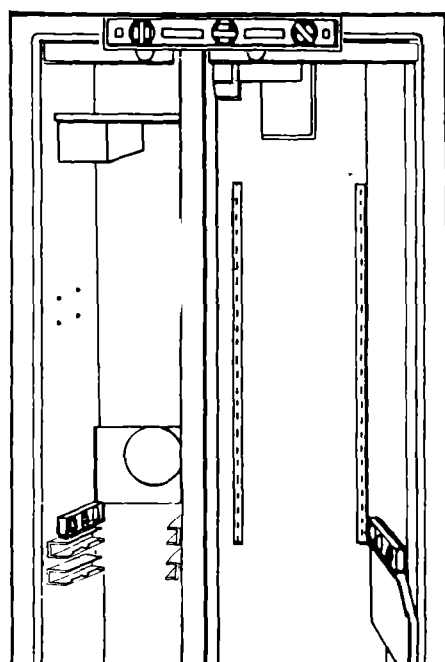

**Refrigerator must be level for proper operation.**

**Important:**

**All four leveling legs must contact the floor to support and stabilize the full weight of the refrigerator.**

**8.** Open both doors. Place a level against the underside of the door trim at the top of the refrigerator. Adjust the front leveling legs until level and to the right height for the recessed area. Place the level on the crisper guide in the refrigerator section to check for levelness front to back. Turn the right, rear leveling rod until level and to the required height. Place the level on the freezer basket guide to level the left side of the cabinet.

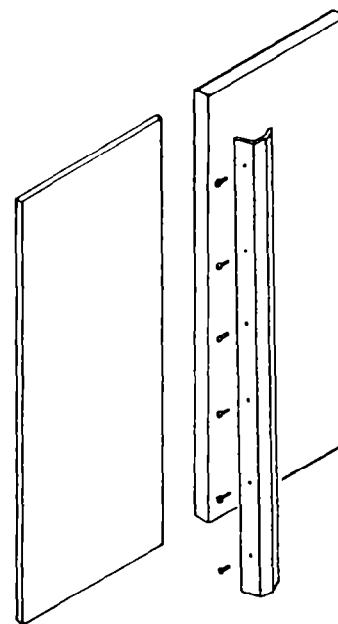

**10.** Remove all tape and door bracing from refrigerator door. Remove the six screws that attach the handle to the door frame. Slide the refrigerator door panel into door frame. If the panel is less than 1/4" thick, a filler panel will need to be installed between the door and decorative panel. If the decorative panel is more than 1/4" thick, it will have to be routed to have a 1/4" edge on all sides. See Custom panel and insert dimensions for exact sizes to cut custom panels.

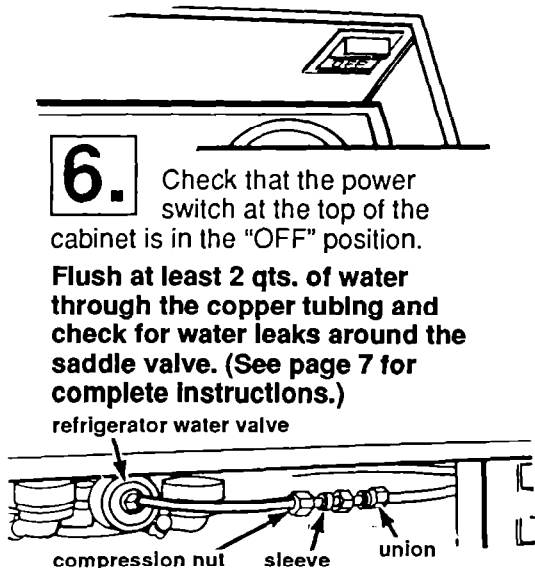

**6.** Check that the power switch at the top of the cabinet is in the "OFF" position.

**Flush at least 2 qts. of water through the copper tubing and check for water leaks around the saddle valve. (See page 7 for complete instructions.)**

refrigerator water valve

Connect tubing assembly fitting to refrigerator water valve. Do Not overtighten. (If necessary, water valve can be removed from underside of the cabinet to attach the fitting. You may have to remove the wiring channel to get to valve. Remove the screw between coils of water valve. Remove disconnected water valve and attach fitting. Replace the water valve.)

Slide compression nut and sleeve on open end of tubing assembly fitting. Connect the union from water supply line to compression nut and sleeve on the tubing from water valve and tighten. Do Not overtighten.

Turn water supply valve to the open position. Turn refrigerator switch to the "ON" position. Check all connections for leaks.

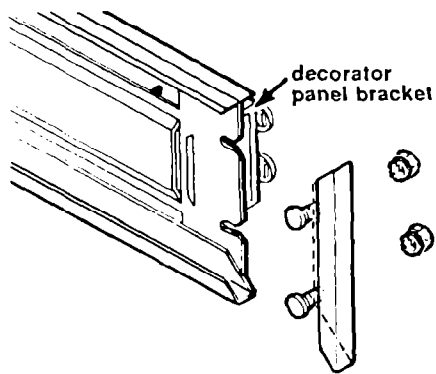

- 11.** Remove two nuts from one end of the top panel frame. Remove end piece. Slide decorative panel into panel frame. Replace end piece using nuts.

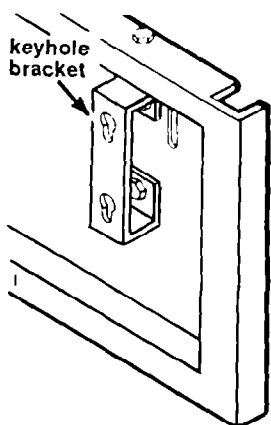

- 12.** Check that top grille is aligned with top trim on cabinet. Use six screws to tighten top grille frame to refrigerator. Check that the power switch is in the "ON" position. Attach top grille decorative panel assembly to the keyhole bracket on the frame and pull down to secure. If the top grille decorative panel does not fit evenly within frame, the keyhole bracket can be moved side to side by adjusting the bracket screws or the decorative panel bracket can be moved up or down by adjusting the decorator panel bracket nuts.

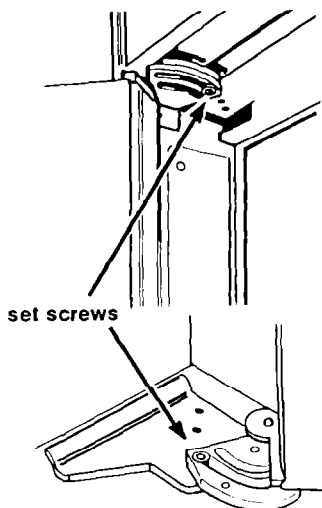

**⚠ WARNING**

**Personal Injury Hazard**  
Reinstall set screws after door swing is set.  
Failure to do so could result in personal injury.

- 13.** Check that doors can open freely. If not, the door stops or hinges can be adjusted.  
**To adjust horizontally:** Loosen set screw in top and bottom hinges with Allen wrench. Determine the door swing desired. Hold door in that position and tighten the set screws. The doors have stops at 90°, 115° and 137° positions. If the door stops cannot be adjusted to clear countertops, the countertops may need to be mitered. (Consult your builder to adjust countertops.)  
**To adjust vertically:** Loosen, do not remove, top and bottom hinge screws. Lift door and bottom hinge to desired position. Tighten bottom hinge screws and then top hinge screws.

- 14.** Check the water connections at the bottom of the refrigerator again for leaking. Any leaking can cause refrigerator and floor damage.

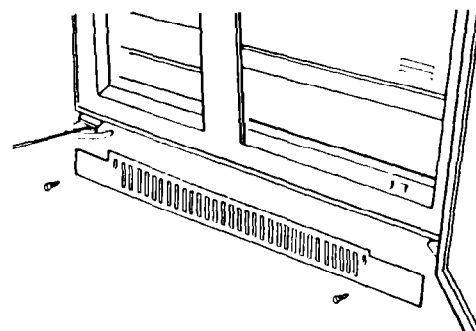

- 15.** Open both doors. Use two screws to attach bottom grille to cabinet.

- 16.** Put shelves and bins into the refrigerator and freezer compartments. Remove protective film from door frame.

- 17.** Set refrigerator and freezer compartment controls to the midpoint between "COLD" and "COLDEST". Check that the compressor is operating properly. Check that all five interior lights are working.

***To get the most efficient use from your new built-in refrigerator, read your KitchenAid® Use and Care Guide. Keep Installation Instructions and Guide close to built-in refrigerator for easy reference.***

## **If built-in refrigerator does not operate...**

Check that the circuit breaker is not tripped or house fuse blown. Check that power supply cord is plugged into wall receptacle. A more detailed troubleshooting checklist is provided in the Use and Care Guide.

## **If you need assistance...**

The KitchenAid Consumer Assistance Center will answer any questions about operating or maintaining your built-in refrigerator not covered in the Installation Instructions. The KitchenAid Consumer Assistance Center is open 24 hours a day, 7 days a week. Just dial 1-800-422-1230 — the call is free.

When you call, you will need the refrigerator model number and serial number. Both numbers can be found on the serial/rating plate located on the frame of the cabinet.

## **How to arrange for service...**

In the event that your KitchenAid appliance should need service, call the dealer from whom you purchased the appliance or a KitchenAid-authorized service company. A KitchenAid-authorized service company is listed in the Yellow Pages of your telephone directory under "Appliances — Household — Major — Service or Repair". You can also obtain the service company's name and telephone number by dialing, free, within the continental United States, the KitchenAid Consumer Assistance Center telephone number, 1-800-422-1230. A special operator will tell you the name and number of your nearest KitchenAid-authorized service company.

Maintain the quality built into your KitchenAid appliance — call a KitchenAid-authorized service company.