

# **Memorex®**

**MINI SYSTEM DIGITAL AM/FM 5 CD CHANGER  
DUAL CASSETTE RECORDER  
WITH TURNTABLE AND REMOTE CONTROL**

**MODEL: MX5520SPKA**

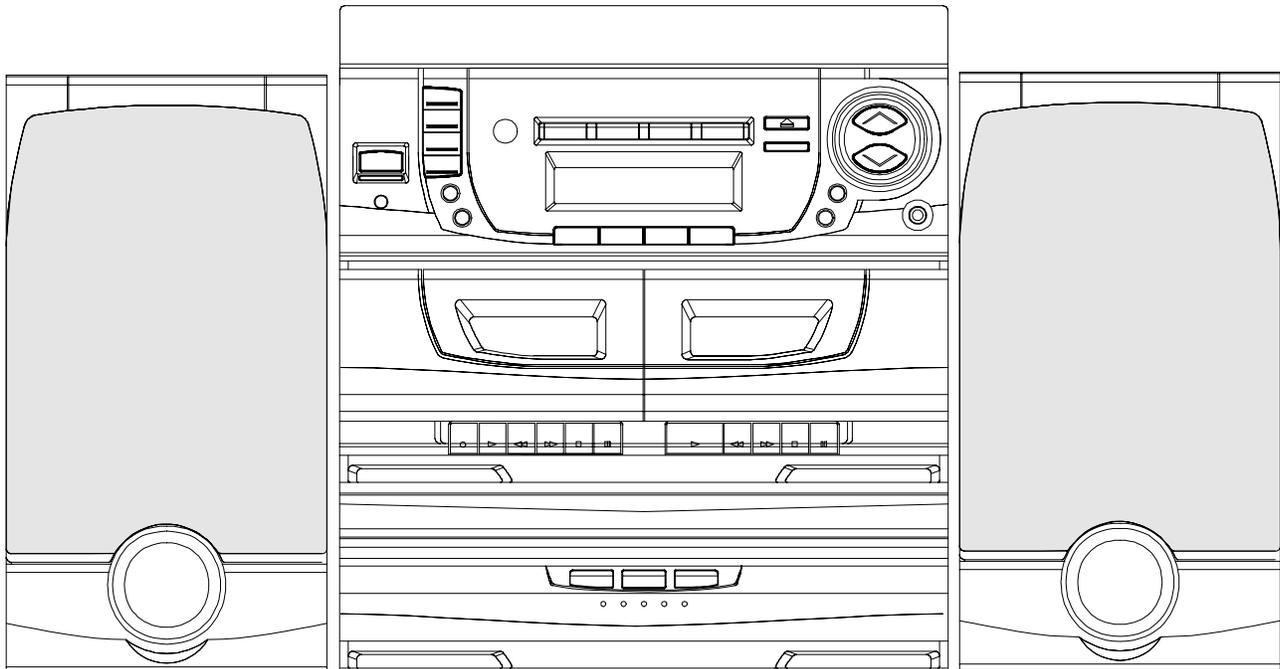

**BEFORE OPERATING THIS PRODUCT,  
PLEASE READ THESE INSTRUCTIONS COMPLETELY**

## IMPORTANT SAFEGUARDS

### CAUTION:

- Read all of these instructions.
- Save these instructions for later use.
- Follow all warnings and instructions marked on the audio equipment.

#### 1. READ INSTRUCTIONS

All the safety and operating instructions should be read before the product is operated.

#### 2. RETAIN INSTRUCTIONS

The safety and operating instructions should be retained for future reference.

#### 3. HEED WARNINGS

All warnings on the product and in the operating instructions should be adhered to.

#### 4. FOLLOW INSTRUCTIONS

All operating and use instructions should be followed.

#### 5. WATER AND MOISTURE

The product should not be used near water, for example, near a bathtub, washbowl, kitchen sink, laundry tub, in a wet basement, or near a swimming pool, etc.

#### 6. CARTS AND STANDS

The product should be used only with a cart or stand that is recommended by the manufacturer.

- 6A. An appliance and cart combination should be moved with care. Quick stops, excessive force, and uneven surfaces may cause the appliance and cart combination to overturn.



#### 7. WALL OR CEILING MOUNTING

The product should be mounted to a wall or ceiling as recommended by the manufacturer.

#### 8. HEAT

The product should be situated away from heat sources such as radiators, heat registers, stoves, or other products ( including amplifiers ) that produce heat.

#### 9. VENTILATION

The product should be situated so that its location or position does not interfere with its proper ventilation. For example, the product should not be situated on a bed, sofa, rug, or similar surface that may block the ventilation openings; or, placed in a built-in installation, such as a bookcase or cabinet that may impede the flow of air through the ventilation openings.

#### 10. POWER SOURCES

The product should be connected to a power supply only of the type described in the operating instructions or as marked on the product.

#### 11. GROUNDING OR POLARIZATION

Precautions should be taken so that the grounding or polarization means of a product is not defeated.

#### 12. POWER-CORD PROTECTION

Power-supply cords should be routed so that they are not likely to be walked on or pinched by items placed upon or against them, paying particular attention to cords at plugs, convenience receptacles, and the point where they exit from the product.

#### 13. CLEANING

The product should be cleaned only as recommended by the manufacturer.

#### 14. POWER LINES

An outdoor antenna should be located away from power lines.

#### 15. OUTDOOR ANTENNA GROUNDING

If an outside antenna is connected to the receiver, be sure the antenna system is grounded so as to provide some protection against voltage surges an built up static charges. Section 810 of the National Electrical Code. ANSI/NFPA 70 provides information with respect to proper grounding of the mast and supporting structure, grounding of the lead-in wire to an antenna discharge unit, size of grounding conductors, location of antenna-discharge unit, connection to grounding electrodes, and requirements for the grounding electrode. See Figure.

EXAMPLE OF ANTENNA GROUNDING AS PER NATIONAL ELECTRICAL CODE

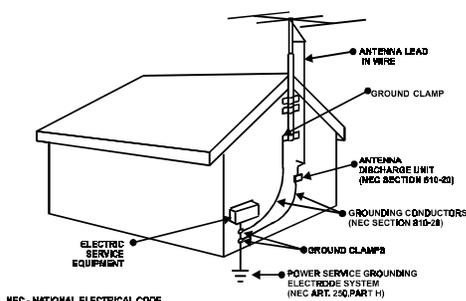

#### 16. NONUSE PERIODS

The power of the product should be unplugged from the outlet when left unused for a long period of time.

#### 17. OBJECT AND LIQUID ENTRY

Care should be taken so that objects do not fall and liquids are not spilled into the enclosure through openings.

#### 18. DAMAGE REQUIRING SERVICE

The product should be serviced by qualified service personnel when:

- A. The power-supply cord or the plug has been damaged; or
- B. Objects have fallen or liquid has been spilled into the product; or
- C. The product has been exposed to rain; or
- D. The product does not appear to operate normally or exhibits a marked change in performance; or
- E. The product has been dropped, or the enclosure damaged.

#### 19. SERVICING

The user should not attempt to service the product beyond that described in the operating instructions. All other servicing should be referred to qualified service personnel.

#### 20. NOTE TO CATV SYSTEM INSTALLER

This reminder is provided to call the CATV system installer's attention to Article 820-40 of the NEC that provides guidelines for proper grounding and, in particular, specifies that the cable ground shall be connected to the grounding system of the building, as close to the point of cable entry as practical.

### WARNING:

To reduce the risk of fire or electric shock, do not expose it is appliance to rain or moisture.

### CAUTION:

Use of controls or adjustments or performance of procedures other than those specified may result in hazardous radiation exposure.

## CAUTION

### RISK OF ELECTRIC SHOCK DO NOT OPEN

To reduce the risk of electric shock, do not remove cover (or back). No user serviceable parts inside. Refer servicing to qualified service personnel



The lightning flash with arrowhead symbol within an equilateral triangle, with an equilateral triangle, is intended to alert user to the presence of uninsulated "dangerous voltage" within the products enclosure that may be of sufficient magnitude to constitute a risk of electric shock to persons



The exclamation point within an equilateral triangle is intended to alert the user to the presence of important operating and maintenance ( servicing ) instruction in the literature accompanying the appliance.

### CAUTION

For Compact Disc Units only.



INVISIBLE LASER RADIATION WHEN OPEN AND INTERLOCK FAILED OR DEFEATED. AVOID DIRECT EXPOSURE TO LASER BEAM.

# TABLE OF CONTENTS

<b>INSTALLATION</b> .....	<b>2~5</b>
Accessories.....	2
Positioning Your Main Unit.....	2
Rear Panel Connections.....	3
Connecting the Speakers.....	4
Connecting Optional Equipment.....	5
<b>FUNCTIONAL OVERVIEW</b> .....	<b>6~11</b>
Front Panel.....	6 - 8
LCD Display.....	9
Remote Control.....	10-11
<b>AMPLIFIER</b> .....	<b>12</b>
General.....	12
<b>TIMER SETTING</b> .....	<b>12~13</b>
Clock Setting.....	12
Time On/Off Setting.....	12-13
Sleep Timer.....	13
<b>TURNTABLE</b> .....	<b>14</b>
Phono.....	14
<b>CD CHANGER</b> .....	<b>15~17</b>
Loading Disc Into The CD Tray.....	15
Disc Status.....	15
Normal CD Playback.....	15
CD Random Playback.....	16
CD Repeat Playback.....	16
Displaying Time Information.....	16-17
CD Program ( CD Memory ).....	17
<b>TAPE PLAYER</b> .....	<b>18~19</b>
Loading One Tape.....	18
Normal Playback ( Deck A and Deck B ).....	18
Recording ( Deck A ).....	18-19
Sequential Playback ( Deck B to Deck A).....	19
<b>TUNER</b> .....	<b>20</b>
Auto (automatic)/Manual Tuning.....	20
Preset Memory.....	20
<b>GENERAL INFORMATION</b> .....	<b>21~22</b>
Troubleshooting.....	21
System Specifications.....	22

## INSTALLATION

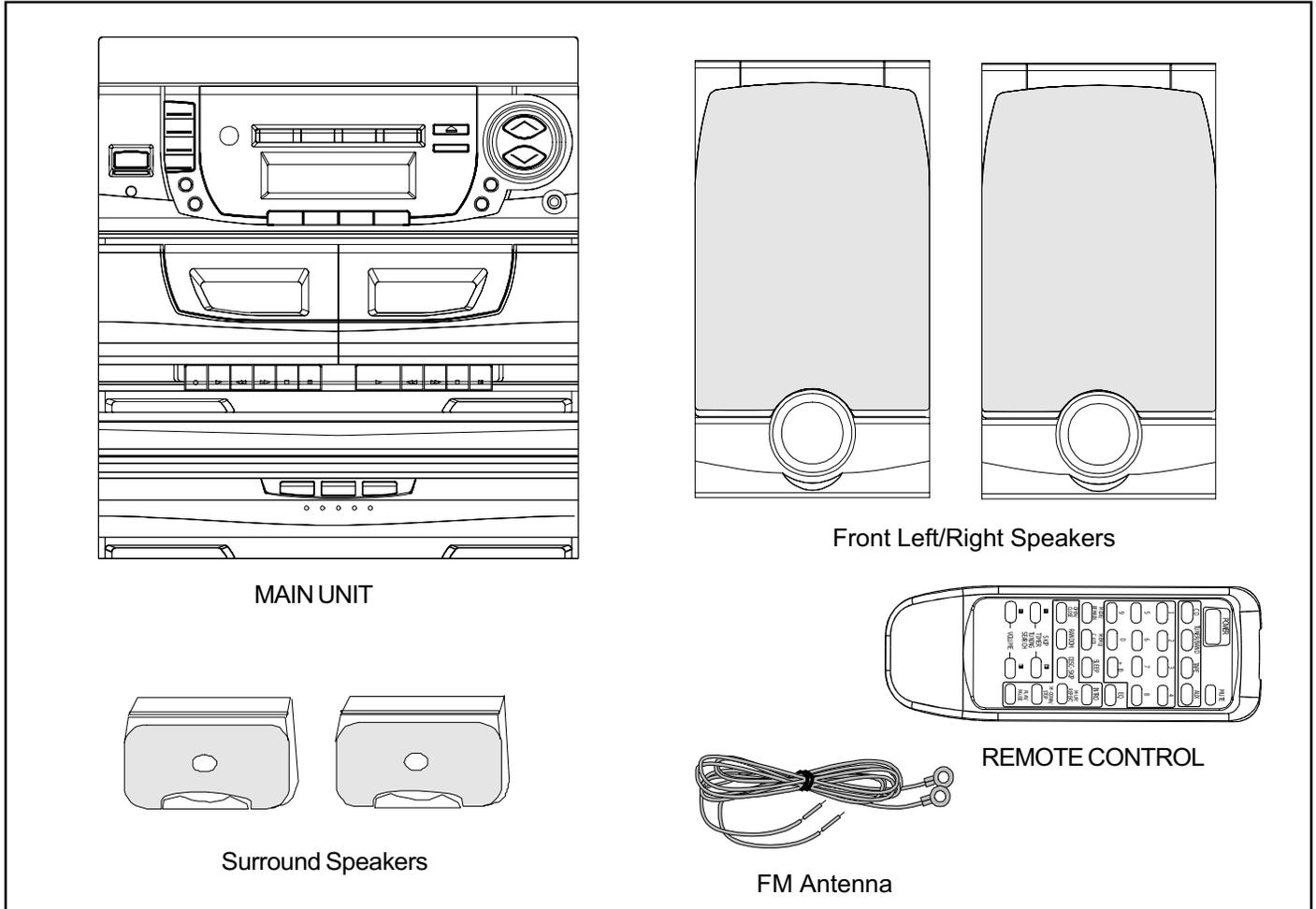

### ACCESSORIES

This package contains:

- 1 Main Unit
- 2 Front Speakers
- 2 Surround Speakers
- 1 FM Antenna
- 1 Remote Control
- 2 AA Batteries
- 1 Instruction book

### POSITIONING YOUR MAIN UNIT

Place the unit on stable, level surface, out of direct sunlight and away from sources of excessive dust, dirt, heat, water, moisture, vibration and strong magnetic fields.

Do not connect the unit to the AC power supply until all other connections have been made and the AC voltage (indicated on the type plate on the back cover) has been checked.

When positioning the unit, bear in mind that every receiver produces heat which must be able to dissipate freely. For this reason do not cover any vents and make sure that there is sufficient ventilation around the unit.

Always remove all CDs from the changer before moving the system.

# INSTALLATION

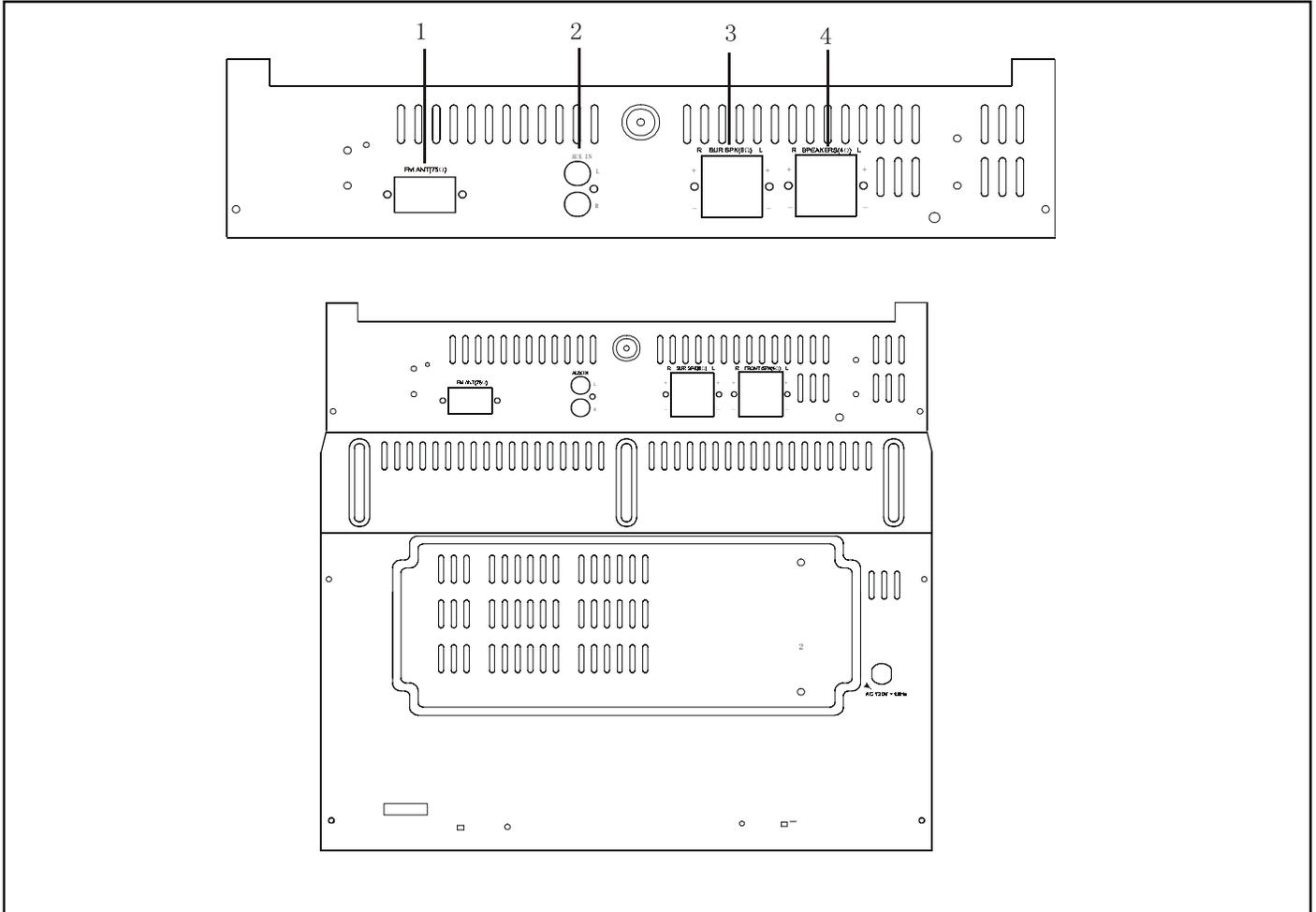

## REAR PANEL CONNECTIONS

### 1. FM ANTENNA (FM 75 OHM)

For connecting the 75 ohm antenna supplied.

### 2. AUX IN (L/R)

For connecting optional video equipment.

### 3. SURROUND SPEAKER (8 OHM)

Connect supplied left and right front surround speaker here.

### 4. FRONT SPEAKERS (4 OHM)

Connect supplied left and right front speakers here.

### 5. AC POWER CORD

Plug into a standard 120V/60Hz household wall outlet.

## CONNECTING THE FM ANTENNA

Plug the FM antenna to the FM terminal of the main unit.

## ANTENNA OR SPEAKER WIRE CONNECTION TO TERMINALS

**NOTE:** Push and hold speaker terminal tab down to insert wire. Release tab to lock wire in terminal. Make sure the insulation is completely removed from the ends of the antenna and speaker wires at all connection points.

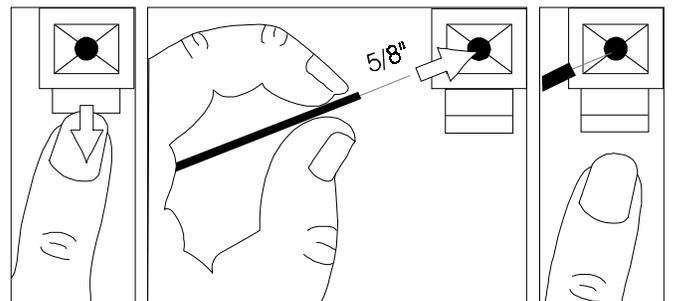

# INSTALLATION

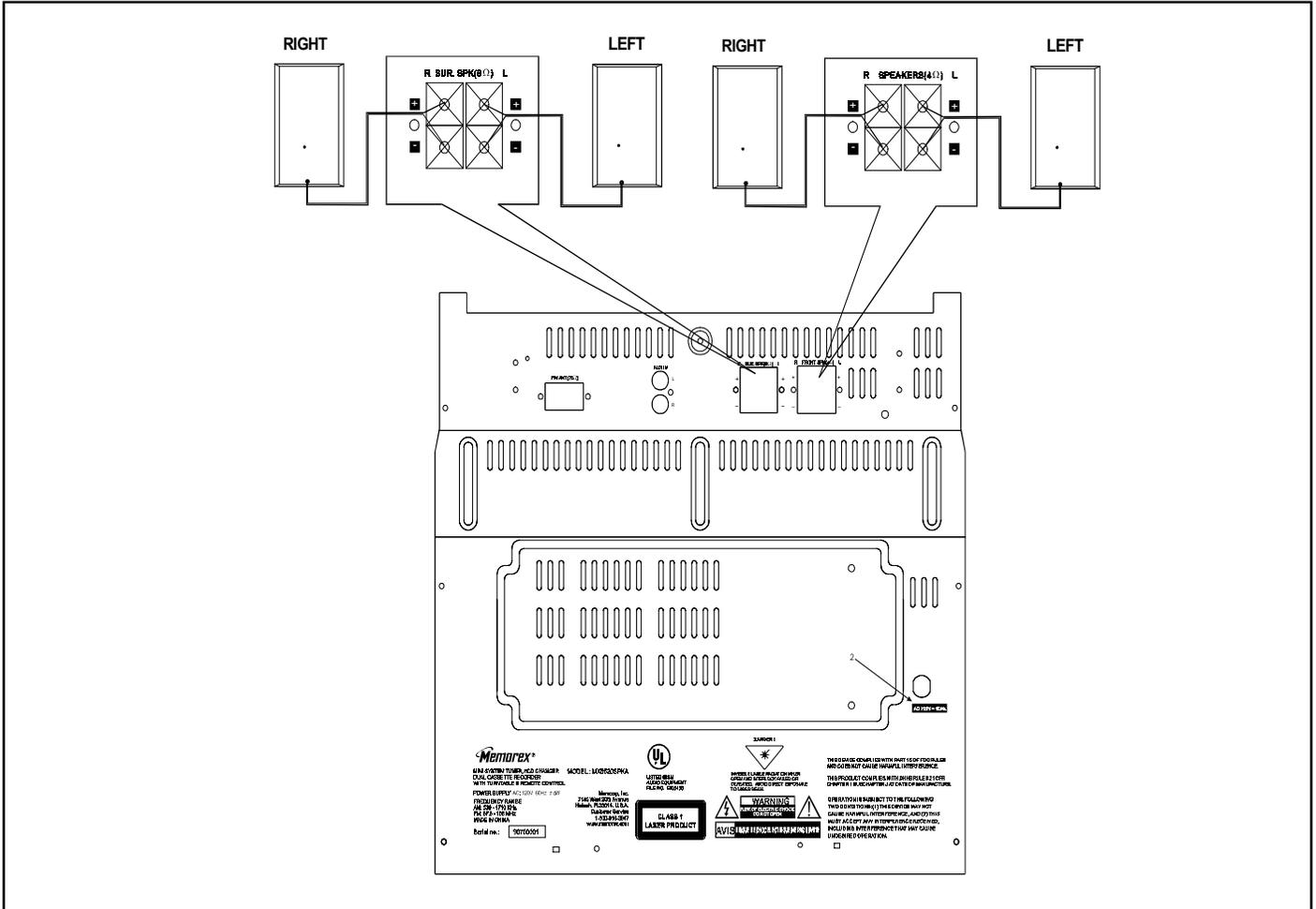

## CONNECTING THE SPEAKERS

**Connecting the Front Speakers**  
 Connect the right front speaker to the front speaker " R " terminal on the back of the main unit, and the left front speaker to the front speaker " L " terminal.

Make sure the (+) and (-) cables are connected to the correct front speaker terminals [(+) to (+) and (-) to (-)].

## CONNECTING THE SURROUND SPEAKERS

**Connecting the Surround Speakers**  
 Connect the right front speaker to the surround speaker " R " terminal on the back of the main unit, and the left front speaker to the surround speaker " L " terminal.

Make sure the (+) and (-) cables are connected to the correct surround speaker terminals [(+) to (+) and (-) to (-)].



# FUNCTIONAL OVERVIEW

FRONT PANEL

FRONT PANEL

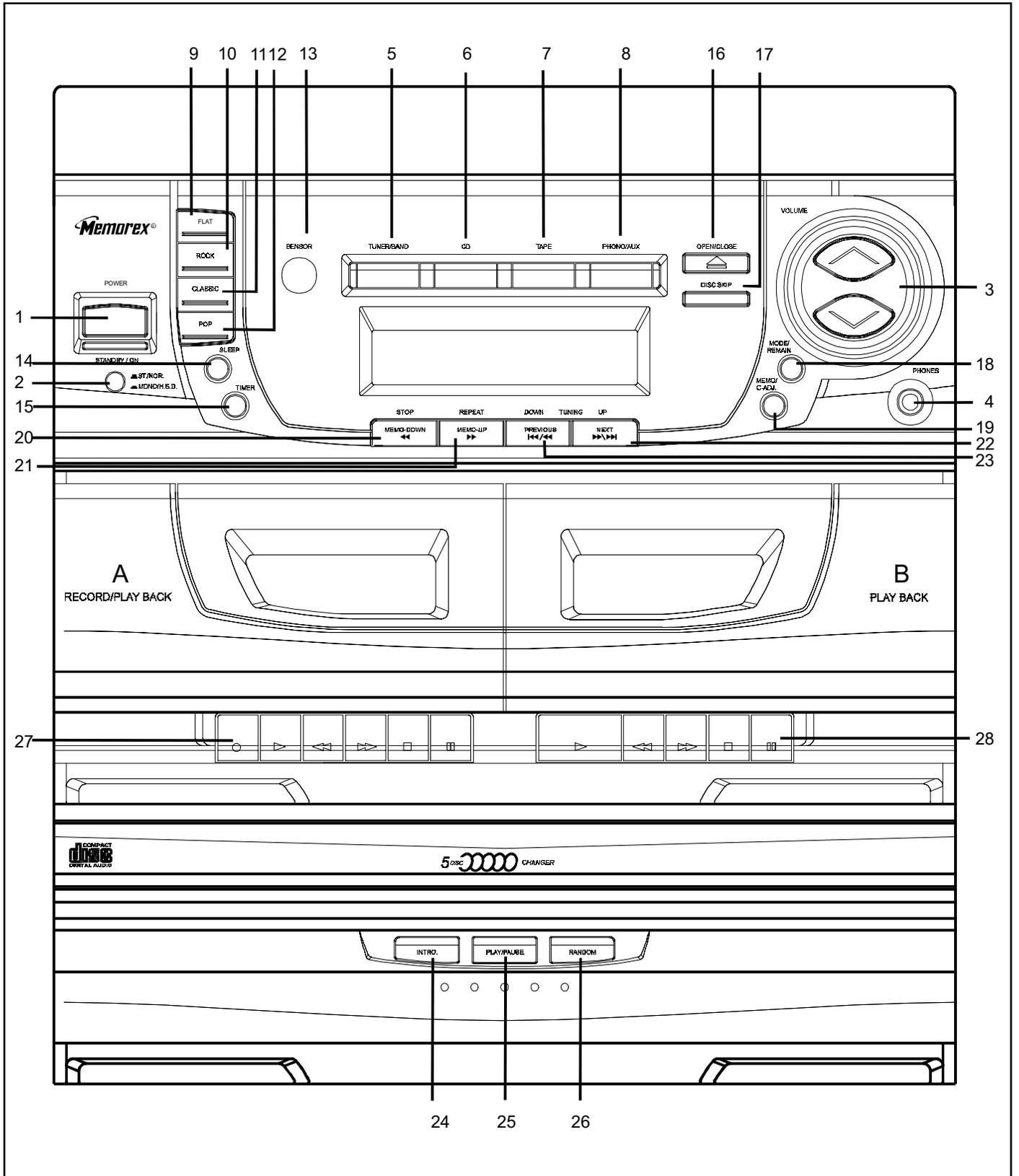



## FUNCTIONAL OVERVIEW

### FRONT PANEL

1. **POWER**  
Press the POWER button to switch the main power of the unit ON or STANDBY.
2. **■ ST. / NOR & ■ MONO. / H.S.D.**
  - In TAPE RECORD mode, press to select normal mode or to increase the TAPE recording speed to twice the normal recording speed.
  - In FM mode, press to select either STEREO sound or MONO sound.
3. **VOLUME**  
Press the volume buttons to adjust the volume level up or down.
4. **PHONES**  
Plug headphones into this jack. Press the volume button to adjust the sound level.
5. **TUNER / BAND**
  - Not in TUNER mode, press to set TUNER mode.
  - In TUNER mode, press to change the receiving BAND between FM and AM
6. **CD**
  - Not in CD mode, press to set CD mode.
  - In CD mode, it has the same function as the DISC SKIP key. Press to set or skip to next valid disc in ascending order.
7. **TAPE**  
Press to select the function of TAPE.
8. **PHONO / AUX**  
Press to select the PHONO function or the AUX input source. Both of PHONO and AUX are mixing-channel, you can listen a mixing sound if you play the PHONO and input other signal from the AUX at the same time.
9. **FLAT**  
Press to select FLAT sound mode.
10. **ROCK**  
Press to select ROCK sound mode.
11. **CLASSIC**  
Press to select CLASSIC sound mode.
12. **POP**  
Press to select POP sound mode.

### FRONT PANEL

13. **SENSOR**  
Infrared rays sensor, to receive the informations transmitted from the remote control.
14. **SLEEP**  
Press to select the SLEEP timer on or off. Keep pressing this key will set the sleep time from 00 to 90 minutes.
15. **TIMER**  
Press to set timer on or off. When timer is on,  will illuminate.
16. **OPEN / CLOSE**  
Press to open or close the CD door
17. **DISC SKIP**
  - In CD memory set mode, press to set to next valid disc number in ascending order.
  - In CD normal play or stop mode, press to skip to next valid disc in ascending order.
  - Not in CD mode, press to skip to next valid disc in ascending order when the door is open.
18. **MODE / REMAIN**
  - In TUNER mode, press to change the following display cyclically: Band and Frequency, Time display.
  - In CD normal play mode, press to change the following display cyclically: Each playing time, Each remaining time, Total remaining time, Total playing time, Time display.
  - In CD random play mode, press to change the following display cyclically: Each playing time, Each remaining time, Time display.
  - In CD memory play mode, press to change the following display cyclically: Each playing time, Each remaining time, Program number, Time display.
  - In CD stop mode, press to change the following display cyclically: All time display, Time display.
  - In TAPE or AUX mode, press to change the following display cyclically: AUX or TAPE, Time display.

**NOTE:** The above **Time display** including: Clock display, Time ON, Time OFF.
19. **MEMO / C-ADJ.**
  - In TUNER mode, press to store AM/FM stations in the memory locations.
  - In CD mode, press to do CD program in memory locations.
  - In clock adjust mode, press to set clock or timer adjustment.

## FUNCTIONAL OVERVIEW

### FRONT PANEL

#### 20. STOP / MEMO • DOWN

- In CD mode, press to stop CD playing and exit CD memory registration mode. When CD is stop, press this key to clear CD memory.
- In TUNER mode, press to call the preset memory in descending order.

#### 21. REPEAT / MEMO • UP

- In CD mode, press to change the following repeat play mode cyclically: All disc, Repeat all disc, Repeat one disc, Repeat one track.
- In TUNER mode, press to call the preset memory in ascending order.

#### 22. TUNING • DOWN / PREVIOUS

- In TUNER mode, press less than 0.5 second to do manual tuning in descending order.
- In TUNER mode, press longer than 0.5 second to do auto tuning in descending order.
- In CD mode, press less than 0.5 second to move track in descending order.
- In CD mode, when CD is playing, press longer than 0.5 second to search in descending order.
- In clock or timer adjusting enable state mode, press to adjust clock time in descending order.

#### 23. TUNING • UP / NEXT

- In TUNER mode, press less than 0.5 second to do manual tuning in ascending order.
- In TUNER mode, press longer than 0.5 second to do auto tuning in ascending order.
- In CD mode, press less than 0.5 second to move track in ascending order.
- In CD mode, when CD is playing, press longer than 0.5 second to search in ascending order.
- In clock or timer adjusting enable state mode, press to adjust clock time in ascending order.

#### 24. INTRO

Press to set or release the intro scan play mode in CD mode.

#### 25. PLAY / PAUSE

Press to begin playback of the CD and press again to pause CD playback.

#### 26. RANDOM

Press to toggle CD random play mode, the RANDOM indicator appears on the display and tracks on all discs are played in random order. When the last track of the

### FRONT PANEL

last disc is played, the system will automatically stop, unless you have selected REPEAT mode.

#### 27. [ DECK A ] CASSETTE FUNCTION KEYS

- ● RECORD ..... Press to activate cassette recording.
- ► PLAY ..... Press to activate cassette playing.
- ◀◀ REWIND ..... Press activate cassette rewinding.
- ►► F. FWD. .... Press to activate cassette fast for-warding.
- ■ STOP / EJECT ... Press once to stop play, rewind or fast forward. Press a second time to eject the cassette.
- || PAUSE ..... Press to pause playback.

#### 28. [ DECK B ] CASSETTE FUNCTION KEYS

- ► PLAY ..... Press to activate cassette playing.
- ◀◀ REWIND ..... Press activate cassette rewinding.
- ►► F. FWD. .... Press to activate cassette fast for-warding.
- ■ STOP / EJECT ... Press once to stop play, rewind or fast forward. Press a second time to eject the cassette.
- || PAUSE ..... Press to pause playback.

## FUNCTIONAL OVERVIEW

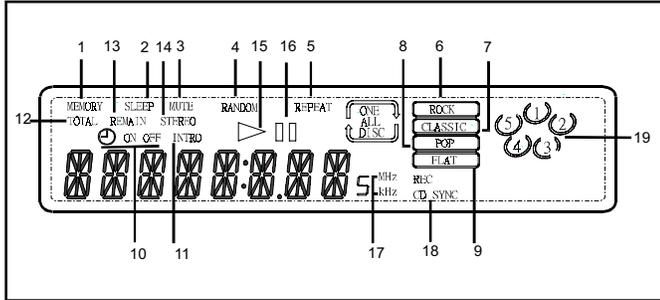

### LCD DISPLAY

1. **MEMORY**  
Illuminates if any track or station has been stored to a CD program or tuner memory in CD mode or TUNER mode.
2. **SLEEP**  
Illuminates if you select the SLEEP function.
3. **MUTE**  
Illuminates if you select the MUTE function.
4. **RANDOM**  
Illuminates if you select the random play function in CD mode.
5. **REPEAT**  
Illuminates if you select the repeat play function in CD mode.
6. **ROCK**  
Illuminates if the ROCK EQ mode is selected.
7. **CLASSIC**  
Illuminates if the CLASSIC EQ mode is selected.
8. **POP**  
Illuminates if the POP EQ mode is selected.
9. **FLAT**  
Illuminates if the FLAT EQ mode is selected.
10. **ON / OFF**  
 will illuminate if the Timer is on by pressing the TIMER button on the remote to select.  
 **ON** will flash if Time ON function is selected by pressing the MODE / REMAIN button on the remote repeatedly.

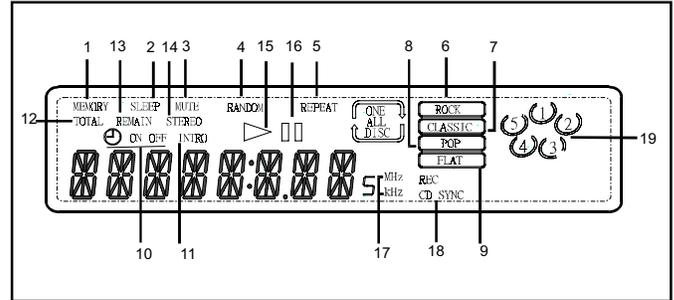

### LCD DISPLAY

11. **INTRO**  
Illuminates if you select the INTRO play function in CD mode.
12. **TOTAL**  
Illuminates if you select the total remain time or total time in CD normal play mode.
13. **REMAIN**  
Illuminates if you select the each remain time or total remain time in CD play mode.
14. **STEREO**  
Illuminates if a stereo signal is received in tuner mode.
15. **▶**  
Illuminates during CD playback mode.
16. **||**  
Illuminates when CD playback has been paused.
17. **MHz/KHz**  
Illuminates while the FM or AM station has been selected in TUNER mode.
18. **REC CD SYNC**  
Illuminates if the CD-SYNC tape recording function has been selected.
19. **DISC NUMBER**  
Illuminates if the corresponding tray has disc in CD mode. If the tray is read and not be sure having disc, the corresponding disc number will disappear from the LCD.

# FUNCTIONAL OVERVIEW

## REMOTE CONTROL

## REMOTE CONTROL

### INSTALLING BATTERIES:

1. Remove the battery cover from the back of the remote.
2. Insert 2XAA batteries into the remote. Ensuring correct (+) and (-) polarity as indicated in the battery compartment.
3. Replace the battery cover.

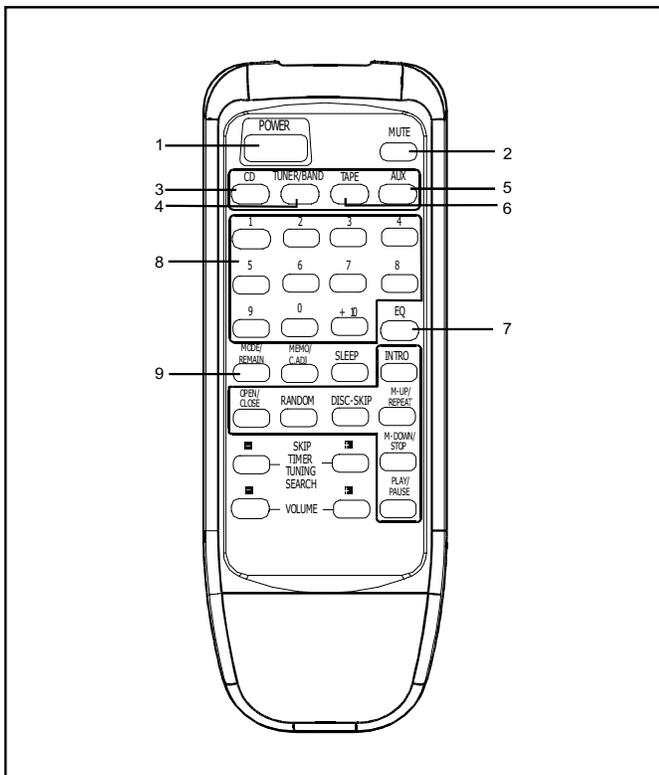
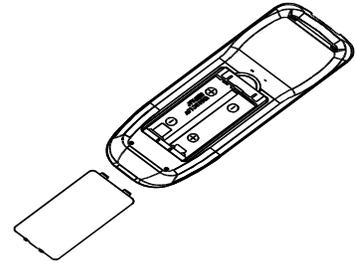

#### 1. POWER

Press the POWER button to switch the main power of the unit ON or STANDBY.

#### 2. MUTE

Press to cancel sound. Press again to return the sound to its previous level. The MUTE indicator will illuminate when the MUTE function is on.

#### 3. CD

- Not in CD mode, press to set CD mode.
- In CD mode, it has the same function as the DISC SKIP key. Press to set or skip to next valid disc in ascending order.

#### 4. TUNER/BAND

- Not in TUNER mode, press to set TUNER mode.
- In TUNER mode, press to change the receiving BAND between FM and AM.

#### 5. TAPE

Press to select the function of TAPE.

#### 6. PH. / AUX

Press to select the PHONO function or the AUX input source. Both of PHONO and AUX are mixing-channel, you can listen a mixing sound if you play the PHONO and input other signal from the AUX at the same time.

#### 7. EQ

Press EQ button repeatedly to cyclic select ROCK CLASSIC, POP or FLAT EQ setting, the adjacent indicator will illuminate.

#### 8. 0 - 9 / +10

- In CD mode, press to select favorite track.
- In TUNER mode, press to select favorite preset station.

#### 9. MODE / REMAIN

- In TUNER mode, press to change the following display cyclically: Band and Frequency, Time display.
- In CD normal play mode, press to change the following display cyclically: Each playing time, Each remaining time, Total remaining time, Total playing time, Time display.
- In CD random play mode, press to change the following display cyclically: Each playing time, Each remaining time, Time display.
- In CD memory play mode, press to change the following display cyclically: Each playing time, Each remaining time, Program number, Time display.
- In CD stop mode, press to change the following display cyclically: All time display, Time display.
- In TAPE or AUX mode, press to change the following display cyclically: AUX or TAPE, Time display.

# FUNCTIONAL OVERVIEW

## REMOTE CONTROL

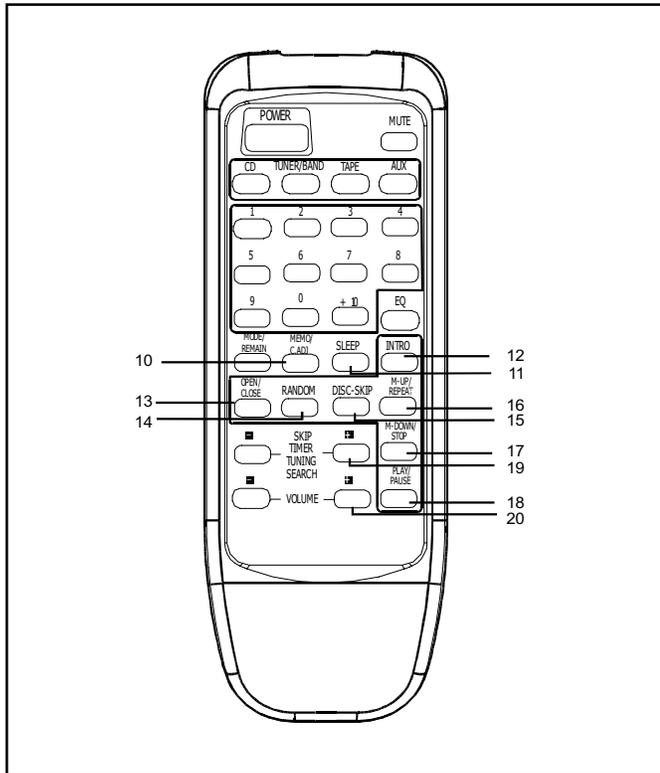

**NOTE:** The above **Time display** including: Clock display, Time ON, Time OFF.

### 10. MEMO / C-ADJ.

- In TUNER mode, press to store AM/FM stations in the memory locations.
- In CD mode, press to do CD program in memory locations.
- In clock adjust mode, press to set clock or timer adjustment.

### 11. SLEEP

Press to select the SLEEP timer on or off. Keep pressing this key will set the sleep time from 00 to 90 minutes.

### 12. INTRO

Press to set or release the intro scan play mode in CD mode.

### 13. OPEN / CLOSE

Press to open or close the CD door.

### 14. RANDOM

Press to toggle CD random play mode, the RANDOM

## REMOTE CONTROL

indicator appears on the display and tracks on all discs are played in random order. When the last track of the last disc is played, the system will automatically stop, unless you have selected REPEAT mode.

### 15. DISC SKIP

- In CD memory set mode, press to set to next valid disc number in ascending order.
- In CD normal play or stop mode, press to skip to next valid disc in ascending order.
- Not in CD mode, press to skip to next valid disc in ascending order when the door is open.

### 16. M-UP / REPEAT

- In CD mode, press to change the following repeat play mode cyclically: All disc, Repeat all disc, Repeat one disc, Repeat one track.
- In TUNER mode, press to call the preset memory in ascending order.

### 17. STOP / DOWN

- In CD mode, press to stop CD playing and exit CD memory registration mode. When CD is stop, press this key to clear CD memory.
- In TUNER mode, press to call the preset memory in descending order.

### 18. PLAY/PAUSE

Press to begin playback of the CD and press again to pause CD playback.

### 19. SKIP (-) or (+)

- In TUNER mode, press less than 0.5 second to do manual tuning.
- In TUNER mode, press longer than 0.5 second to do auto tuning.
- In CD mode, press less than 0.5 second to move track up or down.
- In CD mode, when CD is playing, press longer than 0.5 second to search up or down.
- In clock or timer adjusting enable state mode, press to adjust clock time.

### 20. VOLUME (-) or (+)

Press (+) or (-) button to adjust the sound level up or down.

## AMPLIFIER

### GENERAL

1. Press the POWER button to turn the system on.
2. Select the source by pressing the desired source selector button:
  - Press the TUNER button to listen a radio station.
  - Press the TAPE button for audio cassette.
  - Press the CD button to listen a compact disc.
  - Press the PHONO / AUX button to select phonograph function or for a laser disc player, camcorder or VCR, etc...
3. Press the VOLUME button on the front panel or on the remote control to adjust the volume level up or down.
4. Press the EQ button repeatedly to cyclic select a preset equalizer mode: ROCK , CLASSIC, POP or FLAT.

**NOTE:** *The Graphic Equalizer separates and adjusts the bass, midrange and treble levels. These preset selections adjust the sound to simulate and enhance the acoustical effects of ROCK, CLASSIC, POP or FLAT.*

5. Press the MUTE button to cancel the sound. The MUTE indicator will illuminate. Press again to return to original sound level.

## TIMER SETTING

### CLOCK SETTING

1. Turn the system on and press the MODE / REMAIN button until the clock appears in the display.
2. Press the MEMO / C-ADJ button once time, hour digit will flash and press the TUNING • DOWN / PREVIOUS or TUNING • UP / NEXT button until the correct hour digit appears.

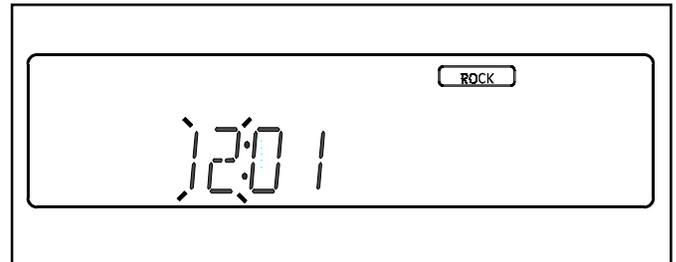

3. Press the MEMO / C-ADJ button again, minute digit will flash and press the TUNING • DOWN / PREVIOUS or TUNING • UP / NEXT button until the correct minute digit appears, and then press MEMO / C-ADJ button to confirm the setting.

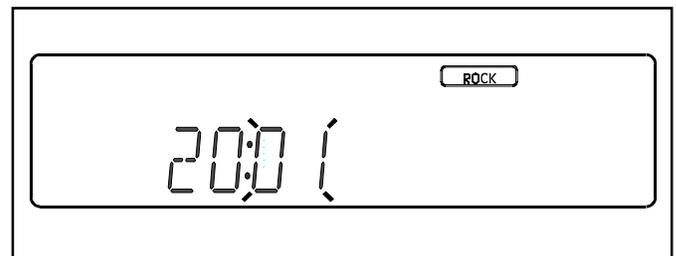

### TIME ON / OFF SETTING

Your music center can automatically turn itself on or off when the on or off time arrive.

#### TIME ON SETTING

1. Turn the system on and press the MODE / REMAIN button until the Time ON appears.

## TIMER SETTING

2. Press the MEMO / C-ADJ button once time, hour digit will flash and press the TUNING • DOWN / PREVIOUS or TUNING • UP / NEXT button until the correct hour digit appears.

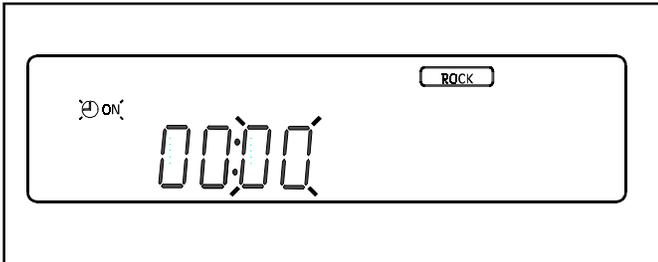

3. Press the MEMO / C-ADJ button again, minute digit will flash and press the TUNING • DOWN / PREVIOUS or TUNING • UP / NEXT button until the correct minute digit appears, and then press MEMO / C-ADJ button to confirm the setting.

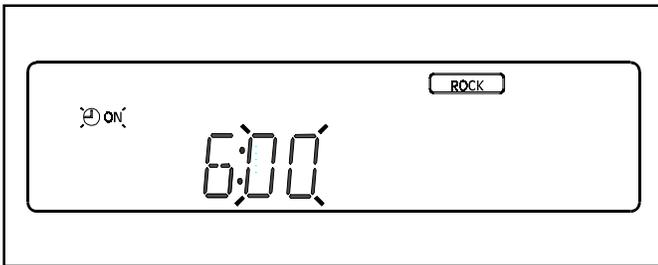

### TIME OFF SETTING

1. Press the MODE / REMAIN button until the Time OFF appears.
2. Press the MEMO / C-ADJ button once time, hour digit will flash and press the TUNING • DOWN / PREVIOUS or TUNING • UP / NEXT button until the correct hour digit appears.

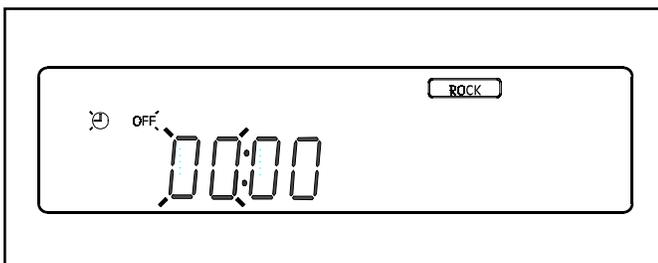

3. Press the MEMO / C-ADJ button again, minute digit will flash and press the TUNING • DOWN / PREVIOUS or TUNING • UP / NEXT button until the correct minute digit appears, and then press MEMO / C-ADJ button to confirm the setting.

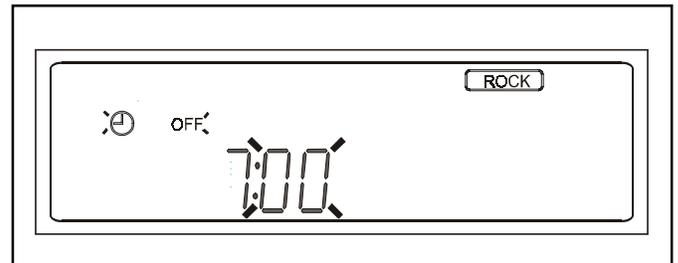

4. Press the TIMER button until the  appears, then press the POWER button to turn the system to STANDBY mode.

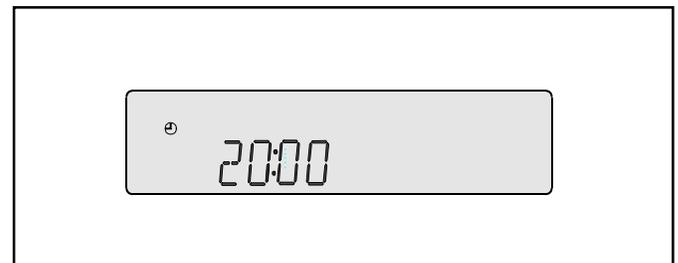

**NOTE:** Make sure the  is appearing, the system will automatically turn on/off itself when set time arrive.

### SLEEP TIMER

Your system can automatically turn itself off after 10 to 90 minutes. Choosing the period that you wish system to stay on, and when the "SLEEP" time arrives, the system will turn itself off automatically.

1. Turn the system on and press SLEEP button, the "SLEEP" indicator will illuminate.
2. Press the SLEEP button continuously to set the sleep time from 90 to 10.

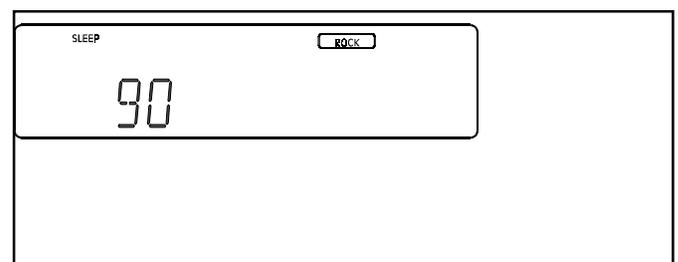

# TURNTABLE

## PHONO

### CONTROLS AND FEATURES

1. Turntable platter
2. Cueing lever
3. Speed selector
4. Tone arm
5. Tone arm rest
6. 45 rpm Adaptor

## PHONO

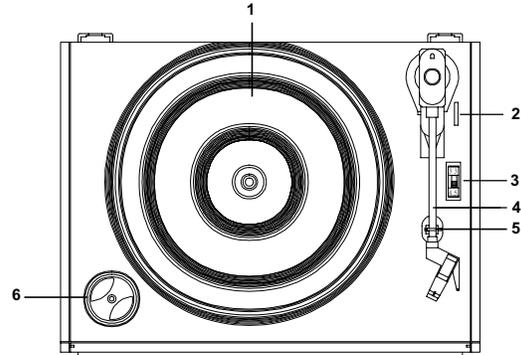

### PLAYING A RECORD:

1. Switch the system on using the POWER button.
2. Remove the stylus cover.
3. Unlock the tone arm using the tone arm lock.
4. Use the function selector to select the PHONO / AUX position.
5. Set the speed selector to either 33 rpm or 45 rpm according to the record to be played. Use the 45 rpm sprindle adaptor to play 45 rpm records which do not have a center.
6. Place a record on the turntable. Using the cueing lever, raise the tone arm. Move the tone arm outwards, away from the turntable platter. The turntable platter will start to rotate.
7. Move the tone arm over the record and release gently lower the Cueing Lever, The stylus will lower onto the record and start to play.
8. Adjust the VOLUME control to obtain the desired listening level.
9. Adjust the graphic equalizer to suit your listening pleasure.
10. During play (if you wish so) move the tone arm inwards towards the center of the turntable platter, thus switching it off. Ensure the tone arm is replaced and locked correctly using the tone arm lock. This will avoid damage to the stylus when the record deck is not in use.
11. When the record has finished playing, the turntable platter will switch off automatically. Secure tone arm using the tone arm lock.

**NOTE:** If you input signal from AUX jack while Phono is playing, you may hear both simultaneously.





## CD CHANGER

### LOADING A DISC INTO THE CD TRAY

1. Press the POWER button to switch on the system.
2. Select the CD function by pressing the CD button on the front panel. You can also press the CD button on the remote control.
3. The disc indicator corresponding to the currently selected disc will be surrounded by a illuminating semi-circle at all times.

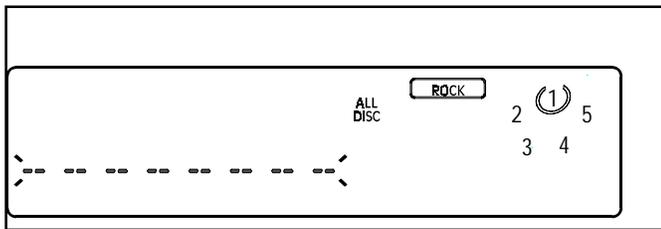

4. Press the OPEN / CLOSE button to open the CD door.
5. Insert only one disc into each of the five CD trays.
6. To insert a disc into the fifth tray, press the DISC SKIP or CD button and the fifth disc position will rotate to the front automatically.
7. Press the OPEN / CLOSE button again to close the CD door.

### DISC STATUS

To check the disc status, first press the PLAY / PAUSE button to start playback, then press the DISC SKIP button once for each disc.

1. When the particular disc tray is being checked by the playback sensor, the total tracks number and total time will be read and appeared.
2. If there is no disc in the selected tray, the disc number indicator light will go out.

### NORMAL CD PLAYBACK

1. Press the PLAY / PAUSE button to start playback. Press repeatedly to start or pause the CD playback.
2. The playback sensor will search the disc trays.
3. If the first disc tray is empty, the disc number indicator for that disc will disappear. Then the playback sensor will detect the next disc and the semi-circle indicator for the next disc will illuminate.

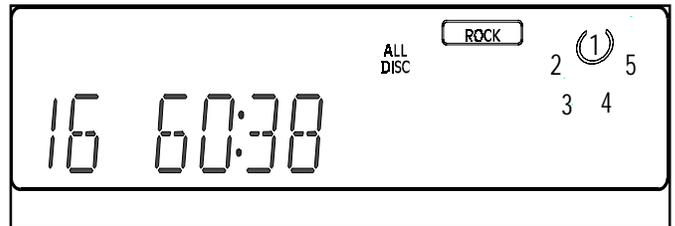

4. When the first disc is found, it will immediately begin to read and appear the total tracks number and total time of this disc. Press the PLAY / PAUSE button to begin to playback from track 1.
5. Press the TUNING • DOWN / PREVIOUS or TUNING • UP / NEXT button briefly to select the desired track.
6. Press and hold the TUNING • UP / NEXT button to move forward.
7. Press and hold the TUNING • DOWN / PREVIOUS button to move backward.
8. Press the STOP / MEMO • DOWN button to stop CD playback.
9. You can interrupt CD playback by pressing PLAY / PAUSE. Press the same key again to resume playback.
10. To select another disc, simply press the DISC SKIP or CD button repeatedly until the desired disc is selected.

## CD CHANGER

### CD RANDOM PLAYBACK

1. Press the RANDOM button before or during play.
2. The RANDOM indicator illuminates and tracks are now played in a random order.

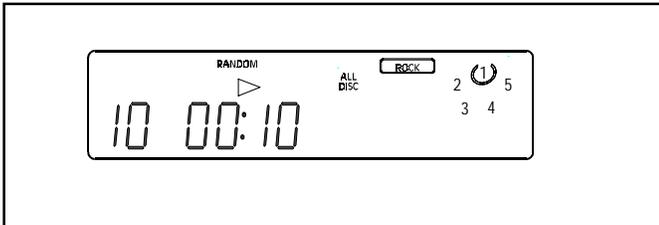

3. Each time you press the TUNING • UP / NEXT button to select the next random track.
4. Press the TUNING • DOWN / PREVIOUS button to return to the beginning of the track.
5. Press the RANDOM button again if you wish to return to normal play.

### CD REPEAT PLAYBACK

1. Press the REPEAT / MEMO • UP button once before or during playback to select the REPEAT ALL DISC mode, and the " REPEAT ALL DISC " indicator will illuminate. When this mode is selected, the tracks on all discs will be played repeatedly.

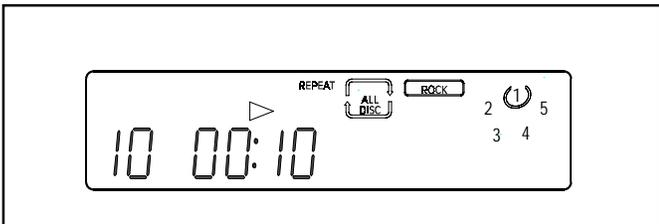

2. Press the REPEAT / MEMO • UP button twice before or during playback to select the REPEAT ONE DISC mode, and the " REPEAT ONE DISC " indicator will illuminate. When this mode is selected, all tracks on one particular disc will be played repeatedly.

### CD REPEAT PLAYBACK

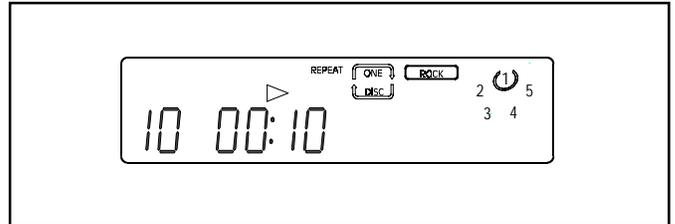

3. Press the REPEAT / MEMO • UP button three times before or during playback to select the REPEAT ONE mode. When this mode is selected, the same track will be played repeatedly.

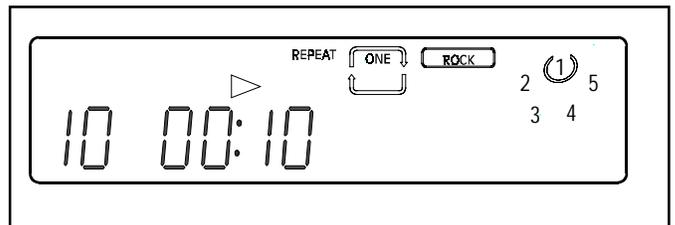

4. Press the REPEAT / MEMO • UP button four times to cancel the Repeat Playback function.

### DISPLAYING TIME INFORMATION

1. In CD normal play mode, press MODE / REMAIN button to change the following display cyclically:

•Playing time of current track.

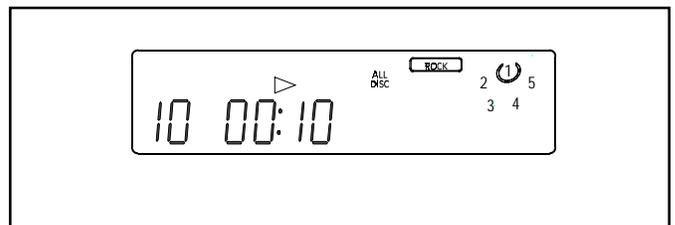

•Remaining time of current track.

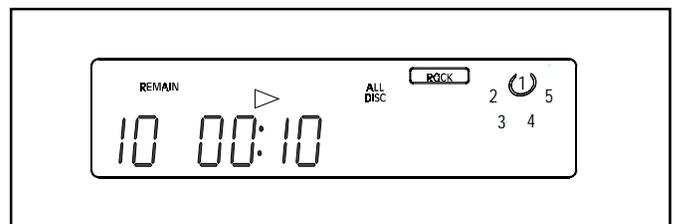

## CD CHANGER

- Total remaining time of current disc

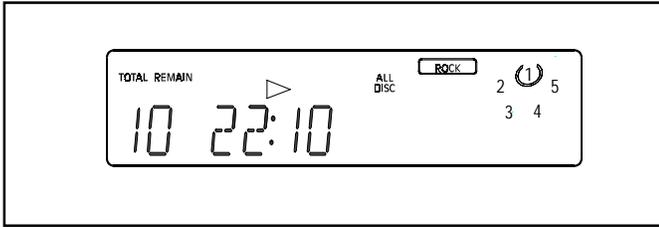

- Total playing time of current disc.

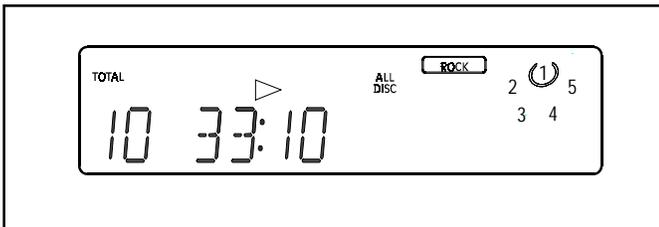

### CD PROGRAM ( CD MEMORY )

1. In CD stop mode, press the MEMO / C-ADJ button to select the program number appears on the display.
2. The track number, program number and "MEMORY" indicators will flash.

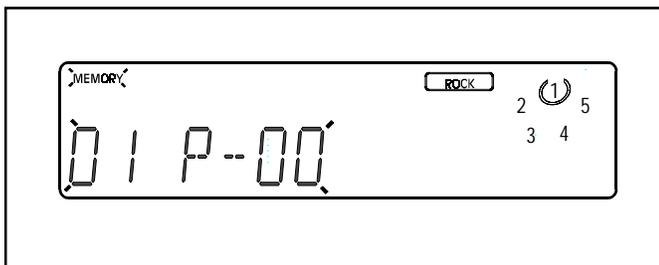

3. Select the number of disc by pressing the DISC SKIP button, and press the TUNING • UP / NEXT or TUNING • DOWN / PREVIOUS button until the desired track number that you wish to program appears on the display.

4. Press the MEMO / C-ADJ. button to store the track number you selected into the CD program, and the CD program number shows on LCD display.

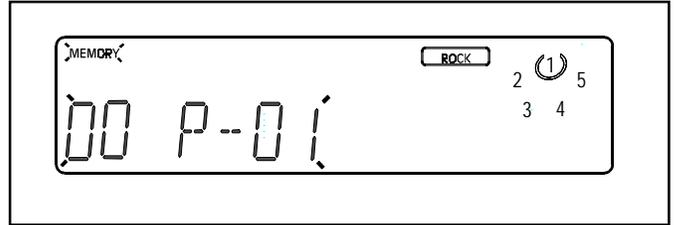

5. Select another track number and store the track into the CD program by above step 3 to step 4.

NOTE: Up to 40 CD tracks (00 ~ 39) can be programmed.

6. After the CD program has been done, press the PLAY / PAUSE button to start playing the programmed tracks.
7. In CD stop mode, Press MEMO/C-ADJ and then STOP / MEMO DN button on the front panel or remote control to erase program.

**NOTE:** When the CD program has been done, you can only play the memory tracks. Unless you erase the CD program, the CD normal playing can not be resumed to do.

## TAPE PLAYER

### LOADING ONE TAPE

1. Press the POWER button to switch on the system.
2. Select the TAPE function by pressing the TAPE button on the front panel or remote control.

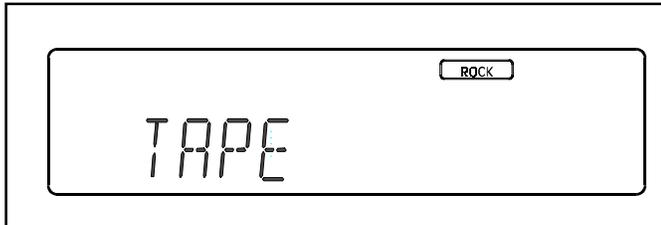

3. Depress the STOP / EJECT button of either [ DECK A ] or [ DECK B ] to open the door.
4. Insert only one tape into either [ DECK A ] or [ DECK B ].
5. To close the tape deck door, simply push the door back to its previous position.

### NORMAL PLAYBACK [ DECK A ] or [ DECK B ]

1. Press the PLAY button to start playback.
2. Depress the REW button to rewind the tape.
3. Depress the F.FWD button to start fast forward.
4. Depress the STOP / EJECT button to stop tape playback. Depress the STOP / EJECT button again to open the tape deck door.
5. You can interrupt tape playback by pressing the PAUSE button. Press the same button again to resume playback.

### RECORDING [ DECK A ]

#### Recording from TAPE to TAPE

1. Insert a blank tape into [ DECK A ].
2. Insert the tape to be copied into [ DECK B ].
3. Press the PAUSE button on [ DECK A ], then press the RECORD button. Press the PLAY button on [ DECK B ] to begin dubbing.
4. If you wish to double the recording speed, simply depress the ■ ST. / NOR & ■ MONO. / H.S.D. button to HSD mode before starting.

**NOTE:** When the HSD (High Speed Dubbing) function is activated, the playback speed of [ DECK B ] will also double.

5. To cancel the HSD function, press the ■ ST. / NOR & ■ MONO. / H.S.D. button again.
6. To stop or pause the recording, press the STOP / EJECT or PAUSE button on [ DECK A ].
7. To stop or pause playback, press the STOP / EJ or PAUSE button on [ DECK B ].

#### Recording from CD to TAPE

1. Insert a blank tape into [ DECK A ].
2. Select CD function by pressing the CD button on the front panel or remote control.
3. Insert the CD disc which is to be copied to the blank tape in [ DECK A ].
4. Press the RECORD and PLAY buttons on [ DECK A ] to start the CD-to-TAPE synchro recording. The "REC CD SYNC" indicator will illuminate on the LCD and the CD will start at the same time.

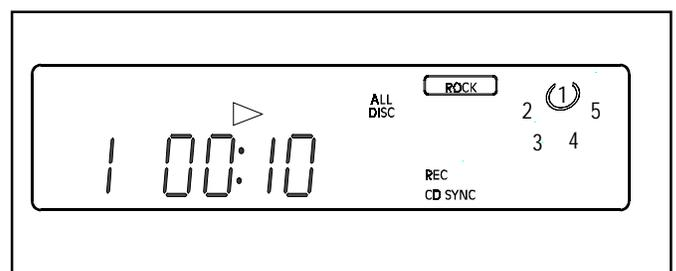

## TAPE PLAYER

### RECORDING [ DECK A ]

**NOTE:** To set up a CD program before recording, see page 17.

5. To stop recording, press the STOP / EJECT button on [ DECK A ], and at this time, the CD playback will be in the Pause mode, if you press the RECORD and PLAY buttons on [ DECK A ] again, the CD playback will continue playing automatically.
6. To stop or pause of CD playback, press STOP button or PLAY / PAUSE button of CD controls.

### Recording from TUNER to TAPE

1. Insert a blank tape into [ DECK A ].
2. Select the TUNER function by pressing the TUNER / BAND button on the front panel or remote control.
3. Press the TUNER / BAND button repeatedly until the desired band (FM or AM) is selected.
4. Press the TUNING • UP / NEXT or TUNING • DOWN / PREVIOUS button to select the desired frequency.
5. Press the RECORD and PLAY button on [ DECK A ] to start TUNER-to-TAPE recording.
6. To stop or pause recording, press the STOP/EJ or PAUSE button on [ DECK A ].

**NOTE:** The HSD function does not operate during CD-to-TAPE or TUNER-to-TAPE recording.

### SEQUENTIAL PLAYBACK [ DECK B ] TO [ DECK A ]

**NOTE:** The sequential play feature automatically plays [ DECK A ] after [ DECK B ] has played and shut off.

1. Insert a tape into [ DECK A ] and [ DECK B ].
2. Press the PLAY button on [ DECK B ] to begin playback.
3. Press the PAUSE button on [ DECK A ].
4. Press the PLAY button on [ DECK A ]. When the tape in [ DECK B ] reaches the end, the PAUSE button on [ DECK A ] will release automatically and playback will begin.

# TUNER

## AUTO ( automatic ) / MANUAL TUNING

1. Press the POWER button to switch on the system. Select the TUNER function by pressing the TUNER / BAND button on the front panel or remote control.
2. Press the TUNER / BAND button repeatedly until the desired band (FM or AM) is selected.
3. For manual tuning, quickly press and release the TUNING • DOWN / PREVIOUS or TUNING • UP / NEXT button to select the desired frequency.
4. For auto tuning, press and hold the TUNING • DOWN / PREVIOUS or TUNING • UP / NEXT button for 1 second. The system will search until a station of sufficient strength is found. If the station is not the desired one, simply press and hold the TUNING • DOWN / PREVIOUS or TUNING • UP / NEXT button for 1 second again. Weak stations are skipped during automatic tuning.

**NOTE:** When tuning, the sound will be muted to eliminate interfering background noises. When a station is found, the audio signal will come back on. "STEREO" will appear on the display when an FM-stereo signal is received. With weak FM stereo signals, you may hear static or background noise. These noises can be suppressed by switching to MONO. Simply press the  ST./NOR. &  MONO /H.S.D. button to select MONO mode. "STEREO" will disappear from the LCD.

## PRESET MEMORY

### Storing preset stations

You can store preferred stations in the TUNER's memory (Each 20 stations for FM and AM).

1. Press TUNER / BAND button to select TUNER function and FM or AM band.
2. Press the TUNING • DOWN / PREVIOUS or TUNING • UP / NEXT button to select the frequency you wish to memorize.
3. Press MEMO / C-ADJ button, the "Memory" indicator will flash, then press REPEAT / MEMO • UP or STOP / MEMO • DOWN to select the desired location preset is reached.
4. Press MEMO / C-ADJ button again to store the station into the designated location. If you have missed carelessly pressing the button to store it, the system will memory automatically after 5 seconds.

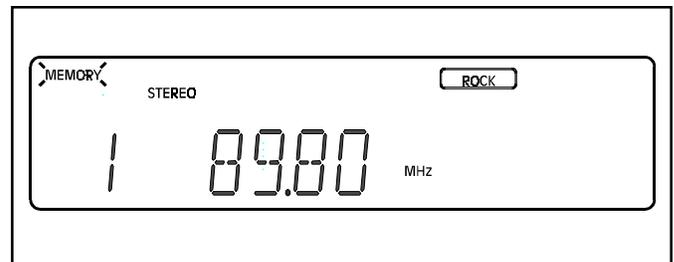

5. Used remote control, press MEMO / C-ADJ button, the "Memory" indicator will flash, then press 0 ~ 9/+10 button to select the desired location, and system will memory automatically.
6. To set another preset station, follow steps 2 to 4.

### Selecting preset stations

1. Select the TUNER function and FM or AM band with the TUNER / BAND button on the front panel or remote control.
2. Press the REPEAT / MEMO • UP or STOP / MEMO • DN button on the front panel or remote control until the required preset memory number appears. Or press the 0-9/+10 digit buttons on the remote control to select the preset stations directly.

## GENERAL INFORMATION

### TROUBLESHOOTING

Please make these simple checks before calling for service. These tips can save you time and money.

- |                             |                                                                                                                                                                                                                                                                                                                                                                                                                                                                                                         |
|-----------------------------|---------------------------------------------------------------------------------------------------------------------------------------------------------------------------------------------------------------------------------------------------------------------------------------------------------------------------------------------------------------------------------------------------------------------------------------------------------------------------------------------------------|
| NO POWER                    | <ul style="list-style-type: none"><li>• Make sure the power cord is inserted fully into a 120V/60Hz outlet.</li><li>• Check to be sure that the outlet is not controlled by a wall switch.</li></ul>                                                                                                                                                                                                                                                                                                    |
| NO VOLUME                   | <ul style="list-style-type: none"><li>• Unplug the power cord, wait 1 minute, then reinsert the plug and push the <b>POWER</b> button.</li><li>• Check the VOLUME control setting.</li><li>• Make sure the correct feature has been selected ( for instance, " CD " should be selected when playing a CD ).</li><li>• Make sure the speakers are properly connected.</li><li>• Make sure the speaker wires are not shorted together.</li><li>• If headphones are plugged in, disconnect them.</li></ul> |
| REMOTE CONTROL DOESN'T WORK | <ul style="list-style-type: none"><li>• Check and if necessary, replace the batteries.</li><li>• Make sure the remote is pointed head-first at the Music Center.</li><li>• Make sure the Music Center is plugged into an operating wall outlet.</li><li>• The remote may be too far away from Music Center.</li></ul>                                                                                                                                                                                   |
| CAN'T TUNE RADIO STATIONS   | <ul style="list-style-type: none"><li>• Repeat channel selection.</li><li>• Make sure the antennas are properly connected.</li></ul>                                                                                                                                                                                                                                                                                                                                                                    |

**NOTE:** *if the operation of the unit or display is not normal, you should reset the unit by disconnecting it from the household wall outlet for 1 minute and then reinsert the plug.*

**WARNING:** IF YOU ARE UNABLE TO REMEDY A PROBLEM BY FOLLOWING THESE HINTS, CONSULT YOUR DEALER OR AN AUTHORIZED SERVICE CENTER. UNDER NO CIRCUMSTANCES SHOULD YOU TRY TO REPAIR THE SYSTEM YOURSELF, AS THIS WILL INVALIDATE YOUR WARRANTY.

**CUSTOMER SERVICE : 1 - 800 - 919 - 3647**

# GENERAL INFORMATION

## SYSTEM SPECIFICATIONS

### RECEIVER

#### Power output:

Front ..... 10Wx2

Total harmonic distortion ..... 10%

Power supply ..... 120V/60Hz

#### Tuning Range:

FM ..... 87.5~108.0MHz

AM ..... 530~1710KHz

\*Specifications subject to change without notice.





**LIMITED WARRANTY  
AUDIO/PHONES**

We at MEMOREX believe you will be pleased with your new Product. Please read this Warranty carefully. Memorex warrants this product to be free from manufacturing defects including original parts and workmanship for a period of ninety(90) days from the date of original purchase in, and if used in, the United States.

Should you find your unit is not operating properly during the terms of full coverage of this warranty, ninety(90) days, you should contact your original place of purchase for an exchange with a valid receipt. If necessary, Memorex will provide one of the following options (at Memorex s discretion), providing the manufacturing defect is Verified along with the date of purchase.

- Repair service for ninety (90) days from date of original purchase at no charge for labor and parts at their authorized warranty service facillity, providing the manufacturing defect is verified along with the date of purchase.
- Replacement of defective unit with either a new, refurbished, or equivalent model at no charge for ninety (90) days from date of original purchase.

This warranty is void if the product is:

- A) Damaged through negligence, abuse, misuse, accident or acts of God.
- B) Used in commercial applications or rentals.
- C) Modified or repaired by anyone other than Memorex or their expressly authorized representative.
- D) Damage resulting from the improper connection to equipment of other manufacturers.

This warranty does not cover:

- A) Cost incurred in the shipping of the product to and from the Memorex authorized repair facility listed.
- B) Damage or improper operation caused by the failure to follow the operating instructions provided with the product.
- C) Routine adjustments to the product, which can be performed by the customer as outlined in the owner s manual.
- D) Signal reception problems caused by external factors.
- E) Products not purchased in the United States.
- F) Damage to the products used outside the United States.
- G) Damage to audiocassette tapes.
- H) Damage to Compact Discs.

In the event that service is required under this warranty, please contact CUSTOMER SERVICE at 1-800-919-3647 or contact our website at [www.memorex.com](http://www.memorex.com).

**THIS WARRANTY IS NON-TRANSFERABLE AND APPLIES SOLELY TO THE ORIGINAL PURCHASER AND DOES NOT EXTEND TO SUBSEQUENT OWNERS OF THE PRODUCT. ANY APPLICABLE IMPLIED WARRANTIES, INCLUDING THE WARRANTY OF MERCHANTABILITY, ARE LIMITED IN DURATION TO A PERIOD OF THE EXPRESSED WARRANTY AS PROVIDED HEREIN BEGINNING WITH THE DATE OF THE ORIGINAL PURCHASE AT RETAIL AND NO WARRANTIES, WHETHER EXPRESSED OR IMPLIED SHALL APPLY TO THE PRODUCT THEREAFTER , MEMOREX MAKES NO WARRANTY AS TO THE FITNESS OF THE PRODUCT FOR ANY PARTICULAR PURPOSE OR USE.**

**THE EXTENT OF MEMOREX S LIABILITY UNDER THIS LIMITED WARRANTY IS THE REPAIR OR REPLACEMENT PROVIDED ABOVE AT THE SOLE DISCRETION OF MEMOREX. IN NO EVENT SHALL MEMOREX S LIABILITY EXCEED THE PURCHASE PRICE PAID BY THE PURCHASER. UNDER NO CIRCUMSTANCES SHALL MEMCORP BE LIABLE FOR ANY LOSS, DIRECT, INDIRECT, INCIDENTAL, FORESEEN, UNFORESEEN, SPECIAL, OR CONSEQUENTIAL DAMAGE ARISING OUT OF OR IN CONNECTION WITH THE USE OF THIS PRODUCT.**

**THIS WARRANTY IS VALID ONLY IN THE UNITED STATES. THIS WARRANTY GIVES YOU SPECIFIC LEGAL RIGHTS, HOWEVER, YOU MAY HAVE OTHER RIGHTS WHICH MAY VARY FROM STATE TO STATE. SOME STATES DO NOT ALLOW LIMITATIONS ON IMPLIED WARRANTIES OR EXCLUSION OF CONSEQUENTIAL DAMAGE, THEREFORE THESE RESTRICTIONS MAY NOT APPLY TO YOU.**

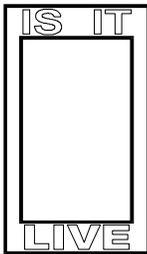

Memcorp, Inc.  
Hialeah, FL 33014  
© 1999 Memorex is a registered trademark of Memorex Telex M.V.  
Printed in Hong Kong

Visit our website at [www.memorex.com](http://www.memorex.com)