

Hotpoint Service and Spares

FOR SERVICE: If you have a problem with your appliance ring your local Service Office.
 FOR SPARES and ACCESSORIES: To purchase spares and accessories send your Accessories Order Form to your Spares Centre. If the accessory or spare part you want is not on the form, contact your Spares Centre for prices and availability.
 Please address all correspondence to Hotpoint Spares Centre or Hotpoint Service Office as applicable.

Service Offices and Spares Centres are open between 8.00am-5.00pm Monday to Friday, except on Public Holidays. 8.30am-12.30pm on Saturdays.

EAST

Industrial Buildings, Beehive Lane, Chelmsford, CM2 9TE.
 Post Codes RM & IG Tel: (0245) 492433
 Remainder of Essex Tel: (0245) 265331

Calla Road, PE2 9UB. Tel: (0733) 64741

Spares Administration Dept. Tel: (0733) 566520

LONDON

66 East Lane, HA9 7PQ. Tel: 081-904 4399

S. Herts and Middlesex Tel: 081-908 4722

Post Codes N, NW, E, EC Tel: 081-908 2511

Post Codes W, WC, SE, SW Tel: 081-908 2511

Tel: 081-904 0201

MIDLANDS

Westgate, Aldridge, W Midlands, WS9 8UX.
 Post Codes B Tel: (0922) 743374

All other Post Codes Tel: (0922) 743376

Tel: (0922) 743377

Asling Street, NG2 3UB. Tel: (0602) 860987

For Spares Tel: (0602) 860987

West Ave, Nelson Estate, Talka, S17 1TN. Tel: (0782) 774511

8 Beale House, Tower Road, Glover Est, District 11, NE37 2SH.
 Tel: 091-417-3500/419 3535

Sandbeck Lane, LS22 4TW.
 Tel: (0537) 58126/581444 For Spares Tel: (0537) 581221

NORTH WEST

Mumford House, 26 Highgate, LA9 4SX. Tel: (0539) 724483

44/46 Station Road, Heaton Mersey, Stockport, SK4 3DT.
 Manchester North Tel: 061-432 0515

Manchester South Tel: 061-442 8677

Tel: 061-432 0255

7 Bridle Way, Merseyside. Tel: 051-525 2342/524 2339

SCOTLAND

Holbeck House, 66 Cadden Place, AB1 1UL. Tel: (0224) 642283

35 West Bowling Green Street, Leith, EH6 5NX. Tel: 031-554 1431

West Lodge Road, Blythswood Estate, PA4 9EN.
 For Spares Tel: 041-886 6241

SOUTH

Larkfield Trading Est, New Hythe Lane, Larkfield, ME20 6SW.
 CT, DA, ME & TN Kent Post Codes Tel: (0622) 716571

CR, KT, RH, SM Surrey & BR Kent Post Codes (0622) 790707

GU Post Codes in Surrey Tel Southampton (0703) 667374

Tel: (0622) 716631

Unit R, S Hampshire Ind Park, Salisbury Rd, Totton, SO40 3SA.
 Tel: (0703) 861981/867374 For Spares Tel: (0703) 867933

1 Kingswood, North St, Halesham, BN27 1DQ. Tel: (0323) 842753

69 Mulvey Plain, PL4 6JH. Tel: (0752) 262631

WALES

Conwy Rd, Llandudno Junction, LL31 9RE. Tel: (0492) 573536

18 Western Ave, Bridgend Ind Estate, Bridgend, CF31 3SL.
 Post Codes CF, SA, & SY28-25 Tel: (0656) 664121

Post Codes BS, GL, (not 55), HR, SY15-18, LD1-8, NP. Tel: (0656) 665564

Tel: (0656) 786111

IRELAND

● **NORTHERN:**

256 Ormeau Road,
 Belfast, BT7 2TZ

Tel: (0232) 647111

49 Airways Ind. Estate,
 Dublin 17.

Tel: Dublin 426088

Tel: Dublin 426836

For Service

For Spares

CHANNEL ISLANDS

Normal Guarantees apply and all Service Schemes are available.

JERSEY:

19 Don Street, St. Helier.
 Tel: (0534) 21625

or

Clos D'Ormes, Pontiac,
 St Clements. Tel: (0534) 54808

GUERNSEY & SARK:

Valpys Stores, Grande Rue, St Martins,
 Guernsey. Tel: (0481) 39422

or

Barras Lane, Vale,
 Tel: (0481) 51610

32 High Street,
 Tel: (0481) 822886

ALDERNEY:

ISLE OF MAN

Normal Guarantees apply and all Service Schemes are available

from

5 Drumgold St., Douglas.
 Tel: (0624) 672333

or

Tromode Works,
 Cronkbourne Village, Douglas,
 Tel: (0624) 676066

or

17 Ridgeway Street, Douglas,
 Tel: (0624) 258117/25948

SHETLAND, ORKNEY & WESTERN ISLES

Service provided by Agents. Normal Guarantees apply, but Service Schemes are NOT available.

SHETLAND:

For Road, Lerwick.
 Tel: (0595) 2557

Hairstone Ind. Estate, Kirkwall.
 Tel: (0856) 5457

ORKNEYS:

27 Bayhead Street,
 Stromway, Isle of Lewis
 Tel: (0851) 3387

WESTERN ISLES:

Local Hydro Electric Shops.

OTHER ISLANDS:

EXCEPT ARRAN,
 BUTE & SKYE—

Which are covered by Hotpoint.

- Service Office and Spares Centre
- Service Office only

HOTPOINT HANDBOOK

INTEGRATED LARDER FRIDGE

MODEL 6936

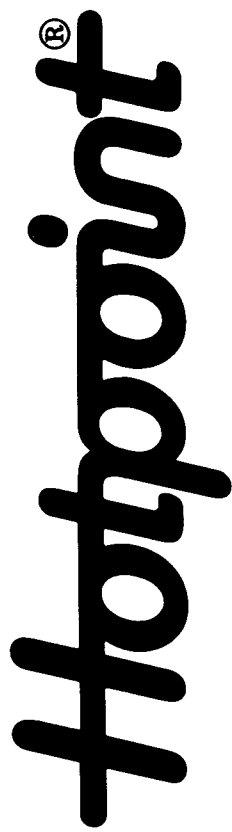

In accordance with its policy of progressive product design, the Company reserves the right to alter specifications.
 Hotpoint Ltd, Peterborough, PE2 9UB, England

Your new Hotpoint Integrated Larder Fridge

Using your new Larder Fridge is very simple. Nevertheless, to get the best results it is important that you read right through this handbook **before** using your Larder Fridge for the first time.

Electrical Requirements

We recommend that this appliance is connected to the mains supply via a suitable switched socket in a readily accessible position.

All Hotpoint appliances come complete with a fitted plug. The plug on your fridge has a 13A fuse. If the plug does not fit your sockets, a new plug can be fitted. Cut off the old plug and throw it away, do not insert it into a socket elsewhere in the house as this could cause a shock hazard.

WARNING: THIS APPLIANCE MUST BE EARTHED.

IMPORTANT: Fitting a Different Plug:

The wires in the mains lead are coloured in accordance with the following code:

- Green and Yellow — Earth
- Blue — Neutral
- Brown — Live

If you fit your own plug the colours of these wires may not correspond with the identifying marks on the plug terminals. This is what you have to do:

1. Connect the green and yellow (Earth) wire to the terminal in the plug marked 'E' or with the symbol , or coloured green or yellow.
2. Connect the blue (Neutral) wire to the terminal in the plug marked 'N' or coloured black.
3. Connect the brown (Live) wire to the terminal marked 'L' or coloured red.

With alternative plugs a 5A fuse must be fitted either in the plug or adaptor or in the main fuse box. In the event of replacing a fuse in the plug supplied, a 13A ASTA approved fuse to BS1362 must be fitted.

If the plug is the moulded on type the fuse cover must be refitted when changing the fuse. In the event of losing the fuse cover the plug must **not** be used until a replacement fuse cover has been obtained and fitted. A new fuse cover can be obtained from your nearest Hotpoint Spares Centre or local Electricity Company. The colour of the correct replacement fuse cover is that of the coloured marks or insert in the base of the plug.

Mains Lead Replacement

If the mains lead on this appliance needs replacing at any time, it must be replaced by a lead which is obtainable from your nearest Hotpoint Service Office (see back page). A charge will be made for the replacement of the mains lead if you have damaged the lead or require a longer lead.

WARNING: AVOID ACCIDENTS TO CHILDREN. WHEN DISCARDING AN OLD FRIDGE OR FREEZER BE CERTAIN TO MAKE THE LOCK UNUSABLE. IF POSSIBLE REMOVE THE DOORS AND DISCARD SEPARATELY. DO NOT ATTEMPT TO STAND OR SIT ON TOP OF YOUR APPLIANCE. IT IS NOT DESIGNED FOR SUCH USE AND YOU COULD INJURE YOURSELF OR DAMAGE THE APPLIANCE BY SUCH ABUSE.

Hotpoint Service Cover

Satisfaction Guaranteed or Your Money Back

Hotpoint gives you a unique 'Satisfaction Guaranteed' promise – valid for ninety days after you have purchased your Hotpoint product. If there is a problem with your Hotpoint appliance just call your Hotpoint Service Office. If necessary we will arrange for an engineer to call. If the problem is not resolved by us under this Guarantee, Hotpoint will replace your appliance or, if you prefer, give you your money back. This Guarantee is additional and subject to the terms of Hotpoint's Five Year Parts Guarantee.

Hotpoint's Free Five Year Guarantee

From the moment your appliance is delivered, Hotpoint guarantees it for **FIVE YEARS**.

- In the Five Years all replacement parts are **FREE** provided they are fitted by our own Service Engineer. During the first year our Engineer's time and labour is also free.
- After the first year we will charge for our Engineer's time and labour. We do, however, operate a range of Service Plans (see opposite) which for an annual payment enables you to cover any repair costs which may be necessary
- All of our service repairs are guaranteed for twelve months in respect of our labour and any parts fitted.
- The appliance must be used in the United Kingdom and must not be tampered with or taken apart by anyone other than our own Service Engineer.
- You may, however, buy parts which can be safely fitted without specialist knowledge or equipment. The correct fitting of such parts, provided they are genuine Hotpoint spares, will not affect your Guarantee. Parts are available from our main Hotpoint Spares Centres.
- Our Guarantee does not cover the cost of any repair which is needed because of power cuts, accidents or misuse. Nor does it cover the cost of any visit to advise you on the use of the appliance except for our Free Installation Check for Automatic Washing Machines and Dishwashers. Please read the instruction book thoroughly.
- If at any time during the Guarantee period we are unable to repair your appliance, we will refund any repair costs paid to us in the previous twelve months. We will also offer you a new appliance at a reduced charge instead of a repair.
- Our Guarantee is in addition to and does not affect your legal rights.
- Should you need independent advice on your consumer rights, help is available from your Consumer Advice Centre, Law Centre, Trading Standards Department and Citizens Advice Bureau.

- All Hotpoint servicing is done by our own Service Organisation located throughout the United Kingdom and Southern Ireland. It will be happy to deal with any problems.

Hotpoint's Service Care

Whether you have just one or a number of Hotpoint appliances in your kitchen, Hotpoint has a range of Service Schemes to give you complete peace of mind.

Service Cover

A single payment covers you for all repairs during the period of cover, which can be from 1 to 4 years. There is also an option of Service Cover with Maintenance at an additional cost. This includes an annual Electrical and Safety check and replacement of any parts as necessary. For 1 year contracts this takes place towards the end of the contract period.

Kitchen Cover

An annual payment covers you for all repairs for all your Hotpoint appliances which are less than 10 years old. It also covers the cost of loss of food up to £250 in our refrigeration and freezer products. There is also the option of Kitchen Cover with Maintenance at an additional cost. Any additional Hotpoint appliances purchased after you have joined Hotpoint Kitchen Cover will automatically be included during the annual period of cover without further charge.

Appliance Registration

To ensure that you have the opportunity to benefit from any of the above Service Schemes you should complete and return immediately the Appliance Registration Form supplied with your appliance. Full details and costs of our Service Schemes together with an application form will be sent to you at the end of the first year of the guarantee.

Annual Safety/Maintenance Checks

Hotpoint strongly recommends that all its appliances are regularly checked for electrical and mechanical safety whether or not they are covered by a Service Plan.

Proof of Purchase

For future reference please attach your purchase receipt to this booklet and keep it in a safe place.

Spares and Accessories

Spares and accessories can be ordered from your local Hotpoint Spares Centre (listed on the back page), using the order form enclosed.

NOTE: Our Engineer will use every effort to avoid damage to floor coverings and adjacent units when carrying out repairs/service work but in locations where the Engineer advises you that it will be impossible to move the appliance without risk of damage, he will only proceed with your approval that no liability is accepted.

Caring for your Fridge (cont.)

Replace the plug in the power point and switch on.

NOTE: The interior light will not work when the thermostat control is set in the OFF position ie 'O'.

If your Integrated Larder Fridge won't work

... don't panic
Just run through these quick checks before calling your nearest Hotpoint Service Office.

1. Check that the plug is firmly in the wall socket and that the power supply is on.
2. Check the power supply to the socket by plugging in another appliance.
3. If the other appliance works, check the fuse in the Larder Fridge's plug.
4. If you have changed the plug, check the wiring (see page 2).
5. If there is excessive noise or vibration, check that all four feet are firmly in contact with the ground (see page 7).
6. If the interior light fails to work, refer to page 13 for further instructions.
7. If water appears on the inside floor or under the Salad Bins, check that the gutter drain hole has not become blocked, and that there is nothing touching the back wall. If blocked, the drain hole may be cleared by pushing the end of a pipe cleaner or straw through the drain hole and gently moving it up and down. (NB Water droplets on the cooling plate or back wall are normal.)

If, after following all these instructions, you are still having problems, contact your nearest

If the light still fails to work, do not worry, it will not affect the working of your Larder Fridge. Obtain a replacement SES 15 Watt bulb from your nearest Hotpoint Spares Centre and replace old bulb.

Hotpoint Service Office (or local importer if outside the United Kingdom). The telephone number is shown on the back page.

When you contact us we need to know:

1. Your name, address and post code.
 2. Your telephone number.
 3. Clear and concise details of the fault.
 4. The model number 6936, and colour.
 5. When it was purchased. Please put the date here
 6. If you have subscribed to the Hotpoint Service Cover Plan (see opposite page).
- Make sure you have all these details before you call.

Contents

	Page
Installing your Integrated Larder Fridge	4
Positioning your Integrated Larder Fridge	4
Dimensional requirements	4
Fittings supplied	5
Repositioning the door hinge	5
Fitting a decor door to match your kitchen units	6
Adjusting the plinth depth	7
Adjusting the decor door	8
Get to know your Integrated Larder Fridge	9
Getting your Integrated Larder Fridge ready for use	10
Starting and running in	10
Controlling the temperature	10
Storing food	11
Do's and Don'ts	12
Caring for your Integrated Larder Fridge	13
No defrosting	13
Cleaning	13
Going away	13
Replacing the Interior Light	13-14
If your Larder Fridge won't work	14
Hotpoint Service Cover Plan	15
Hotpoint Service Offices	Back page

Retention of this Instruction Book

This Instruction Book must be kept handy for reference as it contains important details on the safe and proper use of the appliance.

If you sell or pass the appliance to someone else, or move house and leave it behind, make sure this Book is also provided so the new owner can become familiar with the appliance and safety warnings.

If the Book is lost or damaged a copy may be obtained from Hotpoint Ltd, Celta Road, Peterborough, PE2 9JB.

Installing your Integrated Larder Fridge

Before fitting:

1. Please read completely through this section before starting any work.
2. If possible install the appliance before the unit worktop is fitted as this makes the work easier.

Positioning your Integrated Larder Fridge

Your Integrated Larder Fridge should be fitted into a cupboard unit space under a work surface, where it is easy to use. The power socket should be in a readily accessible position adjacent to the unit. Avoid putting the Larder Fridge near anything which gives off heat, a cooker or radiator for example. In such a position your Larder Fridge will have to work harder and will cost more to run. If the Larder Fridge is to be installed side by side with the Integrated Freezer (Model 6956) always position the Larder Fridge to the left of the Freezer (viewed from the front). The heater located in the left side panel of the Integrated Freezer prevents condensation from forming between the two appliances.

Dimensional requirements

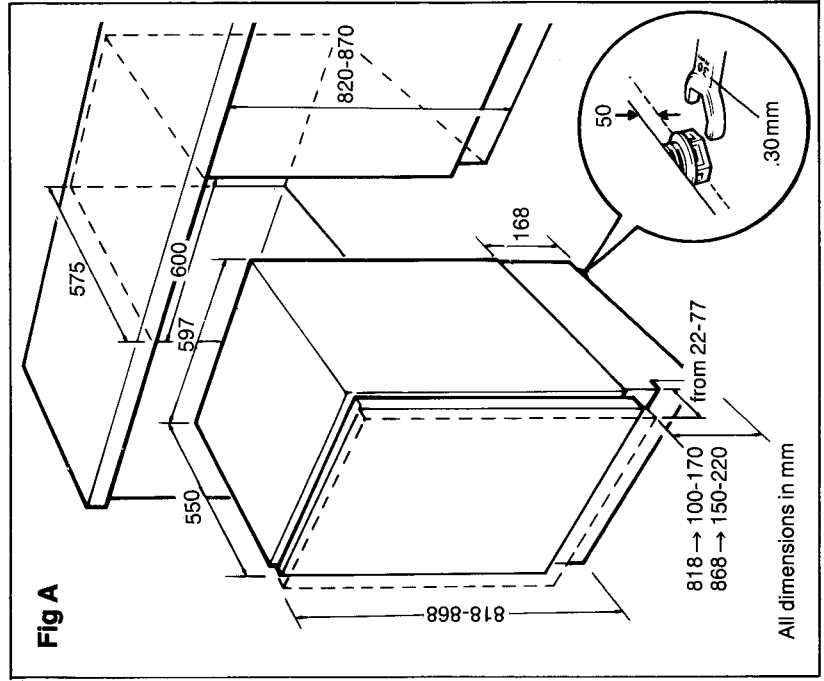

Caring for your Integrated Larder Fridge

No defrosting

Your Larder Fridge will defrost itself automatically when the compressor is not running. During defrosting water droplets will run down the back wall to the interior gutter, and drain out through the hole into a special container where the water evaporates. Some droplets may remain on the back wall and re-freeze when defrosting is complete. If your kitchen becomes exceptionally warm the Fridge may not defrost regularly. Do not worry. Periodic defrosting will begin again when conditions return to normal. Do make sure that the interior gutter is always kept clear and that stored food does not come into contact with the back wall (**Fig M**).

Cleaning your Integrated Larder Fridge

It is a good idea to clean the inside of your Larder Fridge regularly. **Always switch off at the mains plug outlet and pull out the mains plug first.** Remove any food. Wipe out the inside of the Larder Fridge using a clean cloth wrung out in either a solution of one teaspoonful of bicarbonate of soda to one pint of water or Milton diluted according to the manufacturer's instructions. The complete interior including the door, and removable parts, should be washed with care ensuring that the cloth does not become caught on any part of the appliance. **Never** use any household cleaner or detergent, abrasive powders or wax polish. These not only damage the surfaces, but also leave a smell in the Larder Fridge. Make sure that no particles of food are left in the interior gutter. If the drain hole becomes blocked it

may be cleared by pushing the end of a pipe cleaner or drinking straw through the drain hole and gently moving it up and down.

The rubber door seal must be cleaned with soap and water only as detergent will damage it.

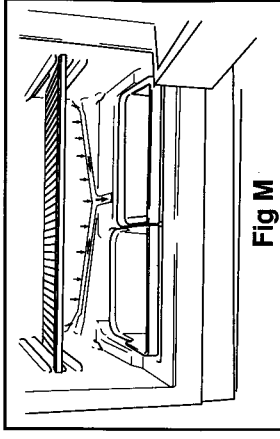

Going away

If you expect to be away for any length of time and don't want to use your Integrated Larder Fridge, switch off at the power point and pull out the plug. Remove all food and wipe out the interior. **Always** leave the door ajar to prevent the accumulation of odours.

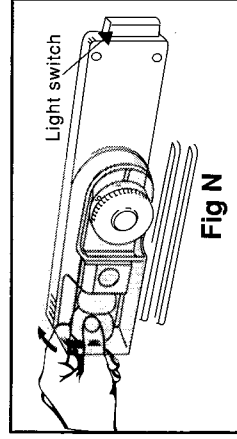

How to replace the interior light

Should the light fail to work, switch off at the power point and pull out the plug. Remove the shelves to make access easier. Access to the bulb is from the rear of the cover, see Fig N. Unscrew the old bulb. Screw the new bulb securely into the holder.

Do's and Don'ts

DO

- Do:--** Take off any unusable leaves on vegetables and wipe off any soil.
- Do:--** Leave lettuce, cabbage, parsley and cauliflower on the stem.
- Do:--** Wrap cheese firstly in greaseproof paper and then in a polythene bag excluding as much air as possible. For best results take out of the fridge an hour before eating.
- Do:--** Wrap raw meat and poultry loosely in polythene or aluminium foil. This prevents drying.
- Do:--** Wrap fish and offal in polythene bags.
- Do:--** Wrap foods which have a strong odour or can dry out in polythene bags, aluminium foil or place in airtight containers.
- Do:--** Wrap bread well to keep it fresh.
- Do:--** Chill white wines, beer, lager and mineral water before serving.
- Do:--** Make sure the gutter at the back interior of the Larder Fridge is always clear. Check regularly and remove any particles of food which may collect there.
- Do:--** Keep raw meat and poultry below cooked foods and dairy products.
- Do:--** Clean out the salad bins regularly and check that nothing has dripped into them.
- Do:--** Keep food for as short a time as possible and adhere to 'sell by' dates.

DON'T

- Don't:--** Store bananas in your Larder Fridge.
- Don't:--** Store melon in your Larder Fridge. It can be chilled for short periods as long as it is wrapped to avoid it flavoured other food.
- Don't:--** Wash eggs as this removes their natural protective film. Wipe them instead.
- Don't:--** Use eggs straight from the Larder Fridge, especially when making cakes or mayonnaise. Allow them to reach room temperature before use.
- Don't:--** Leave the door open for long periods as this will make the Larder Fridge more costly to run.
- Don't:--** Cover the shelves with any protective materials which may obstruct air circulation through them.
- Don't:--** Let anything touch the cooling plate at the back of the Larder Fridge.
- Don't:--** Try to keep frozen food which has thawed; it should be eaten within 24 hours.
- Don't:--** Store poisonous or any dangerous substances in the Larder Fridge. Your Larder Fridge has been designed for the storage of edible foodstuffs only.
- Don't:--** Consume food which has been stored for an excessive time in the Larder Fridge.
- Don't:--** Put hot or warm food straight into the Larder Fridge.
- Don't:--** Let food juices drip onto other foods in the Larder Fridge.

Fittings supplied

- 2 decor door mounting brackets
- 1 decor door covering trim
- 4 adjusting pins
- 4 retaining nuts
- 22 round head screws
- 4 blanking plugs

Repositioning the Door Hinge (if necessary)

1. Remove the door retaining screws (2) on the top and bottom hinges (Fig B). Lift the door away from the cabinet and place in a safe area.
2. Carefully lever off the blanking plugs (3) using a flat-bladed screwdriver ensuring you do not injure yourself or damage the appliance.
3. Completely remove retaining screws (1) and remove the bracket.
4. Fit the door retaining screws (2) with the bracket onto the opposite side of the door. (Fit the bottom right hand hinge to the top left position and the top right hand hinge to the bottom left position as shown in Fig B.)
5. Fit the retaining screws (1) into the holes left by the blanking plugs, but leave enough room to allow the bracket to fit behind the screw.
6. Position the door such that the bracket fits over the retaining screws (1) and move the door and bracket such that the screws slide into the narrow sections of the bracket holes. Now tighten screws.
7. Insert the blanking plugs into the holes left by the door bracket.

Tools required

- Cross-pointed screwdriver
- 30mm open-ended spanner
- Flat-bladed screwdriver
- 14mm open-ended spanner

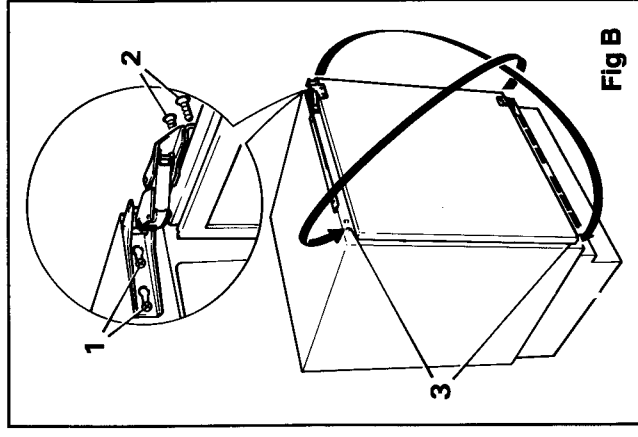

Fig B

Controlling the Temperature

The control dial, on the right-hand side of the Larder Fridge interior, controls the temperature inside the Fridge and is marked 'O' (off), 1,2,3 . . .7.

Which setting is selected will depend on where the Larder Fridge is located, how often you open the door and the room temperature.

A control setting of 4-5 is usually suitable, but if you find the interior is too warm turn the control to a colder

setting (higher number). Similarly, if you find the interior is too cold turn the control to a warmer setting (lower number).

In the summer months, or in conditions giving high temperatures around the Larder Fridge, the compressor has to work harder and run for longer periods. This is quite normal. Conversely, during cold weather the compressor will run for much shorter periods.

Storing Food

You can store most fresh foods in your Integrated Larder Fridge. Recommended maximum storage times are given in the table below.

		Days
Raw fresh meat	joints, steaks, chops	3-5
	offal (liver, kidney etc) minced meat, sausages	2
Cooked meat	including made-up dishes and left-overs	2-3
Poultry	fresh whole (store giblets separately)	2-3
	cooked	2-3
Fish	giblets	2
	raw	1-2
	cooked	2-3
Bacon		7-10
Milk, cream, salad; vegetables		3-4
Weeks		
Butter, margarine and cooking fats		3-4
Cheese	hard	3-4
	cream	1
Eggs		2

All foods should be wrapped or covered to prevent drying out and flavour transference. Plastic bags, containers with lids, foil and plastic stretch wrap are ideal. Never put hot or warm food into your Larder Fridge as this reduces efficiency.

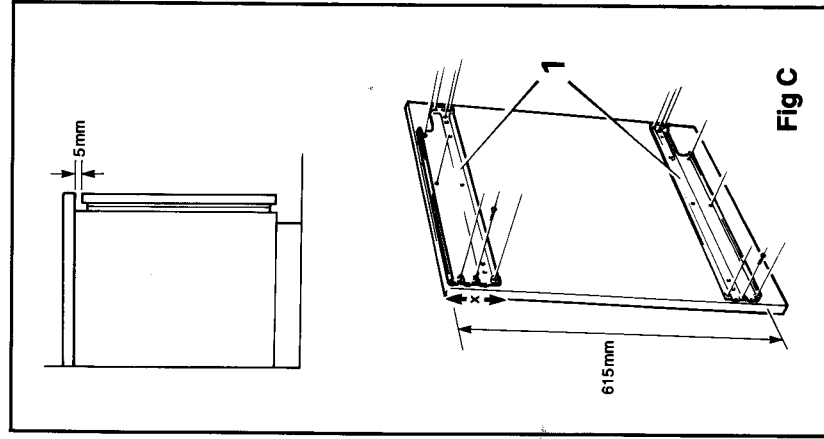

Fig C

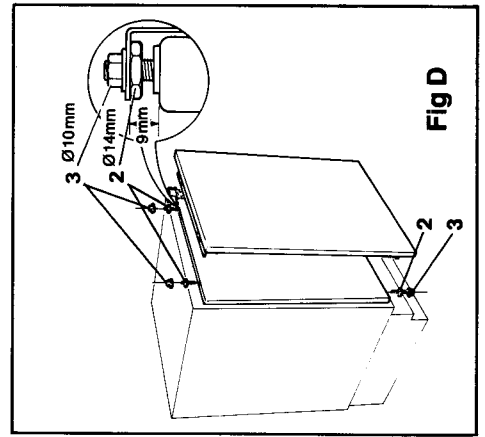

Fig D

Fitting the decor door

- Using a cross-pointed screwdriver attach the decor door mounting brackets (1) on to the decor door, with the round head screws provided (Fig C). Ensure the cut-out section of the bracket is towards the hinge side of the door.
The 15mm positional tolerance (X) allows you to obtain a 5mm clearance between the underside of the work top and the top of the decor door.
- Screw the four adjusting pins (2) fully into the Larder Fridge door (Fig D).
- Position the decor door by locating the larger slots in the lower mounting bracket over the adjusting pins at the bottom of the Larder Fridge door. Secure the door on the pins using the retaining nuts (3) (Fig D). Using a 14mm open-ended spanner unscrew the locating pins at the top of the Larder Fridge door until they engage the smaller of the two slots in the upper mounting bracket. Again lock in place using the retaining nuts (3).

Additional space for storing tall bottles and containers can be obtained by repositioning the centre door commodity rack, the rack can also be removed when cleaning. Simply push up the shelf at the side and remove from the front to replace the shelf, insert the left retaining pins in the rail and snap the right side in place.

Plug the holes in the retaining rails with the plastic stoppers provided (Fig L).

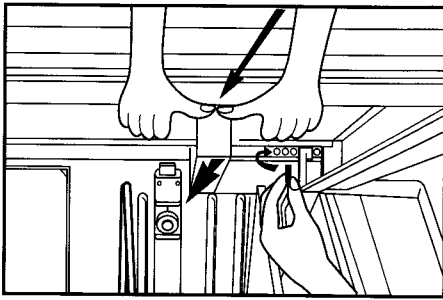

Fig L

Getting your Integrated Larder Fridge ready for use

Before using your Integrated Larder Fridge for the first time the interior, including the door, and all removable parts should be wiped out. Use a damp cloth wrung out in either a solution of one teaspoonful of bicarbonate of soda to one pint of water or Milton diluted according to the manufacturer's instructions.

WARNING: NEVER USE ANY HOUSEHOLD CLEANER OR DETERGENT, ABRASIVE POWDERS OR WAX POLISH. THESE NOT ONLY DAMAGE THE SURFACES, THEY ALSO LEAVE A SMELL IN THE LARDER FRIDGE.

Final check

Before you start using the Larder Fridge, check that

1. it is thoroughly dry inside,
2. air can circulate freely,
3. the feet have been adjusted, ie the feet are firmly on the ground and ensure the appliance is level.

Installing your Integrated Larder Fridge

1. For an 820mm installed height – only adjust the height of the Larder Fridge if it is necessary, using a 30mm open-ended spanner (Fig F). Ensure the Larder Fridge is level.
2. For an 870mm installed height – unscrew the adjustable feet by approximately 50mm (Fig F). Ensure the appliance is level.
3. With the Larder Fridge door open, locate 2 round head screws through the slots (4) in the mounting plate at the top of the Larder Fridge cabinet.
4. Push the Larder Fridge into the required position between your kitchen units until the decor door lies flush with the adjacent units.
5. Screw the mounting plate at the top of the Larder Fridge cabinet into the underside of the worktop (Fig E).

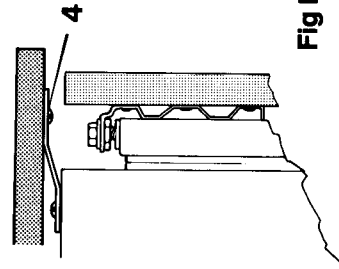

Fig E

Adjusting the plinth depth

1. Open the Larder Fridge door and grip the plinth at the ventilation grill. Pull the plinth out until it lies flush with the adjacent kitchen units or until it joins up with the cut out section of a continuous plinth. A continuous plinth needs to have a section cut away to ensure the ventilation grill is free from obstructions. If the installed height of the appliance is 820mm, then the depth of the continuous plinth needs to be only 90mm (measured from the floor). If the installed height of the appliance is 870mm, then the depth of the continuous plinth needs to be 140mm (measured from the floor) See Fig F.
2. To secure the plinth in position, turn the screws (5) which are located in the top left and right hand corners of the plinth clockwise until they tighten (Fig G).

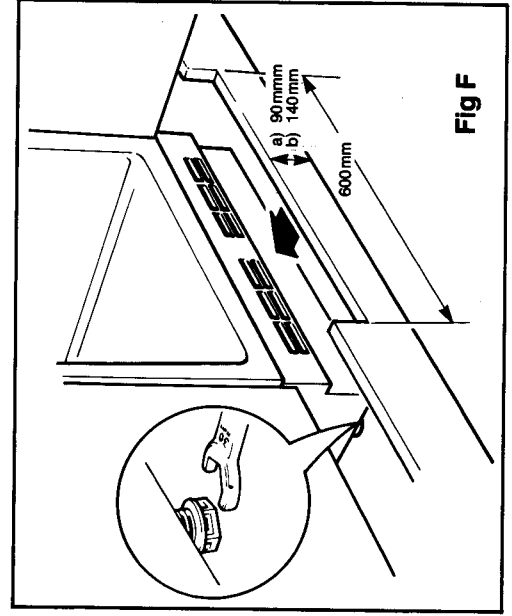

Fig F

Get to know your Integrated Larder Fridge

Adjusting the decor door

1. To adjust the decor door it is first necessary to loosen the top and bottom retaining nuts (3) (Fig D, Page 6).
2. To lower the decor door, screw in the upper adjusting pins and unscrew the lower adjusting pins the required amount until the door is positioned correctly (Fig H).
3. To raise the decor door screw in the bottom adjusting pins and release the upper adjusting pins the required amount.
4. Slight sideways adjustment is possible within the slots on the mounting brackets. When the door is positioned correctly, tighten the retaining nuts (3) (Fig D, Page 6).
5. Fit the cover trim (6) by sliding into place over the top bracket until it snaps into position (Fig Ia). To remove the cover trim, lever it out with a screwdriver, taking care not to allow the screwdriver to slip and cause injury or damage the appliance (Fig Ib).

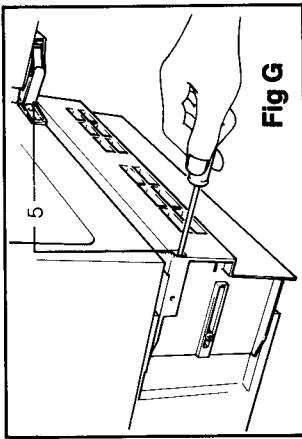

Fig G

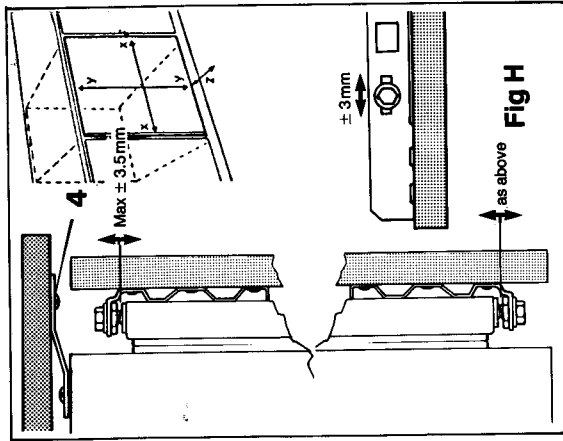

Fig H

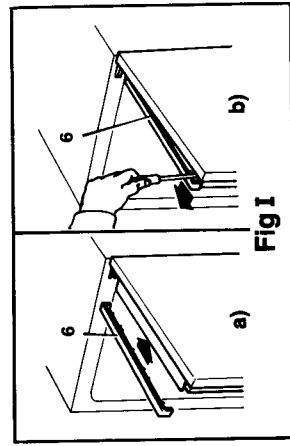
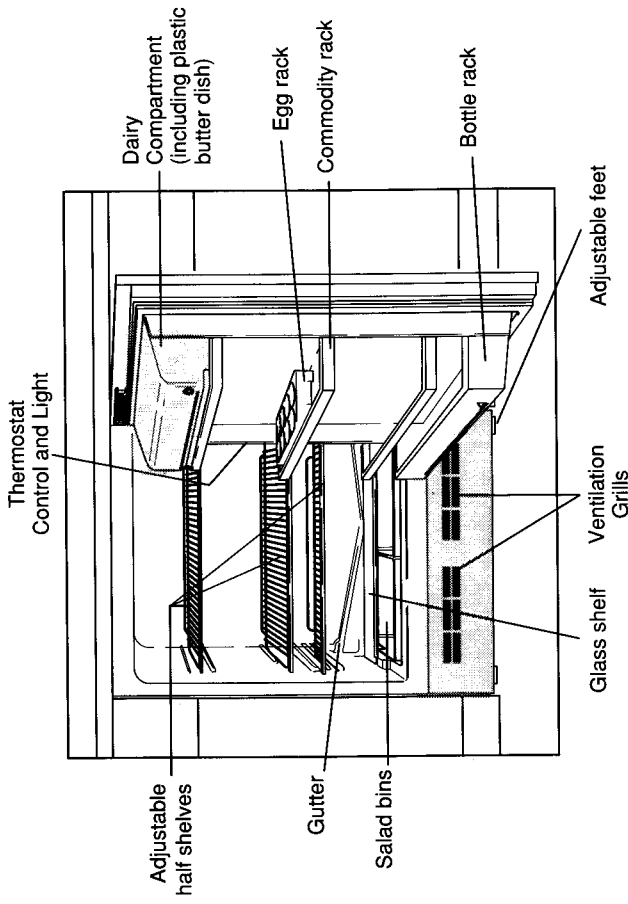

Fig I



WARNING: CHILDREN SHOULD NOT BE ALLOWED TO PLAY WITH THE APPLIANCE OR TAMPER WITH THE CONTROLS.

The shelves can be inserted at various heights to accommodate the items stored in the Larder Fridge. Always insert the shelf with the stop bar of edge facing upwards at the back to prevent the contents freezing to the back of the Larder Fridge.