

Owner's Manual

Bar Refrigerator
with Icemaker

ZIBI240
ZIBS240



Monogram.[®]

Consumer Information

Bar Refrigerator with Icemaker

Introduction

Your new Monogram bar refrigerator with icemaker makes an eloquent statement of style, convenience and kitchen planning flexibility. Whether you chose it for its purity of design or the assiduous attention to detail, you will find that your Monogram bar refrigerator with icemaker's superior blend of form and function will delight you for years to come.

The information on the following pages will help you operate and maintain your bar refrigerator with icemaker properly.

If you have any other questions, visit our Website at: **www.monogram.com**

Contents

Built-In Dimensions	13, 14	Problem Solver	16–18
Care and Cleaning	11, 12	Product Registration	2
Consumer Services	19	Repair Service	3, 19
Controls and Features	8–10	Safety Instructions	4–7
Installation Instructions	14, 15	Warranty	Back Cover
Model and Serial Numbers	2		

Before using your bar refrigerator with icemaker

Read this manual carefully. It is intended to help you operate and maintain your new bar refrigerator with icemaker properly.

Keep it handy for answers to your questions.

If you don't understand something or need more help, there is a list of toll-free consumer service numbers included in the back section of this manual.

OR

Visit our Website at: **www.monogram.com**

Write down the model & serial numbers

You will find them on a label on the ceiling inside the bar refrigerator with icemaker.

Please write these numbers here:

Model Number

Serial Number

Use these numbers in any correspondence or service calls concerning your bar refrigerator with icemaker.

<i>If you received a damaged appliance</i>	The warranty does not cover damage caused after delivery.	Immediately contact the dealer (or builder) that sold you the bar refrigerator with icemaker.
<i>Save time & money</i>	Before you request service, check the Problem Solver in the back of this manual.	It lists causes of minor operating problems that you can correct yourself.
<i>Remove packaging</i>	<p>Before using, be sure all packing materials and tape have been removed.</p> <p>To assure no damage is done to the finish of the product, the safest way to remove the adhesive left from packaging tape on</p>	<p>new appliances is an application of household liquid detergent. Apply with a soft cloth and allow to soak. Wipe dry and then apply an appliance polish to thoroughly clean and protect the surface.</p>
<i>If you need service</i>	<p>To obtain service, see the Consumer Services page in the back of this manual.</p> <p>We are proud of our service and want you to be pleased. If for some reason you are not happy with the service you receive, here are steps to follow for further help.</p> <p>For customers in the USA:</p> <p>FIRST, contact the people who serviced your appliance. Explain why you are not pleased. In most cases, this will solve the problem.</p> <p>NEXT, if you are still not pleased, write all the details—including your phone number—to:</p> <p style="padding-left: 40px;">Manager, Customer Relations GE Appliances Appliance Park Louisville, KY 40225</p>	<p>For customers in Canada:</p> <p>FIRST, contact the people who serviced your appliance. Explain why you are not pleased. In most cases, this will solve the problem.</p> <p>NEXT, if you are still not pleased, write all the details—including your phone number to:</p> <p style="padding-left: 40px;">Manager, Consumer Relations Camco Inc. 1 Factory Lane, Suite 310 Moncton, N.B. E1C 9M3</p>
<i>After installation is completed</i>	<ul style="list-style-type: none"> • Promptly inspect your new Monogram bar refrigerator with icemaker. If it has been damaged, contact the Installer or Dealer immediately. • This bar refrigerator with icemaker must be properly leveled to ensure correct door alignment, door closure and ice production. Contact the Installer if the unit is not level. • The unit should be centered in the opening. In a standard 24" opening, the front face of the Stainless Steel door will be flush with adjacent cabinetry. The front face of the Custom Panel door should be 1/4" forward of adjacent cabinetry. Contact the installer if clearance is not correct. 	<ul style="list-style-type: none"> • Test the door swing. Carefully open and close the door. The door should not rub or catch on adjacent cabinetry. Notify the installer if the door makes contact with cabinetry. <p>Please Contact the Installer or Dealer if you experience any of these problems.</p> <p>Your custom panel (ZIBI240 model only) bar refrigerator with icemaker is shipped with two toekicks, a stainless steel and a black toekick. For shipping purposes, one of the toekicks will be secured to the back or on the inside of the unit, and the second will be installed on the unit. Keep the unused toekick and other unused or removed parts for possible future use.</p>

IMPORTANT SAFETY INSTRUCTIONS

READ AND SAVE THESE INSTRUCTIONS

⚠️ WARNING—When using this appliance, always exercise basic safety precautions, including the following:

- **Use this appliance only for its intended purpose** as described in this Owner's Manual.
 - **This bar refrigerator with icemaker must be properly installed in accordance with the Installation Instructions before it is used.**
 - **Do not allow children to climb, stand or hang on the shelves in the bar refrigerator with icemaker.** They could damage the bar refrigerator with icemaker and seriously injure themselves.
 - **Do not store or use gasoline or other flammable vapors and liquids in the vicinity of this or any other appliance.**
 - **Keep fingers out of the “pinch point” areas:** clearances between the door and between the door and cabinet are necessarily small. Be careful closing the door when children are in the area.
 - **Unplug your bar refrigerator with icemaker before cleaning or making repairs. NOTE:** We strongly recommend that any servicing be performed by a qualified individual.
 - **Before replacing a burned-out light bulb,** the bar refrigerator with icemaker should be turned OFF or unplugged in order to avoid contact with a live wire filament. (A burned-out light bulb may break when being replaced.)
 - **In bar refrigerators with automatic icemakers,** avoid contact with the moving parts of the ejector mechanism, or with the heating element located on the bottom of the icemaker.
- Do not place fingers or hands on the automatic icemaking mechanism while the unit is plugged in.**

⚠️ DANGER: RISK OF CHILD ENTRAPMENT

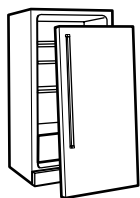

Child entrapment and suffocation are not problems of the past. Junked or abandoned refrigeration products are still dangerous...even if they will sit for “just a few days.” If you are getting rid of your old appliance, please follow these instructions to help prevent accidents.

Before You Throw Away Your Old Refrigeration Product:

- Take off the doors.
- Leave the shelves in place so that children may not easily climb inside.

REFRIGERANTS

All refrigeration products contain refrigerants, which under federal law must be removed prior to product disposal.

If you are getting rid of an old refrigeration product, check with the company handling the disposal about what to do.

IMPORTANTES INSTRUCTIONS DE SÉCURITÉ

LIRE ET CONSERVER CES INSTRUCTIONS

▲AVERTISSEMENT—

Lorsque vous utilisez l'appareil, observez toujours certaines précautions de base, notamment :

- **N'utilisez l'appareil que pour son usage prévu**, comme décrit dans le présent manuel.
- **Installez le réfrigérateur de bar avec machine à glaçons conformément aux directives d'installation avant de l'utiliser.**
- **Ne laissez pas les enfants grimper, s'asseoir, se tenir debout ni se pendre aux clayettes du réfrigérateur de bar avec machine à glaçons.** Ils pourraient endommager le réfrigérateur de bar avec machine à glaçons et se blesser gravement.
- **N'entreposez et n'utilisez pas d'essence ou autres vapeurs et liquides inflammables à proximité de cet appareil ou de tout autre appareil électroménager.**
- **Éloignez les doigts des parties du réfrigérateur où l'on peut facilement se pincer** : les espaces entre les portes et entre les portes et les placards sont toujours étroits. Soyez prudent lorsque vous fermez les portes de l'appareil en présence des enfants.

- **Débranchez votre réfrigérateur de bar avec machine à glaçons avant de le nettoyer et de le réparer. REMARQUE :** Nous vous recommandons vivement de confier toute réparation à un technicien qualifié.
- **Avant de remplacer une ampoule grillée**, le réfrigérateur de bar avec machine à glaçons doit être débranché afin d'éviter tout contact avec un fil sous tension. (Une ampoule grillée peut se briser pendant l'opération).
- **Dans les réfrigérateurs de bar qui ont une machine à glaçons automatique**, évitez de toucher les pièces mobiles du mécanisme d'éjection ou l'élément chauffant situé en bas de la machine à glaçons.
Ne mettez jamais vos doigts ou vos mains sur le mécanisme de machine à glaçons automatique quand votre réfrigérateur est branché.

▲DANGER! RISQUES POUR LES ENFANTS

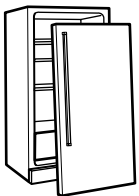

Les enfants pris au piège ou morts d'asphyxie sont toujours d'actualité. Les appareils de réfrigération abandonnés sont toujours aussi dangereux, même si on n'attend que "quelque jours" pour s'en débarrasser. Si vous ne gardez pas votre ancien appareil, veuillez suivre les directives ci-dessous afin de prévenir les accidents.

Avant de vous débarrasser de votre vieux appareil de réfrigération :

- Démontez les portes.
- Laissez les clayettes en place afin d'empêcher les enfants de grimper à l'intérieur.

RÉFRIGÉRANTS

Tous les appareils de réfrigération contiennent des réfrigérants qui, conformément aux lois fédérales, doivent être enlevés avant toute élimination de l'appareil.

Si vous vous débarrassez de vieux appareils de réfrigération, vérifiez, auprès de la société qui s'occupe de leur élimination, ce que vous devez faire.

IMPORTANT SAFETY INSTRUCTIONS

HOW TO CONNECT ELECTRICITY

Do not, under any circumstances, cut or remove the third (ground) prong from the power cord. For personal safety, this appliance must be properly grounded.

The power cord of this appliance is equipped with a 3-prong (grounding) plug which mates with a standard 3-prong (grounding) wall outlet to minimize the possibility of electric shock hazard from this appliance.

Have the wall outlet and circuit checked by a qualified electrician to make sure the outlet is properly grounded.

Where a standard 2-prong wall outlet is encountered, it is your personal responsibility and obligation to have it replaced with a properly grounded 3-prong wall outlet.

Use of a GFI (Ground Fault Interrupter) is not recommended for the bar refrigerator with icemaker.

The appliance should always be plugged into its own individual electrical outlet which has a voltage rating that matches the rating plate. This provides the best performance and also prevents overloading house wiring circuits which could cause a fire hazard from overheated wires.



DO NOT USE AN ADAPTER PLUG TO CONNECT THE BAR REFRIGERATOR WITH ICEMAKER TO A 2-PRONG OUTLET.

DO NOT USE AN EXTENSION CORD WITH THIS APPLIANCE.

Never unplug an appliance by pulling on the power cord. Always grip the plug firmly and pull straight out from the outlet.

Repair or replace immediately all power cords that have become frayed or otherwise damaged. Do not use a cord that shows cracks or abrasion damage along its length or at either end.

When moving the appliance, be careful not to roll over or damage the power cord.

SAVE THESE INSTRUCTIONS

IMPORTANTES INSTRUCTIONS DE SÉCURITÉ

RACCORDEMENT ÉLECTRIQUE

Ne coupez ni retirez en aucun cas la troisième broche (mise à la terre) de la fiche du cordon d'alimentation. Pour votre sécurité, cet appareil doit être correctement mis à la terre.

Le cordon d'alimentation de cet appareil est muni d'une fiche à 3 broches (mise à la terre) qui se branche dans une prise mural ordinaire à 3 alvéoles (mise à la terre) pour réduire au minimum les risques du chocs électriques.

Faites examiner la prise de courant et le circuit par un électricien qualifié pour vous assurer que la prise est correctement mise à la terre.

Si la prise murale est du type standard à 2 alvéoles, il vous incombe de la faire remplacer par une prise à 3 alvéoles correctement mise à la terre.

L'appareil doit toujours être branché dans sa propre prise de courant, dont la tension nominale est identique à celle indiquée sur la plaque signalétique.

L'utilisation d'un disjoncteur de fuite à la terre est recommandée pour le réfrigérateur de bar avec machine à glaçons.

Cette précaution est recommandée pour garantir un rendement optimum et éviter une surcharge des circuits électriques de la résidence, ce qui pourrait créer un risque d'incendie par surschauffe des fils.



N'UTILISEZ JAMAIS UNE PRISE À ADAPTATEUR POUR LE RÉFRIGÉRATEUR DE BAR AVEC MACHINE À GLAÇONS À UNE PRISE BIPOLAIRE.

N'UTILISEZ JAMAIS DE RALLONGE AVEC CET APPAREIL.

Ne débranchez jamais l'appareil en tirant le cordon d'alimentation. Saisissez fermement la fiche du cordon et tirez droit pour la retirer de la prise.

Réparez ou remplacez immédiatement tout cordon effiloché ou endommagé. N'utilisez pas un cordon fendillé ou présentant des signes d'usure.

Lorsque vous déplacez l'appareil, faites attention de ne pas la faire rouler sur le cordon d'alimentation afin de ne pas l'endommager.

CONSERVEZ CES DIRECTIVES

Controls and Features

Bar Refrigerator with Icemaker

Temperature control

The temperature display shows the actual temperature of the bar refrigerator with icemaker. The actual temperature may vary slightly from the set temperature based on factors such as door openings, amount of food and room temperature.

To change the temperature setting, press the WARMER or COLDER pads until you reach the desired set temperature. After 5 seconds, the display will return to the actual temperature.

After making adjustments, allow 12 to 24 hours for the bar refrigerator with icemaker to reach the temperature you have set and before making any further adjustments.

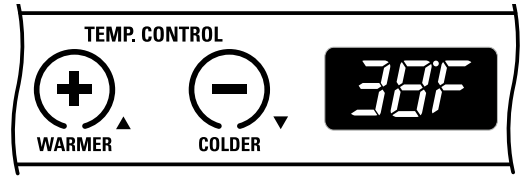

NOTE: The icemaker temperature is not displayed.

Temperature Settings

Minimum: 34°F (1.1°C)

Maximum: 45°F (7.2°C)

Child control lockout

This child control lockout feature prevents unwanted changes to your temperature settings.

After the desired temperature is set, the temperature can be locked. To lock, press both the + and – pads at the same time for five seconds. To unlock, press both + and – pads for five seconds.

Unit ON/OFF

This pad stops cooling in the bar refrigerator with icemaker, turns off the temperature controls and removes power to the light circuit.

NOTE: The icemaker is on a separate on/off switch. To remove power from the icemaker See Automatic Icemaker section.

Press this pad for a minimum of 3 seconds to turn the bar refrigerator with icemaker on or off, or unplug the unit for long vacations or absences, or when cleaning the unit or changing the light bulb.



Glass shelves

Tempered glass shelves in the bar refrigerator with icemaker are removable for easy cleaning or for storing larger items.

To remove a shelf, open the door completely to avoid potential damage to the gasket. Lift up on the back of the shelf slightly. Tilt the shelf to one side at an angle while pulling forward.

Appearance may vary

To replace a shelf, open the door completely to avoid potential damage to the gasket. Tilt the shelf to one side at an angle and slide toward the back wall, placing one side onto the shelf support. Place the other side onto the opposite shelf support. Ensure rear locking tabs are engaged. When installed properly, the shelf will not slide forward when gently pulled.

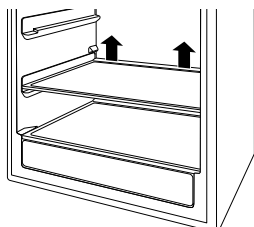

To remove, lift up on the back of the shelf

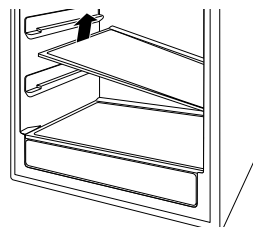

Tilt the shelf at an angle while removing or replacing

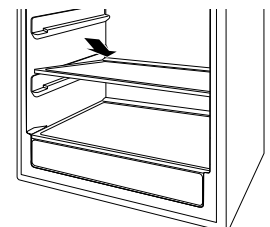

Place in slots when replacing the shelf

Controls and Features

Bar Refrigerator with Icemaker

Automatic icemaker

The icemaker will produce seven cubes per cycle—approximately 100–130 cubes in a 24-hour period, depending on freezer compartment temperature, room temperature, number of door openings and other use conditions.

If the bar refrigerator with icemaker is operated before the water connection is made to the water valve, set the icemaker power switch to **O (off)**.

When the unit has been connected to the water supply, set the icemaker power switch to **I (on)**. The green light will come on.

The icemaker will fill with water when it cools to 15°F (–10°C). A newly installed bar refrigerator with icemaker may take 12 to 24 hours to begin making ice cubes.

You will hear a buzzing sound each time the icemaker fills with water.

Throw away the first few batches of ice to allow the water line to clear.

Be sure nothing interferes with the sweep of the feeler arm.

When the bin fills to the level of the feeler arm, the icemaker will stop producing ice. It is normal for several cubes to be joined together.

If ice is not used frequently, old ice cubes will become cloudy, taste stale and shrink.

If ice cubes get stuck in the icemaker, the green power light will blink. To correct this, set the icemaker power switch to **O (off)** and remove the cubes. Set the icemaker power switch to **I (on)** to restart the icemaker.

After the icemaker has been turned on again, there will be a delay of about 45 minutes before the icemaker resumes operations.

NOTE: In homes with lower-than-average water pressure, you may hear the icemaker cycle multiple times when making one batch of ice.

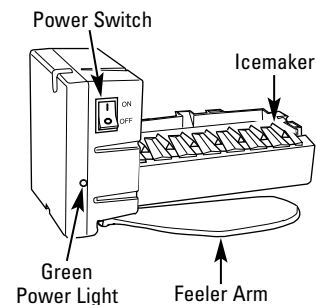

Ice storage bin

To remove, pull the icemaker drawer fully open and remove the transportable ice storage bin by lifting up and out.

NOTE: Ice can fall behind the ice storage bin. Prior to replacing the bin, check for any fallen ice.

If the ice storage bin is removed from the refrigerator for an extended period of time, we recommend setting the icemaker power switch to **O (off)**.

To replace, grasp the side of the right side of the bin with the higher edge so that the angled side is against the drawer front. Lower the bin into place and close the drawer.

CAUTION: Failure to install properly could cause potential damage to the icemaker.

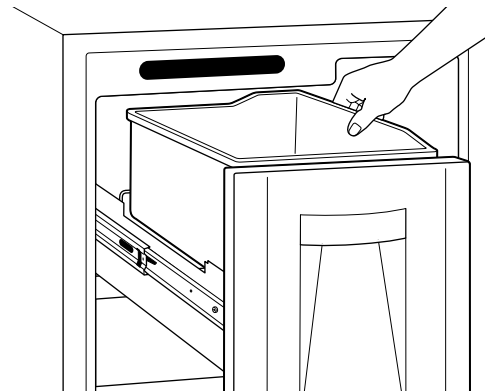

The ice storage bin is dishwasher safe, top rack only.

Ice scoop

The bar refrigerator with icemaker includes an ice scoop in the ice storage bin. To maximize ice bin capacity, store the ice scoop as shown. Do NOT wash the ice scoop in the dishwasher. For cleaning, handwash in mild soapy water or use the baking soda solution noted in Cleaning the inside section.

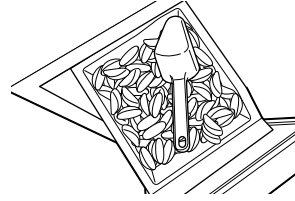

Loading tips and suggestions

The bottom full extension drawer holds five bottles and is loaded with necks facing the rear. Tall bottles should not be loaded on the bottom drawer because they may prevent the door from closing.

- **Do not block the thermistor**, located on the right hand side, just above the top shelf of the bar refrigerator with icemaker. Blocking the thermistor could impair the air circulation and temperature control.

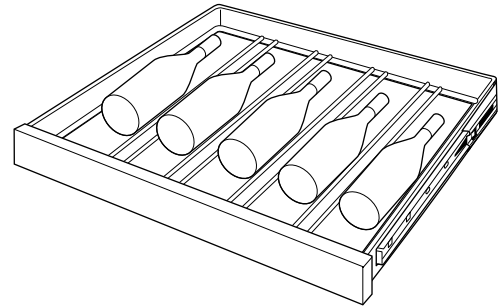

Bottom drawer arrangement

Removing full extension drawer

To remove:

1. Pull the full extension drawer out to the STOP position.
2. Push the tab on right drawer guide down while pulling the tab on left guide up, and pull the drawer out.

To replace:

1. Push the drawer slide arm back into the unit.
2. Pull the small slide sub assembly completely forward.
3. Insert the sides of the drawer back into the guides.
4. Push until the tabs lock into place.

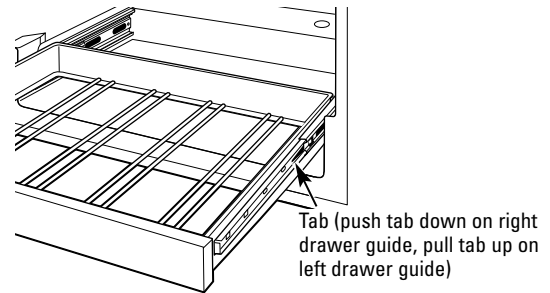

Appearance may vary

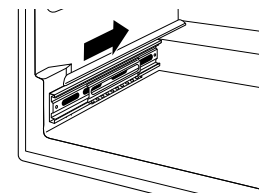

To replace, push drawer slide arm back into unit

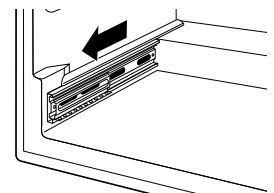

Pull small slide sub assembly completely forward

NOTE: Make sure the tabs on the full extension drawer guides are fully engaged before loading any bottles. Pull the drawers out all the way to the STOP position and push back in several times to make sure locking tabs are properly engaged.

Interior fan

The interior fan is located in the rear wall of the bar refrigerator with icemaker and is designed to run continuously to help maintain the proper cooling temperature.

In most instances, the interior fan will run when the door is open. However, it will not operate when the door is opened during a defrost cycle.

Care and Cleaning

Bar Refrigerator with Icemaker

For your safety

Turn the bar refrigerator with icemaker OFF or unplug the unit before cleaning. Turn the bar refrigerator with icemaker OFF by pressing the button on the control panel a minimum of 3 seconds until the light turns off.

Gasket

The main door and icemaker compartment gaskets may be cleaned with mild soap and water, a baking soda solution or a mild scouring powder. Rinse and dry well after cleaning.

After cleaning the gaskets, apply a thin layer of paraffin wax or petroleum jelly to the gaskets. This helps keep the gaskets from sticking and bending out of shape.

Light bulb replacement

Turn the bar refrigerator with icemaker OFF before replacing the light bulb.

To remove the light shield, pull the tab in the bottom center of the shield. Replace with a 15 watt appliance bulb.

In the event of a power failure

If the power fails, open the door as infrequently as possible to maintain the temperature.

Do not store or use gasoline or other flammable vapors and liquids in the vicinity of this or any other appliance.

Preparing for vacation

For long vacations or absences, remove food and turn the bar refrigerator with icemaker OFF. Clean the interior (see Cleaning the Inside section)

For shorter vacations, remove perishable foods and leave controls at regular settings. However, if the room temperature is expected to drop below 60°F (16°C), follow the same instructions as for long vacations.

Set the icemaker power switch to the **O (off)** position and be sure to shut off the water supply to the refrigerator.

Preparing to move

Secure all loose items such as shelves and drawers by taping them securely in place to prevent damage.

Be sure the bar refrigerator with icemaker stays in an upright position during moving.

For your safety

Turn the bar refrigerator with icemaker OFF or unplug the unit before cleaning. Turn the bar refrigerator with icemaker OFF by pressing the button on the control panel a minimum of 3 seconds until the light turns off.

Cleaning the outside

Door handles and trim—Clean with a cloth dampened with soapy water. Dry with a soft cloth.

Keep the outside clean. Wipe with a clean cloth lightly dampened with mild liquid dish detergent. Dry with a clean, soft cloth.

Do not wipe the refrigerator with a soiled dish cloth or wet towel. These may leave a residue that can damage the finish. Do not use scouring pads, powdered cleaners, bleach or cleaners containing bleach because these products can scratch and damage the finish.

Stainless Steel—Regularly clean and polish the stainless steel exterior and handle with a commercially available stainless steel cleaner such as Stainless Steel Magic™ to preserve and protect the fine finish. Stainless Steel magic is available through GE Parts and Accessories, 800.626.2002 or GEAppliances.com. Order part number WX10X15.

To avoid scratching the fine finish of the stainless steel, wipe in the same direction as the grain when polishing or cleaning any stainless steel surface. The grain on the bar refrigerator with icemaker door runs top to bottom.

Do not use appliance wax or polish on the stainless steel.

Warranty does not cover damage due to improper cleaning methods.

Cleaning the inside

Unplug the bar refrigerator with icemaker before cleaning. If this is not practical, turn the unit OFF and wring excess moisture out of the cloth or sponge when cleaning around switches, lights or controls.

Use warm water and baking soda solution—about a tablespoon (15 ml) of baking soda to a quart (1 liter) of water. This both cleans and neutralizes odors. Thoroughly rinse and wipe dry.

Other parts of the bar refrigerator with icemaker—including the door gaskets, drawer, icemaker, ice scoop and glass shelves—can be cleaned the same way. Only the ice storage bin is dishwasher safe, top rack only.

Avoid cleaning cold glass shelves with hot water because the extreme temperature difference may cause them to break. Handle glass shelves carefully. Rough handling of tempered glass can cause it to shatter.

Built-In Dimensions

Bar Refrigerator with Icemaker

Installation dimensions

*stainless steel
(ZIBS240 model)*

The bar refrigerator with icemaker can be a freestanding model or can be built in using the cut-out dimensions below.

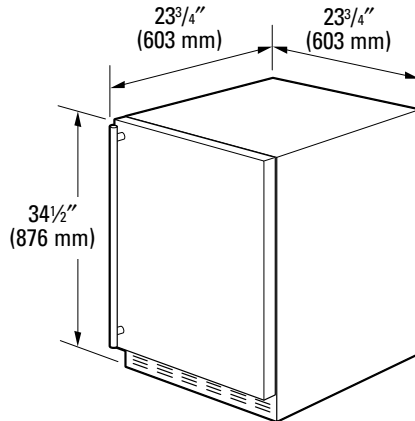

Product dimensions:

Height: 34 1/2" (876 mm)
Width: 23 3/4" (603 mm)
Depth: 23 3/4" (603 mm)

NOTE:

Handle and handle standoff depth is 2 1/4".

When building in the bar refrigerator with icemaker, be sure to allow for a full door swing so you have full access to the pull-out full extension vegetable pan.

See the Installation Instructions (Pub. No. 31-51544) for complete directions.

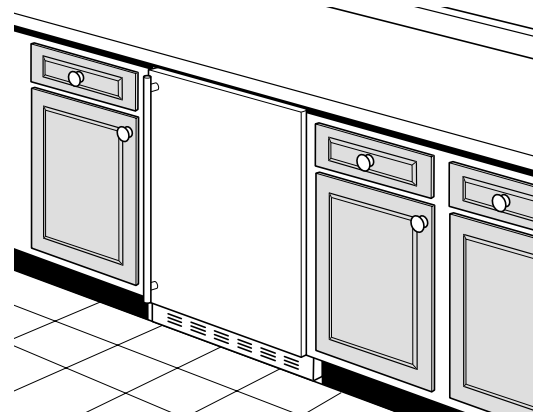

Cut-out dimensions:

Height: 34 1/2" (876 mm) minimum
Width: 23 3/4" (603 mm) minimum
Depth: 24" (610 mm)

Installation dimensions

*custom panel
(ZIBI240 model)*

The bar refrigerator with icemaker can be a freestanding model or can be built in using the cut-out dimensions below.

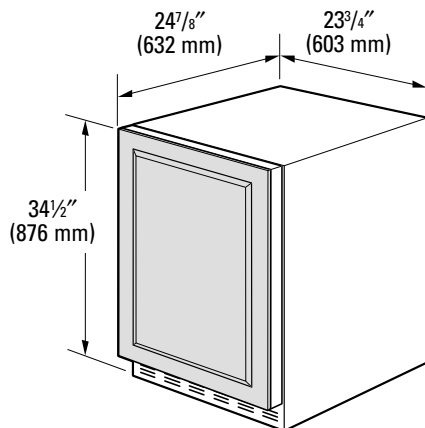

Product dimensions:

Height: 34 1/2" (876 mm)
Width: 23 3/4" (603 mm)
Depth: 24 7/8" (632 mm)

NOTE:

Handle is not supplied.

When building in the bar refrigerator with icemaker, be sure to allow for a full door swing so you have full access to the pull-out full extension vegetable pan.

See the Installation Instructions (Pub. No. 31-51544) for complete directions.

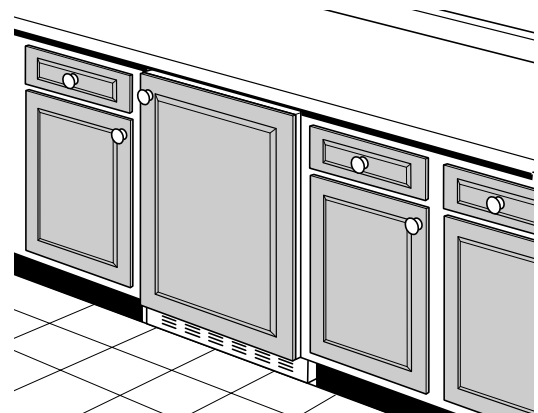

Cut-out dimensions:

Height: 34 1/2" (876 mm) minimum
Width: 23 3/4" (603 mm) minimum
Depth: 24" (610 mm)

Product clearances

The bar refrigerator with icemaker is factory set for a 110° door swing.

When installed in a corner:

Check the model number and allow the appropriate clearance for the 90° door swing and to allow racks to slide out.

- ZIBS240 – 4" minimum to wall.
- ZIBI240 – 4-1/2" minimum to wall.

Check the model number and allow the appropriate clearance for the 110° door swing.

- ZIBS240 – 14" minimum to wall.
- ZIBI240 – 16" minimum to wall.

NOTE: Clearances are based on the recommended 2-1/4" handle standoff depth. Custom handle clearances may vary depending on the standoff of the custom handle.

Choose the location:

- These products may be closed in on the top and three sides as long as the front is unobstructed for air circulation and proper access to the door.

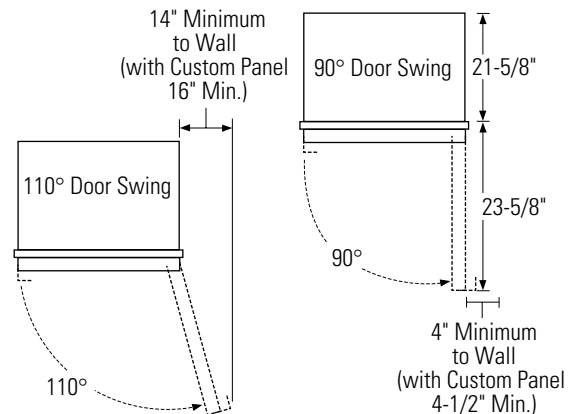

- Do not install these products where the temperature will go below 55°F (13°C) or above 90°F (32°C).
- Do not install where it will be subject to direct sunlight, heat or moisture.

Black or Stainless Steel Toekick Options

Your custom panel (ZIBI240 model only) bar refrigerator with icemaker is shipped with two toekicks, a stainless steel and a black toekick. For shipping purposes, one of the toekicks will be secured to the back or inside of the unit, and the second will be installed on the unit. Keep the unused toekick and other unused or removed parts for possible future use.

Installing custom 3/4" door panel and handle (ZIBI240 model only)

3/4" Overlay Panel Dimensions

Model ZIBI240 requires a field-installed overlay door panel.

- The overlay panel must be secured to a 1/4" thick backer panel that slides into the trim. A .10" thick spacer panel must be placed between the overlay and backer panel.
- A custom handle of your choice, supplied by your cabinet maker, must be installed on this overlay panel. Countersink all screws into the backer panel. Screws cannot protrude from the backer panel.

NOTE: Maximum total weight for custom door panel is 25 pounds.

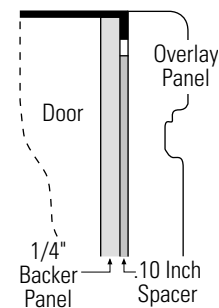

	3/4" Overlay Panel Dimensions (in inches)	
	A (Width)	B (Height)
1/4" Backer	23-3/16"	29-9/16"
0.10" Spacer	22-1/2"	29-1/16"
3/4" Overlay	23-5/8"	30"

Installing custom 3/4" door panel and handle (cont.) (ZIBI240 model only)

Assemble overlay panels with glue and screws:

1. Center spacer panel on the backer panel, left to right and top to bottom. Secure the panels with glue.
2. Center the spacer/backer panel on the overlay panel. Secure with glue and screws. Countersink all screws into the backer panel.

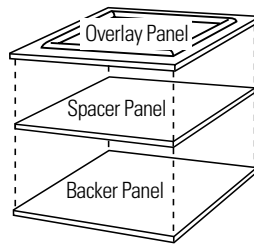

screws into the backer panel. Screws cannot protrude from the backer panel.

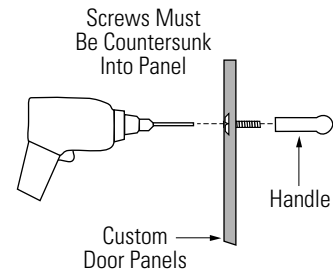

Custom Panel Hinge Routing Dimensions

Use a 3/4" router bit to cut a notch into the back side of the assembled panel 3/8" toward the front of the overlay panel, 3/4" deep and 7/8" wide.

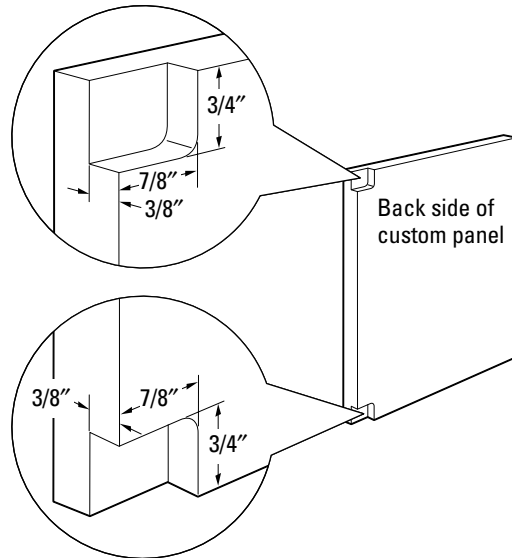

4. Slide overlay panel into the door trim.

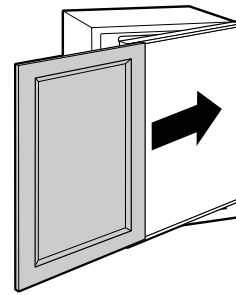

5. Reinstall the side trim using the trim screws removed earlier.

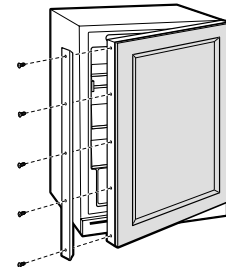

Install custom door panel and handle:

1. Open door to 90°.
2. Remove 5 screws holding trim; lift off trim. Retain screws.

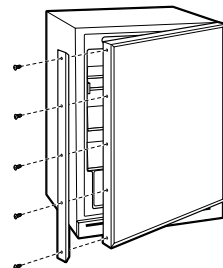

6. Place the brushed decorative cover over the side trim to hide the screw heads. Ensure side trim is aligned top to bottom and front to back. Snap into place.

NOTE: For shipping purposes, the brushed decorative cover will be secured to the front of the unit.

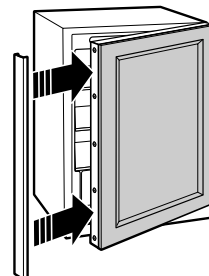

3. A custom handle of your choice, supplied by your cabinet maker, must be installed onto the overlay panel before the panels are slid into the trim. Countersink all

Normal operating sounds

Newer appliances sound different from older appliances. Modern appliances have more features and use newer technology.

Do you hear what I hear? These sounds are normal.

HUMMM... WHOOSH...

- The new high efficiency compressor may run faster and longer than your old appliance and you may hear a high-pitched hum or pulsating sounds while it is operating.
- Sometimes the appliance runs for an extended period, especially when the doors are opened frequently.
- You may hear a whooshing sound when the doors close. This is due to pressure equalizing within the appliance.
- The cabinet fan runs continuously except when the door is opened.

WHIR!



- You may hear the fans spinning at high speeds. This happens when the appliance is first plugged in, when the door is opened frequently or when a large amount of food is added to the appliance. The fans help maintain desired temperatures.
- If the door is open for over 3 minutes, you may hear the fans come on in order to cool the light bulbs.
- The fans change speeds in order to provide optimal cooling and energy savings.

CLICKS, POPS, CRACKS and CHIRPS

- You may hear clicking, cracking or popping sounds when the appliance cools to the correct temperature or immediately following defrost.
- The electronic control board may cause a clicking sound when relays activate to control appliance components.
- Expansion and contraction of cooling coils during and after defrost can cause cracking or popping sounds.
- After an icemaking cycle, you may hear the ice cubes dropping into the ice bucket.

WATER SOUNDS



- The flow of refrigerant through the freezer cooling coils may make a gurgling noise like boiling water.
- Water dropping on the defrost heater can cause a sizzling, popping or buzzing sound during the defrost cycle.
- A water dripping noise may occur during the defrost cycle as ice melts from the evaporator and flows into the drain pan.
- Closing the door may cause a gurgling sound due to pressure equalization.



*For additional information on normal icemaker and dispenser operating sounds, see the **Automatic Icemaker** section in the *Bar Refrigerator with Icemaker Owner's Manual* only.*

The Problem Solver

Bar Refrigerator with Icemaker

*Questions?
Use this
problem
solver!*

PROBLEM	POSSIBLE CAUSE
APPLIANCE DOES NOT OPERATE	<ul style="list-style-type: none"> • Appliance may be in defrost cycle when compressor motor does not operate for about 30 minutes. • Appliance is so quiet that most of the time you will hear low or no operating noise. • Controls are set to OFF. Press ON/OFF button on control panel for a minimum of 3 seconds. • If interior light is not on, appliance may not be plugged in at wall outlet. Push the plug completely into the wall outlet. • The fuse is blown/circuit breaker is tripped. Replace fuse or reset the breaker. • The appliance is in showroom mode. Unplug it and plug it back in.
VIBRATION OR RATTLING (Slight vibration is normal.)	<ul style="list-style-type: none"> • Adjust the leveling legs as shown in the Installation Instructions.
COMPRESSOR MOTOR OPERATES FOR LONG PERIODS OR CYCLES ON AND OFF FREQUENTLY	<ul style="list-style-type: none"> • Normal when appliance is first plugged in. Wait 24 hours for the appliance to completely cool down. • Often occurs when large amounts of food are placed in appliance. This is normal. • Door left open or package holding door open. • Hot weather or frequent door openings. This is normal. • Temperature control set at the coldest setting. See Temperature Control.
FRESH FOOD COMPARTMENT TOO WARM	<ul style="list-style-type: none"> • Temperature control not set cold enough. See Temperature Control. Allow 12 to 24 hours for temperature to change. • Warm weather or frequent door openings. • Door left open for long time. • Package may be holding door open. • Thermistor may be blocked, which can affect the overall temperature. The thermistor is located on the right hand side just above the top shelf.
FROST OR ICE CRYSTALS ON REAR WALL	<ul style="list-style-type: none"> • Too frequent or too long door openings. • Thermistor may be blocked, which can affect the overall temperature. The thermistor is located on the right hand side just above the top shelf.
AUTOMATIC ICEMAKER DOES NOT WORK	<ul style="list-style-type: none"> • Icemaker power switch is in the O (off) position. • Water supply turned off or not connected. See Installation Instructions. • Freezer compartment too warm. Allow 24 hours for the appliance to completely cool down. • Piled up cubes in storage bin cause icemaker to shut off. Level cubes in bin. • Ice cubes stuck in icemaker (green power light on the icemaker is blinking). Turn off the icemaker, remove cubes and turn the icemaker back on.

The Problem Solver

Bar Refrigerator with Icemaker

*Questions?
Use this
problem
solver!*

PROBLEM	POSSIBLE CAUSE
FREQUENT “BUZZING” SOUND	<ul style="list-style-type: none"> • Icemaker power switch is in the I (on) position, but the water supply to the appliance has not been connected or is kinked. Set the power switch to the O (off) position. Keeping it in the I (on) position will damage the water valve or straighten the water supply line.
ICE CUBES HAVE ODOR/TASTE	<ul style="list-style-type: none"> • Old cubes need to be discarded. • Ice storage bin needs to be emptied and washed. • Unsealed packages in fresh food compartment may be transmitting odor/taste to ice cubes. • Interior of appliance needs cleaning. See Care and Cleaning.
SLOW ICE CUBE FREEZING	<ul style="list-style-type: none"> • Door may have been left open.
APPLIANCE HAS ODOR	<ul style="list-style-type: none"> • Interior needs cleaning. See Care and Cleaning. • Keep open box of baking soda in appliance; replace every 3 months.
DOOR NOT CLOSING PROPERLY	<ul style="list-style-type: none"> • Door gasket is sticking or folding over. Apply petroleum jelly or paraffin wax to the face of the gasket. • The door is hitting an internal component inside the appliance. Adjust interior components to prevent interference.
MOISTURE FORMS ON OUTSIDE OF APPLIANCE	<ul style="list-style-type: none"> • Not unusual during periods of high humidity. Wipe surface dry. • Door left open or package holding door open.
MOISTURE COLLECTS INSIDE	<ul style="list-style-type: none"> • Too frequent or too long door openings. • In humid weather, air carries moisture into appliance when doors are opened.
INTERIOR LIGHT DOES NOT WORK	<ul style="list-style-type: none"> • No power at outlet. • Light bulb needs replacing. See Care and Cleaning.
HOT AIR FROM BOTTOM OF APPLIANCE	<ul style="list-style-type: none"> • Normal air flow cooling motor. In the refrigeration process, it is normal that heat be expelled in the area under the appliance. Some floor coverings are sensitive and will discolor at these safe and normal temperatures.
APPLIANCE NEVER SHUTS OFF BUT TEMPERATURES ARE OK	<ul style="list-style-type: none"> • Adaptive defrost keeps compressor running during door openings. This is normal. The appliance will cycle off after the door remains closed for two hours. • Normal operation in extreme temperatures.
ACTUAL TEMPERATURE NOT EQUAL TO SET TEMPERATURE	<ul style="list-style-type: none"> • Unit just plugged in. Allow 24 hours for the system to stabilize. • Door open for too long. Allow 24 hours for the system to stabilize. • Warm contents added to appliance. Allow 24 hours for the system to stabilize. • Defrost cycle is in process. Allow 24 hours for the system to stabilize. • Thermistor may be blocked, which can affect the overall temperature. The thermistor is located on the right hand side just above the top shelf.
TEMPERATURE WILL NOT ADJUST	<ul style="list-style-type: none"> • Temperature may be in lockout mode. Press both + and – pads for 5 seconds to unlock the temperature. • Thermistor may be blocked, which can affect the overall temperature. The thermistor is located on the right hand side just above the top shelf.

With the purchase of your new Monogram appliance, receive the assurance that if you ever need information or assistance from GE, we will be there. All you have to do is call—toll-free!

GE Answer Center®

**In the USA:
800.626.2000**

Whatever your question about any Monogram major appliance, GE Answer Center® information service is available to help. Your call—and your question—will be answered promptly and courteously. And you can call any time. GE Answer Center® service is open 24 hours a day, 7 days a week.

OR

Visit our Website at: www.monogram.com

In Canada, call 1.888.880.3030.

In-Home Repair Service

**In the USA:
800.444.1845**

**In Canada:
1.888.880.3030**

A GE consumer service professional will provide expert repair service, scheduled at a time that's convenient for you. Many GE Consumer Service company-operated locations offer you service today or tomorrow, or at your convenience (7:00 a.m. to 7:00 p.m. weekdays, 9:00 a.m. to 2:00 p.m. Saturdays). Our factory-trained technicians know your appliance inside and out—so most repairs can be handled in just one visit.

For Customers With Special Needs...

**In the USA:
800.626.2000**

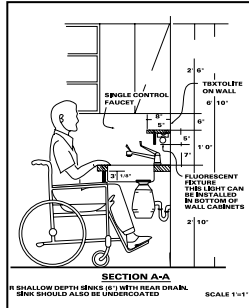

GE offers Braille controls for a variety of GE appliances, and a brochure to assist in planning a barrier-free kitchen for persons with limited mobility.

Consumers with impaired hearing or speech who have access to a TDD or a conventional teletypewriter may call 800.TDD.GEAC (800.833.4322) to request information or service.

Service Contracts

**In the USA:
800.626.2224**

**In Canada:
1.888.880.3030**

You can have the secure feeling that GE Consumer Service will still be there after your warranty expires. Purchase a GE contract while your warranty is still in effect and you'll receive a substantial discount. With a multiple-year contract, you're assured of future service at today's prices.

Parts and Accessories

**In the USA:
800.626.2002**

**In Canada:
1.888.880.3030**

Individuals qualified to service their own appliances can have parts or accessories sent directly to their home. The GE parts system provides access to over 47,000 parts...and all GE Genuine Renewal Parts are fully warranted. VISA, MasterCard and Discover cards are accepted.

User maintenance instructions contained in this manual cover procedures intended to be performed by any user. Other servicing generally should be referred to qualified service personnel. Caution must be exercised, since improper servicing may cause unsafe operation.

Warranty

Bar Refrigerator with Icemaker

YOUR MONOGRAM BAR REFRIGERATOR WITH ICEMAKER WARRANTY Staple sales slip or canceled check here. Proof of original purchase date is needed to obtain service under warranty.

WHAT IS COVERED

From the Date of the Original Purchase

FULL ONE-YEAR WARRANTY

For one year from date of original purchase, we will provide, free of charge, parts and service labor in your home to repair or replace *any part of the bar refrigerator with icemaker* that fails because of a manufacturing defect.

FULL FIVE-YEAR WARRANTY

For five years from date of original purchase, we will provide, free of charge, parts and service labor in your home to repair or replace *any part of the sealed refrigerating system* (the compressor, condenser, evaporator and all connecting tubing) that fails because of a manufacturing defect.

.....
This warranty is extended to the original purchaser and any succeeding owner for products purchased for ordinary home use in the 48 mainland states, Hawaii, Washington, D.C. or Canada. In Alaska the warranty is the same except that it is LIMITED because you must pay to ship the product to the service shop or for the service technician's travel costs to your home.

All warranty service will be provided by our Factory Service Centers or by our authorized Customer Care® servicers during normal working hours.

Should your appliance need service, during warranty period or beyond, in the USA call 800.444.1845. In Canada: 888.880.3030.

WHAT IS NOT COVERED

- Service trips to your home to teach you how to use the product.
 - Replacement of house fuses or resetting of circuit breakers.
 - Damage to the product caused by accident, fire, floods or acts of God.
 - Failure of the product if it is used for other than its intended purpose or used commercially.
 - Replacement of the light bulbs.
 - Improper installation, delivery or maintenance.
- If you have an installation problem, contact your dealer or installer. You are responsible for providing adequate electrical, plumbing and other connecting facilities.**
- Loss of food due to spoilage (in the USA only).
 - Incidental or consequential damage caused by possible defects with this appliance.
 - Damage caused after delivery.

Some states/provinces do not allow the exclusion or limitation of incidental or consequential damages, so the above limitation or exclusion may not apply to you. This warranty gives you specific legal rights, and you may also have other rights which vary from state to state/province to province. To know what your legal rights are in your state/province, consult your local or state/provincial consumer affairs office or your state's Attorney General.

**Warrantor in USA: General Electric Company,
Louisville, KY 40225**

Warrantor in Canada: Camco Inc.



Monogram.®

*GE Consumer & Industrial
Louisville, KY 40225*

©2004 GE Company

197D5891P004
49-60308-4

11-04 JR

Printed in Slovenia