

*Lenox Sound*<sup>®</sup>

# COMPACT DISC PLAYER

AM/FM STEREO CASSETTE RECORDER  
WITH DETACHABLE SPEAKERS

MODEL CD-1492

## OPERATING INSTRUCTIONS

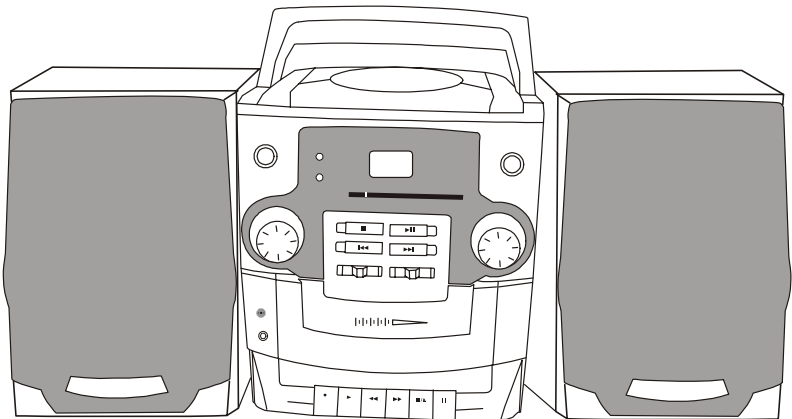

- **PLAYS MUSIC COMPACT DISCS**
- **FULLY PROGRAMMABLE CD PLAYER WITH REPEAT**
- **RECEIVES AM/FM STEREO BROADCASTS**
- **BASS BOOST SWITCH**
- **RECORDS FROM CD, RADIO, OR BUILT-IN MICROPHONE**
- **DETACHABLE SPEAKER SYSTEM**
- **FM STEREO AND POWER LED INDICATORS**
- **2 WAY POWER - AC/DC**
- **REQUIRES 8 SIZE "D" BATTERIES**

---

PLEASE READ CAREFULLY BEFORE USE

IB-CD1492(AD)-WM-E-031402

## WARNING

TO PREVENT FIRE OR SHOCK HAZARD, DO NOT USE THE PLUG WITH AN EXTENSION CORD, RECEPTACLE OR OTHER OUTLET UNLESS THE BLADES CAN BE FULLY INSERTED TO PREVENT BLADE EXPOSURE. TO PREVENT FIRE OR SHOCK HAZARD, DO NOT EXPOSE THIS APPLIANCE TO RAIN OR MOISTURE.



The lightning flash with arrowhead symbol, within an equilateral triangle, is intended to alert the user to the presence of uninsulated "dangerous voltage" within the product's enclosure that may be of sufficient magnitude to constitute a risk of electric shock to persons.

### WARNING

**RISK OF ELECTRIC SHOCK  
DO NOT OPEN**

**WARNING: TO REDUCE THE RISK OF ELECTRIC SHOCK, DO NOT REMOVE COVER (OR BACK). NO USER SERVICEABLE PARTS INSIDE. REFER SERVICING TO QUALIFIED SERVICE PERSONNEL.**



The exclamation point within an equilateral triangle is intended to alert the user to the presence of important operating and maintenance (servicing) instructions in the literature accompanying the appliance.

SEE BOTTOM OF SET

## IMPORTANT SAFETY INSTRUCTIONS

1. Read these instructions.
2. Keep these instructions.
3. Heed all warnings.
4. Follow all instructions.
5. Do not use this apparatus near water.
6. Clean only with dry cloth.
7. Do not block any ventilation openings, install in accordance with the manufacturer's instructions.
8. Do not install near any heat sources such as radiators, heat registers, stoves, or other apparatus (including amplifiers) that produce heat.
9. Do not defeat the safety purpose of the polarized or grounding-type plug. A polarized plug has two blades with one wider than the other. A grounding type plug has two blades and a third grounding prong. The wide blade or the third prong are provided for your safety. If the provided plug does not fit into your outlet, consult an electrician for replacement of the obsolete outlet.
10. Protect the power cord from being walked on or pinched particularly at plugs, convenience receptacles, and the point where they exit from the apparatus.
11. Only use attachments/accessories specified by the manufacturer.
12. Unplug this apparatus during lightening storms or when unused for long periods of time.
13. Refer all servicing to qualified service personnel. Servicing is required when the apparatus has been damaged in any way, such as power-supply cord or plug is damaged, liquid has been spilled or objects have fallen into the apparatus, the apparatus has been exposed to rain or moisture, does not operate normally or has been dropped.
14. This appliance shall not be exposed to dripping or splashing water and that no object filled with liquid such as vases shall be placed on the apparatus.

## **ADDITIONAL SAFETY INSTRUCTIONS**

1. **Power Sources** - The appliance should be connected to a power supply only of the type described in the operating instructions or as marked on the appliance.
2. **Wall or Ceiling Mounting** - The appliance should not be mounted to a wall or ceiling.
3. **Object and Liquid Entry** - Care should be taken so that objects do not fall and liquids are not spilled into the enclosure through openings.
4. **Servicing** - The user should not attempt to service the appliance beyond that described in the operating instructions. All other servicing should be referred to qualified service personnel.

It is the intent of Lenoxx that this product be used in full compliance with the copyright laws of the United States and that prior permission be obtained from copyright owners whenever recording songs from the RADIO or CD's.

Do not apply oil or petroleum products or solvents to any part of this set.

### **CAUTION**

Use of controls or adjustments or performance of procedures other than those specified herein may result in hazardous radiation exposure.  
This compact disc player is classified as CLASS 1 LASER PRODUCT as stated on the bottom of the set.

# LOCATION OF CONTROLS

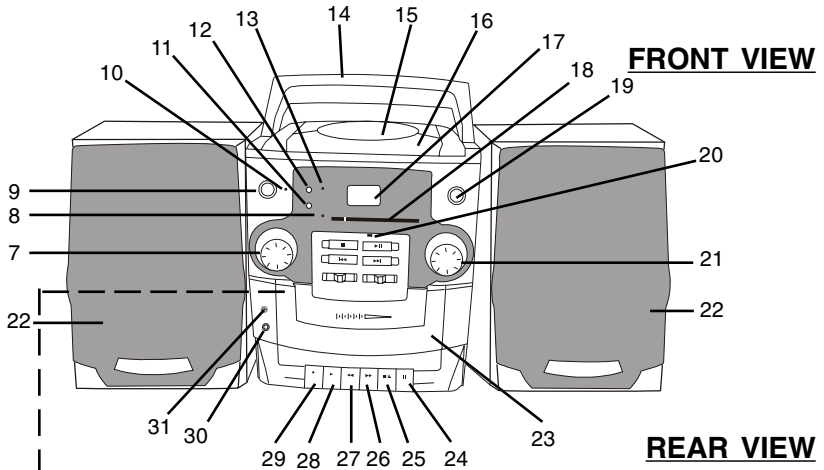

## CONTROL PANEL

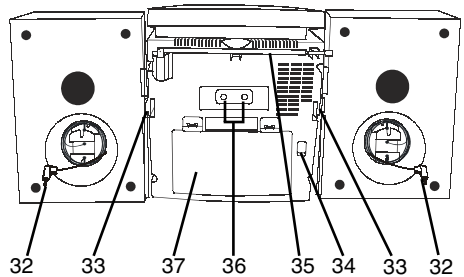
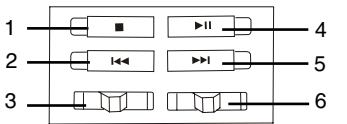

1. CD STOP BUTTON
2. CD BACKWARD SKIP/SEARCH BUTTON
3. FUNCTION SWITCH
4. CD PLAY/PAUSE BUTTON
5. CD FORWARD SKIP/SEARCH BUTTON
6. BAND SWITCH
7. VOLUME CONTROL
8. FM STEREO INDICATOR
9. POWER SWITCH
10. POWER/BATT. LAMP
11. CD RANDOM BUTTON
12. CD PROGRAM/REPEAT BUTTON
13. CD REPEAT LAMP
14. FOLDING HANDLE
15. CD DOOR
16. CD DOOR OPEN/CLOSE AREA
17. COMPACT DISC DISPLAY
18. AM/FM DIAL SCALE
19. BASS BOOST SWITCH

20. CD PLAY/PROGRAM LAMP
21. TUNING CONTROL
22. DETACHABLE SPEAKERS
23. CASSETTE DOOR
24. CASSETTE PAUSE BUTTON
25. CASSETTE STOP/EJECT BUTTON
26. CASSETTE FAST FORWARD BUTTON
27. CASSETTE REWIND BUTTON
28. CASSETTE PLAY BUTTON
29. CASSETTE RECORD BUTTON
30. STEREO PHONES JACK  
(headphones not included)
31. BUILT-IN CONDENSER MICROPHONE
32. SPEAKER PLUGS
33. DETACHABLE SPEAKER LOCKS
34. AC SOCKET
35. FM TELESCOPING ANTENNA
36. SPEAKER JACKS
37. BATTERY COMPARTMENT DOOR

# INTRODUCTION

Your new COMPACT DISC PLAYER WITH AM/FM STEREO CASSETTE RECORDER is a specially designed all solid state set which, with proper care, will give you years of trouble-free service. Please read these operating instructions carefully as they will help you obtain maximum performance from this set. Unpack the set carefully and place it on a level surface, away from sources of excessive heat, such as radiators.

## POWER SUPPLY- 2 WAY SYSTEM

This set is designed to be operated from two different power sources as listed below:

### A. DC OPERATION

This set runs on 8 size "D" batteries. For best performance, always use heavy duty alkaline batteries.

### TO INSTALL BATTERIES

1.Remove the BATTERY DOOR by gently pushing tabs downward and outward.

2.Install 8 size "D" batteries.

**NOTE:** The battery compartment has 2 levels, upper and lower. Be sure to install the batteries as per the sketch shown and the indication on the back of the set.

3.Replace the BATTERY DOOR.

**NOTE:** Old batteries may swell and leak. To avoid damage to your set, remove the batteries when the set is to be stored for long periods of time or if the batteries become exhausted (when the batteries become weak, the POWER/BATT. lamp will be dim; when the batteries are completely dead, the POWER/BATT. lamp will be off).

**NOTE:** To use your set on battery power, you **MUST** remove the AC power cord from **BOTH** the wall outlet **AND** the back of the set.

**NOTE:** Do not mix old and new batteries. Do not mix rechargeable (nickel cadmium) and regular carbon zinc or alkaline batteries. Installation of batteries should be done by an adult (for safety).

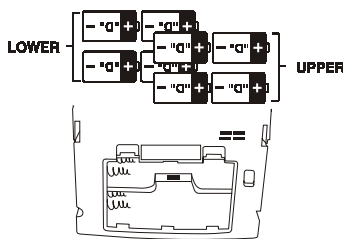

**NOTE:** The negative polarity (side) of battery touches the spring.

### BATTERY INDICATOR

The POWER lamp also shows you if your batteries are fresh. When this lamp gets dim, it is time to replace the batteries.

### B. AC OPERATION

Plug the AC power cord into the back of the set and insert the AC PLUG into 120 Volts AC 60Hz standard household outlet.

**NOTE:** This cord is polarized. This means either end of the cord will only fit **ONE** way into the socket or wall outlet. If it does not fit, do not force it, just reverse it and try again.

**NOTE:** If the AC power cord is plugged into the back of the set, the set will not work on batteries. To operate the set on batteries, remove the AC PLUG from the back of the set.

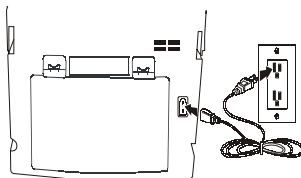

POLARIZED AC PLUG

## ATTACHING THE SPEAKERS

**NOTE:** The right and left speakers are **NOT** interchangeable. The right speaker fits **only** on the right side (as shown in FIG. 1). The left speaker fits **only** on the left side.

1. Bring the right speaker to the right side of the set.

2. Raise the right speaker box about 4 inches above the set. Align the tracks (rails).

3. Fit speaker over the side rails.

4. When speaker fits over the rails, lower the speaker as shown in FIG. 2, and make sure the tabs snap into the speaker box (locks in the back).

5. Repeat above steps 1 to 4 for the left speaker box.

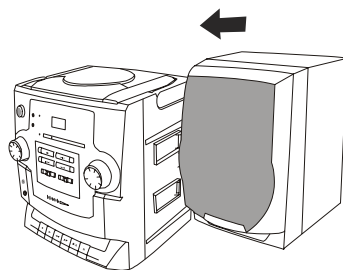

FIG. 1

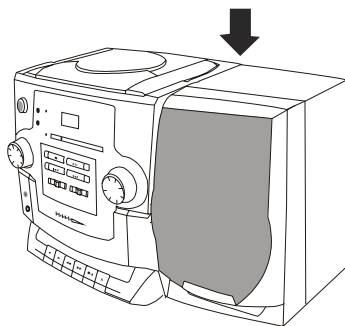

FIG. 2

6. Carefully unwind the speaker wire from behind each speaker box and plug the right plug into SPEAKER JACK R, also plug the left plug into SPEAKER JACK L (as shown in FIG. 3). Wrap the remaining wire behind each speaker box.

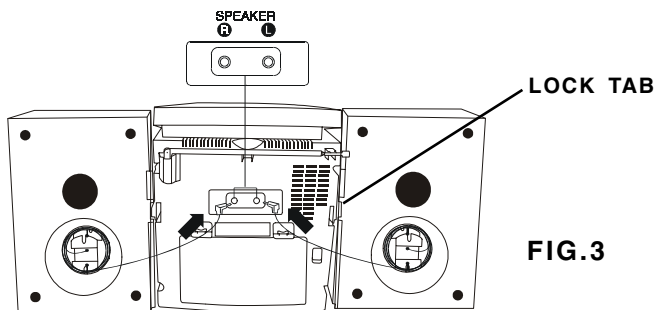

FIG. 3

**NOTE:** This set can be used with speaker boxes attached to the main set or separated, just make sure both speaker plugs are plugged into the jacks.

**To remove the speakers, press the lock tab and raise the speakers.**

## BASS BOOST SWITCH

This set has a BASS BOOST switch which allows you to hear more bass (low frequency) sounds. You may press it ON or OFF to your taste (Bass means low frequency sounds like a bass drum).

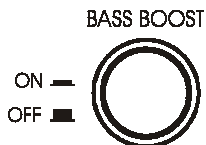

## STEREO HEADPHONE JACK

A STEREO PHONES jack has been provided on the front of the set so that you can listen to the set without disturbing others. To use this jack, plug in low impedance stereo headphones (not included) and adjust the VOLUME CONTROL to your taste. Special internal switches will turn off the set's speakers when you plug in the stereo headphones.

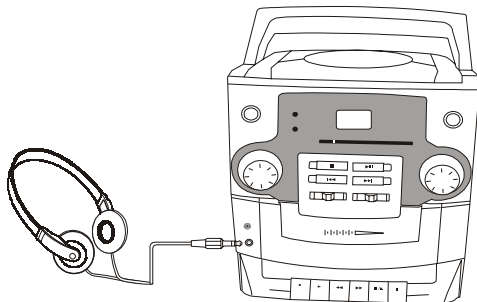

## TO PLAY THE RADIO

Make sure the speakers are connected (plugged into the jacks in the back of the set).

1. Press the POWER switch (the POWER/BATT. lamp will light).
2. Slide the FUNCTION switch to the RADIO position.
3. Select desired wave band (AM, FM or FM STEREO) with the BAND switch.
4. Tune to desired station with the TUNING CONTROL.
5. Gently turn this control back and forth until you get the strongest, clearest sound.
6. The built-in AM antenna and the FM Telescoping Antenna are directional. When receiving FM broadcasts, carefully extend the FM Telescoping Antenna to its full length. The strongest reception can be achieved by rotating the set or the FM Antenna.
7. Adjust the VOLUME CONTROL to your listening preference.
8. If you prefer more bass, press the BASS BOOST switch.

9. To turn off the radio, slide the FUNCTION switch to TAPE position. To shut the power off, press the POWER switch again, the POWER/BATT. lamp will go off.

**NOTE:** FM Stereo is weaker than FM (mono). If your FM stereo station is weak or you hear too much noise or hissing, try to adjust the FM Telescoping Antenna or slide the BAND switch from FM STEREO to FM.

# CD OPERATION

## HANDLING A DISC

Although built to withstand a certain amount of the effects from dust, soil and scratches, discs should be treated with the care normally according to conventional analog discs (records). Always protect a disc against scratches, soil and dust etc. We recommend that during non-use periods, the discs should be stored in their original cases.



HANDLE DISC AS SHOWN

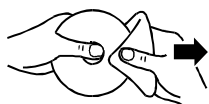
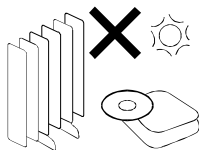

CLEAN FROM CENTER TO EDGE

Since any dirt, scratches or warping of the disc can cause skipping or intermittent sound or noise, bear in mind the following points:

- When holding the discs, take care not to touch the playing surface.
- Store the discs in their cases. Return them to their cases with the label surface facing up and push down lightly on the label surface.
- Do not place discs near a heating device or a place where the temperature is high or in dusty areas.
- Do not write on the label surface using a ballpoint pen and do not stick labels on the CD.
- Wipe away any fingerprints or dust on the playing surface of a disc using a soft cloth.

Bear in mind the following points when cleaning your discs:

- Always wipe from the inside toward the outside of the disc.
- Never in a circular motion.
- Do not use conventional record cleaners, anti-static agents, benzene, thinner or other solvents.

## PLAYING A CD (COMPACT DISC)

1. Press the POWER switch on and slide the FUNCTION switch to the CD position, the POWER/BATT. lamp will light and the DISPLAY will show 2 zeros "00".
2. Press the CD door OPEN/CLOSE area to open the CD door.
3. Insert a CD with the **LABEL** side facing **UP** (if the disc is **upside down** or **damaged**, the DISPLAY will show 2 zeros "00" and then "no").
4. Close the CD door by gently pushing the door down.
5. The DISPLAY will show 2 zeros "00" and then the total number of tracks (songs) on the CD.
6. To start the music, press the CD PLAY/PAUSE button (wait a few seconds for music to start). The first track number "01" will appear in the Display, the PLAY/PROGRAM lamp will light and the disc will start playing.
7. Adjust the VOLUME CONTROL to your taste. For extra bass sound, press the BASS BOOST switch down.
8. To pause the music - if the phone rings or other reasons, press the PLAY/PAUSE button, the track number will flash to remind you that you are in pause mode.
9. To resume the music from pause, press the PLAY/PAUSE button again. The track number will be steady on (**not flashing**).
10. To stop playing music, press the CD STOP button.
11. To turn off the CD, slide the FUNCTION switch to TAPE position. To shut the power off, press the POWER switch again, and the POWER/BATT. lamp will go off.

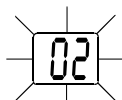



# CD OPERATION

## REMOVING A DISC

1. Make sure the CD is not playing before removing the disc. If it is, press the CD STOP button.
2. Press the CD door OPEN/CLOSE area to open the CD door.
3. Gently remove the disc.
4. Close the CD door by gently pushing the door down.
5. Replace the disc in its original case.

**NOTE:** Never press the CD door down during play, this may cause malfunction or damage to the disc. Always stop the CD player by pressing the CD STOP button before you take the disc out of the compartment.

**NOTE:** If you hit or move the set during play, the music will stop for a second or two and then start again. This is normal operation for all portable CD players.

## SKIPPING TRACKS (SEARCH)

1. This function enables you to find the beginning of any desired track during play. If the CD FORWARD SKIP/SEARCH ( ►► ) button is pressed once or repeatedly, the **NEXT TRACK** or one of the following tracks will be selected. The DISPLAY will show the track or song number.
2. If the CD BACKWARD SKIP/SEARCH ( ◀◀ ) button is pressed twice or more in rapid succession, play will go **BACK** one track per press.
3. When the set is in the pause mode, it is also possible to select the beginning of a certain track by using the CD FORWARD SKIP/SEARCH( ►► ) button and CD BACK SKIP/SEARCH( ◀◀ ) button to reach the desired track. After selection, press PLAY.
4. During play, press and **HOLD** the CD FORWARD SKIP/SEARCH( ►► ) button to search forward at a high speed for a particular point of a song. Press and **HOLD** the CD BACK SKIP/SEARCH( ◀◀ ) button to search backward. Release the button to resume normal play when the point is found.

## REPEAT PLAY - SINGLE SONG

To repeat the **SAME** song over and over again, do the following:

1. When the CD is playing, press the REPEAT/PROGRAM button once.
2. The REPEAT lamp will be steady on. The song currently playing will play over and over, till you press Stop.
3. To stop the repeat function, press the REPEAT/PROGRAM button twice.



REPEAT LAMP ON

## REPEAT PLAY - ALL SONGS

To repeat play **ALL SONGS** on a disc and then play them again and again, do the following for non stop music.

1. When the CD is playing, press REPEAT/PROGRAM button twice.
2. The REPEAT lamp will be flashing. All the songs on the CD will play in order and then start all over again.
3. To stop the repeat function, press the REPEAT/PROGRAM button once.



REPEAT LAMP FLASHING

# CD OPERATION

## RANDOM PLAY

1. Press RANDOM button either in stop mode or normal play mode, the set will play all of the songs in random order. The DISPLAY will show some moving symbols like “ $\square \square \dots \square \square \dots \square \square$ ” every 5 seconds.
2. Press the FORWARD SKIP/SEARCH  $\blacktriangleright$  button to skip to the next random song.
3. To resume normal play, press RANDOM button again.

## PROGRAMMED MEMORY PLAY

Up to 16 tracks can be programmed for disc play in the order you like. Programming can only be done during **STOP** mode.

**NOTE:** Under some conditions you may be able to program more than 16 tracks.

## PROGRAMMED (MEMORY) PLAYBACK

1. During **STOP** mode, press REPEAT/PROGRAM button.
2. The Display will show “ $P0$ ”.
3. Press the SKIP/SEARCH buttons either  $\blacktriangleleft$  or  $\blacktriangleright$  until the desired track shows on the DISPLAY. The PLAY/PROGRAM lamp will flash.
4. Press the REPEAT/PROGRAM button. The Display will show “ $P1$ ” and the PLAY/PROGRAM lamp will flash.
5. Repeat steps 3 and 4 until all the desired tracks are programmed.

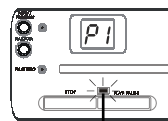

PLAY/PROGRAM  
LAMP FLASHING

**NOTE:** For programmed tracks from 11th to 16th, the display will separately show “ $P0$ ”, “ $Pb$ ”, “ $Pc$ ”, “ $Pd$ ”, “ $Pe$ ” and “ $Pf$ ”.

6. When you finished programming, press the CD PLAY/PAUSE button.
7. All songs will play in the order you programmed.
8. The DISPLAY will show the track number being played, and the PLAY/PROGRAM lamp will remain flashing during programmed play.
9. If in middle of play, you want to hear the next programmed song, press the FORWARD SKIP/SEARCH  $\blacktriangleright$  button.
10. When all the songs have finished playing, the set will stop. The PLAY/PROGRAM lamp turns off.
11. To turn off the power, remember to press POWER switch again, the POWER/BATT. lamp will go off.

**NOTE:** Programming can **only** be done when the CD is in the **STOP** mode. (CD is in the set, FUNCTION switch is in the CD position and DISPLAY shows the total CD tracks.)

### EXAMPLE: To program track 4 to play first.

When CD has stopped,

- Press REPEAT/PROGRAM button, “ $P0$ ” will show and PLAY/PROGRAM lamp will flash.
- Press the FORWARD SKIP/SEARCH button till track 4 appears.
- The DISPLAY will show “ $04$ ” and PLAY/PROGRAM lamp will flash.
- Press REPEAT/PROGRAM button, “ $P1$ ” will show and PLAY/PROGRAM lamp will flash.
- Press PLAY BUTTON.
- Track 4 will play first.

**NOTE:** The programmed memory will be cleared if CD door is opened or power is turned off.

---

# CASSETTE OPERATION

---

**NOTE:** All of the tape buttons (except the CASSETTE PAUSE button and CASSETTE STOP/EJECT button) operate in the same fashion. To activate a feature, you press the button all the way down so that it stays in its depressed position when you release it. To deactivate the feature, press CASSETTE STOP/EJECT button.

## FAST FORWARD AND REWIND

For fast forward or rewinding of the tape, press the CASSETTE FAST FORWARD button or CASSETTE REWIND button.

## PAUSE

The CASSETTE PAUSE button is used to edit commercials or in case recording is temporarily interrupted. Since the deck motor is still running while the PAUSE button is depressed, this pause feature should be used for a short time only.

## AUTOMATIC STOP

This set has a built-in automatic stop feature and the tape mechanism will stop playing or recording and shut itself off when it has reached the end of the tape.

## MANUAL STOP

The tape player can be stopped manually by pressing the Cassette STOP/EJECT button.

# CASSETTES

## CASSETTE TAPE SELECTION

The quality and condition of the cassette tapes you use will have a direct effect on the performance of this set.

Low quality tapes tend to be broken and stretched and a broken tape can easily become entangled in the drive mechanism, causing major damage. Stretched tapes will run at uneven speeds and will distort anything recorded on them.

- Use only well-known brands of tapes.
- Use of C-120 (120 minutes) cassette is not recommended. The extreme thinness of this tape may result in breakage or other failures.
- This set is not designed for CrO<sub>2</sub>, Fe-Cr or METAL tape use. Therefore, be sure to use name brand normal cassette tapes. You may use the above (special) tapes, but the best sound quality is from **normal bias** tapes.

## CASSETTE TAPE FOR RECORDING

Generally, a fresh blank tape is most desirable for use when recording. A tape with previously recorded information can also be used since this set erases the tape in the recording process, providing the Record Interlock defeat tabs are in place. For more information on these tabs, see PROTECTING CASSETTE TAPE AGAINST ERASURE on page 15.

## IMPORTANT NOTES CONCERNING CASSETTE TAPES

1. After a period of time, especially when inexpensive brands of tapes are used, the sound during playback may become “muffled” or, in extreme cases, almost inaudible.

This is most frequently NOT A FAULT OF THE SET ITSELF but merely a deposit of oxide and other dirt on the tape heads.

The easiest way to solve this problem is by using a head-cleaning cassette. Follow the instructions provided with the cleaner carefully.

The tape head is a delicate precision component and serious damage will result if you attempt to scrape dirt away with a sharp tool.

2. Other common causes of trouble are:

(a) Tapes jamming - leading to uneven speed during playback.

(b) Tapes tangling - where the tape wraps itself around vital parts of the mechanism.

To reduce the chances of these problems occurring, you should take the following precautions:

- (1) Check that there are no loose layers of tape visible through the cassette center window (see FIG. 1). Tighten these loose layers of tape using a pencil before inserting the cassette into the set (see FIG. 2).
- (2) If the cassette feels tight while performing the operation as shown in FIG. 2, the tape may be jamming due to “ridges” in the winding of the tape (visible through the center window). These may be removed in most cases by fast winding the cassette from one end to the other and back again, or the tape may be permanently damaged. Do not play damaged or worn out tapes, as this may cause your set to break.

FIG. 1

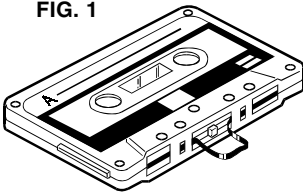
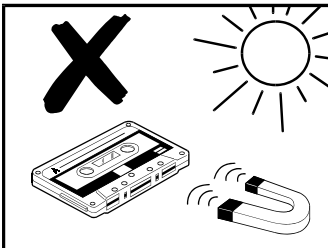
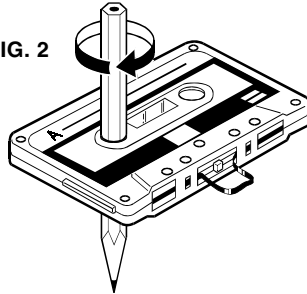

FIG. 2



### NOTES FOR STORING CASSETTE TAPES

1. Do not put a cassette near a magnetic field, such as a TV, or speaker. Magnetic fields may reduce the tape sensitivity or even erase the recording.
2. Do not store cassette for any length of time in a hot, moist or dusty place.

# TO PLAY A CASSETTE TAPE

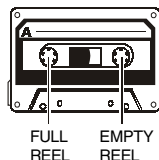
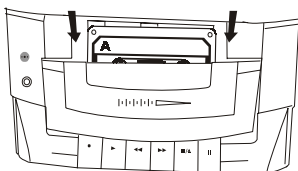
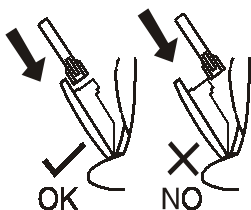

1. Open the CASSETTE DOOR by pressing the CASSETTE STOP/EJECT button (in some cases, you may have to press the CASSETTE STOP/EJECT button twice since this button has combined functions).
2. Insert the cassette tape, with the exposed tape facing downwards, into the tracks in the CASSETTE DOOR with the full reel on the left side, make sure the tape inside is not slack or loosely wound. If it is, insert a pencil into the reel and turn until the tape is wound up (see Page 11).
3. Close the CASSETTE DOOR.
4. Make sure the FUNCTION switch is in the TAPE position and the POWER switch is ON (pressed down), the POWER/BATT. lamp will light.
5. Press the CASSETTE PLAY button. The cassette tape will play till it reaches the end and then stop.

**NOTE: If the CASSETTE PLAY button does not stay down, your tape may have reached the end of the tape, reverse the tape or press Rewind.**

6. Adjust the VOLUME CONTROL and BASS BOOST switch to your listening preference.
7. To stop the tape manually, press the CASSETTE STOP/EJECT button.
8. To remove the tape, press the CASSETTE STOP/EJECT button again and the CASSETTE DOOR will open.

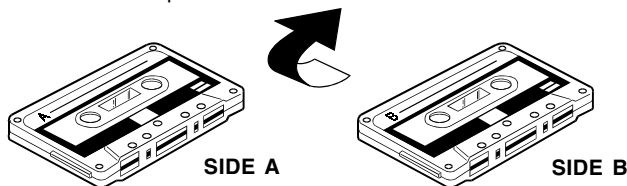

To listen to the other side of the tape:

Remove the cassette tape, reverse it and re-insert into cassette compartment to play the other side of the cassette tape.

To shut the power off, press the POWER switch again, the POWER/BATT. lamp will go off.

## AUTOMATIC LEVEL CONTROL (ALC)

This set has the latest Automatic Level Control circuitry, therefore, it is not necessary to adjust the VOLUME CONTROL when recording. This circuit automatically records at the correct level and prevents over loading.

**NOTE:** While recording, you may adjust the VOLUME CONTROL or BASS BOOST switch as you desire without affecting the recording operation.

## TO RECORD FROM THE BUILT-IN AM/FM RADIO

1. Follow the instructions **TO PLAY THE RADIO** (see page 6).
2. Make sure the FUNCTION switch is in the RADIO position, and POWER switch is ON (in depressed position).
3. Load the blank cassette tape with full reel on the left side.
4. Locate the portion of the tape where you desire to start recording by using the Rewind feature (or Fast Forward) or start at the beginning of the tape.
5. Tune into the station you want to record, press the CASSETTE RECORD button and CASSETTE PLAY button simultaneously. Both buttons should remain in their depressed positions when released. If the RECORD button cannot go down, see page 15. Do not force this button down. Or if button does not stay down, your tape may have reached the end of the tape, reverse it so that full reel is on the left side.
6. You are now recording from the Built-in Radio and the recording process will automatically stop at the end of the tape.
7. To stop the recording manually, press the CASSETTE STOP/EJECT button.
8. Slide the FUNCTION switch to TAPE to turn off the radio. Press the POWER switch to shut off the power, and the POWER/BATT. lamp will go off.

**NOTE:** When you want to play the cassette tape after recording, slide the FUNCTION switch to TAPE position, press the CASSETTE REWIND button, and then press the CASSETTE PLAY button. Adjust the VOLUME CONTROL and BASS BOOST switch to your taste.

## TO RECORD FROM THE BUILT-IN MICROPHONE

1. Load a blank cassette tape (full reel on left side).
2. Make sure the FUNCTION switch is in the TAPE position, and the POWER switch in ON position.
3. Press the CASSETTE RECORD button and CASSETTE PLAY button at the same time. Both buttons should remain in their down positions when released. If the RECORD button cannot go down, see page 15. Do not force this button down. Or if it does not stay down, your tape may have reached the end of the tape, reverse it so that full reel is on the left side.
4. When you talk in front of the set, your voice will be recorded. You are now recording using the BUILT-IN CONDENSER MICROPHONE and the recording process will automatically stop at the end of the tape.
5. To stop the recording manually, press the CASSETTE STOP/EJECT button.
6. To hear what you recorded, press the CASSETTE REWIND button and CASSETTE PLAY button.
7. To shut off the set, press the CASSETTE STOP/EJECT button and the POWER switch. The POWER/BATT. lamp will go off.

## TO RECORD FROM COMPACT DISC

1. Load the cassette tape into the Cassette Compartment (full reel on the left side).
2. Load the CD and close the CD door.
3. Set the FUNCTION switch to the CD position and press the POWER switch to ON (depressed position), the POWER/BATT. lamp will light.
4. Press the CASSETTE PAUSE button.
5. Press the CASSETTE RECORD and PLAY buttons for record standby.  
**NOTE:** When pressing the CASSETTE RECORD button, the CASSETTE PLAY button will automatically go down (If the buttons do not go down, reverse the tape or check record lever interlock on Page 15).
6. Start the CD playing by pressing the CD PLAY/PAUSE button.
7. Press (and release) the CASSETTE PAUSE button when you wish to start recording.
8. You are now recording the CD music onto your cassette tape.
9. Press the CASSETTE STOP/EJECT button to stop recording.
10. The recording will stop when the tape has reached the end and the CASSETTE RECORD and PLAY buttons will pop up.
11. To hear what you recorded, slide the FUNCTION switch to the TAPE position, press REWIND and PLAY buttons.
12. To shut off the set, press the CASSETTE STOP/EJECT button, and then press the POWER switch (pop-up position), the POWER/BATT. lamp will go off.

## TO ERASE A TAPE

Simply record any new song, the old song will be erased automatically.

**NOTE:** If you cannot press the CASSETTE RECORD button down, see record lever Interlock information on Page 15, or your tape may have reached the end. Remove the tape and flip it over to the other side or press REWIND button.

## CAUTION:

- The automatic stop mechanism may not operate during playback of tape when the set is using batteries and the batteries are weak.
- Disconnect the AC power cord plug from the AC outlet if the set is not going to be used for a long period of time (2 weeks or more). Also remove the batteries.
- Do not leave any tape buttons down when the set is not in use, or else the pinch roller could be damaged.
- Remember when inserting tapes, the full reel must be on the **left** side.
- If the CASSETTE PLAY button pops up, your tape has reached the end, reverse the tape or press the REWIND button.

# RECORD LEVER INTERLOCK

## PROTECTING CASSETTE TAPE AGAINST ERASURE

All cassette tapes are provided with tabs which, when in place, allow tape erasure to be performed. If the tabs are **removed** then the tape **CANNOT** be erased or recorded on and the CASSETTE RECORD button cannot be pressed.

To protect the **A** (or **1**) side for cassette tape, break off the **A** side tab with a screwdriver.

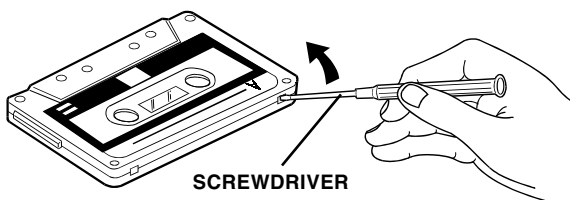

Break the small tab to prevent erasing or recording

Follow same procedure for **B** (or **2**) side.

**NOTE:** Music tapes you buy from a store have these tabs removed to prevent accidental erasure.

The tape can be re-recorded or erased, if required, by covering the tab holes with plastic tape.

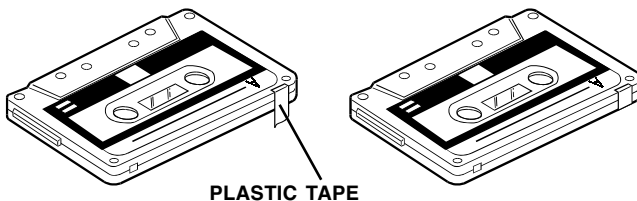

**NOTE:** If the RECORD button will not go down, the tabs above are probably missing - Also check if the tape has reached the end.



# CLEANING THE TAPE HEADS

We suggest using a special cleaning tape cassette (not included) (available in most music and Hi-Fi stores). But if you do not have one, you may follow the instructions below.

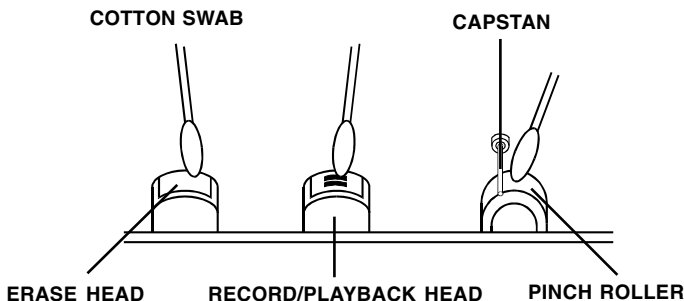

When the heads, capstan and pinch roller become dirty, this may result in muffled, distorted or reduced sound during playback and may even result in tape jams.

Remove the cassette tape and clean with a cotton swab moistened with commercially sold head/pinch roller cleaner or alcohol. Wait approximately 10 seconds for the alcohol or cleaning fluid to dry before using.

## HOW TO GET THE BEST OUT OF YOUR SET

**AM RECEPTION** - You may find that you can improve the reception of your favorite station by rotating the set a small amount.

**FM RECEPTION** - You may find that you can improve the reception of your favorite station by collapsing the telescoping antenna a small amount, rotating or extending it to the full length.

**RECORD BUTTON** - If you find that you cannot press this button down, check the Record Interlock defeat tabs on the cassette (see page 15), or the tape may be at the end, rewind the tape or reverse it.

**TAPE HEADS** - The tape heads should be cleaned periodically with a special cleaning tape (available in music and Hi-Fi stores) to remove the particles of brown oxide coating from the tapes that collected on these heads. These particles fill the gap in the heads and degrade performance.

# TROUBLE SHOOTING CHECK LIST & HELPFUL HINTS

SHOULD YOUR SET HAVE A PROBLEM, CHECK THE FOLLOWING:

PROBLEM	CHECK THE FOLLOWING
Set does not work on AC	Does the AC outlet being used actually have AC power? Is the power cord plugged into the back of the set? Is POWER/BATT. lamp ON?
Set does not work on batteries	Are the batteries fresh and properly installed? Is power cord connected? Remove power cord from both AC Socket and outlet. Is the POWER/BATT. lamp ON?
Sound is distorted, the POWER/BATT. lamp is dim	The batteries are weak or not installed correctly. Replace batteries and/or check the polarity.
No sound	Are the speakers plugged in? Check the back of the set and see page 5. Is the VOLUME CONTROL at MIN? Is headphone in jack? Is play off? Are batteries fresh?
AM, FM, FM Stereo reception weak	Rotate the unit to improve AM reception. For FM reception, extend and adjust the FM Telescoping Antenna. FM Stereo is weaker than FM, slide the switch to FM if station is weak.
Poor quality recording or playback of cassette tapes	Clean the tape heads using a special cleaning tape cassette (not included) (available at most music and Hi-Fi stores). If you do not have a cleaning tape, please see page 16.
The CASSETTE RECORD button will not stay down	Does the cassette tape you are using still have its tabs on the rear surface? See details on Record Lever Interlock on page 15.
The CASSETTE PLAY button or CASSETTE RECORD button will not stay down	The tape has ended. Remove tape, flip it over to the other side and then reinsert and press Play, or rewind it.
NORMAL BATTERY LIFE USING ALKALINE BATTERIES IS ABOUT 8 HOURS OF CASSETTE PLAYING TIME.	

# CD TROUBLE SHOOTING GUIDE

PROBLEM	POSSIBLE CAUSE AND REMEDY
CD does not rotate	<p>Is AC power cord plugged into outlet? Does outlet have power? Check outlet with a lamp or other appliance.</p> <p>Make sure the FUNCTION switch is in CD position. If using the set on batteries - make sure you unplug the AC cord from the back of the set and outlet.</p> <p>- Also check if batteries are fresh.</p> <p>(The AC SOCKET in the back of the set has a switch which shuts off battery power if cord is plugged into the back of the set).</p>
CD does not play	<p>If the Display shows “no”. This means the CD disc is upside down. Open the door, remove the CD, flip it over and insert correctly. The printed side up.</p> <ol style="list-style-type: none"> <li>1. Is the lens very dirty? (Gently clean lens with a soft cloth or CD cleaner disc available at most Hi-Fi stores.)</li> <li>2. Is POWER/BATT. lamp ON?</li> <li>3. Is the FUNCTION switch in CD position?</li> <li>4. Is the track number flashing? (press PLAY button) The track number will flash in pause and be steady on during play.</li> </ol>
Disc skips parts of songs	<p>Disc has a defect. Try cleaning the disc with a clean rag or disc cleaner. If this does not help, the disc may be damaged.</p> <p>Is the lens very dirty? Gently clean the lens.</p>
Speakers have no sound	<ol style="list-style-type: none"> <li>1. Are the speakers plugged in? Check the back of the set and see page 5.</li> <li>2. Is VOLUME CONTROL at MIN? Adjust the VOLUME CONTROL.</li> <li>3. Is headphone in jack? Remove headphones to power speakers.</li> <li>4. Make sure AC cord is plugged in or unplugged from back of set if using batteries.</li> <li>5. Make sure batteries are fresh.</li> </ol>

**NOTE:** The CD player and the cassette decks are fitted with self-lubricating bearings which must not be oiled or greased.

## TO CLEAN THE CD PLAYER

A chamois soft cloth very slightly moistened with water is sufficient for cleaning the housing of the set and the enclosures.

**NOTE:** Your CD player may not play when bringing it from a cold place (outdoors) to a warm place (indoors). Because of large temperature differences, condensation may have formed on the lens of the laser. This will disappear after some time (when the mechanism warms up).

# SPECIFICATIONS

## GENERAL DESCRIPTION

Power source: AC 120V, 60Hz, 15 Watts  
DC 12V (8 size "D" batteries)  
(we recommend alkaline batteries for longer life)

Speakers: 4" 4 ohm

Output Power: 3 Watts / channel

Dimensions:	MAIN SET	SPEAKER
Width :	8 1/4"	6 3/8"
Depth :	6 7/8"	7 1/4"
Height :	9"	9"
Weight :	5.8 lbs (without batteries)	2.27 lbs

## TAPE RECORDER SECTION

Tape: Standard normal bias cassette tape

Frequency response: 70 Hz - 10 kHz

## RADIO SECTION

Frequency range: FM: 88 - 108 MHz  
AM: 530 - 1700 kHz

## CD SECTION

Plays disc type: Any normal music CD

Laser wave length: 760 - 800 NM

Tracking method: 3 - spot error detection 3.86mm lens

Frequency response: 50 Hz - 15 kHz +1/-2 dB

**NOTE:** This CD player will only play **NORMAL** music CDs (or CD-R CDs).  
This set will not play **CDRW** encoded discs.

LENOXX reserves the right to make design and specification changes for product improvement.

### PROTECT YOUR FINE FURNITURE!

WE RECOMMEND A CLOTH OR OTHER PROTECTIVE MATERIAL BE PLACED UNDER THE SET WHEN PLACING IT ON SURFACE WITH A NATURAL OR LACQUER FINISH.

## For customer service

**Dial 1-800-315-5885** (MONDAY - THURSDAY 9:00 AM - 5:00 PM, FRIDAY 9:00 AM - 1:00 PM EST)

**or Visit Our Website:** <http://www.lenoxx.com>

© 2002 LENOXX ELECTRONICS CORP.  
2 GERMAK DRIVE  
CARTERET, N.J. 07008  
<http://www.lenoxx.com>

MADE & PRINTED IN CHINA