

COMPACT DISC PLAYER

DP-770

INSTRUCTION MANUAL

TRIO

TRIO-KENWOOD CORPORATION

©PRINTED IN JAPAN B50-5969-00(T)(T)
86/12 11 10 9 8 7 6 5 4 3 2 1 85/12 11 10 9





TRIO KENWOOD Corp. certifies this equipment conforms to DHHS Regulations NO. 21 CFR 1040.10, Chapter I, Subchapter J.

CAUTION: Use of controls or adjustments or performance of procedures other than those specified herein may result in hazardous radiation exposure.

TRIO KENWOOD CORPORATION

SHIONOGI SHIBUYA BUILDING
17-5, 2-CHOME, SHIBUYA, SHIBUYA-KU, TOKYO,
JAPAN

<p>CAUTION RISK OF ELECTRIC SHOCK DO NOT OPEN</p>	<p>CAUTION: TO REDUCE THE RISK OF ELECTRIC SHOCK, DO NOT REMOVE COVER (OR BACK). NO USER-SERVICEABLE PARTS INSIDE. REFER SERVICING TO QUALIFIED SERVICE PERSONNEL.</p>
	<p>The lightning flash with arrowhead symbol, within an equilateral triangle, is intended to alert the user to the presence of uninsulated "dangerous voltage" within the product's enclosure; that may be of sufficient magnitude to constitute a risk of electric shock to persons.</p>
	<p>The exclamation point within an equilateral triangle is intended to alert the user to the presence of important operating and maintenance (servicing) instructions in the literature accompanying the appliance.</p>

Introduction

The purpose of this manual is to acquaint you with the operating features of your new unit. You will notice that in every detail of planning, engineering, styling, operating convenience, and adaptability, we have sought to anticipate your needs and desires.

We suggest that you read this manual carefully. Knowing how to set up your unit to the best advantage will enhance your listening pleasure right from the start. You will also become aware of the ease with which you can adjust your unit to meet your special requirements.

For your records

Record the serial number, found on the back of the unit, in the spaces designated on the warranty card, and in the space provided below. Refer to the model and serial numbers whenever you call upon your dealer for information or service on this product.

Model _____ Serial number _____

After unpacking

After unpacking, we recommend that you inspect the unit for any possible shipping damage. If your unit is damaged or fails to operate, notify your dealer immediately. If your unit was shipped to you directly, notify the shipping company without delay. Only the consignee (the person or company receiving the unit) can file a claim against the carrier for shipping damage. We recommend that you retain the original carton and packing materials to prevent any damage should you transport or ship your unit in the future.

WARNING:

TO PREVENT FIRE OR SHOCK HAZARD, DO NOT EXPOSE THIS APPLIANCE TO RAIN OR MOISTURE.

AC voltage selection

This unit operates on 120 volts or 220-240 volts AC. The AC voltage selector switch on the rear panel is set to the voltage that prevails in the area to which the unit is shipped. Before connecting the power cord to your AC outlet, make sure that the setting position of this switch matches your line voltage. If not, it must be set to your voltage in accordance with the following direction.

Note:

Our warranty does not cover damage caused by excessive line voltage due to improper setting of the AC voltage selector switch.

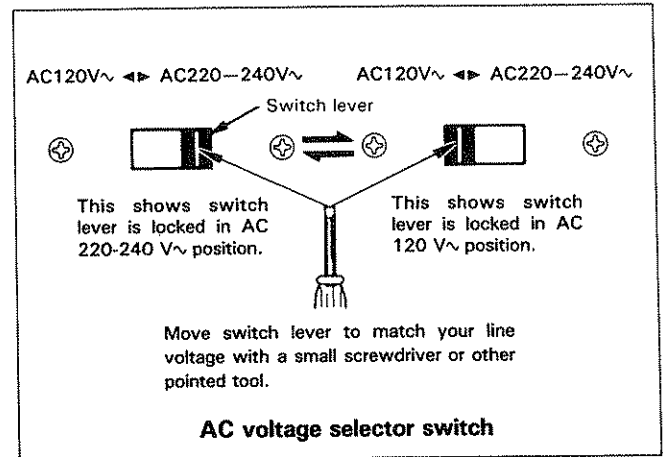

For United Kingdom

The mains plug must be removed from the wall socket prior to any internal examination.

Important

The wires in this mains lead are coloured in accordance with the following code:

Blue Neutral
Brown Live

The wires in this mains lead must be connected to the terminals in the plug as follows:

Wire colour	Plug terminal marking
Blue	N or Black
Brown	L or Red

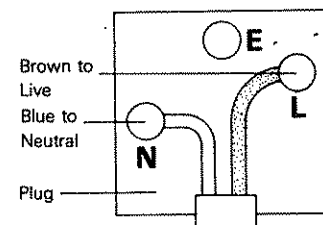

Notes:

- 1) If a 13-amp plug is used, this must be fitted with a 5-amp fuse.
- 2) If a 3-pin plug with earthing contact is used, no wire must be connected to the E terminal.

Before operation

Transportation screw

Before using the unit, remove the transportation screw by turning it counterclockwise using a coin as shown in the diagram. Save the screw as it should be reattached if the player is ever moved or shipped.

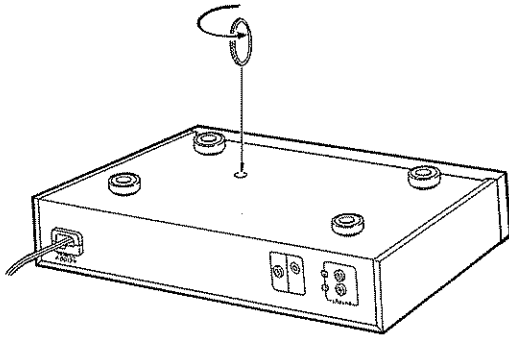

Notes on installation

Do not place the unit in a place which is exposed to direct sunlight, near a heating appliance, etc.

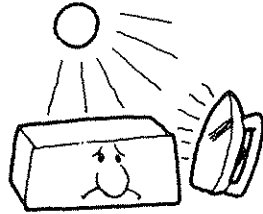

Do not place a vase containing water, makeup, etc. on the unit. Do not use in a humid place.

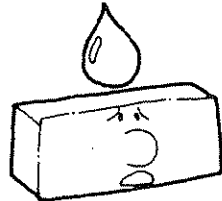

To maintain good ventilation, place the unit at least 10 cm away from the walls.



Choose a location that is relatively free from vibration or excessive dust.

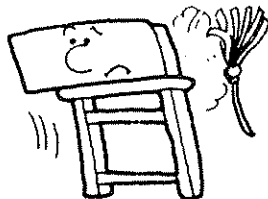

Keep the unit away from a source of magnetic fields such as TV sets, motorized toys, etc.

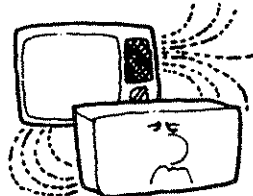

Safety precautions

Never remove the case. If the internal parts are touched accidentally, a serious electric shock might occur.

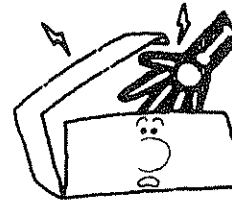

Never touch internal parts.

Touching the power plug when your hands are wet may result in a serious electric shock.

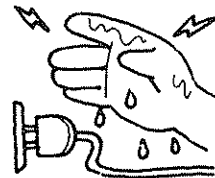

Never touch with wet hands.

Never pull, bend or extend the power cord. This could damage the power cord, resulting in a broken cord or short-circuit.

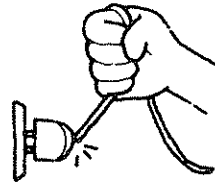

Always grasp the plug.

In case of abnormal smell

If an abnormal smell or smoke is detected, immediately turn the power OFF and pull out the power cord. Contact your dealer or nearest Service Station.

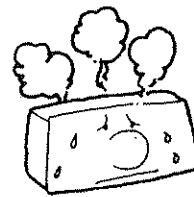

Cleaning

Do not use volatile solvents such as alcohol, paint thinner, gasoline, benzene, etc. to clean the cabinet. Use a silicone cloth or a clean dry cloth.

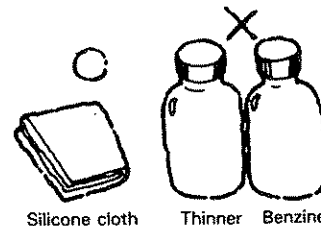

Silicone cloth

Thinner

Benzene

System connections

- Make system connections with the power turned off.

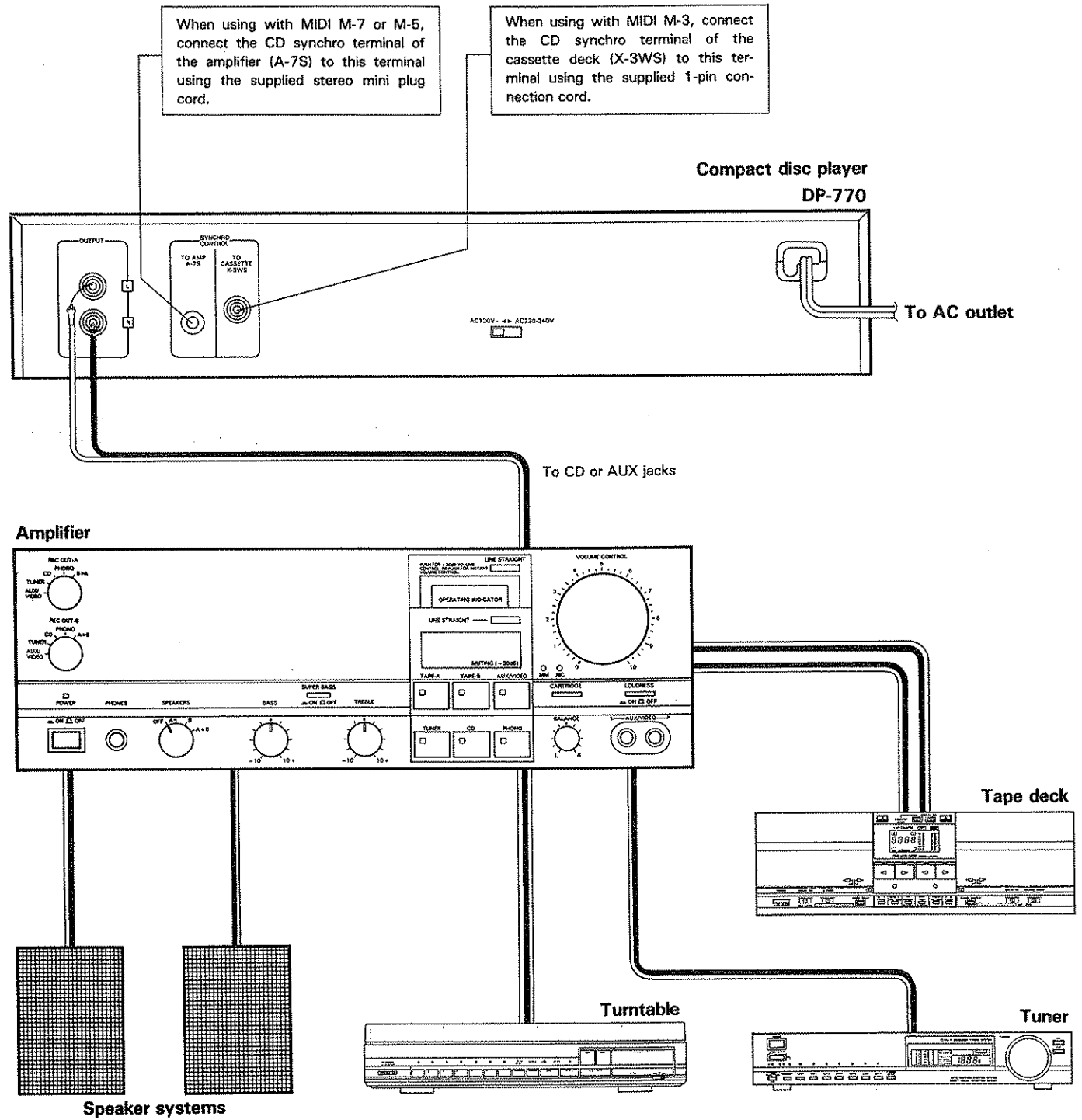

Power cord connection

Connect the power cord to a convenient AC outlet.

Connection to the amplifier

Connect the output jacks (OUTPUT) to the right and left CD, TUNER, TAPE IN or AUX jacks of the amplifier.

Note:

Do not connect the output jacks to the PHONO jacks of the amplifier.

Controls indicators

Numbers in circles correspond to the diagram, abbreviations in brackets correspond to front panel indications.

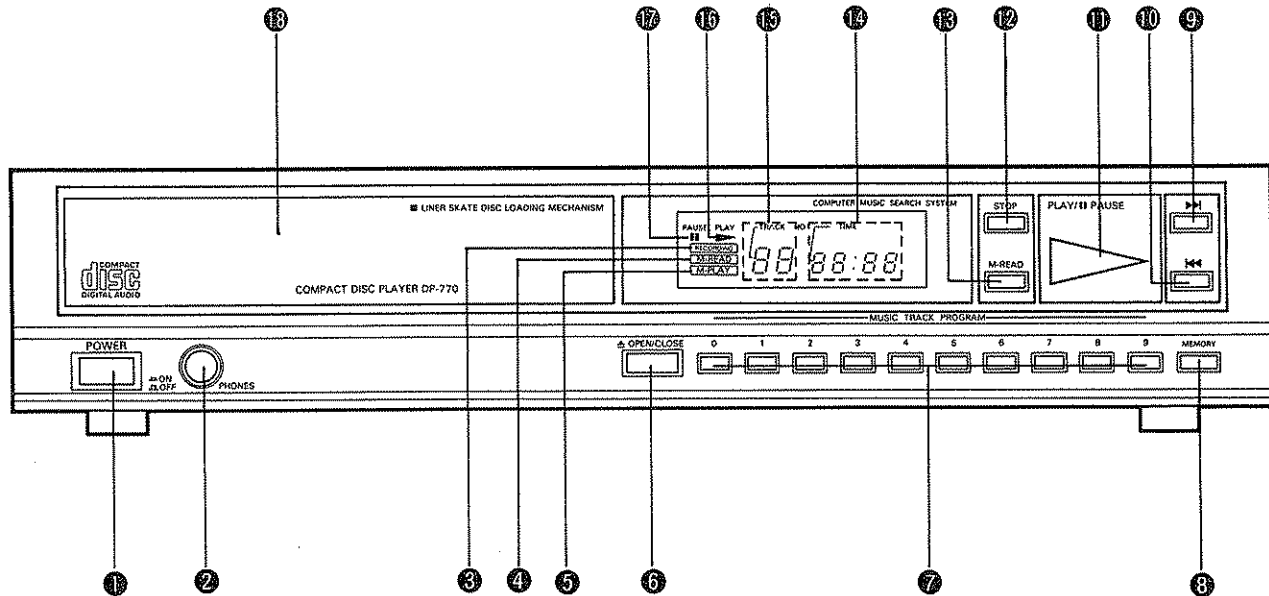

① POWER switch

Press once to turn power on and again to turn it off.

② PHONES (Headphones) jack

Connect headphones to this jack for private listening.

③ RECORDING indicator

Lights when the unit enters the system to synchro record mode.

④ M-READ (Memory Read) indicator

Lights when the M-READ key is pressed.

⑤ M-PLAY (Memory Play) indicator

Lights when the selection is memorized.

⑥ OPEN/CLOSE switch

Press to open or close the disc tray.

⑦ MUSIC TRACK PROGRAM keys

Use these keys to input Track No. for tune selection or memory.

⑧ MEMORY key

Use this to memorize the desired selection.

⑨ ►► Forward search key

Press to increase the Track No. A continuous press of this key will fast forward the pickup.

⑩ ◀◀ Backward search key

Press to reverse the pickup to the beginning of a tune you are listening to. A continuous press of this key will further reverse the Track.

⑪ PLAY/|| PAUSE key

Press once to enter the play mode. Press again to set to the pause mode.

⑫ STOP key

Press this key to stop play. When pressed while a selection is being memorized, the memory is erased.

⑬ M-READ (Memory read) key

Press this key to confirm a memorized selection.

⑭ TIME indicator

- Displays total playing time of the disc when the player is in the stop mode.
- Displays elapsed playing time in minutes and seconds when the player is in the play mode.
- Displays total playing time of a store program when the player is in the stop mode.

⑮ TRACK NO. indicator

Displays Track No.

⑯ PLAY indicator

Lights in the play mode.

⑰ PAUSE indicator

Lights in the pause mode.

⑱ Disc tray

Load a compact disc into this tray.

Operating instructions

How to load a compact disc

Disc tray

Press the OPEN/CLOSE switch to open/close the disc tray. Place the disc in the tray with the label facing up.

Notes:

1. If the disc is placed with the label facing down, sound will not be produced.
2. Do not place anything but a disc.

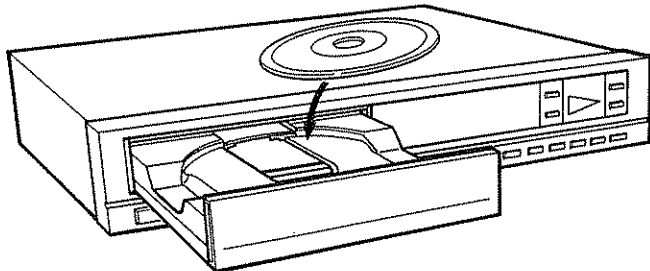

Manual playback

To play a disc

1. Turn the POWER switch ON.
 2. Press the OPEN/CLOSE switch to open the disc tray.
 3. Place the disc in the tray with the label facing up.
 4. Press the PLAY/PAUSE key.
- After the final selection has been played, the player will go into the stop mode.

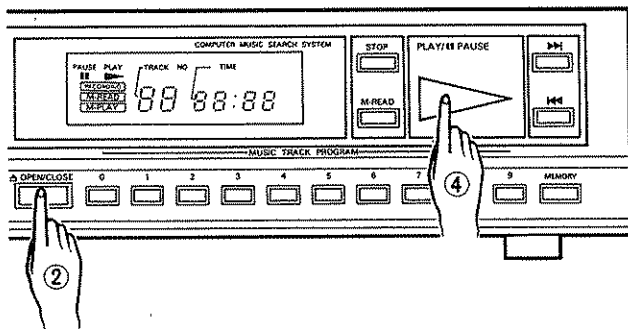

To use the pause mode

Press the PLAY/PAUSE key.

- The PAUSE indicator will light up and the pickup will stop at that point.
- Press the PLAY/PAUSE key again to restart playing from the point.

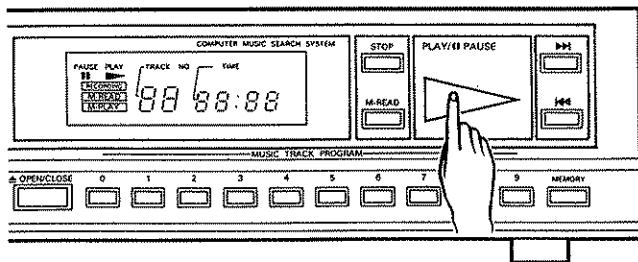

To stop disc play

Press the STOP key.

Play will stop, the pickup will return to the beginning of the first selection.

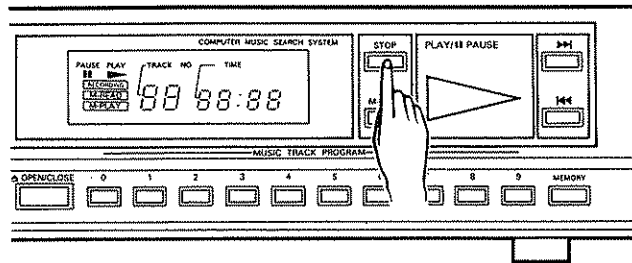

To play a particular track

1. Select the desired Track No. using the MUSIC TRACK PROGRAM keys or >>> or <<< keys.
 2. Press the PLAY/PAUSE key within about 3 seconds after selection.
- The Track No. and the PLAY indicator will light up. After the pickup has moved to the beginning of the tune, the player will begin play.
 - After the final selection has been played, the pickup will automatically return to the beginning of the first selection.

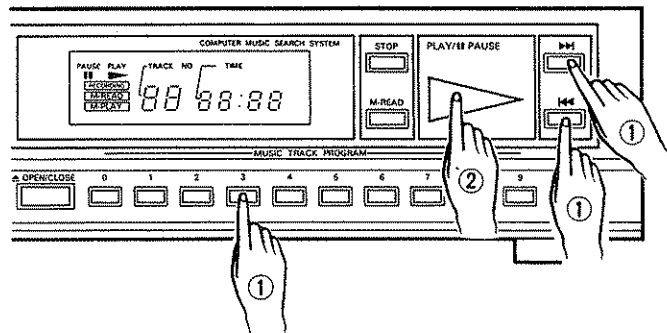

To select another selection during play

1. Press the >>> key. The pickup will search the beginning of the next selection.
- When it is done during play of the final selection, the pickup will return to the beginning of the first selection.
2. A press of the <<< key will move the pickup to the beginning of the selection being played.
3. When the MUSIC TRACK PROGRAM key is pressed, the player will stop playing and move the pickup to the beginning of the selected track. (When pressing two MUSIC TRACK PROGRAM keys, press within 4 seconds.) (The player will start play in about 4 seconds after keying in the Track No. with these keys.)
- When the MUSIC TRACK PROGRAM key is pressed during pause, the pickup will come to the beginning of the selected track while remaining in the pause mode.
- Even with the disc tray open, a press of a MUSIC TRACK PROGRAM key or the >>> or <<< key, will display the selected track. A subsequent press of the PLAY/PAUSE key will automatically close the tray and start play from the selection. If the PLAY/PAUSE key is pressed again so

that the PAUSE indicator, the pickup will go into the pause mode at the beginning of the selection.

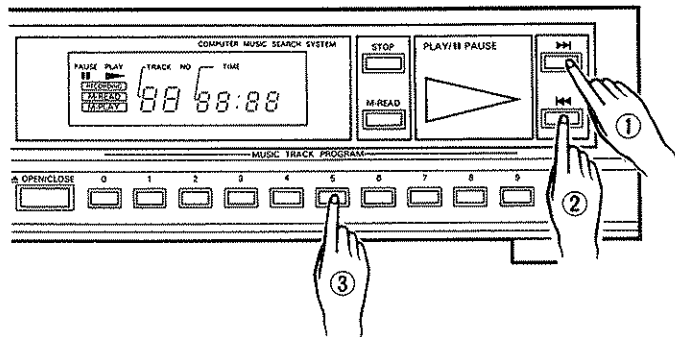

Memory play

The memory play allows the desired tunes to be played in the desired order. The maximum of 16 selections can be put into memory.

■ To program the selection

1. Press the STOP key.
2. Select the desired Track No. using the MUSIC TRACK PROGRAM keys or ►► or ◀◀ keys.
3. Press the MEMORY key.
 - The Track No. will be back lit, and the selected track will be memorized in Channel 1.
 - Unless the MEMORY key is pressed within 3 seconds after selecting the Track No., the programming will be aborted.
4. To continue to program further selections, repeat the procedures in 2. and 3. The maximum number of selections for memory is 16. More than 16 selections cannot be memorized. Any attempt to program tunes exceeding the number will be cancelled.
 - To program quickly without waiting 2 or 3 seconds, select the next Track No. When the next Track No. is selected, the current memory operation is completed.

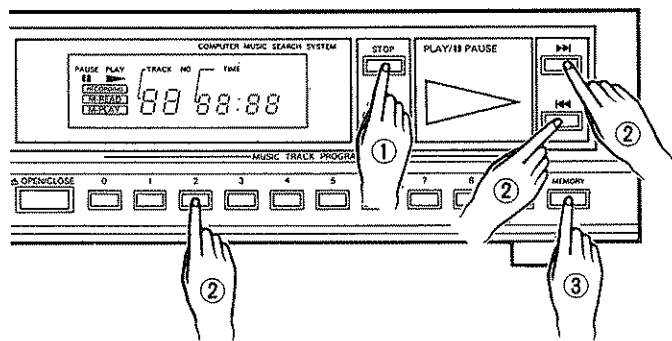

■ To confirm a memorized selection

Press the M-READ key.

- The Track No. and Channel No. of the memorized selections can be confirmed beginning at the Channel 1. Each channel contents will be displayed for about 3 seconds. Memory indications will not appear when the selections are not in memory.

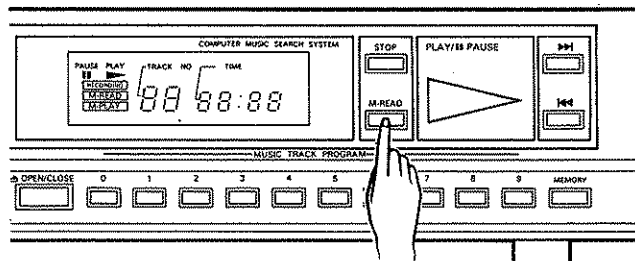

■ To erase the memory

Press the STOP key.

- The memory of all channels will be erased.
- The memory will also be erased when the disc tray is opened with the OPEN/CLOSE switch or the power is turned off.

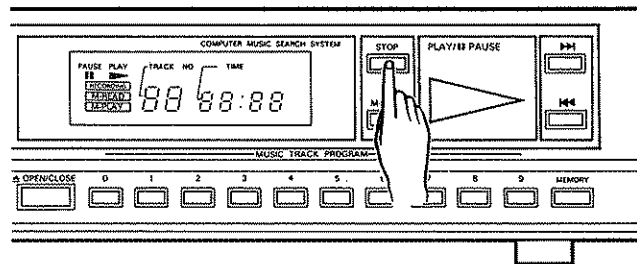

■ To play the memorized selections

1. Program the desired selections in accordance with the procedures in "To program the selection" on page 7.
2. Press the PLAY/PAUSE key.
 - The M-PLAY indicator will light to show that the player is in the memory play mode.
 - The player will play only memorized channels. After the final channel has been played, the player will go into the stop mode erasing all the memory contents.
 - In the memory play mode, a blank of more than 4 seconds will automatically be placed between selections.

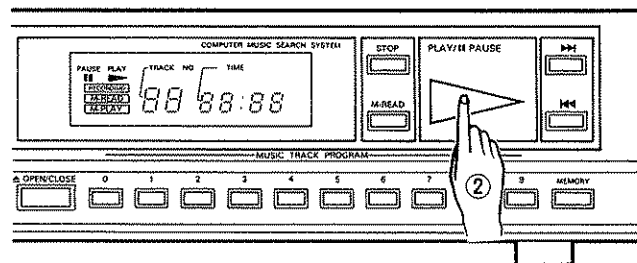

■ To use the pause mode

Press the PLAY/PAUSE key once.

- The PAUSE indicator will light to stop play at the point where the PLAY/PAUSE key was pressed.
- To resume play, press the PLAY/PAUSE key again.

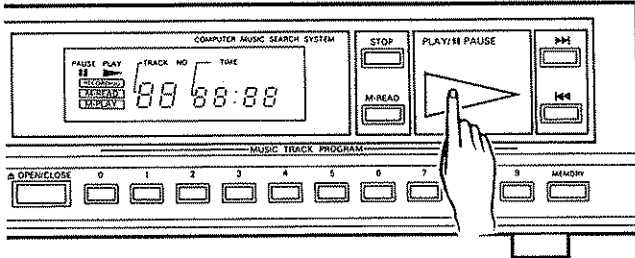

■ To stop memory play

Press the STOP key.

- Play is discontinued, the pickup returns to the beginning of the first selection of the disc, and the disc will stop.
- All the memorized contents will be erased.

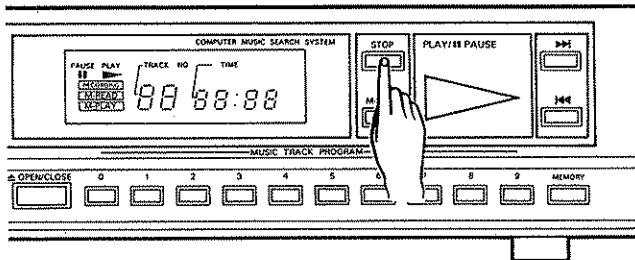

■ To play from a specific selection

1. Press the >>> or <<<< key to call on the desired channel.
2. Press the PLAY/PAUSE key.

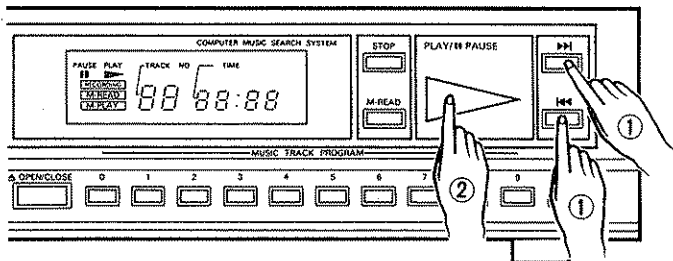

■ To select another selection during play

Press the >>> key. Play will then be discontinued and the pickup will advance to the next selection on the disc.

1. When the key is pressed during play of the final selection, the pickup will return to the first channel of the memory.
 2. If the <<<< key is pressed, play will also be discontinued, and the pickup will return to the beginning of the selection under play.
- A continuous press of the key will reverse the pickup to the beginning of the previous selection.
 - When the player is in the pause mode, the pickup will move to the beginning of the selected track.

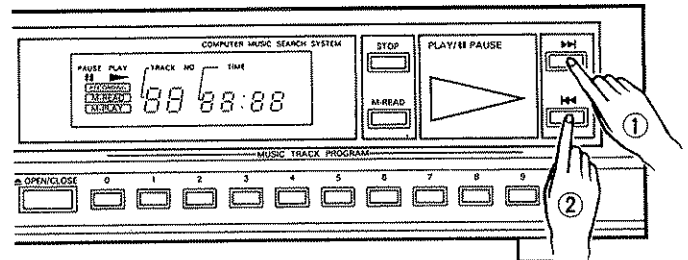

Synchro Operation

The combination of this player and the MIDI M-7 or M-5 via a synchro cord will provide easy play and recording of a Compact Disc. For details, refer to Instruction Manual for MIDI M-7 or M-5.

■ Synchro play

1. The disc will be played in accordance with the procedures in "To Play a Disc" on page 6. Press the PLAY/PAUSE key, and the input mode indicator of the amplifier will automatically switch to CD and start play.
2. Adjust sound volume and quality of the amplifier.
3. After the final selection has been played, the pickup will stop at the beginning of the first selection. Press the STOP key to stop synchro play.

■ Synchro recording

<To record a manual play>

1. Place a cassette tape in the deck.
2. Set the cassette deck in REC PAUSE mode.
3. Set a disc in accordance with 1. to 3. of "To Play a Disc" on page 6.
4. Press the PLAY/PAUSE key.
The RECORDING indicator will light and recording will start.

<To play the memory play>

1. Place a cassette tape in the deck.
2. Key-in the desired memory in accordance with the "To Program the Selection" on page 7.
3. Press the PLAY/PAUSE key of this unit.
The RECORDING indicator will light and recording will start.
After the final selection of the disc or the final memorized selection has been recorded, the disc will stop at the beginning of the disc, and the deck will stop after making a blank of 4 seconds after the tune.
To stop recording, press the STOP key of this unit. Then the disc will stop at the beginning of the first selection, and the deck will stop after making a blank of 4 seconds after the recording.

Notes:

1. When either A or B of the double cassette deck is in the play mode, synchro recording is not possible.
2. When either A or B of the double cassette deck is in the record mode, the rec pause mode is not activated. Set the input mode switch of the amplifier to CD, and press the REC key.

- Synchro recording is possible by combining this unit with the MIDI M-3 via synchro cord. Refer to the Instruction Manual of the MIDI M-3.

Note:

When recording, be sure to start recording from the stop mode. If started from the pause mode, the selection will not be recorded from the beginning.

Notes on handling compact discs

Handling

Compact discs are made of plastic (polycarbonate). When the recorded side of the compact disc is dirty or scratched, playback may be noisy or sound may be missed. Even when the label side is scratched, the recording may be damaged. Handle compact discs carefully. Do not stick tape, etc. to compact discs.

Cleaning

When a compact disc is contaminated with fingerprints, etc., wipe with a dry cloth in a radial direction. Never use chemical solvents, such as thinner, benzene, etc. and conventional record cleaners or aerosols.

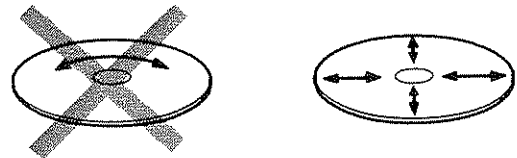

Storage

Always replace the compact disc in its case and store it. Compact discs are adversely affected by heat and moisture. Do not store compact discs in a place exposed to direct sunlight or where humidity is high.

Additional precautions

When performing connections, always disconnect the power cord from the AC outlet. When setting the power switch (POWER) to OFF, always turn the volume control of the amplifier to minimum.

In case of difficulty

If your unit should not perform as expected, consult the table below to see if the problem can be corrected before seeking help from your dealer or service representative.

Symptom	Possible cause	Remedy
Even when the POWER switch is turned ON, the power is not supplied.	The power plug is not properly fitted.	Reconnect the power plug properly into the AC outlet.
When a disc is loaded, it does not start play.	<ol style="list-style-type: none"> 1. Disc is loaded upside down. 2. Disc is dirty. 3. Optical system collects dew. 4. The player is in the roulette play mode. 	<ol style="list-style-type: none"> 1. Reverse the disc. 2. Clean. 3. Keep the unit warm for an hour. 4. The amplifier should be switched out of the roulette play mode.
No sound.	Loose connection	Connect the connection cord tightly.
Sound skipped	<ol style="list-style-type: none"> 1. Disc is very dirty. 2. Disc is greatly damaged. 3. Vibration is transmitted to the unit. 	<ol style="list-style-type: none"> 1. Clean. 2. Replace the disc with the new one. 3. Move the unit to a place where no vibration is transmitted to the set.
Selection searching time is extremely long.	Disc is dirty or damaged.	Clean the disc or replace it with the new one.
Tray does not open even after the OPEN/CLOSE switch is pressed.	<ol style="list-style-type: none"> 1. Improper insertion of a power plug. 2. Transportation screw is not removed. 	<ol style="list-style-type: none"> 1. Insert the power plug tightly into the AC outlet. 2. Remove the transportation screw.

In compliance with Federal Regulations, following are reproductions of labels on, or inside the product relating to laser product safety.

TRIO KENWOOD CORPORATION
 SHIONOGI SHIBUYA BUILDING
 17-5, 2-CHOME, SHIBUYA,
 SHIBUYA-KU, TOKYO, JAPAN

TRIO-KENWOOD CORP. CERTIFIES THIS EQUIPMENT
 CONFORMS TO DHHS REGULATIONS NO. 21 CFR,
 CHAPTER I, SUBCHAPTER J.

DANGER LASER RADIATION
 WHEN OPEN AND INTERLOCK FAILED
 OR DEFEATED. AVOID DIRECT
 EXPOSURE TO BEAM.

Specifications

Number of channels	2 channels
Frequency response	4 Hz — 20 kHz, ± 0.5 dB
Dynamic range	93 dB
Total harmonic distortion	0.002% at 1 kHz
Channel separation	90 dB at 1 kHz
Line output level	2.0 V
Headphones output level/impedance ..	5 mW/32 ohms
Quantization	16 bits linear 2 channels
Sampling Frequency	44.1 kHz
Pick up type	Optical pick up
Laser type	Semiconductor laser
Power requirements	120 V/220 — 240 V, 50/60 Hz (Switchable)
Power consumptions	15 W
Dimentions	W 340 mm (13-13/32") H 74 mm (2-15/16") D 351 mm (13-13/16")
Weight	4.9 kg (10.8 lb)
Supplied accessories	Connection cables (RCA 2 PIN cord, RCA 1 PIN cord, Synchro cord with mini plug)

Note:

We follow a policy of advancements in development. For this reason specifications may be changed without notice.

TRIO