

Electrolux

Refrigeration SMART 2 Split Door Refrigerator (50 FT³)

ITEM # _____
 MODEL # _____
 PROJECT NAME # _____
 SIS # _____
 AIA # _____



Refrigeration SMART 2 Split Door Refrigerator (50 FT³)

726679 (RH14RE4HU) 50 ft³ Full Size Refrigerator
 2 split door 115 V/1p/60Hz
 727022 (RH14RE4HRU) 50 ft³ Full Size Refrigerator
 2 split door 115 V/1p/60Hz
 remote version

Short Form Specification

Item No. _____

The Electrolux range of refrigerated cabinets are built with external and internal AISI 304 stainless steel. High-density expanded polyurethane insulating foam, 3" (75 mm) in thickness. Full door with lock and microswitch to switch off the fan when the door is opened. Built-in refrigeration unit; ventilated operating mode; SMART Electronic Control equipped with: history (HACCP) for critical high temperature, alarm service, full diagnostic, remote control via modem; electronic defrost only when required; defrost outlet pipe; external digital temperature display. Humidity level adjustment. Internal lighting. Cavity drain. For ambient temperatures up to 110 °F (43 °C). CFC and HCFC free. R134a gas in refrigeration circuit. Gas in foam: cyclopentane. EnergyStar certification for energy savings. Supplied with n. 4 x 2/1GN Rilsan coated grids and n. 4 sets of 2 stainless steel grid runners.

Covered by Electrolux Platinum Star® Service Program two-year parts and one-year labor warranty, installation start-up and performance check-up after one year from installation.



Approval: _____

Main features

EASY TO INSTALL

- Mounted on adjustable stainless steel feet, with castors as an option.
- Choice of doors to suit varying kitchen requirements.
- Refrigerator models have operating temperatures that can be adjusted from 28 °F to 50 °F (-2.22 to 10 °C) to suit both meat and dairy storage requirements.
- Performance guaranteed at ambient temperatures of 110 °F (43 °C).

EASY TO CLEAN

- Forced air circulation for rapid cool down and even temperature uniformity.
- Constructed from the highest quality AISI 304 stainless steel.
- Interior base with corners, pressed from a single sheet.
- Sides and back of the 1-door models are formed from a single sheet of stainless steel to avoid dirt traps.
- Evaporator unit is placed outside the cell to provide the maximum storage capacity.
- Refrigerators are fitted with outlet pipe.

EASY TO USE

- Accommodates GN 2/1 containers or shelves on anti-tilt runners.
- External digital temperature display.
- Interior light and lockable door.
- SMART electronic control gives the following benefits:
- HACCP: when temperature exceeds critical limits, an acoustic and visual alarm are activated. All events are recorded displaying date and time of all events.
- SMART defrost: the defrost cycle is activated only when necessary thanks to the four-probe control and a patented algorithm for ice detection.
- Intelligence when failure: when a probe breaks it remembers its performance of last 24 hours and continue to work. In this way food is safe and service can be called.
- Diagnostic: four probes constantly control working condition of the appliances.
- Food categories: depending by food stored it can be selected appropriate temperature and humidity just pushing a button.

EASY TO MAINTAIN

- Heavy-duty construction that avoids use of any plastic parts.
- The cooling unit (compressor, condenser and evaporator) can be removed with a single operation from either the top or back.
- Evaporator cover is easily removable for service.
- Fault indication from the smart control.

EASY ON THE ENVIRONMENT

- SMART electronics defrost only when required to save energy.
- Cabinet fitted with up to 3" (75 mm) thickness of cyclopentane insulation for best insulating performance. CFC and HCFC-free insulation.
- Refrigerant type: R134a or R404a.

Accessories

- Pair of stainless steel runners for 23 and 50 ft³ SMART refrigerators 8
- Rilsan® coated full-size sheet grid 8

Optional Accessories

- Basic HACCP Printer (PNC 880048)
- 4 wheels (2 with brake) (PNC 880121)
- Pair of stainless steel runners for 23 and 50 ft³ SMART refrigerators (PNC 880175)
- Rilsan® coated full-size sheet grid (PNC 880176)
- Pedal opening for 50 ft³ SMART refrigerators (PNC 881459)



Electrolux

SMART 2 Split Door Refrigerator (50 FT³) Refrigeration

Electrolux Professional, Inc.

www.electroluxusa.com/professional

3225 SW 42nd Street, Fort Lauderdale, Florida, 33312 • Telephone Number: 866-449-4200 • Fax Number: 954-327-6789

Front View

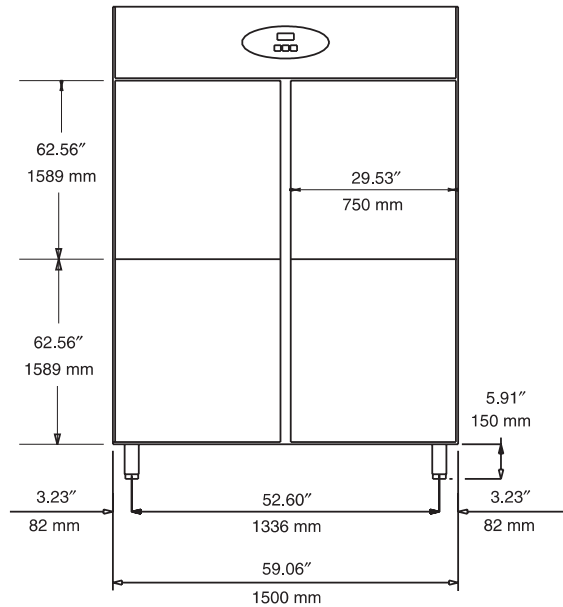

Top View

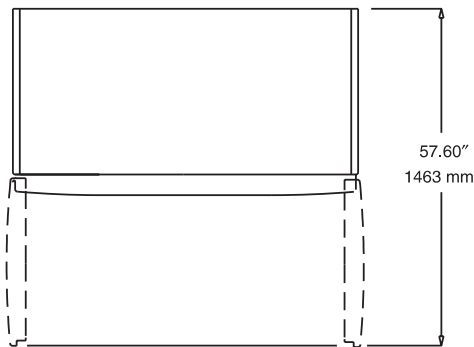

EC = Electrical connection
D = Water drain

Side View

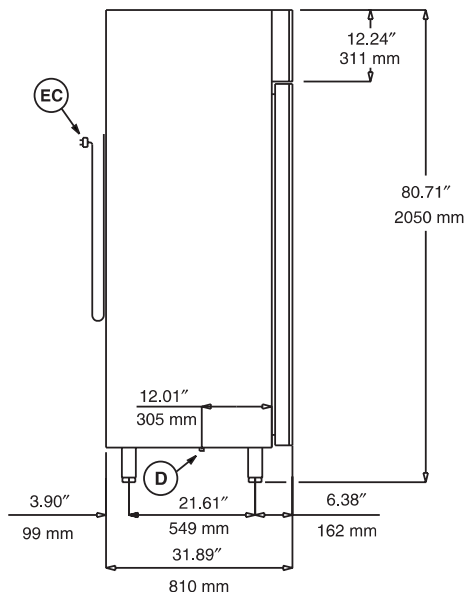

Electric

Supply voltage:

726679 (RH14RE4HU)	115 V/1p/60Hz - 10A
727022 (RH14RE4HRU)	115 V/1p/60Hz - 10A

Key Information

LEGEND

C - Water Drain	1/2" (12.7 mm)
I - Electrical Connection	115 V/1p/60Hz

TECHNICAL DATA

Operating temperature min.: 28 °F (-2.22 °C)

Operating temperature max.: 50 °F (10 °C)

Built-in Compressor and Refrigeration Unit

External Dimensions:

Width:	59" (1500 mm)
Depth:	31-7/8" (810 mm)
Depth (with doors open)	57-1/2" (1463 mm)
Height:	80-11/16" (2050 mm)

Min/Max internal humidity % : 50/ 80

Number and type of doors: 4 Half

Door hinges: 1 Left, 1 Right

Number and type of grids (included): 8, GN 2/1

Compressor power: 3/8 HP

Refrigerant type: R134a

Refrigerant quantity: 410g

Refrigerant Power: 450W

Power: 515 watts

Net weight: 547 lbs (248 kg)