

# Electrolux

## Refrigeration

### SMART 1 Door Dual Temp Refrigerator/Freezer (23 FT<sup>3</sup>)

ITEM # \_\_\_\_\_

MODEL # \_\_\_\_\_

PROJECT NAME # \_\_\_\_\_

SIS # \_\_\_\_\_

AIA # \_\_\_\_\_



#### Refrigeration SMART 1 Door Dual Temp Refrigerator/Freezer (23 FT<sup>3</sup>)

726483 (RH06DFD2U) 23 ft<sup>3</sup> Full Size Dual Temp Refrigerator  
1 door 115 V/1p/60Hz

#### Short Form Specification

Item No. \_\_\_\_\_

The Electrolux HD-Line offers one of the most comprehensive choices of refrigerated storage cabinets available. Manufactured internally and externally in 304 AISI stainless steel, operating over refrigeration or freezer temperature ranges, with solid doors, and in a choice of either 23 ft<sup>3</sup> or 50 ft<sup>3</sup> capacity.

Covered by Electrolux Platinum Star<sup>®</sup> Service Program two-year parts and one-year labor warranty, installation start-up and performance check-up after one year from installation.



5-15P

Approval: \_\_\_\_\_

#### Main features

##### EASY TO INSTALL

- Mounted on adjustable stainless steel feet, with castors available as an option.
- Choice of doors to suit varying kitchen requirements.
- Refrigeration operating temperatures that can be adjusted from 28 °F to 50 °F (-2.22 to 10 °C) to suit both meat and dairy storage requirements. Freezer temperature can be adjusted from 5 °F to -11 °F (-15 to -24 °C).
- Suitable for ambient temperatures up to 110 °F (43 °C).

##### EASY TO CLEAN

- Constructed from the highest quality AISI 304 stainless steel with radiused corners to the interior base, which is pressed from a single sheet.
- Sides and back are formed from a single sheet of stainless steel to avoid dirt traps.
- Evaporator unit is inset into the top of the refrigerated chamber to provide an obstruction free interior.

##### EASY TO USE

- Forced air circulation for rapid cool down and even temperature uniformity.
- Accommodates GN 2/1 containers or shelves on anti-tilt runners.
- External digital temperature display.
- Interior light
- Lockable door.
- Refrigerators feature automatic defrost and are fitted with a defrost outlet pipe.

##### EASY TO MAINTAIN

- Heavy-duty construction that avoids use of any plastic parts.
- Single refrigeration unit (compressor, condenser and evaporator) that can be removed in a single piece from either the top or back.
- Evaporator cover is easily removable for maintenance.

##### EASY ON THE ENVIRONMENT

- 20% reduction in energy consumption compared to previous models.
- Cabinet fitted with up to 3" (76 mm) thickness of cyclopentane insulation for best insulating performance with 100% environmental protection.
- Refrigerants type: R134a and R404a.

#### Accessories

- Pair of stainless steel runners for 23 and 50 ft<sup>3</sup> SMART refrigerators 4
- Rilsan<sup>®</sup> coated full-size sheet grid 4

#### Optional Accessories

- Basic HACCP Printer (PNC 880048)
- 4 wheels (2 with brake) (PNC 880121)
- Pair of stainless steel runners for 23 and 50 ft<sup>3</sup> SMART refrigerators (PNC 880175)
- Rilsan<sup>®</sup> coated full-size sheet grid (PNC 880176)
- Pedal opening for 23 ft<sup>3</sup> SMART refrigerators (PNC 881458)



# Electrolux

SMART 1 Door Dual Temp Refrigerator/Freezer (23 FT<sup>3</sup>)  
Refrigeration

Electrolux Professional, Inc.

www.electroluxusa.com/professional

3225 SW 42nd Street, Fort Lauderdale, Florida, 33312 • Telephone Number: 866-449-4200 • Fax Number: 954-327-6789

**Front View**

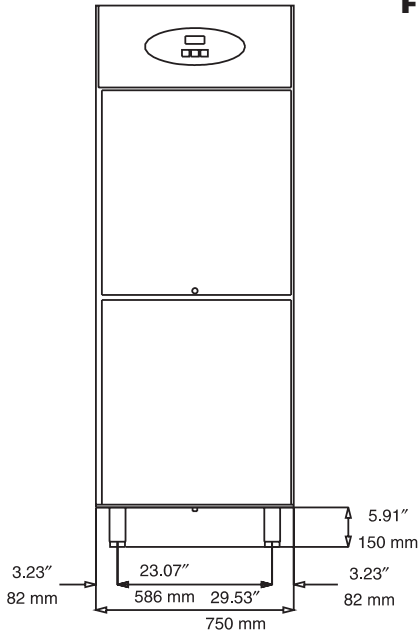

**Top View**

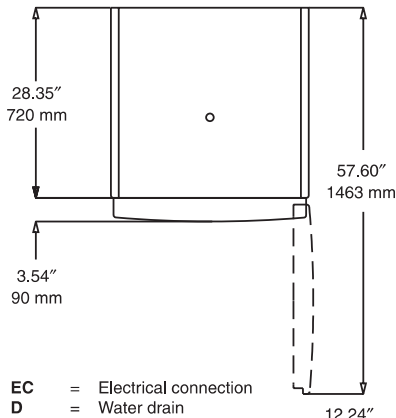

**Side View**

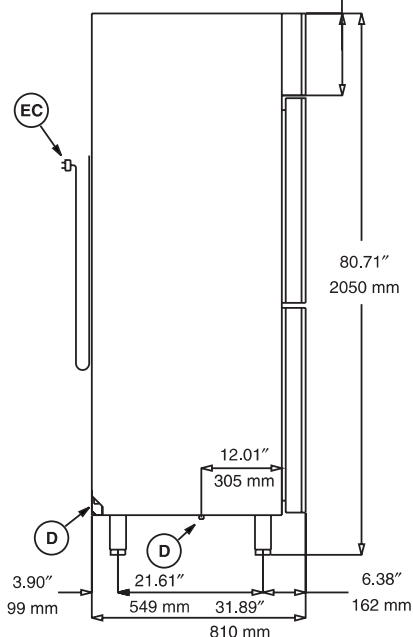

### Electric

**Supply voltage:**

726483 (RH06DFD2U)

115 V/1p/60Hz - 12A

### Key Information

**LEGEND**

C - Water Drain 1/2" (12.7 mm)

I - Electrical Connection 115 V/1p/60Hz

**TECHNICAL DATA**

Operating temperature min.: 28 °F (-2.22 °C)

Operating temperature max.: 50 °F (10 °C)

**Built-in Compressor and Refrigeration Unit**

**External Dimensions:**

Width: 29-1/2" (749. mm)

Depth: 31-7/8" (810 mm)

Height: 80-11/16" (2049 mm)

Min/Max internal humidity %: 75/ 90

Number and type of doors: 2 Half

Door hinges: Right

Number and type of grids (included): 4, GN 2/1

Compressor power: 1/5 HP

Refrigerant type: R134a

Refrigerant quantity: 200g

Refrigerant Power: 250W

Power: 640 watts

Net weight: 370 lbs (168 kg)

**Configuration:**

Top: Refrigerator

Bottom: Freezer