

*fridge*

# USER MANUAL

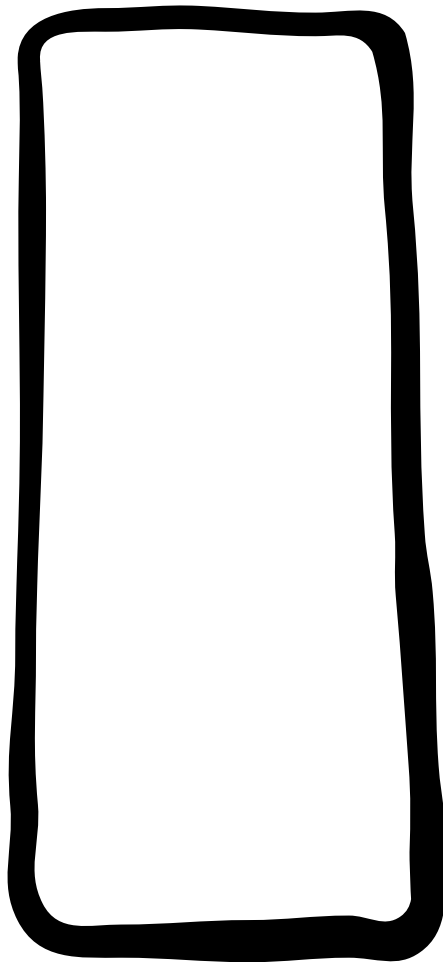

**ERN 34800**

*Thinking of you*

 **Electrolux**

# IMPORTANT SAFETY INFORMATION

It is most important that this instruction book should be retained with the appliance for future reference. Should the appliance be sold or transferred to another owner, or should you move house and leave the appliance, always ensure that the book is left with the appliance in order that the new owner can get to know the functioning of the appliance and the relevant safety information.

This information has been provided in the interest of safety. You **MUST** read it carefully before installing or using the appliance.

## Installation

- This appliance is heavy. Care should be taken when moving it.
- It is dangerous to alter the specifications or attempt to modify this product in any way.
- Care must be taken to ensure that the appliance does not stand on the electrical supply cable.  
**Important:** if the supply cable is damaged, it must be replaced by a special cable available from your local Service Force Centre.
- Any electrical work required to install this appliance should be carried out by a qualified electrician or competent person.
- Parts which heat up should not be exposed. Whenever possible, the back of the appliance should be close to a wall but leaving the required distance for ventilation as stated in the installation instructions.
- The appliance should be left for 2 hours after installation before it is turned on, in order to allow the refrigerant to settle.

## Child Safety

- Do not allow children to tamper with the controls or play with the product.
- Keep all packaging well away from children.

## General Safety

- **This appliance contains hydrocarbons in its cooling unit; maintenance and recharging must therefore only be carried out by authorized technicians.**
- **Take utmost care when handling your appliance so as not to cause any damages to the cooling unit with consequent possible fluid leakages.**
- **The appliance must not be located close to cookers, radiators or boilers.**
- **Avoid prolonged exposure of the appliance to direct sunlight.**
- **Do not use other electrical appliances (such as ice cream makers) inside of refrigerating appliances.**

## During Use

- This appliance is designed for domestic use only, specifically for the storage of edible foodstuffs.

- Frozen food must NOT be re-frozen once it has thawed out.
- Do not place carbonated or fizzy drinks in the freezer.
- Do not remove items from the freezer if your hands are damp/wet, as this could cause skin abrasions or frost/freezer burns.
- Ice lollies can cause 'frost/freezer burns' if consumed straight from the freezer.
- Manufacturers' storage recommendations should be strictly adhered to. Refer to relevant instructions.
- The cooling plate or refrigerated freezer shelves in this appliance contain channels through which the refrigerant passes. If these are punctured this will cause substantial damage to the appliance and result in food loss. **DO NOT USE SHARP INSTRUMENTS** to scrape off frost or ice. Under **NO** circumstances should solid ice be forced off the lining or shelves. Solid ice should be allowed to thaw, when defrosting the appliance. See Defrost Instructions.

## Maintenance and Cleaning

- Switch off and unplug the appliance before carrying out any cleaning or maintenance work.

## Servicing

- This product should be serviced by an authorised engineer and only genuine spare parts should be used.
- Under no circumstances should you attempt to repair the machine yourself. Repairs carried out by inexperienced persons may cause injury or serious malfunctioning. Refer to your local Service Force Centre and always insist on genuine spare parts.

## At the end of the Appliance Life

- When disposing of your appliance, use an authorised disposal site.
- Remove the plug and ensure that any locks or catches are removed, to prevent young children being trapped inside.

# Disposal of old Appliances



The symbol  on the product or on its packaging indicates that this product may not be treated as household waste. Instead it should be taken to the appropriate collection point for the recycling of electrical and electronic equipment. By ensuring this product is disposed of correctly, you will help prevent potential negative consequences for the environment and human health, which could otherwise be caused by inappropriate waste handling of this product. For more detailed information about recycling of this product, please contact your local council, your household waste disposal service or the shop where you purchased the product.

## CONTENTS

### Instructions for the User

<b>Important Safety Information</b>	2
<b>Operation</b>	4
Before use	4
Control panel	4
Display	4
Operation	4
Activation of functions	4
Switching off	4
Use of the fridge compartment	5
Setting the temperature	5
Fresh food refrigeration	5
Shopping Function	5
Door open acoustic alarm	5
Normal operating sounds	5
Movable shelves	6
Positioning the door shelves	6
Bottle holder	6
Air recycling	6
<b>Hints and Tips</b>	<b>7</b>
<b>Maintenance and Cleaning</b>	<b>8</b>
Internal cleaning	8
External cleaning	8
When the appliance is not in use	8
Changing the light bulb	8
Defrosting	8
<b>Something Not Working</b>	<b>9</b>
<b>Service and Spare Parts</b>	<b>10</b>
<b>Customer Care</b>	<b>10</b>
<b>Guarantee Conditions</b>	11

### Instructions for the Installer

<b>Technical Specification</b>	12
<b>Installation</b>	13
Positioning	13
Shelf holders	13
<b>Electrical Connection</b>	14
<b>Instruction for totally built-in appliances</b>	15

# OPERATION

## Before using

Remove all securing tapes. Wash inside the appliance with lukewarm water and bicarbonate of soda (5 ml to 0.5 litre of water).

**Do not use soap or detergent as the smell may linger. Dry thoroughly.**

## Control panel

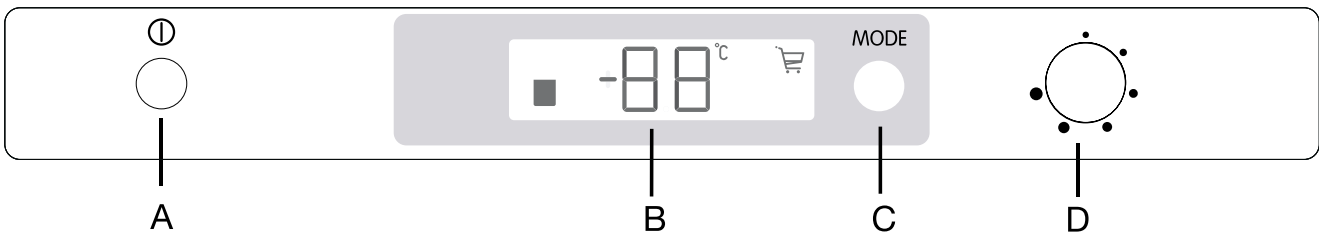

A - Appliance button ON/OFF  
B - Temperature and function indicator

C - Function button  
D - Fridge Thermostat knob

## DISPLAY

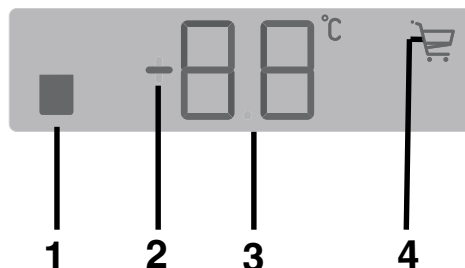

1. Door open alarm indicator
2. Positive or negative Temperature indicator
3. Temperature indicator
4. If on the shopping function is on

## Operation

After plugging the plug into the power outlet, if the display is not illuminated, press key (A), appliance on.

As soon as the appliance is turned on, the following signals will appear on the control panel:

- symbol (2) will be positive, indicating that the temperature is positive.

Turn the refrigerator thermostat knob (D) to the middle position, this will adjust the temperature to approx. +5°C, which is considered sufficiently cold for the safe storage of food.

## Activation of functions

Each time key C is pressed, the following functions are activated in a clockwise direction:

Symbol 4 : shopping function

No Symbol: Normal operation

## Switching off

The appliance is shut off by holding down key (A) for more than 1 second. After this, a countdown of the temperature from -3 -2 -1 will be shown.

When the appliance is shut off, display (B) also goes off.

# Use of the fridge compartment

## Setting the temperature

The temperature within the appliance is controlled by the thermostat control knob situated at the top of the appliance.

To operate the appliance proceed as follows:

Turn the thermostat control beyond the «O» position.

Position ● = minimum coldness

Position ● = maximum coldness

Turn the thermostat dial to the required position.

**The intermediate position is usually the most suitable.**

The thermostat setting can vary as the temperature inside the appliance depends on the following factors:

- room temperature
- how often the door is opened
- how much food is stored
- position of the appliance

## Shopping Function

If you need to insert a large amount of warm food, for example after doing the grocery shopping, we suggest activating the Shopping function to chill the products more rapidly and to avoid warming the other food which is already in the refrigerator and/or freezer.

The shopping function is activated by pressing key C (several times if necessary) until the corresponding

icon appears 

The shopping function shuts off automatically after approximately 6 hours.

It is possible to de-activate the function at any time by pressing key C (see paragraph "Function Activation").

## Fresh food refrigeration

To obtain the best performance, do not store warm food or evaporating liquids in the refrigerator; cover or wrap the food, particularly if it has a strong flavour.

Do not cover the shelves with any protective material, such as paper, cardboard or plastic, which may obstruct the air circulation.

To help you use your refrigerator correctly, here are some more useful hints:

Raw meat (beef, pork, lamb & chicken or poultry): wrap in polythene bags and place on the glass shelf above the salad drawers.

**Meat can only be stored safely in this way for one or two days at the most.**

Fruit & vegetables: these should be thoroughly cleaned and placed in the salad drawers.

Butter & cheese: these should be placed in special airtight containers or wrapped in aluminium foil or polythene bags to exclude as much air as possible.

Milk bottles: these should have a cap and should be stored in the bottle rack on the door.

## Door open acoustic alarm

An acoustic alarm will sound when the door is left open for around 5 minutes.

The door open alarm conditions are indicated by:

- flashing symbol (1);
- red display illumination;
- beeping sound.

Press the button (C) to stop the acoustic alarm.

When normal conditions are restored (door closed):

- the acoustic alarm will stop.

## Normal Operating Sounds

- You may hear faint gurgling or bubbling sounds when the refrigerant is pumped through the coils or tubing at the rear, to the cooling plate/evaporator.
- When the compressor is on, the refrigerant is being pumped round, and you will hear a whirring sound or pulsating noise from the compressor.
- A thermostat controls the compressor, and you will hear a faint 'click' when the thermostat cuts in and out.

## Movable shelves

The walls of the refrigerator have runners so that the shelves can be positioned as desired .

For better use of space, the front half-shelves can lie over the rear ones.

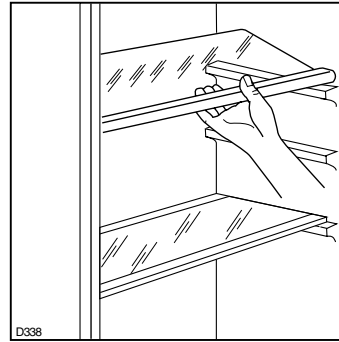

## Positioning the door shelves

To permit storage of food packages of various sizes, the door shelves can be adjusted in height. To make these adjustments proceed as follows:

Gradually pull the shelf in the direction of the arrows until it comes off, then reposition as required.

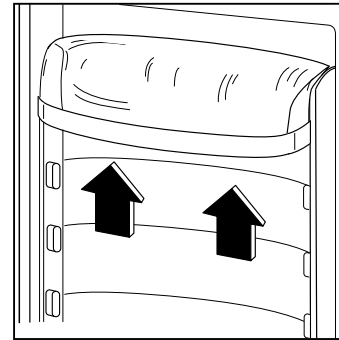

## Bottle holder

Place the bottles (with the opening facing front) in the pre-positioned shelf.

If the shelf is positioned horizontally, place only closed bottles.

This bottle holder shelf can be tilted in order to store previously opened bottles.

To obtain this result, pull the shelf up so it can rotate upwards and be placed on the next higher level.

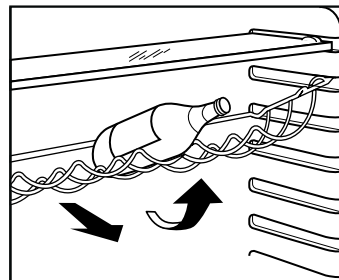
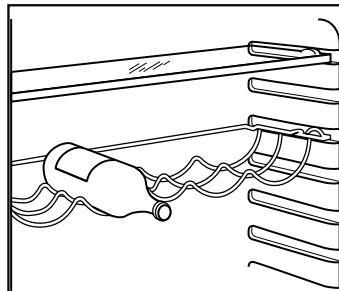

## Air recycling

The refrigerator compartment is equipped with a special D.A.C.(Dynamic Air Cooling) fan which can be turned on with the switch A ( see fig. 1). The green light, when on, means that the fan is working.

It is suggested that the fan (D.A.C.) be used when the ambient temperature exceeds 25°C.

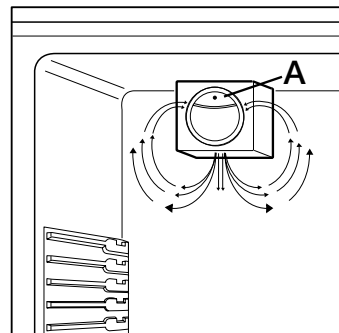

Fig.1

# HINTS AND TIPS

## Food Storage

- To obtain the best results from the appliance neither hot foods nor liquids which may evaporate, should be placed in the larder compartment.
- Keep the time between buying chilled food and placing it in your refrigerator as short as possible.
- Do not push food together too much, try to allow air to circulate around each item.
- Do not store food uncovered.
- Remove suspect food from your refrigerator and clean, refer to Maintenance and Cleaning.



## Energy Saving Advice

- Do not install the appliance close to sources of heat, such as a boiler or radiator.
- Locate the appliance in a cool well ventilated room and make sure that the air openings of the appliance are not obstructed.
- Always leave warm food to cool down to room temperature before placing in the fridge.
- Try to avoid keeping the door open for long periods or opening the door too frequently as warm air will enter the cabinet and cause the compressor to switch on unnecessarily often.
- Ensure there are no obstructions preventing the door from closing properly.
- It is advisable to periodically clean the refrigeration system at the back of the appliance with a duster or vacuum cleaner.

# MAINTENANCE AND CLEANING

Before any maintenance or cleaning work is carried out, DISCONNECT the appliance from the ELECTRICITY supply.

## Internal cleaning

Clean the inside and accessories with warm water and bicarbonate of soda (5ml to 0.5 litre of water). Rinse and dry thoroughly.

 **NEVER USE DETERGENTS, ABRASIVE POWDERS, HIGHLY PERFUMED CLEANING PRODUCTS OR WAX POLISHES, TO CLEAN THE INTERIOR AS THESE WILL DAMAGE THE SURFACE AND LEAVE A STRONG ODOUR.**

## External cleaning

An accumulation of dust will affect the performance of the appliance and cause excessive electricity consumption.

Once or twice a year dust the condenser (black grill) and the compressor at the back of the appliance, with a brush or vacuum cleaner, see figure.

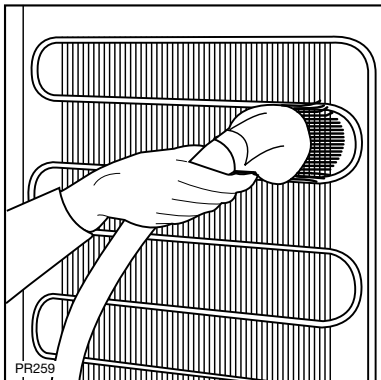

## Defrosting

The refrigerator automatically defrosts every time the compressor stops. The water is discharged, via the pipe, into a tray located at the back of the appliance above the compressor, where it evaporates.

 **Important**

To avoid defrost water overflowing into the fridge, periodically clean the water discharge hole in the centre of the V shaped drip collector at the back of the refrigerator compartment behind the salad crispers. Use the defrost cleaner provided which you will find already inserted into the discharge hole.

Remember to wash the defrost cleaner in hot soapy water at regular intervals. Dry thoroughly before replacing.

## Changing the light bulb

If it becomes necessary to replace the lamp, press on the rear hook and at the same time slide the cover in the direction indicated by the arrow.

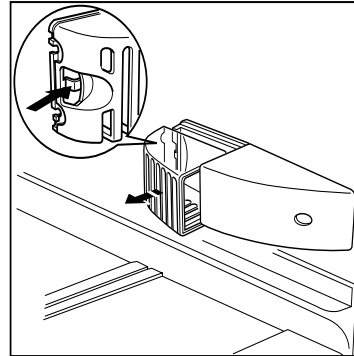

Unscrew the bulb and replace it with one of the same power (the maximum power is shown on the light diffuser) available from your nearest Service Force Centre.

Replace the light cover by sliding it into its original position.

## When the appliance is not in use

When the appliance is not in use for long periods, disconnect from the electricity supply, empty all foods and clean the appliance, leaving the doors ajar to prevent unpleasant smells.

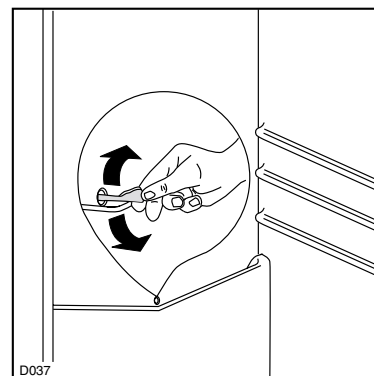



# SOMETHING NOT WORKING

If the appliance is not working correctly, please carry out the following checks before contacting your local Service Force Centre

Symptom	Solution
No power to the appliance	Check there is power at the socket.
	Check there is not a power cut by checking the household lights.
	Check the fuse has not blown.
The light does not come on	Ensure that the bulb is correctly fitted.
	Replace the bulb if it has blown.
The temperature in the fridge	Check the thermostat control knob is turned to the correct setting relative to ambient conditions.
	Check the ambient temperature is within the appliance's operating limits, please refer to the installation section in this instruction book. Relocate the appliance if necessary.
The compressor runs continuously	Adjust the thermostat control knob to give correct temperature control. See "Setting the temperature".
	Check that the door is closed.
	Large quantities of food have recently been placed in the cabinet and/or door is frequently opened.
	Check that air ventilation is not obstructed.
Noise	Refer to normal operating sounds.
Water under the salad crispers	Check the drain hole is not blocked. (see Maintenance and Cleaning).

If after the above checks your appliance still does not operate correctly, contact your local Service Force Centre. Please note that it will be necessary to provide proof of purchase for any in-guarantee service calls.

**In-guarantee customers should ensure that the above checks have been made, as the engineer will make a charge if the fault is not a mechanical or electrical breakdown.**

# SERVICE AND SPARE PARTS

In the event of your appliance requiring service, or if you wish to purchase spare parts, please contact your local Electrolux Service Force Centre by telephoning:-

**0870 5 929929**

Your telephone call will be automatically routed to the Service Force Centre covering your post code area.

For the address of your local Service Force Centre and further information about Service Force, please visit the website at [www.serviceforce.co.uk](http://www.serviceforce.co.uk)

Before calling out an engineer, please ensure you have read the details under the heading 'Something Not Working?'

When you contact the Service Force Centre you will need to give the following details:

1. Your name, address and post code
2. Your telephone number
3. Clear and concise details of the fault
4. The model and serial number of the appliance (found on the rating plate)
5. The purchase date

**Please note that a valid purchase receipt or guarantee documentation is required for in-guarantee service calls.**

## CUSTOMER CARE DEPARTMENT

For general enquiries concerning your Electrolux appliance or for further information on Electrolux products, please contact our Customer Care Department by letter or telephone at the address below or visit our website at [www.electrolux.co.uk](http://www.electrolux.co.uk)

Customer Care Department  
Electrolux Major Appliances  
Addington Way  
Luton  
Bedfordshire  
LU4 9QQ  
08705 950 950 \*

\* calls to this number may be recorded for training purposes.

# GUARANTEE CONDITIONS

## Standard guarantee conditions

We, Electrolux, undertake that if within 12 months of the date of the purchase this Electrolux appliance or any part thereof is proved to be defective by reason only of faulty workmanship or materials, we will, at our option repair or replace the same FREE OF CHARGE for labour, materials or carriage on condition that:

The appliance has been correctly installed and used only on the electricity supply stated on the rating plate.

The appliance has been used for normal domestic purposes only, and in accordance with the manufacturer's instructions.

The appliance has not been serviced, maintained, repaired, taken apart or tampered with by any person not authorised by us.

All service work under this guarantee must be undertaken by an Electrolux Service Force Centre. Any appliance or defective part replaced shall become the Company's property.

This guarantee is in addition to your statutory and other legal rights.

Home visits are made between **8.30am and 5.30pm** Monday to Friday. Visits may be available outside these hours in which case a **premium** will be charged.

## Exclusions

### This guarantee does not cover:

Damage or calls resulting from transportation, improper use or neglect, the replacement of any light bulbs or removable parts of glass or plastic.

Costs incurred for calls to put right an appliance which is improperly installed or calls to appliances outside the European Community (EC) or European Free Trade Area.

Appliances found to be in use within a commercial environment, plus those which are subject to rental agreements.

Products of Electrolux manufacture which are not marketed by Electrolux.

## European Guarantee

If you should move to another country within Europe then your guarantee moves with you to your new home subject to the following qualifications:

The guarantee starts from the date you first purchased your product.

The guarantee is for the same period and to the same extent for labour and parts as exists in the new country of use for this brand or range of products.

This guarantee relates to you and cannot be transferred to another user.

Your new home is within the European Community (EC) or European Free Trade Area.

The product is installed and used in accordance with our instructions and is only used domestically, i.e. a normal household.

The product is installed taking into account regulations in your new country.

Before you move please contact your nearest Customer Care centre, listed below, to give them details of your new home. They will then ensure that the local Service Organisation is aware of your move and able to look after you and your appliances.

France	Senlis	+33 (0)3 44 62 20 13
Germany	Nürnberg	+49 (0)800 234 7378
Italy	Pordenone	+39 (0)800117511
Sweden	Stockholm	+46 (0)20 78 77 50
UK	Luton	+44 (0)8705 950 950

# TECHNICAL SPECIFICATIONS

---

POWER SUPPLY VOLTAGE AND FREQUENCY		220-240 V / 50 Hz
TOTAL POWER ABSORBED		120 W
AVERAGE DAILY UNITS ELECTRICITY *		0.397 kWh

---

GROSS CAPACITY		
	Fridge	332 l
NET CAPACITY		
	Fridge	330 l

---

\* This figure is based on standard test results in accordance with European Standard EN 153.

Actual consumption will depend on how the appliance is used and where it is located.

# INSTALLATION

## Warning

IF YOU ARE DISCARDING AN OLD APPLIANCE THAT HAS A LOCK OR CATCH ON THE DOOR, YOU MUST ENSURE THAT IT IS MADE UNUSABLE TO PREVENT YOUNG CHILDREN BEING TRAPPED INSIDE.

Depending upon the position which you choose for your appliance, you may wish to reverse the way in which the door opens. To do this, refer to instructions on "Door reversal directions".

## Positioning

This appliance should only be installed at a location where the ambient temperature corresponds to the climate classification indicated on the rating plate, which is located at the left on the inside of the appliance.

The following table shows which ambient temperature is correct for each climate classification:

SN +10°C to + 32°C

N +16°C to + 32°C

ST +18°C to + 38°C

T +18°C to + 43°C

The appliance should be located in a dry atmosphere, out of direct sunlight and away from continuous heat and extreme temperature, e.g. not next to a boiler or radiator, or in a very cold room e.g. an outhouse. If these temperatures are exceeded i.e. warmer or colder, then the appliance may not operate correctly.

For building-in and door reversal instructions please refer to the relevant instructions on the following pages.

## Shelf holders

Your appliance is equipped with shelf retainers that make it possible to secure the shelves during transportation.

To remove them proceed as follows:

Move the shelf holders in the direction of the arrow, raise the shelf from the rear and push it forward until it is freed and remove the retainers.

## Important

It must be possible to disconnect the appliance from the mains power supply; the plug must therefore be easily accessible after installation.

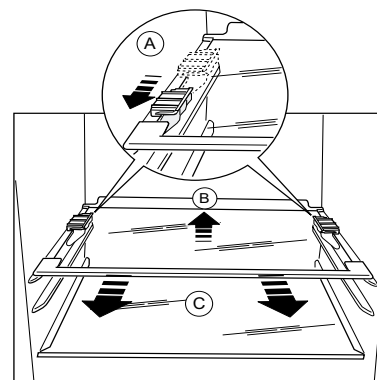

## **Electrical connections**

Any electrical work required to install this appliance should be carried out by a qualified electrician or competent person.

**WARNING: THIS APPLIANCE MUST BE EARTHED.**

**The manufacturer declines any liability should this safety measure not be observed.**

If the plug that is fitted to your appliance is not suitable for your socket outlet, it must be cut off and the appropriate plug fitted.

Remove the fuse from the cut off plug.

The cut off plug should then be disposed of to prevent the hazard of shocks in case it should be plugged into a 13amp socket in another part of your home.

## **Important**

The wires in the mains lead are coloured in accordance with the following code:

**Green and Yellow** - Earth

**Blue** - Neutral

**Brown** - Live

If you fit your own plug, the colours of the wires in the mains lead of your appliance may not correspond with the markings identifying the terminals in your plug, proceed as follows:

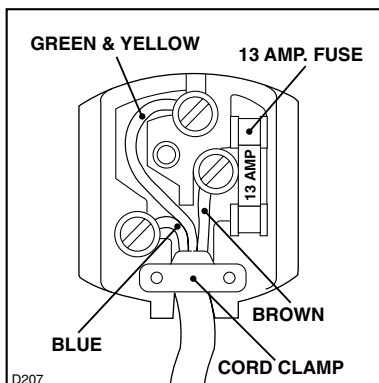

Connect the Green and Yellow (earth) wire to the terminal in the plug which is marked with the letter «E» or the earth symbol  or coloured green and yellow.

Connect the blue (neutral) wire to the terminal in the plug which is marked with the letter «N» or coloured black.

Connect the brown (live) wire to the terminal in the plug which is marked with the letter «L» or coloured red.

The plug moulded onto the lead incorporates a fuse. For replacement, use a 13amp BSI362 fuse. Only ASTA or BSI approved fuses should be used.

The plug must not be used if the fuse cover/carrier is lost. The cover/carrier is indicated by the coloured insert at the base of the plug.

A replacement cover/carrier must be obtained from your local Service Force Centre.

**This appliance complies with the E.E.C. Directive No. 87/308 of 2.6.87 relative to radio interference suppression.**

 This appliance complies with the following E.E.C. Directives:

- **73/23 EEC of 19.2.73** (Low Voltage Directive) and subsequent modifications;
- **89/336 EEC of 3.5.89** (Electromagnetic Compatibility Directive) and subsequent modifications.

## **i** Door Reversibility

**!** The appliance is supplied with the door opening to the right.

**For door opening in the opposite direction, perform the following actions prior to installation**

1. Unscrew the upper pin and remove the spacer
2. Remove the door.
3. Unscrew the lower pin and remove the spacer; replace them on the opposite side.
4. Reinsert the door and screw the pin and the spacer back in place on the opposite side.

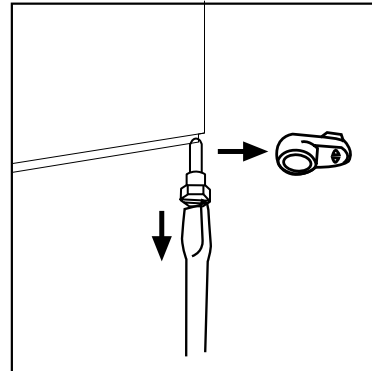
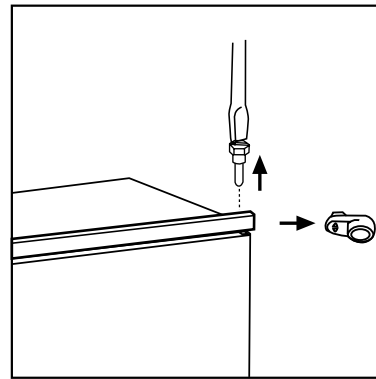

## **i** Instructions for totally built-in appliances

### Recess dimensions

Height	(1)	1780 mm
Depth	(2)	550 mm
Width	(3)	560 mm

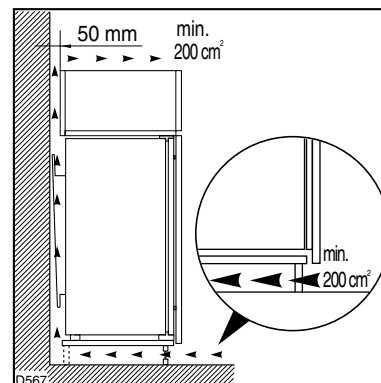

**The appliance's door has been locked in position for transport by means of pins on both sides. According to the door opening direction, remove relevant pins at the top and at the bottom.**

To ensure adequate ventilation, allow the clearances shown in figure.

Furthermore, it is necessary that the cabinet has a ventilation recess with the following dimensions:

depth	50 mm
width	540 mm

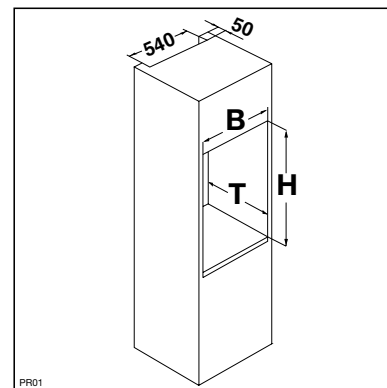

Drill the unit using a  $\varnothing 2.5$  mm drill (10 mm max. penetration);  
 Fix the square fitting to the appliance.

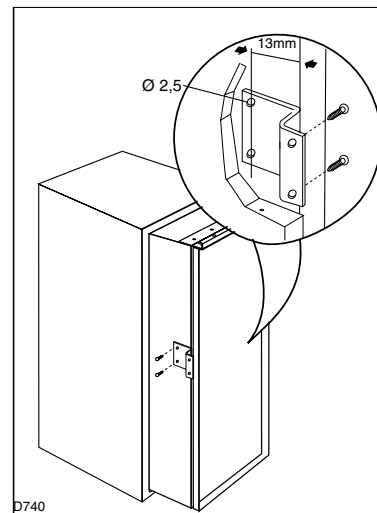

Fit the appliance in the niche by making sure that it stands against the interior surface of the unit on the side where the door hinges of the appliances are fitted. Insert the appliance until the upper strip butts up against the unit (1) and make sure that the lower hinge is in line with the surface of the unit (2).

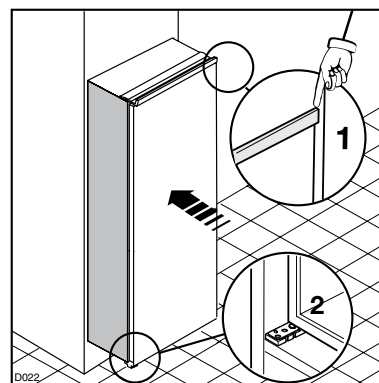

Fasten the appliance with 4 screws provided in the kit included with the appliance.  
 (I = short) (P = long)

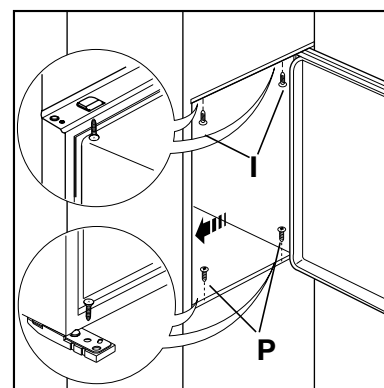

Apply the sealing strip pushing it between the refrigerator and the adjacent cabinet.

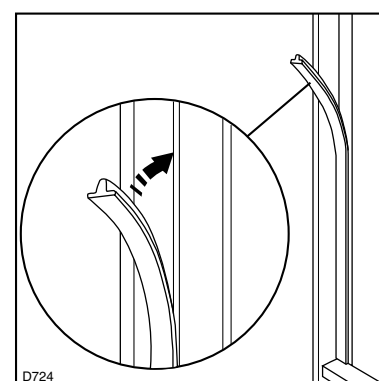



Apply covers (C-D) on joint cover lugs and into hinge holes.  
 Snap vent grille (B) and hinge cover (E) into position.

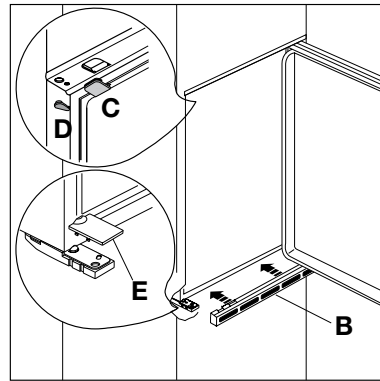

Separate parts Ha, Hb, Hc, Hd as shown in the figure.

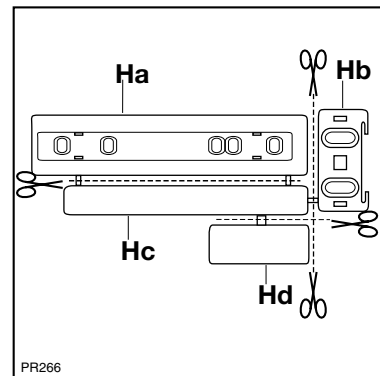

Place guide (Ha) on the inside part of the furniture door, as shown in the figure and mark the position of external holes. After having drilled holes, fix the guide with the screws supplied.

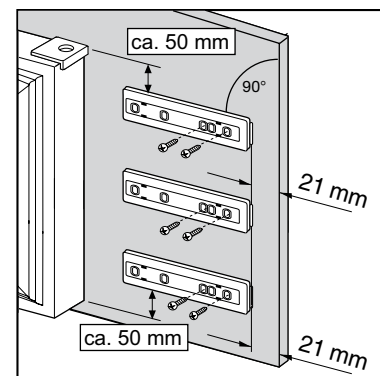

Fix cover (Hc) on guide (Ha) until it clips into place

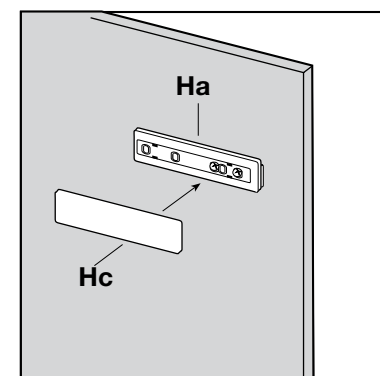

Open the appliance door and the furniture door at 90°. Insert the small square (Hb) into guide (Ha). Put together the appliance door and the furniture door and mark the holes as indicated in the figure. Remove the squares and drill holes with  $\varnothing 2$  mm at 8 mm from the outer edge of the door. Place the small square on the guide again and fix it with the screws supplied.

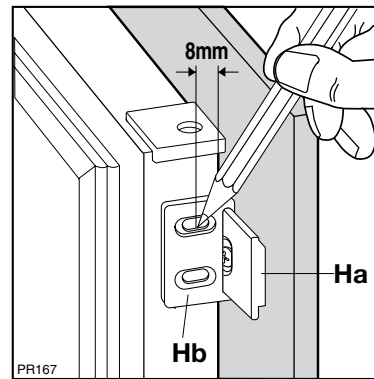

Should the lining up of the furniture door be necessary, use the clearance of slots.

At the end of operations, it is necessary to check if the door of the furniture closes properly.

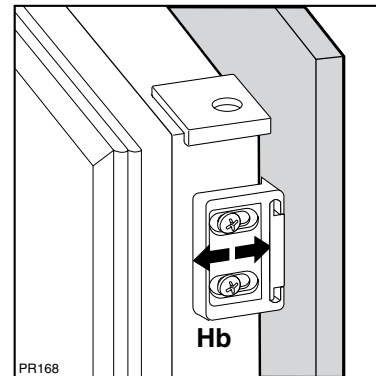

Fix cover (Hd) on guide (Hb) until it clips into place.

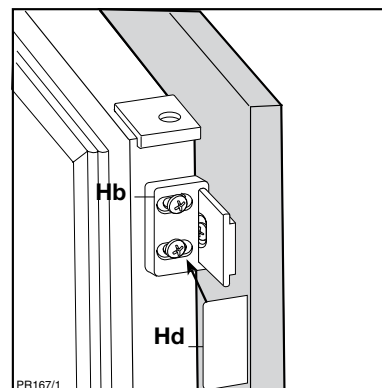



[www.electrolux.com](http://www.electrolux.com)

[www.electrolux.co.uk](http://www.electrolux.co.uk)