

Thinking of you
Electrolux

gebrauchsanleitung DE
instruction book GB

kühl - gefrierkombination
refrigerator- freezer combination

ERB 34001W



We were thinking of you
when we made this product

Welcome to the world of Electrolux

Thank you for choosing a first class product from Electrolux, which hopefully will provide you with lots of pleasure in the future. The Electrolux ambition is to offer a wide variety of quality products that make your life more comfortable. You find some examples on the cover in this manual. Please take a few minutes to study this manual so that you can take advantage of the benefits of your new machine. We promise that it will provide a superior User Experience delivering Ease-of-Mind. Good luck!

Before installing and using the appliance read this user's instruction book carefully. It contains safety precautions, hints, information and ideas. If the refrigerator is used in compliance with the instructions written, it will operate properly and provide you with greatest satisfaction.

The symbols below help you to find things more easily:



Safety precautions

Warnings and information at this symbol serve safety for you and your appliance.



Hints, useful information



Environmental information



Symbol for ideas

At this symbol ideas can be found according to food and its storing.



The symbol on the product or on its packaging indicates that this product may not be treated as household waste. Instead it shall be handed over to the applicable collection point for the recycling of electrical and electronic equipment. By ensuring this product is disposed of correctly, you will help prevent potential negative consequences for the environment and human health, which could otherwise be caused by inappropriate waste handling of this product. For more detailed information about recycling of this product, please contact your local city office, your household waste disposal service or the shop where you purchased the product.

Contents

| | |
|---|-----------|
| Important safety information | 35 |
| General safety precautions | 35 |
| Precautions for child safety | 36 |
| Safety precautions for installation | 36 |
| Safety precautions for isobutane | 36 |
| Instructions for the User | 37 |
| General information | 37 |
| Putting it into use | 37 |
| Controlling the temperature, setting | 37 |
| How to use the refrigerator | 38 |
| Storing in the refrigerator | 38 |
| Storage time and temperature of foods | 38 |
| Freezing | 39 |
| Storing in the freezer | 39 |
| Some useful information and advice | 40 |
| Hints and ideas | 41 |
| How to save energy | 41 |
| The appliance and environment | 41 |
| Maintenance | 41 |
| Defrosting | 41 |
| Regular cleaning | 43 |
| When the refrigerator is not in use | 43 |
| Trouble shooting | 43 |
| How to change the bulb | 43 |
| If something does not work | 43 |
| Instructions for the Installer | 46 |
| Technical data | 46 |
| Installing the appliance | 46 |
| Transportation, unpacking | 46 |
| Cleaning | 46 |
| Placement | 46 |
| Electrical connection | 50 |
| Storage time chart (1) | 51 |
| Storage time chart (2) | 52 |
| Warranty and service | 52 |
| Guarantee conditions | 52 |
| Service and spare parts | 52 |
| Guarantee/Customer Service | 53 |
| European Guarantee | 56 |

Important safety information



General safety precautions

- Keep these instructions and they should remain at the appliance when moving away or changing owner.
- This appliance is designed for storing food, domestic use according to these instructions only.
- **Specialised companies that are qualified to do so by the manufacturer must carry out service and repairs including repairing and changing the power cord.** Accessory parts supplied by them should be used only for repairing. Otherwise the appliance can be damaged or can cause other damage or injury.
- The appliance is out of circuit only in that case if the plug is removed from the socket. Before cleaning and maintenance always unplug it (do not get it by the cable). If the socket is difficult to reach, switch off the appliance by cutting off the current.
- Power cord must not be lengthened.
- **Make sure that the power plug is not squashed or damaged by the back of the fridge/freezer.**
 - A damaged power plug may overheat and cause a fire.
- **Do not place heavy articles or the fridge/freezer itself on the power cord.**
 - There is a risk of a short circuit and fire.
- **Do not remove the power cord by pulling on its lead, particularly when the fridge/freezer is being pulled out of its niche.**
 - Damage to the cord may cause a short-circuit, fire and/or electric shock.
- If the power cord is damaged, it must be replaced by a certified service agent or qualified service personnel.
- **If the power plug socket is loose, do not insert the power plug.**
 - There is a risk of electric shock or fire.
- Without the lamp cover of interior lighting you must not operate the appliance.
- When cleaning, defrosting, taking out frozen food or ice tray do not use sharp, pointed or hard devices, as they can cause damage to the appliance.
- Be careful not to allow liquids to the temperature control and lighting box.
- Ice and ice-cream can cause hurt if they are eaten immediately after removal from the frozen food compartment.
- After dissolving frozen food must not be refrozen, it must be used up as soon as possible.
- Store pre-packed frozen food in accordance with the frozen food manufacturer's instructions.
- You must not make defrosting faster with any electric heating appliance or chemicals.
- Do not put hot pot to the plastic parts.
- Do not store flammable gas and liquid in the appliance, because they may explode.
- Do not store carbonated drinks, bottled drinks and bottled fruits in the frozen food compartment.
- Check and clean the outlet of melting water coming during defrosting regularly - a label inside the appliance warns you for this. If it is clogged the melting water gathered can cause earlier failure.



Precautions for child safety

- Do not allow children to play with the packaging of the appliance. Plastic foil can cause suffocation.
- Adults must handle the appliance. Do not allow children to play with it or its controlling parts.
- If you are discarding the appliance pull the plug out of the socket, cut the connection cable (as close to the appliance as you can) and remove the door to prevent playing children to suffer electric shock or to close themselves into it.



Safety precautions for installation

- Put the appliance to the wall to avoid touching or catching warm parts (compressor, condenser) to prevent possible burn.
- When moving the appliance take care of the plug not to be in the socket.
- When placing the appliance take care not to stand it on the power cord.
- Adequate air circulation should be around the appliance, lacking this leads to overheating. To achieve sufficient ventilation follow the instructions relevant to installation.
- See chapter "Placement".



Safety precautions for isobutane

Warning

- The refrigerant of the appliance is isobutane (R600a) that is inflammable and explosive to a greater extent.
- Keep ventilation openings, in the appliance enclosure or in the built-in structure, clear of obstruction.
- Do not use mechanical devices or other means to accelerate the

defrosting process, other than those recommended by the manufacturer.

- Do not damage the refrigerant circuit.
- Do not use electrical appliances inside the food storage compartments of the appliance, unless they are of the type recommended by the manufacturer.



For the safety of life and property keep the precautions of these user's instructions as the manufacturer is not responsible for damages caused by omission.

Instructions for the User

General information

The official designation of the appliance is "refrigeratorfreezercombination with one motor compressor and freezer placed in the lower part". The appliance has - besides the general services- a freezer with its own door and is completely separated from the other unit.

According to this the appliance is suitable for storing frozen and deep-frozen food, freezing products in quantity given in the user's instructions at home and making ice. The appliance can meet the requirements of standards between different temperature limits according to the climate class.

The letter symbol for climate class can be found on the data label.

Putting it into use

Place the accessories into the appliance then plug to the mains socket.

The thermostat knob is on the light box in the refrigerator. You can switch the appliance on and set the temperature with it by turning the knob clockwise.

The next paragraph will give instructions for setting.

Controlling the temperature, setting

The thermostat interrupts the operation of the appliance automatically for more or less time depending on the setting then restarts it assuring the required temperature.

The closer it is set to maximum position the more intensive the refrigerating will be. When the thermostat knob is set to a medium position (between minimum and maximum), in the freezing compartment -18 °C, in the fresh food compartment +5 °C can be reached. Setting it to a medium position is adequate for everyday use.

The temperature coming about in the refrigerator is effected by not only the position of the thermostat but the ambient temperature, frequency of door openings and the quantity of food put into it newly, etc.

i In the maximum position - in case of increased demand e.g. during heatwaves - the compressor may operate continually. This does not cause damages to the appliance.

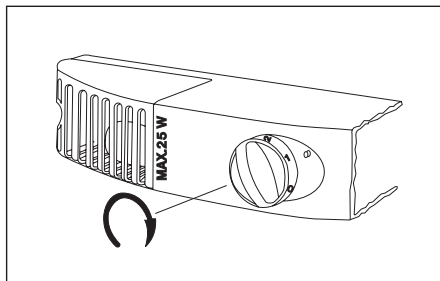

How to use the refrigerator

i For adequate cooling developing interior air circulation is necessary. For this reason you are asked not to cover the air circulation gaps behind the shelves (e.g. with tray etc.).

i Do not put hot food into the refrigerator. Allow it to reach room temperature naturally. In this way the unnecessary frost building up can be avoided.

i Foods can take over odours from each other. So it is essential to put foods in closed dishes or wrap them in cellophane, aluminium foil, grease-proof paper or cling film before placing them into the refrigerator. This way foods will keep their moisture e.g. vegetables will not dry out after some days.

Storing in the refrigerator

When placing the different kinds of food take into consideration the sketch below in figure:

1. Confectionery, ready-cooked foods, foods in dishes, fresh meat, cold cuts, drinks
2. Milk, dairy products, foods in dishes
3. Fruits, vegetables, salads
4. Cheese, butter
5. Eggs
6. Yoghurt, sour cream
7. Small bottles, soft drinks
8. Big bottles, drinks

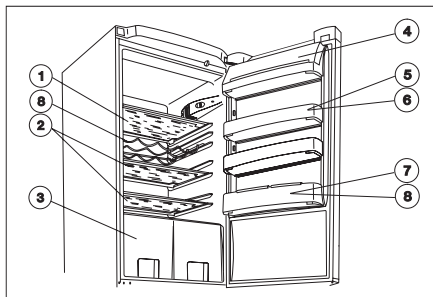

Storage time and temperature of foods

The storage time chart at the end of the instruction book gives information about storage time.

The storage time can not be determined exactly in advance, as it depends on the freshness and handling of the cooled food. That is why the storage time made known is only informative.

If you do not want to use up deep-frozen foods bought immediately they can be stored for about 1 day (until dissolving) in the refrigerator.

Freezing

The appliance can be used to freeze fresh food of quantity specified on the data label. Freezing different products should always be done after proper preparing as follows.

Set the thermostat knob to a medium position.

Put the previously frozen food - or some of it - to the basket or baskets. Put the fresh food into the freezing compartment, leaving enough space for airflow. If there is some previously frozen food left in the freezing compartment, put this food into the back of the compartment avoiding the contact between the fresh food and the already frozen food.

Run the appliance this way for 24 hours.

After 24 hours set the thermostat knob according to your choice or leave it in a medium position, which is in general appropriate for everyday cooling needs.

 Setting the thermostat knob to a higher (e.g. maximum) position is not recommended. Although doing so would make the freezing time shorter, on the other hand the temperature of the fridge compartment may go permanently below 0 °C, what yields freezing the food and drinks stored there.

 **Never freeze food in bigger quantity than given in the 'Technical data' at the same time, otherwise freezing will not be thorough and after dissolving various deterioration may take place (losing taste and aroma, lysing, etc.).**

 Do not make ice during freezing preferably, because making ice reduces freezing capacity.

Storing in the freezer

It is practical to replace frozen products into the basket(s) after freezing has finished. Doing this you could make room in the freezing compartment for another freezing. Intermediate freezing does not deteriorate foods already stored.

In large quantities of food are to be stored, remove the baskets except the lowermost one from appliance and place food on the cooling surface.

 Do not forget to keep to the storage time given on the packaging of frozen products if you buy them frozen. To store home-frozen products see the storing instructions placed in the door of the freezer. Symbols signify the various foods, numbers mean maximum storing time given in months.

 It is safe to store quick-frozen, frozen foods only if they have not dissolved even for a short time until placing them into the freezer. If the deep-frozen food has already dissolved, refreezing is not recommended, it has to be used up as soon as possible

i Some useful information and advice

- The variable shelves are worth paying attention to, which increases the usability of the fresh food compartment considerably. Rearranging the shelves is also possible when the door is open at an angle of 90°.
- After opening and closing the door of freezer vacuum will rise inside the appliance because of the low temperature. So wait 2-3 minutes after closing the door - if you want to open it again - while inner pressure equalises.
- Take care of opening the freezer at a position of thermostatic control so that the inside temperature can never be warmer than -18°C.
- It is practical to make sure of faultless operation of the appliance daily so as to notice possible failure in time and prevent deterioration of frozen foods.
- Normal operating sounds:
 - A thermostat controls the compressor and you will hear a faint click when thermostat cuts in and out.
 - You may hear faint gurgling or bubbling sound when the refrigerant is pumped through the coils at the rear, to the cooling plate/evaporator.
 - When the compressor is on, the refrigerant is being pumped round and you will hear a whirring sound or pulsating noise from the compressor.
- The fridge evaporator (this part cool down the fridge section) is foamed into the cabinet. The temperature of

this part changing during its work, and parallel with this its dimensions are slightly changing, too. These changes might cause a cracking noise, which is a natural, harmless phenomenon.

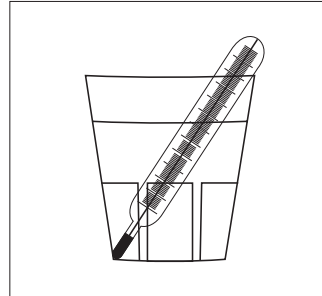

- Should you want to check the temperature of food stored in the refrigerator, set the thermostat knob into a medium position, place a glass of water centrally in the cabinet, and put a proper thermometer with an accuracy of +/- 1°C into it. If after 6 hours you measure a value between +3°C and +8°C, the refrigerator works properly. The measuring shall be performed under steady-stated conditions (without changing the load).
- If the freezer temperature is measured using a thermometer, put it between the products since this will reflect the real temperature in the frozen products.

Hints and ideas

In this chapter practical hints and ideas are given about how to use the appliance to reach maximum energy saving and there is environmental information about the appliance as well.



How to save energy

- Avoid putting the appliance in a sunny place and near anything that gives off heat.
- Be sure that the condenser and the compressor are well ventilated. Do not cover the sections where ventilation is.
- Wrap products in tightly closing dishes or cling film to avoid building up unnecessary frost.
- Do not leave the door open longer than necessary and avoid unnecessary openings.
- Put warm foods into the appliance only when they are at room temperature.
- Keep the condenser clean.



The appliance and environment

This appliance does not contain gasses which could damage the ozone layer, in either its refrigerant circuit or insulation materials. The appliance shall not be discarded together with the urban refuse and rubbish. Avoid damaging the cooling unit, especially at the rear near the heat exchanger. Information on your local disposal sites may be obtained from your municipal authorities.

The materials used on this appliance marked with the symbol  are recyclable.

Maintenance

Defrosting

Bleeding part of the moisture of cooling chambers in form of frost and ice goes with the operation of the appliance.

Thick frost and ice has an insulating effect, so it reduces cooling efficiency as the temperature increases in the cooling chambers, they need more energy.

At this type of appliance defrosting the cooling surface of the refrigerator is automatic without any external intervention. The thermostatic control interrupts the operation of compressor at regular intervals for more or less time - during this cooling is interrupted - the temperature of the cooling surface goes above 0 °C due to interior heating load of the compartment, so defrosting occurs. When the surface temperature of the cooling surface has reached +3 - +4 °C the thermostatic control restarts operation of the system.

Melting water flows through defrost water outlet leaded through the back into the evaporator tray maintained on the top of

compressor and evaporates due to its warmth.

⚠ Check and clean the outlet of melting water coming during defrosting regularly - a label inside the appliance warns you for this. If it is clogged the melting water gathered can cause earlier failure as it can go to the insulating of the appliance.

Clean the melting water outlet with the supplied pipe scraper that can be seen in the figure. The pipe scraper has to be stored in the outlet.

The most typical case of clogging up in the melting water outlet when you put food wrapped in some paper into the appliance and this paper contacts back plate of the refrigerator and freezes to it. If you remove the food right at this moment the paper will tear and it can cause clogging up in the outlet by getting into it. So you are asked to be careful - because of the above - when placing foods wrapped in paper into the appliance.

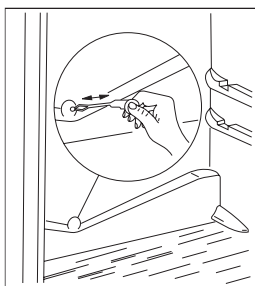

i In case of increased demand e.g. during heatwaves, the refrigerator temporarily happens to operate constantly - during this the automatic defrosting does not work.

Remaining small ice and frost stains on back plate of the refrigerator after defrosting period is not abnormal.

The freezer can not be equipped with automatic defrosting set since the deep-frozen and frozen foods do not endure melting temperature.

When small frost and ice occurs scrape off and remove frost and ice coating with the supplied plastic scraper.

When ice coating is so thick that it cannot be removed with the plastic scraper, the cooling gill have to be defrosted. Frequency of defrosting depends on usage (generally 2-3 times a year).

Take the frozen foods out of the appliance, and put them into a basket lined with paper or cloth. Store them in a possibly cool place or replace them into another refrigerator.

Pull out the mains plug from the mains socket, so both parts of the appliance are out of operation.

Open the doors of both parts of the appliance and clean the refrigerator according to 'Regular cleaning'. Maintain and clean the freezer as following:

Sweep off the melting water with a cloth or sponge in direction of sides of the cooling plates. The melting water swept down gathers in the outlet channel practically formed in the bottom of the appliance and can be removed according to figure.

Put an adequately high bowl or dish under the outlet.

The bowl in figure is not a piece of accessories to the appliance!

Wipe the surfaces after defrosting and leading the water out.

Put the mains plug into the mains socket and put foods taken out back to their places. It is recommended to operate the appliance at the highest position of the thermostatic control for some hours so that it can reach the sufficient storing temperature as soon as possible.

Regular cleaning

It is recommended to wash the inside of the refrigerator in 3-4 weeks time using lukewarm water then wipe it (it is practical to clean the inside of the freezer and defrost it at a time).

Household cleaner or soap must not be used.

After breaking the circuit wash the appliance with lukewarm water then wipe it. Clean the door gasket with clean water. After cleaning apply voltage to the appliance.

It is recommended to remove the dust and dirt collected on the back of the refrigerator and the condenser and to clean the evaporative tray on top of the compressor once or twice a year.

When the refrigerator is not in use

In case the appliance will not be used for a long time follow these steps:

Break the circuit of the appliance.

Remove foods from the refrigerator.

Clean it as written before.

Leave the door open to avoid a build up of air inside.

Trouble shooting

How to change the bulb

Should the light fail to work you can change it as below: Break the circuit of the appliance. Press the rear hook (1) and at the same time slide the cover

in the direction indicated by the arrow (2).

So the bulb can be replaced. (Bulb type: T 25 230-240 V, 25 W, E 14

thread) After changing the bulb replace the cover, snap it in place and apply voltage to the appliance.

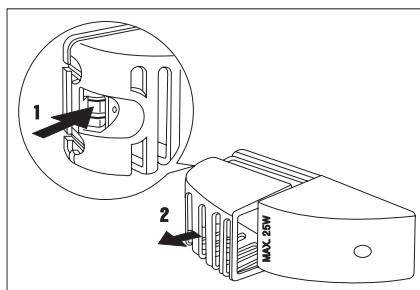

If something does not work

During operation of the appliance some smaller but annoying trouble can often occur, which does not require calling a technician out. In the following chart information is given about them to avoid unnecessary charges on service.

We draw your attention that operation of appliance goes with certain sounds (compressor- and circulating sound). This is not trouble, but means normal operation.



We draw it to your attention again that the appliance operates discontinuously, so the stopping of compressor does not mean being non-current. That is why you must not touch the electrical parts of the appliance before breaking the circuit.

| Problem | Possible cause | Solution |
|--------------------------------------|--|--|
| It is too warm in the refrigerator. | <p>Thermostatic control can be set wrongly.</p> <p>If products are not cold enough or placed wrongly.</p> <p>The door does not close tightly or it is not shut properly.</p> | <p>Set the thermostat knob to higher position.</p> <p>Place the products to the appropriate place.</p> <p>Check if the door closes well and the gasket is unhurt and clean.</p> |
| It is too warm in the freezer. | <p>Thermostatic control can be set wrongly.</p> <p>The door does not close tightly or it is not shut properly.</p> <p>Products in big quantity to be frozen were put in.</p> <p>Products to be frozen are placed too closely to each other.</p> | <p>Set the thermostat knob to higher position.</p> <p>Check if the door closes well and the gasket is unhurt and clean.</p> <p>Wait some hours and then check the temperature again.</p> <p>Place the products in a way so that cold air could circulate among them.</p> |
| There are too much frost and ice. | <p>Products are not wrapped properly.</p> <p>Doors are not shut properly or do not close tightly.</p> <p>The thermostatic control can be set wrongly.</p> <p>The thermostatic control is set wrongly.</p> | <p>Wrap the products better.</p> <p>Check if the doors close well and the gaskets are unhurt and clean.</p> <p>Set the thermostat knob to a position that gives higher temperature.</p> |
| The compressor operates continually. | <p>Doors are not shut properly or do not close tightly.</p> <p>Products in big quantity to be frozen were put in.</p> <p>Too warm food was put in.</p> <p>The appliance is in too warm place.</p> <p>Plug is not connected to the mains socket properly.</p> | <p>Check if the doors close well and the gaskets are unhurt and clean.</p> <p>Wait some hours and then check the temperature again.</p> <p>Put food at max. room temperature.</p> <p>Try to reduce the temperature in the room where the appliance stands.</p> <p>Connect the mains plug properly.</p> |

| | | |
|--|--|---|
| The appliance does not work at all. Neither cooling, nor lighting works. | The fuse burnt out. The thermostatic control is not on. There is no voltage in the mains socket. (Try to connect another appliance into it.) | Change the fuse. Start the appliance according to instructions in chapter 'Putting it into use'. Call an electrician. |
| The appliance is noisy. | The appliance is not supported properly. | Check if the appliance stands stable (all the four feet should be on the floor). |

Inasmuch as the advice does not lead to result, call the nearest brand-mark service.

Instructions for the Installer

Technical data

| Model | ERB 34001W |
|--|-----------------------------------|
| Gross capacity (l) | Freezer: 110 Refrigerator: 225 |
| Net capacity (l) | Freezer: 92 Refrigerator: 223 |
| Width (mm) | 595 |
| Height (mm) | 1750 |
| Depth (mm) | 632 |
| Energy consumption (kWh/24h) (kWh/year) | 0,93 339 |
| Energy class, according to EU standards | A |
| Freezing capacity (kg/24h) | 4 |
| Rising time (h) | 20 |
| Rated current (A) | 0,9 |
| Weight (kg) | 66 |
| Number of compressors | 1 |

Installing the appliance

Transportation, unpacking

 It is recommended to deliver the appliance in original packaging, in vertical position considering the protective warning on packaging.

After each transportation the appliance must not be switched on for approx. 2 hours.

Unpack the appliance and check if there are damages on it. Report possible damages immediately to the place you bought it. In that case retain packaging.

Cleaning

Remove every adhesive tape, which ensure the parts not to move in the appliance.

Wash the inside of the appliance using lukewarm water and mild detergent. Use soft cloth.

After cleaning wipe out the inside of the appliance.

Placement

The ambient temperature has an effect on the energy consumption and proper operation of the appliance. When placing, take into consideration that it is practical to operate the appliance between ambient temperature limits according to the climate class that is given in the chart below and can be found in the data label.

| Class of climate | Ambient temperature |
|------------------|---------------------|
| SN | +10 ... +32 °C |
| N | +16 ... +32 °C |
| ST | +18 ... +38 °C |

If the ambient temperature goes below the lower data the temperature of the cooling compartment can go beyond the prescribed temperature.

If the ambient temperature goes beyond the upper data this means longer operating time of the compressor, breakdown in the automatic defrosting increasing temperature in the cooling compartment or increasing energy consumption.

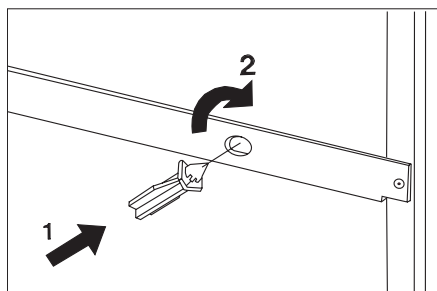

Mount the spacers supplied in the plastic bag of the accessories. Hold the spacer as shown on the Fig., knock it home, then turn it by 90° (Into the oval holes of back side of the appliance.)

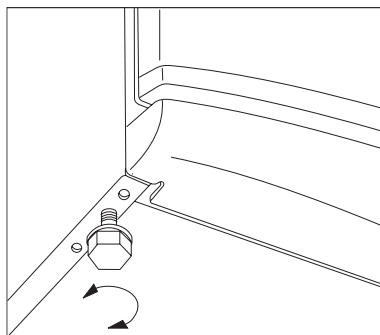

Slacken the screws and insert the spacer under the screw head, the re-tighten the screws.

When placing the appliance ensure that it stands level. This can be achieved by two adjustable feet at the bottom in front.

Do not stand the appliance on a sunny place or close to a radiator or cooker.

If it is unavoidable because of furnishing and the appliance has to be stood near a cooker take these minimum distances into consideration:

- In case of gas or electric cooker 3 cm must be left, when it is less put a 0,5-1 cm non-flam insulation between the two appliances.
- In case of oil or coal-fired stove the distance must be 30 cms since they give off more heat.

The refrigerator is designed to operate when it is totally pushed to the wall.



When placing the refrigerator keep minimal distances recommended in figure.

A : placing it under a wall-cupboard

B : placing it freely

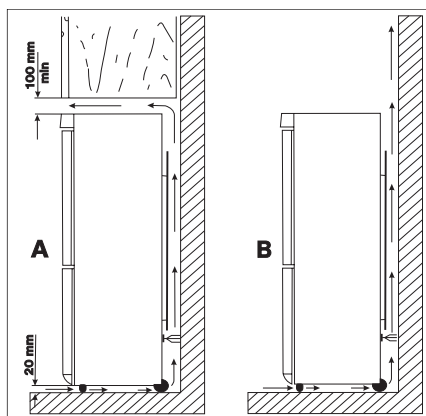

Door reversal

Should the location demand it, the opening direction of the door can be changed.

The appliances are delivered with the door opening to the right.

Carry out the steps as per the pictures and the instructions.

- We recommend that you have another person to help you who can safely hold the doors of the appliance secure.
- Disconnect the appliance from the electrical supply.

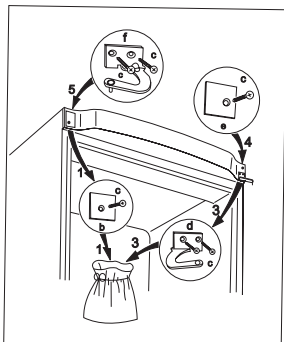

Fig. 1

- Open the door of the fridge, dismantle the top cover (j) by removing the 2 screws (a), then close the door (Fig. 2).
- Move the panel (g) from one side of the top cover (2) to the other (Fig. 2).

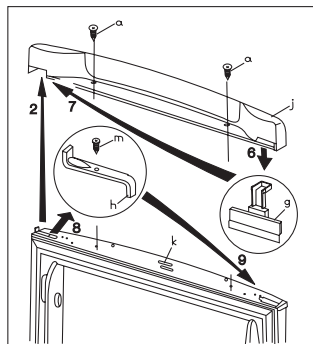

Fig. 2

- Unscrew the 2 screws (c), remove the door mount at the top right-hand side (d), and unscrew the screw on the other side (c), remove the panel (b) and place in an empty plastic bag.
- Lift the fridge door up slightly and remove.
- Unscrew the screw (m), remove the door stopper (h) and attach reversed on the other side (Fig. 2).

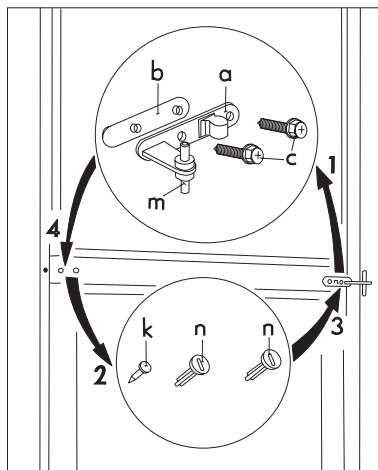

Fig. 3

- Remove double door mount (a, b, c) from the body of the appliance in steps. Please make sure the plastic

spacer (b) under the door mount is also removed (Fig. 3).

- Lift the freezer door up slightly and remove.
- Remove stops in both doors (t, z) (Fig. 5).
- Lift out the insert for the lower covering grid (e) using a screw driver (Fig. 4).
- Unscrew the bottom door retaining pin for the freezer door (h, f) and then screw in on the other side. Don't forget the spacer (h) (Fig. 4).
- Insert the insert for the lower covering grid (e) on the other side.

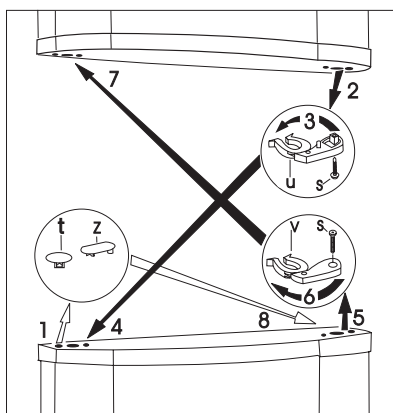

Fig.4

- Remove the left-hand cover pin of the double door mount (3 pieces, n, k) and move to the other side (Fig. 3).
- Disassemble the door locking elements (u, v) by unscrewing the screw (s) (Fig. 3).
- Reverse the door locking elements (u, v), move to the other side of the other door and fix by screwing in the screw (s).
- Re-insert the stoppers (t, z) on the other side of the doors.

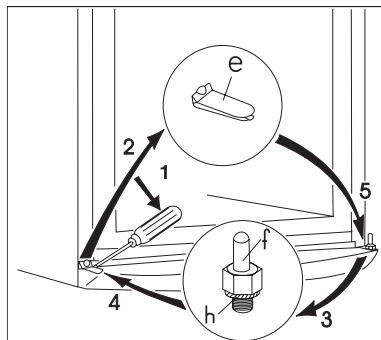

Fig. 5.

- Fit the pin of the double door mount (m) into the left-hand hole of the freezer door (Fig. 3).
- Place the freezer door on the lower door retaining pin (f) (Fig. 4).
- Open doors and fix the double door mount with 2 screws (c) on the left-hand side. Don't forget the plastic spacer under the door (b) as well. The edges of the doors must run parallel to the side edge of the appliance.
- Place the fridge door on the double door retaining pin.
- Remove the top left-hand side door mount (f) and the panel (c) from the plastic bag and attach using the screws (c) (Fig. 1).
- Open the fridge door, attach the top cover (j) using 2 screws (a); at the same time pay attention to the repositioning of the magnet (k), then close the door (Fig. 2).
- Put the appliance into position, make adjustments if not horizontal and connect to the electrical supply.

If you do not want to carry out these steps yourself, please contact the nearest branded service point. Technicians will make a charge for door reversal.

Electrical connection

This refrigerator is designed to operate on a 230 V AC (~) 50 Hz supply.

The plug must be put into a socket with protective contact. If there is no such, it is recommended to get an electrician to fit an earthed socket in compliance with standards near the refrigerator.

C E This appliance complies with the following E.E.C. Directives:

- 73/23 EEC of 19.02.73 (Low Voltage Directive) and subsequent modifications,
- 89/336 EEC of 03.05.89 (Electromagnetic Compatibility Directive) and subsequent modifications.

Storage time chart (1)

Time and method of storage of fresh foods in the refrigerator

| Foods | Storage time in days | | | | | | | Method of packaging |
|--|----------------------|---|---|---|---|---|---|--|
| | 1 | 2 | 3 | 4 | 5 | 6 | 7 | |
| Raw meat | X | X | x | x | x | | | cling film, airtight |
| Cooked meat | X | X | X | x | x | x | | dish covered |
| Roasted meat | X | X | X | x | x | | | dish covered |
| Raw minced meat | X | | | | | | | dish covered |
| Roasted minced meat | X | X | x | x | | | | dish covered |
| Cold cuts, Vienna sausage | X | X | x | x | | | | cling film, cellophane, grease-proof paper |
| Fresh fish | X | x | x | | | | | cling film, airtight |
| Cooked fish | X | X | x | x | | | | dish covered |
| Fried fish | X | X | x | x | x | | | dish covered |
| Tinned fish, open | X | x | x | | | | | dish covered |
| Fresh chicken | X | X | X | x | x | x | | cling film, airtight |
| Fried chicken | X | X | X | x | x | x | | dish covered |
| Fresh hen | X | X | x | x | x | | | cling film, airtight |
| Boiled hen | X | X | x | x | x | | | dish covered |
| Fresh duck, goose | X | X | X | x | x | x | | cling film, airtight |
| Roasted duck, goose | X | X | X | X | x | x | x | dish covered |
| Butter unopened | X | X | X | X | X | X | X | original packaging |
| Butter opened | X | X | x | x | x | x | x | original packaging |
| Milk in a plastic bag | X | X | X | x | x | | | original packaging |
| Cream | X | X | x | x | | | | plastic box |
| Sour cream | X | X | X | X | x | x | x | plastic box |
| Cheese (hard) | X | X | X | X | X | X | X | aluminium foil |
| Cheese (soft) | X | X | X | X | x | x | x | cling film |
| Curds | X | X | X | X | x | x | x | cling film |
| Egg | X | X | X | X | X | X | X | |
| Spinach, sorrel | X | X | x | x | | | | cling film |
| Green peas, green beans | X | X | X | X | x | x | x | cling film |
| Mushroom | X | X | x | x | x | | | cling film |
| Carrot, roots | X | X | X | X | X | X | X | cling film |
| Bell-pepper | X | X | x | x | x | | | cling film |
| Tomato | X | X | X | X | X | X | X | cling film |
| Cabbage | X | X | X | X | X | x | x | cling film |
| Quickly rotting fruits (strawberry, raspberry, etc.) | X | X | X | x | x | | | cling film |
| Other fruits | X | X | X | X | x | x | x | cling film |
| Tinned fruits opened | X | X | X | x | x | | | dish covered |
| Cakes filled with cream | X | X | x | x | | | | dish covered |

Notation:

X usual storage time

x possible storage time (concerns to really fresh product only)

Storage time chart (2)

Storage time of deep-frozen and frozen products

| Foods | In the fresh food compartment +2 - +7°C | In the **** frozen food compartment -18°C |
|---|---|---|
| Vegetables: green beans, green peas, mixed vegetables, marrow, corn, etc. | 1 day | 12 months |
| Ready-cooked foods: vegetable dish, trimmings, with meat, etc. | 1 day | 12 months |
| Ready-cooked foods: sirloin steaks, stew from knuckle of ham, meat from pig pudding, etc. | 1 day | 6 months |
| Foods from potatoes, pasta: mashed potato, gnocchi, dumpling, pasta filled with jam, chips | 1 day | 12 months |
| Soups: meat-broth, soup from green beans, soup from green peas, etc. | 1 day | 6 months |
| Fruits: sour cherry, cherry, gooseberry, fruit cream, mashed maroon | 1 day | 12 months |
| Meat: chicken, duck, goose fillets, tuna fish | 1 day 1 day | 5 months 6 months |
| Popsicle, ice-cream | 1 day | 3 weeks |

Warranty and service

Guarantee conditions

Service and spare parts

If calling the service is unavoidable, announce the trouble at a brand-mark service nearest to your place.

When announcing the appliance has to be identified according to its data label.

The data label of the appliance is stuck to the wall of the interior beside the vegetable box in the fresh food compartment in the bottom on the left side. All necessary data are there which

are needed to the service announcement (type, model, serial number, etc.). Note here the data from the data label of your appliance:

| | |
|-------------------|--|
| Model | |
| Product No. | |
| Serial No. | |
| Date of purchase: | |

Guarantee/Customer Service

Belgium

DECLARATION OF GUARANTEE TERMS.

Our appliances are produced with the greatest of care. However, a defect may still occur.

Our consumer services department will repair this upon request, either during or after the guarantee period. The service life of the appliance will not, however, be reduced as a result.

This declaration of guarantee terms is based on European Union Directive 99/44/EC

and the provisions of the Civil Code. The statutory rights that the consumer has under this legislation are not affected by this declaration of guarantee terms.

This declaration does not affect the vendor's statutory warranty to the end user. The appliance is guaranteed within the context of and in adherence with the following terms:

1. In accordance with provisions laid down in paragraphs 2 to 15, we will remedy free of charge any defect that occurs within 24 months from the date the appliance is delivered to the first end user.

These guarantee terms do not apply in the event of use for professional or equivalent purposes.

2. Performing the guarantee means that the appliance is returned to the condition it was in before the defect occurred. Defective parts are replaced or repaired. Parts replaced free of charge become our property.
3. So as to avoid more severe damage, the defect must be brought to our attention immediately.

4. Applying the guarantee is subject to the consumer providing proof of purchase showing the purchase and/or delivery date.
5. The guarantee will not apply if damage caused to delicate parts, such as glass (vitreous ceramic), synthetic materials and rubber, is the result of inappropriate use.
6. The guarantee cannot be called on for minor faults that do not affect the value or the overall reliability of the appliance.
7. The statutory warranty does not apply when defects are caused by:
 - a chemical or electrochemical reaction caused by water,
 - abnormal environmental conditions in general,
 - unsuitable operating conditions,
 - contact with harsh substances.
8. The guarantee does not apply to defects due to transport which have occurred outside of our responsibility. Nor will the guarantee cover those caused by inadequate installation or assembly, lack of maintenance or failure to respect the assembly instructions or directions for use.
9. Defects that result from repairs or measures carried out by people who are not qualified or expert or defects that result from the addition of non-original accessories or spare parts are not covered by the guarantee.
10. Appliances that are easy to transport may be delivered or sent to the consumer services department. Home repairs are only anticipated for bulky appliances or built-in appliances.

11. If the appliances are built-in, built-under, fixed or suspended in such a way that removing and replacing them in the place where they are fitted takes more than half an hour, the costs that result therefrom will be charged for. Connected damage caused by these removal and replacement operations will be the responsibility of the user.

12. If, during the guarantee period, repairing the same defect repeatedly is not conclusive, or if the repair costs are considered disproportionate, in agreement with the consumer, the defective appliance may be replaced with another appliance of the same value.

In this event, we reserve the right to ask for a financial contribution calculated according to the length of time it has been used.

13. A repair under guarantee does not mean that the normal guarantee period will be extended nor that a new guarantee period begins.

14. We give a twelve month guarantee for repairs, limited to the same defect.

15. Except in the event where liability is legally imposed, this declaration of guarantee terms excludes any compensation for damage outside the appliance for which the consumer wishes to assert his rights. In the event of legally admitted liability, compensation will not exceed the purchase price paid for the appliance.

These guarantee terms are only valid for appliances purchased and used in Belgium.

For exported appliances, the user must first make sure that they satisfy the technical conditions (e.g.: voltage, frequency, installation instructions, type of gas, etc.) for the

country concerned and that they can withstand the local climatic and environmental conditions. For appliances purchased abroad, the user must first ensure that they meet the qualifications required in Belgium. Non-essential or requested adjustments are not covered by the guarantee and are not possible in all cases.

Our consumer services department is always at your disposal, even after the guarantee period has expired.

Address for our consumer services department:**Belgium**

| | Tel.: | Fax.: |
|--|--------------|--------------|
| Electrolux Home | | |
| Products Belgium Consumer services | 02/363.04.44 | 02/363.04.00 |
| ELECTROLUX SERVICE | | 02/363.04.60 |
| Bergensesteenweg 719 | | |
| 1502 Lembeek | | |
| E-mail: consumer.services@electrolux.be | | |
| Luxembourg | | |

| | Tel.: | Fax.: |
|--|-----------------|-------------------|
| Grand-Duché de Luxembourg | | |
| ELECTROLUX HOME | | |
| PRODUCTS Consumer services | 00 352 42 431-1 | 00 352 42 431-360 |
| Rue de Bitbourg. 7 | | |
| L-1273 Luxembourg-Hamm | | |
| E-mail: consumer-service.luxembourg@electrolux.lu | | |

EUROPEAN GUARANTEE

This appliance is guaranteed by Electrolux in each of the countries listed at the back of this user manual, for the period specified in the appliance guarantee or otherwise by law. If you move from one of these countries to another of the countries listed, the appliance guarantee will move with you subject to the following qualifications:-

- The appliance guarantee starts from the date you first purchased the appliance which will be evidenced by production of a valid purchase document issued by the seller of the appliance.
- The appliance guarantee is for the same period and to the same extent for labour and parts as exists in your new country of residence for this particular model or range of appliances.
- The appliance guarantee is personal to the original purchaser of the appliance and cannot be transferred to another user.
- The appliance is installed and used in accordance with instructions issued by Electrolux and is only used within the home, i.e. is not used for commercial purposes.
- The appliance is installed in accordance with all relevant regulations in force within your new country of residence.

The provisions of this European Guarantee do not affect any of the rights granted to you by law.



| | | |
|-----------------------------|---------------------|---|
| Albania | +35 5 4 261 450 | Rr. Pjeter Bogdani Nr. 7 Tirane |
| België/Belgien | +32 2 363 04 44 | Bergensesteenweg 719, 1502 Lembeek |
| Česká republika | +420 2 61 12 61 12 | Budějovická 3, Praha 4, 140 21 |
| Danmark | +45 70 11 74 00 | Sjællandsgade 2, 7000 Fredericia |
| Deutschland | +49 180 32 26 622 | Muggenhofer Str. 135, 90429 Nürnberg |
| Eesti | +37 2 66 50 030 | Mustanäe tee 24, 10621 Tallinn |
| España | +34 902 11 63 88 | Carretera M-300, Km. 29,900 Alcalá de Henares Madrid |
| France | www.electrolux.fr | |
| Great Britain | +44 8705 929 929 | Addington Way, Luton, Bedfordshire LU4 9QQ |
| Hellas | +30 23 10 56 19 70 | 4, Limnou Str., 54627 Thessaloniki |
| Hrvatska | +385 1 63 23 338 | Slavonska avenija 3, 10000 Zagreb |
| Ireland | +353 1 40 90 753 | Long Mile Road Dublin 12 |
| Italia | +39 (0) 434 558500 | C.so Lino Zanussi, 26 - 33080 Porcia (PN) |
| Latvija | +37 17 84 59 34 | Kr. Barona iela 130/2, LV-1012, Rīga |
| Lietuva | +370 5 2780609 | Verkių 29, LT-09108 Vilnius |
| Luxembourg | +35 2 42 43 13 01 | Rue de Bitbourg, 7, L-1273 Hamm |
| Magyarország | +36 1 252 1773 | H-1142 Budapest XIV, Erzsébet királyné útja 87 |
| Nederland | +31 17 24 68 300 | Vennootsweg 1, 2404 CG - Alphen aan den Rijn |
| Norge | +47 81 5 30 222 | Risløkkvn. 2, 0508 Oslo |
| Österreich | +43 18 66 400 | Herziggasse 9, 1230 Wien |
| Polska | +48 22 43 47 300 | ul. Kolejowa 5/7, Warsaw |
| Portugal | +35 12 14 40 39 39 | Quinta da Fonte - Edificio Gonçalves Zarco - Q. 35 -2774-518 Paço de Arcos |
| Romania | +40 21 451 20 30 | Str. Garii Progresului 2, S4, 040671 RO |
| Schweiz - Suisse - Svizzera | +41 62 88 99 111 | Industriestrasse 10, CH-5506 Mägenwil |
| Slovenija | +38 61 24 25 731 | Tržaška 132, 1000 Ljubljana |
| Slovensko | +421 2 43 33 43 22 | Electrolux Slovakia s.r.o., Electrolux Domáce spotrebiče SK, Seberniho 1, 821 03 Bratislava |
| Suomi | +35 8 26 22 33 00 | Konepajantanta 4, 28100 Pori |
| Sverige | +46 (0)771 76 76 76 | Electrolux Service, S:t Göransgatan 143, S-105 45 Stockholm |
| Türkiye | +90 21 22 93 10 25 | Tarlabasi caddesi no : 35 Taksim Istanbul |
| Россия | +7 095 937 7837 | 129090 Москва, Олимпийский проспект, 16, БД "Олимпик" |



www.electrolux.com
www.electrolux.de