

# KENWOOD

## KDC-X679 KDC-MP6025 KDC-MP625

CD-RECEIVER

### INSTRUCTION MANUAL

KENWOOD CORPORATION



**Take the time to read through this instruction manual.  
Familiarity with installation and operation procedures will help you  
obtain the best performance from your new CD-receiver.  
For your records**

Record the serial number, found on the back of the unit, in the spaces designated on the warranty card, and in the space provided below. Refer to the model and serial numbers whenever you call upon your KENWOOD dealer for information or service on the product.

Model KDC-X679/MP6025/MP625 Serial number \_\_\_\_\_

# Contents

---

<b>▲Warning</b>	<b>3</b>	<b>HD Radio control features</b>	<b>24</b>
<b>Safety precautions</b>	<b>4</b>	Tuning	
<b>Notes</b>	<b>6</b>	<b>Menu system</b>	<b>25</b>
<b>About CDs</b>	<b>7</b>	Menu System	
<b>Notes on playing MP3/WMA</b>	<b>8</b>	Security Code	
<b>General features</b>	<b>10</b>	Touch Sensor Tone	
Power		Manual Clock Adjustment	
Selecting the Source		DSI (Disabled System Indicator)	
Volume		Selectable Illumination	
Attenuator		Dimmer	
System Q		System Q Setting	
Audio Control		Switching preout	
Speaker Setting		Built-in Amp Mute Setting	
Display Mode Switching		Dual Zone System	
Upper text display part select		Dual Zone System Setting	
Lower text display part select		B.M.S. (Bass Management System)	
Level meter display part select		B.M.S. Frequency Offset	
Station/Disc Naming (SNPS/DNPS)		CRSC (Clean Reception System Circuit)	
Auxiliary Input Display Setting		Text Scroll	
Subwoofer Output		Built-in Auxiliary input Setting	
Faceplate Angle Adjustment		CD Read Setting	
Theft Deterrent Faceplate		AMP Control	
TEL Mute		Receive mode Setting	
<b>Tuner features</b>	<b>18</b>	<b>Basic Operations of remote</b>	<b>30</b>
Tuning Mode		<b>Accessories/ Installation Procedure</b>	<b>32</b>
Tuning		<b>Connecting Wires to Terminals</b>	<b>33</b>
Direct Access Tuning		<b>Installation</b>	<b>34</b>
Station Preset Memory		<b>Removing the Unit</b>	<b>36</b>
Auto Memory Entry		<b>Troubleshooting Guide</b>	<b>37</b>
Preset Tuning		<b>Specifications</b>	<b>40</b>
<b>CD/MP3/WMA/ External disc control features</b>	<b>20</b>		
Playing CD & MP3/WMA			
Playing External Disc			
Fast Forwarding and Reversing			
Track/File Search			
Disc Search/Folder Search			
Direct Track/File Search			
Direct Disc Search			
Track/File/Disc/Folder Repeat			
Scan Play			
Random Play			
Magazine Random Play			
Folder Select			
Text/Title Scroll			
DNPP (Disc Name Preset Play)			

## **▲ Warning**

---

### **▲ CAUTION**

Use of controls or adjustments or performance of procedures other than those specified herein may result in hazardous radiation exposure. In compliance with Federal Regulations, following are reproductions of labels on, or inside the product relating to laser product safety.

KENWOOD CORPORATION  
2967-3, ISHIKAWA-CHO,  
HACHIOJI-SHI  
TOKYO, JAPAN

KENWOOD CORP. CERTIFIES THIS EQUIPMENT  
CONFORMS TO DHHS REGULATIONS N0.21 CFR  
1040. 10, CHAPTER 1, SUBCHAPTER J.

Location : Bottom Panel

### **FCC WARNING**

This equipment may generate or use radio frequency energy. Changes or modifications to this equipment may cause harmful interference unless the modifications are expressly approved in the instruction manual. The user could lose the authority to operate this equipment if an unauthorized change or modification is made.

### **NOTE**

This equipment has been tested and found to comply with the limits for a Class B digital device, pursuant to Part 15 of the FCC Rules. These limits are designed to provide reasonable protection against harmful interference in a residential installation. This equipment may cause harmful interference to radio communications, if it is not installed and used in accordance with the instructions. However, there is no guarantee that interference will not occur in a particular installation. If this equipment does cause harmful interference to radio or television reception, which can be determined by turning the equipment off and on, the user is encouraged to try to correct the interference by one or more of the following measures:

- Reorient or relocate the receiving antenna.
- Increase the separation between the equipment and receiver.
- Connect the equipment into an outlet on a circuit different from that to which the receiver is connected.
- Consult the dealer or an experienced radio/TV technician for help.

## Safety precautions

---

### **▲WARNING**

#### **To prevent injury or fire, take the following precautions:**

- Insert the unit all the way in until it is fully locked in place. Otherwise it may fall out of place when jolted.
- When extending the ignition, battery, or ground wires, make sure to use automotive-grade wires or other wires with a  $0.75\text{mm}^2$  (AWG18) or more to prevent wire deterioration and damage to the wire coating.
- To prevent a short circuit, never put or leave any metallic objects (such as coins or metal tools) inside the unit.
- If the unit starts to emit smoke or strange smells, turn off the power immediately and consult your Kenwood dealer.
- Make sure not to get your fingers caught between the faceplate and the unit.
- Be careful not to drop the unit or subject it to strong shock.  
The unit may break or crack because it contains glass parts.

### **▲CAUTION**

#### **To prevent damage to the machine, take the following precautions:**

- Make sure to ground the unit to a negative 12V DC power supply.
- Do not open the top or bottom covers of the unit.
- Do not install the unit in a spot exposed to direct sunlight or excessive heat or humidity. Also avoid places with too much dust or the possibility of water splashing.
- Do not set the removed faceplate or the faceplate case in areas exposed to direct sunlight, excessive heat or humidity. Also avoid places with too much dust or the possibility of water splashing.
- To prevent deterioration, do not touch the terminals of the unit or faceplate with your fingers.
- Do not subject the faceplate to excessive shock, as it is a piece of precision equipment.
- When replacing a fuse, only use a new one with the prescribed rating. Using a fuse with the wrong rating may cause your unit to malfunction.
- To prevent a short circuit when replacing a fuse, first disconnect the wiring harness.
- Do not place any object between the faceplate and the unit.
- Do not apply excessive force to the moving faceplate. Doing so will cause damage or malfunction.
- Do not apply excessive force to the open faceplate or place objects on it. Doing so will cause damage or breakdown.
- Do not use your own screws. Use only the screws provided. If you use the wrong screws, you could damage the unit.

## About CD players/disc changers connected to this unit

KENWOOD disc changers/ CD players released in 1998 or later can be connected to this unit.

Refer to the catalog or consult your Kenwood dealer for connectable models of disc changers/ CD players.

Note that any KENWOOD disc changers/ CD players released in 1997 or earlier and disc changers made by other makers cannot be connected to this unit. Unsupported connection may result in damage. Setting the "O-N" Switch to the "N" position for the applicable KENWOOD disc changers/ CD players. The functions that can be used and the information that can be displayed will differ depending on the models being connected.



- You can damage both your unit and the CD changer if you connect them incorrectly.

## LX-bus connection

The LX AMP and the sensor unit cannot be connected simultaneously.

You must connect any of them at a time.

(The power supply does not turn ON if you have connected both of them.)

## Do Not Load 3-in. CDs in the CD slot

If you try to load a 3 in. CD with its adapter into the unit, the adapter might separate from the CD and damage the unit.

## NOTE

- If you experience problems during installation, consult your Kenwood dealer.
- If the unit fails to operate properly, press the Reset button. The unit returns to factory settings when the Reset button is pressed. If the unit still fails to operate properly after the Reset button has been pressed, contact your local KENWOOD dealer for assistance.
- Press the reset button if the disc auto changer fails to operate correctly. Normal operation should be restored.

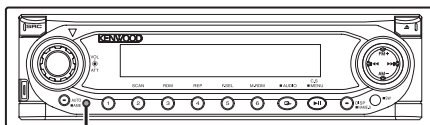

Reset button

- The illustrations of the display and the panel appearing in this manual are examples used to explain more clearly how the controls are used. Therefore, what appears on the display in the illustrations may differ from what appears on the display on the actual equipment, and some of the illustrations on the display may represent something impossible in actual operation.

## Lens Fogging

Right after you turn on the car heater in cold weather, dew or condensation may form on the lens in the CD player of the unit. Called lens fogging, CDs may be impossible to play. In such a situation, remove the disc and wait for the condensation to evaporate. If the unit still does not operate normally after a while, consult your Kenwood dealer.

## Notes

### Cleaning the Unit

If the faceplate of this unit is stained, wipe it with a dry soft cloth such as a silicon cloth.

If the faceplate is stained badly, wipe the stain off with a cloth moistened with neutral cleaner, then wipe neutral detergent off.



- Applying spray cleaner directly to the unit may affect its mechanical parts. Wiping the faceplate with a hard cloth or using a volatile liquid such as thinner or alcohol may scratch the surface or erase characters.

### Cleaning the Faceplate Terminals

If the terminals on the unit or faceplate get dirty, wipe them with a dry, soft cloth.

### Cleaning the CD Slot

As dust tends to accumulate in the CD slot, clean it every once in a while. Your CDs can get scratched if you put them in a dusty CD slot.

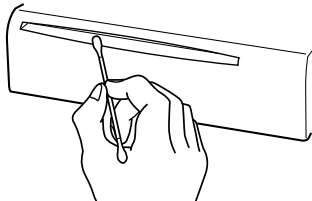

### NOTE

This Class B digital apparatus complies with Canadian ICES-003.

### About SIRIUS Satellite radio tuner

Refer to the instruction manual of SIRIUS Satellite radio tuner KTC-SR901/SR902 (optional accessory), when connected, for the operation method.

- KDC-X679/KDC-MP6025/KDC-MP625  
Refer to the sections of A models for operations.

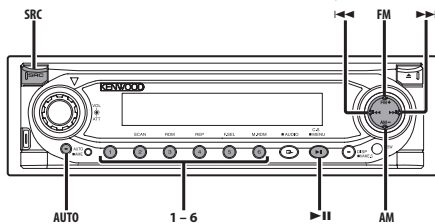

## About CDs

### Handling CDs

- Don't touch the recording surface of the CD.



- CD-R and CD-RW are easier to damage than a normal music CD. Use a CD-R or a CD-RW after reading the caution items on the package etc.
- Don't stick tape etc. on the CD. Also, don't use a CD with tape stuck on it.

### When using a new CD

If the CD center hole or outside rim has burrs, use it after removing them with a ball pen etc.

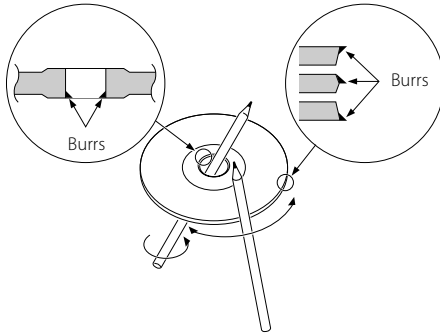

### CD accessories

Don't use disc type accessories.

### CD cleaning

Clean from the center of the disc and move outward.

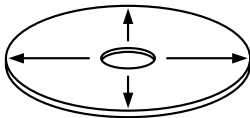

### Removing CDs

When removing CDs from this unit pull them out horizontally.

### CDs that can't be used

- CDs that aren't round can't be used.

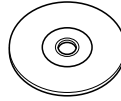

- CDs with coloring on the recording surface or that are dirty can't be used.
- This unit can only play the CDs with



It may not correctly play discs which do not have the mark.

- A CD-R or CD-RW that hasn't been finalized can't be played. (For the finalization process refer to your CD-R/CD-RW writing software, and your CD-R/CD-RW recorder instruction manual.)

### CD storage

- Don't place them in direct sunlight (On the seat or dashboard etc.) and where the temperature is high.
- Store CDs in their cases.

# Notes on playing MP3/WMA

KDC-X679/MP6025/MP625 can play MP3 (MPEG1, 2 Audio Layer 3)/WMA. Note, however, that the MP3/WMA recording media and formats acceptable are limited. When writing MP3/WMA, pay attention to the following restrictions.

## Acceptable media

The MP3/WMA recording media acceptable to this unit are CD-ROM, CD-R, and CD-RW.

When using CD-RW, do full format not quick format to prevent malfunction.

## Acceptable medium formats

The following formats are available for the media used in this unit. The maximum number of characters used for file and folder name including the delimiter (".") and three-character extension are indicated in parentheses.

- ISO 9660 Level 1 (12 characters)
- ISO 9660 Level 2 (31 characters)
- Joliet (64 character; Up to 32 characters are displayed)
- Romeo (128 character; Up to 64 characters are displayed)
- Long file name (200 characters; Up to 64 characters are displayed)
- Maximum number of characters for folder name: 64 (Joliet; Up to 32 characters are displayed)

For a list of available characters, see the instruction manual of the writing software and the section Entering file and folder names below.

The media reproducible on this unit has the following limitations:

- Maximum number of directory levels: 8
- Maximum number of files per folder: 255
- Maximum number of folders: 50

MP3/WMA written in the formats other than the above may not be successfully played and their file names or folder names are not properly displayed.

## Settings for your MP3/WMA encoder and CD writer

Do the following setting when compressing audio data in MP3/WMA data with the MP3/WMA encoder.

- Transfer bit rate: MP3: 8 —320 kbps  
WMA: 48 —192 kbps
- Sampling frequency  
MP3: 8, 11.025, 12, 16, 22.05, 24, 32, 44.1, 48 kHz  
WMA: 32, 44.1, 48 kHz

When you use your CD writer to record MP3/WMA up to the maximum disc capacity, disable additional writing. For recording on an empty disc up to the maximum capacity at once, check Disc at Once.



- Play mode may not be possible when portions of the functions of Windows Media Player 9 or higher are used.

## Entering ID3 tag

The Displayable ID3 tag is ID3 version 1.x.

For the character code, refer to the List of Codes.

0	1	2	3	4	5	6	7	8	9	A	B	C	D	E	F
0			0	@	P	3	D			■	°	À	Á	Â	ã
1			1	!	A	Q	a	q		ı	±	Ä	Å	ñ	ñ
2			"	2	B	R	b	r		e	²	Ä	Ö	ä	ö
3			#	3	C	S	c	s		ç	³	Å	Ö	ä	ö
4			\$	4	D	T	d	t		ç	´	Ä	Ö	ä	ö
5			%	5	E	U	e	u		¥	µ	Ä	Ö	ä	ö
6			&	6	F	V	f	v		ı	¶	Æ	O	æ	ö
7			'	7	G	W	g	w		\$	•	×	×	ç	±
8			(	8	H	X	h	x		¿	†	É	Ö	é	ö
9			)	9	I	Y	i	y		©	ı	Ê	Ü	ê	ü
A			*	:	J	Z	j	z		▲	▲	É	Ü	é	ü
B			+	:	K	[	k	[		«	»	Ê	Ü	é	ü
C			<	<	L	\	l	\		ı	ı	Û	ı	ı	ı
D			=	=	M	]	m	]		®	½	ı	ı	ı	ı
E			>	>	N	^	n	^		®	¾	ı	ı	ı	ı
F			/	/	?	O	_	o	■		—	ı	ı	ı	ı

## Entering file and folder names

The code list characters are the only file names and folder names that can be entered and displayed.

If you use any other character for entry, the file and folder names are not displayed correctly. They may neither be displayed correctly depending on the CD writer used.

The unit recognizes and plays only those MP3/WMA which have the MP3/WMA extension (.MP3/.WMA).



- A file with a name entered with characters not on the code list may not play correctly.

## Writing files into a medium

When a medium containing MP3/WMA data is loaded, the unit checks all the data on the medium. If the medium contains a lot of folders or non-MP3/WMA files, therefore, it takes a long time until the unit starts playing MP3/WMA.

In addition, it may take time for the unit to move to the next MP3/WMA file or a File Search or Folder Search may not be performed smoothly.



Loading such a medium may produce loud noise to damage the speakers.

- Do not attempt to play a medium containing a non-MP3/WMA file with the MP3/WMA extension.  
The unit mistakes non-MP3/WMA files for MP3/WMA data as long as they have the MP3/WMA extension.
- Do not attempt to play a medium containing non MP3/WMA.



## MP3/WMA playing order

When selected for play, Folder Search, File Search, or for Folder Select, files and folders are accessed in the order in which they were written by the CD writer.

Because of this, the order in which they are expected to be played may not match the order in which they are actually played. You may be able to set the order in which MP3/WMA are to be played by writing them onto a medium such as a CD-R with their file names beginning with play sequence numbers such as "01" to "99", depending on your CD writer.

For example, a medium with the following folder/file hierarchy is subject to Folder Search, File Search, or Folder Select as shown below.

### Example of a medium's folder/file hierarchy

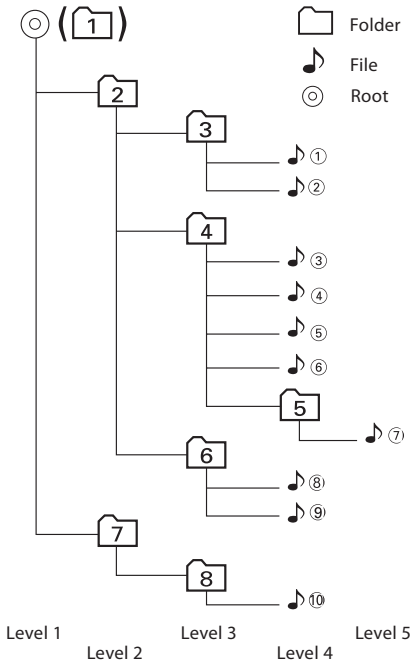

### When a File Search is executed with file 4 being played ...

Operation of the button	(Current file: 4)
⏮ Button	Beginning of file 4 → 3
⏭ Button	5 → 6

### When a Folder Search is executed with file 4 being played ...

Operation of the button	(Current folder: 4)
AM Button	3 → 2 → 1 → 8 ...
FM Button	5 → 6 → 7 → 8 → 1 ...

### When Folder Select is selected with file 4 being played to move from folder to folder ...

Operation of the button	(Current folder: 4)
⏮ Button	3
⏭ Button	6
AM Button	2
FM Button	5

# General features

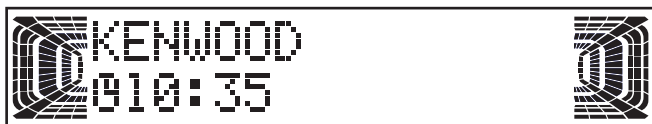
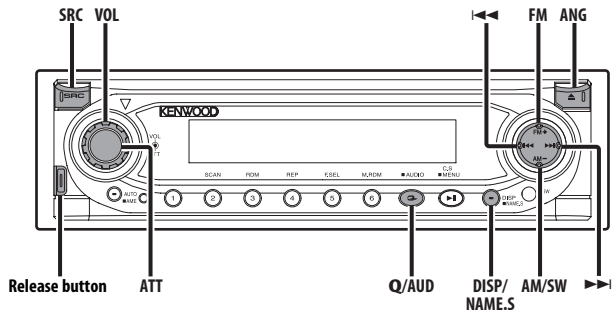

## Power

### Turning ON the Power

Press the [SRC] button.

### Turning OFF the Power

Press the [SRC] button for at least 1 second.

## Selecting the Source

Press the [SRC] button.

Source required	Display
SIRIUS tuner (Optional accessory)	"SIRIUS"
Tuner or HD Radio (Optional accessory)	"TUNER" or "HD RADIO"
CD	"CD"
External disc (Optional accessory)	"CD CH" / "MD CH"
Auxiliary input	
KDC-6025	"AUX"
KDC-X679/MP625 (Optional accessory)	"AUX EXT"
Standby (Illumination only mode)	"STANDBY"

## Volume

### Increasing Volume

Turn the [VOL] knob clockwise.

### Decreasing Volume

Turn the [VOL] knob counterclockwise.

## Attenuator

Turning the volume down quickly.

### Press the [ATT] button.

Each time the button is pressed the Attenuator turns ON or OFF.

When it's ON, "ATT ON" is displayed.

## System Q

You can recall the best sound setting preset for different types of music.

### 1 Select the source to set Press the [SRC] button.

### 2 Select the Sound type Press the [Q] button.

Each time the button is pressed the sound setting switches.

Sound setting	Display
Natural	"Natural"
User memory	"USER"
Rock	"ROCK"
Pops	"POPS"
Easy	"EASY"
Top 40	"TOP 40"
Jazz	"JAZZ"



- User memory: The values set on the 'Audio Control' (page 11).
- Each setting value is changed with the 'Speaker Setting' (page 12).  
First, select the speaker type with the Speaker setting.

## Audio Control

### 1 Select the source for adjustment Press the [SRC] button.

### 2 Enter Audio Control mode Press the [AUD] button for at least 1 second. "Audio Control" is displayed.

### 3 Select the Audio item for adjustment Press the [FM] or [AM] button.

Each time the button is pressed the items that can be adjusted switch as shown below.

### 4 Adjust the Audio item Press the [◀◀] or [▶▶] button.

Adjustment Item	Display	Range
Bass Center Frequency* <sup>2</sup>	"Bass FRQ"	60/70/80/100 or 150 Hz
Bass level	"Bass"	-8 — +8
Bass Q Factor* <sup>2</sup>	"Bass Q"	1.00/1.25/1.50/2.00
Bass Extend* <sup>2</sup>	"Bass EXT"	ON/OFF
Middle Center Frequency* <sup>2</sup>	"MID FRQ"	0.5/1.0/1.5/2.0 kHz

Middle level	"MID"	-8 — +8
Middle Q Factor* <sup>2</sup>	"Middle Q"	1.0/2.0
Treble Center Frequency* <sup>2</sup>	"TRE FRQ"	10.0/12.5/15.0/17.5 kHz
Treble level	"TRE"	-8 — +8
Balance	"Balance"	Left 15 — Right 15
Fader	"Fader"	Rear 15 — Front 15
Sub woofer level* <sup>1</sup>	"SW Level"	-15 — +15
Front High Pass Filter* <sup>2</sup>	"HPF Front"	Through/40/60/80/100/ 120/150/180/220 Hz
Rear High Pass Filter* <sup>2</sup>	"HPF Rear"	Through/40/60/80/100/ 120/150/180/220 Hz
Front/Rear High Pass Filter* <sup>3</sup>	"HPF"	Through/100/125/170 Hz
Sub woofer Low Pass Filter* <sup>1</sup>	"LPF SW"	50/80/120/Through Hz
Sub woofer phase* <sup>2</sup>	"SW Phase"	Normal (0°)/ Reverse (180°)
Volume offset	"Volume Offset"	-8 — ±0
Loudness	"Loudness"	ON/OFF



- According to the Bass Q Factor setting value, the frequencies that can be set in Bass Center Frequency change as shown below.

Bass Q Factor	Bass Center Frequency
1.00/1.25/1.50	60/70/80/100
2.00	60/70/80/150

- When the Bass Extend is set to ON, low frequency response is extended by 20%.
- Volume offset: Each source's volume can be set as a difference from the basic volume.
- Loudness: Compensating for low and high tones during low volume.
- \*<sup>1</sup> You can control this item when 'Switching preout' (page 27) is set to "SWPRE Sub-W". (KDC-MP6025/625 only)
- \*<sup>2</sup> Function of the KDC-X679
- \*<sup>3</sup> Function of the KDC-MP6025/MP625

### 5 Exit Audio Control mode Press the [AUD] button.

# General features

## Speaker Setting

Fine-tuning so that the System Q value is optimal when setting the speaker type.

### 1 Enter Standby

Press the [SRC] button.

Select the "STANDBY" display.

### 2 Enter Speaker Setting mode

Press the [Q] button.

"Speaker Setting" is displayed.

### 3 Select the Speaker type

Press the [◀◀] or [▶▶] button.

Each time the button is pressed the setting switches as shown below.

Speaker type	Display
OFF	"Speaker OFF"
For 5 & 4 in. speaker	"Speaker 5/4inch."
For 6 & 6x9 in. speaker	"Speaker 6*9/6inch"
For the OEM speaker	"Speaker O.E.M."

### 4 Exit Speaker Setting mode

Press the [Q] button.

## Display Mode Switching

Switching the display mode.

### 1 Enter display Control mode

Press the [DISP] button.

"Display Control" is displayed.

### 2 Select the Display mode

Press the [◀◀] button.

Each time the button is pressed the display switches as shown below.

Display Mode	Display
"Display type A"	
"Display type B"	
"Display type C"	

- ① Upper text display part
- ② Lower text display part
- ③ Level meter display part
- ④ Demonstration



- You can display the information that will be shown in the Upper text display part, the Lower text display part or the Level meter display part according to the setting of Display mode. Refer to the following pages for how to select the mode.

	DisplayA	DisplayB	DisplayC
Upper	page 12	page 12	—
Lower	page 14	page 14	—
Level	page 14	—	page 14

### 3 Exit Display Control mode

Press the [DISP] button.

## Upper text display part select

You can select the information displayed in the upper part in Display mode "Display Type A" or "Display Type B".

### 1 Enter display control mode

Press the [DISP] button.

"Display Control" is displayed.

### 2 Press the [FM] button.

Each time the button is pressed the display switches as shown below.

#### In Tuner source

Information	Display
Station name	"BAND+ch+SNPS"
Frequency	"BAND+ch+FREQ"

#### In CD & External disc source

Information	Display
Disc title	"Disc Title"
Track title	"Track Title"
Track number & Play time	"P-Time"
Disc name (In CD & CD Changer source)	"DNPS"

### **In MP3/WMA source**

<b>Information</b>	<b>Display</b>
Song title & Artist name	"Title/Artist"
Album name & Artist name	"Album/Artist"
Folder name	"Folder Name"
File name	"File Name"
Track number & Play time	"P-Time"

### **In SIRIUS tuner source**

<b>Information</b>	<b>Display</b>
Channel Name	"Channel Name"
Song Title	"Song Title"
Artist Name	"Artist Name"
Composer name	"Composer Name"
Category Name	"Category Name"
Label	"Label Name"
Comment	"Comment"
Band & Channel Number	"Channel Number"

### **In HD Radio source**

<b>Information</b>	<b>Display</b>
Station name	"Station Name"
Title	"Title"
Frequency	"Frequency"



- You cannot display the same information as the one in the Lower text display.
- During Standby, the upper part always displays "STANDBY".
- When you use Auxiliary input source, the upper part always displays "AUX Name".
- If the Disc title, Track title, Song title & Artist name, or Album name & Artist name is selected when the disc which does not have Disc title, Track title, Song title, Album name, or Artist name is played, track number and play time are displayed.

## **3 Exit Display control mode**

Press the [DISP] button.

# General features

## Lower text display part select

You can select the information displayed in the lower part in Display mode "Display Type A" or "Display Type B".

### 1 Enter display control mode

Press the [DISP] button.

"Display Control" is displayed.

### 2 Press the [AM] button.

Each time the button is pressed the display switches as shown below.

#### In Tuner source

Information	Display
Indicator	"Indicator"
Clock	"Clock"

#### In CD & External disc source

Information	Display
Indicator	"Indicator"
Clock	"Clock"
Disc title	"Disc Title"
Track title	"Track Title"
Disc name (In CD & CD Changer source)	"DNPS"

#### In MP3/WMA source

Information	Display
Indicator	"Indicator"
Clock	"Clock"
Song title & Artist name	"Title/Artist"
Album name & Artist name	"Album/Artist"
Folder name	"Folder Name"
File name	"File Name"

#### In STANDBY/Auxiliary input source

Information	Display
Indicator	"Indicator"
Clock	"Clock"

#### In SIRIUS tuner source

Information	Display
Indicator	"Indicator"
Clock	"Clock"
Channel Name	"Channel Name"
Song Title	"Song Title"
Artist Name	"Artist Name"
Composer name	"Composer Name"
Category name	"Category Name"

Label	"Label Name"
Comment	"Comment"

#### In HD Radio source

Information	Display
Indicator	"Indicator"
Clock	"Clock"
Station name	"Station Name"
Title	"Title"



- You cannot display the same information as the one in the Upper text display.
- When you select "Display Type B" for the Display mode, you can select only on and off of the clock display.
- If the Disc title, Track title, Song title & Artist name, or Album name & Artist name is selected when the disc which does not have Disc title, Track title, Song title, Album name, or Artist name is played, indicator are displayed.
- The indicator shown in this manual is displayed only when you chose the "Indicator" item of "Lower text display part select". No indicator is displayed if you select any item other than "Indicator".

### 3 Exit Display control mode

Press the [DISP] button.

## Level meter display part select

You can select the display of the Level meter in Display mode "Display Type A" and "Display Type C".

### 1 Enter display control mode

Press the [DISP] button.

"Display Control" is displayed.

### 2 Press the [▶▶] button.

Each time the button is pressed the display switches as shown below.

Level meter display part
Search Light
Symphony
Sniper
Silence
Level Meter A
Level Meter B

### 3 Exit Display control mode

Press the [DISP] button.



- When 'Dual Zone System' (page 27) is ON, Level meter cannot be switched.

## Station/Disc Naming (SNPS/DNPS)

Attaching a title to a Station or CD.

### 1 Receive/play the station/disc you want to attach a title to



- Refer to the 'Upper text display part select' (page 12) and select either "DNPS" or "SNPS". No name can be attached to the source if "DNPS" or "SNPS" cannot be selected for it.

### 2 Enter name set mode

Press the [NAME.S] button for at least 2 seconds.

"Name Set" is displayed.

### 3 Move the cursor to the enter character position

Press the [◀◀] or [▶▶] button.

### 4 Select the character type

Press the [▶II] button.

Each time the button is pressed the character type switches as shown below.

Character type	Display
Alphabet upper case	"A"
Alphabet lower case	"a"
Numbers and symbols	"*"
Special characters (Accent characters)	"á"

### 5 Select the characters

Press the [FM] or [AM] button.



- Characters can be entered by using a remote with a number buttons.

Example: If "DANCE" is entered.

Character	Button	Times pressed
"D"	[3]	1
"A"	[2]	1
"N"	[6]	2
"C"	[2]	3
"E"	[3]	2

### 6 Repeat steps 3 through 5 and enter the name.

### 7 Exit name set mode

Press the [NAME.S] button.



- When operation stops for 10 seconds the name at that time is registered, and Name Set mode closes.
- Memory numbers
  - Tuner: 30 stations
  - Internal CD player: 10 discs
  - External CD changer/ player: Varies according to the CD changer/ player. Refer to the CD changer/ player manual.
- The title of station/CD can be changed by the same operation used to name it.

## General features

### Auxiliary Input Display Setting

Selecting the display when this device is switched to Auxiliary input source.

#### 1 Select Auxiliary input source

Press the [SRC] button.

Select the "AUX"/ "AUX EXT" display.

#### 2 Enter Auxiliary input display setting mode

Press the [DISP] button for at least 2 seconds.

The presently selected AUX Name is blinks.

#### 3 Select the Auxiliary input display

Press the [◀◀] or [▶▶] button.

Each time the button is pressed it switches through the below displays.

- "AUX"/ "AUX EXT"
- "TV"
- "VIDEO"
- "GAME"
- "PORTABLE"
- "DVD"

#### 4 Exit Auxiliary input display setting mode

Press the [DISP] button.



- When operation stops for 10 seconds, the name at that time is selected, and Auxiliary input display setting mode closes.
- The Auxiliary Input Display can be set only when the built-in auxiliary input or the auxiliary input of optional KCA-S210A is used.

### Subwoofer Output

Turning the Subwoofer output ON or OFF.

Press the [SW] button for at least 1 second.

Each time the button is pressed Subwoofer output switches ON or OFF.

When it's ON, "Sub-W ON" is displayed.



- You can control this function when 'Switching preout' (page 27) is set to "SWPRE Sub-W".

### Faceplate Angle Adjustment

Press the [ANG] button for at least 1 second.



- Do not apply excessive force to the faceplate. It can cause damage.

### Theft Deterrent Faceplate

The faceplate of the unit can be detached and taken with you, helping to deter theft.

#### Removing the Faceplate

Press the Release button.

The faceplate is unlocked, allowing you to detach it.

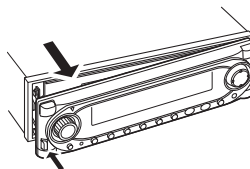

- The faceplate is a precision piece of equipment and can be damaged by shocks or jolts. For that reason, keep the faceplate in its special storage case while detached.
- Do not expose the faceplate or its storage case to direct sunlight or excessive heat or humidity. Also avoid places with too much dust or the possibility of water splashing.

#### Reattaching the Faceplate

1 Align the shaft on the unit with the depression on the faceplate.

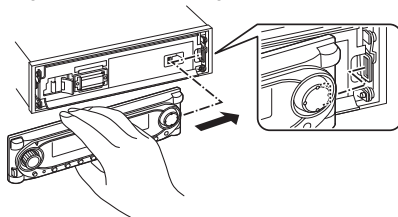



## 2 Push the faceplate in until it clicks.

The faceplate is locked in place, allowing you to use the unit.

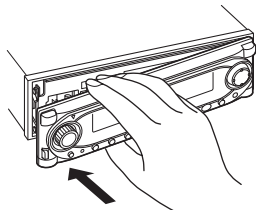

## TEL Mute

---

The audio system automatically mutes when a call comes in.

### ***When a call comes in***

"CALL" is displayed.

The audio system pauses.

### ***Listening to the audio during a call***

Press the [SRC] button.

The "CALL" display disappears and the audio system comes back ON.

### ***When the call ends***

Hang up the phone.

The "CALL" display disappears and the audio system comes back ON.

## Tuner features

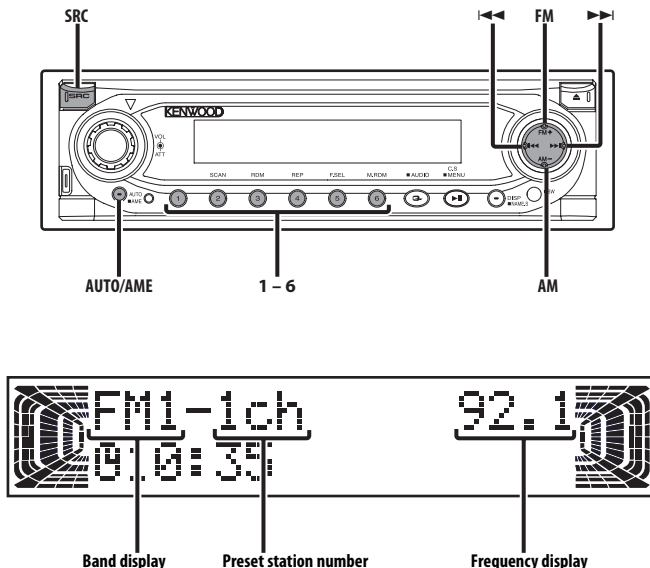

### Tuning Mode

Choose the tuning mode.

Press the [AUTO] button.

Each time the button is pressed the Tuning mode switches as shown below.

Tuning mode	Display	Operation
Auto seek	"Auto 1"	Automatic search for a station.
Preset station seek	"Auto 2"	Search in order of the stations in the Preset memory.
Manual	"Manual"	Normal manual tuning control.

### Tuning

Selecting the station.

#### 1 Select tuner source

Press the [SRC] button.

Select the "TUNER" display.

#### 2 Select the band

Press the [FM] or [AM] button.

Each time the [FM] button is pressed it switches

between the FM1, FM2, and FM3 bands.

#### 3 Tune up or down band

Press the [◀◀] or [▶▶] button.



- During reception of stereo stations the "ST" indicator is ON.

Function of remote

### Direct Access Tuning

Entering the frequency and tuning.

#### 1 Select the band

Press the [FM] or [AM] button.

#### 2 Enter Direct Access Tuning mode

Press the [DIRECT] button on the remote.

"- - - -" is displayed.

#### 3 Enter the frequency

Press the number buttons on the remote.

Example:

Desired frequency	Press button
92.1 MHz (FM)	[0], [9], [2], [1]
810 kHz (AM)	[0], [8], [1], [0]

### **Canceling Direct Access Tuning**

Press the [DIRECT] button on the remote.

## **Station Preset Memory**

Putting the station in the memory.

### **1 Select the band**

Press the [FM] or [AM] button.

### **2 Select the frequency to put in the memory**

Press the [◀◀] or [▶▶] button.

### **3 Put the frequency in the memory**

Press the desired [1] — [6] button for at least 2 seconds.

The preset number display blinks 1 time.

On each band, 1 station can be put in the memory on each [1] — [6] button.

## **Auto Memory Entry**

Putting stations with good reception in the memory automatically.

### **1 Select the band for Auto Memory Entry**

Press the [FM] or [AM] button.

### **2 Open Auto Memory Entry**

Press the [AME] button for at least 2 seconds.

When 6 stations that can be received are put in the memory Auto Memory Entry closes.

## **Preset Tuning**

Calling up the stations in the memory.

### **1 Select the band**

Press the [FM] or [AM] button.

### **2 Call up the station**

Press the desired [1] — [6] button.

# CD/MP3/WMA/External disc control features

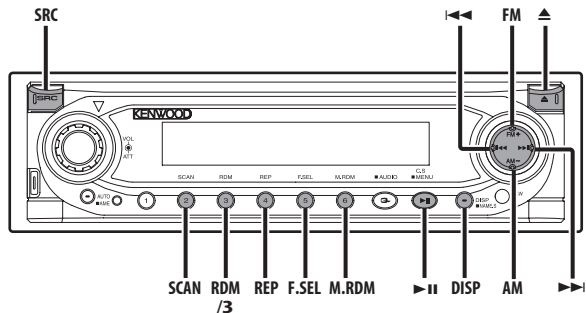

## Playing CD & MP3/WMA

### When there is no disc inserted

- 1 Open the panel to insert disc**  
Press the [▲] button.
- 2 Insert a disc.**



- When the faceplate has been slid open, it might interfere with the shift lever or something else. If this happens, pay attention to safety and move the shift lever or take an appropriate action, then operate the unit.



- When a disc is inserted the "IN" indicator is ON.

### When a disc is inserted

Press the [SRC] button.  
Select the "CD" display.

### Pause and play

Press the [▶||] button.  
Each time the button is pressed the song pauses or plays.

## Eject the disc

- 1 Eject the disc**  
Press the [▲] button.
- 2 Return the panel to the original position**  
Press the [▲] button.



- 3 in. (8cm) disc can't be played. Using an adapter and inserting them into this unit can cause damage.



- The MP3/WMA media that this unit can play are CD-ROM, CD-R, and CD-RW.  
The medium formats must be ISO 9660 Level 1, Level 2, Joliet, or Romeo. The methods and precautions to be followed for writing MP3/WMA data are covered in 'Notes on playing MP3/WMA' (page 8). Check that section before creating your MP3/WMA media.

## Playing External Disc

---

Playing discs set in the optional accessory disc player connected to this unit.

Press the [SRC] button.

Select the display for the disc player you want.

Display examples:

Display	Disc player
"CD 2"	CD player
"CD CH"	CD changer
"MD CH"	MD changer

### Pause and play

Press the [▶II] button.

Each time the button is pressed it pauses and plays.



- The functions that can be used and the information that can be displayed will differ depending on the external disc players being connected.

## Fast Forwarding and Reversing

---

### Fast Forwarding

Hold down on the [▶▶] button.

Release your finger to play the disc at that point.

### Reversing

Hold down on the [◀◀] button.

Release your finger to play the disc at that point.

## Track/File Search

---

Searching for a song on the disc or in the MP3/WMA folder.

Press the [◀◀] or [▶▶] button.

*Function of disc changer/ MP3/ WMA*

## Disc Search/Folder Search

---

Selecting the disc set in the Disc changer or the folder recorded on the MP3/WMA media.

Press the [FM] or [AM] button.

*Function of remote*

## Direct Track/File Search

---

Doing Track/File Search by entering the track/file number.

### 1 Enter the track/file number

Press the number buttons on the remote.

### 2 Do Track/File Search

Press the [◀◀] or [▶▶] button.

### Canceling Direct Track/File Search

Press the [▶II] button.

*Function of disc changers with remote*

## Direct Disc Search

---

Doing Disc Search by entering the disc number.

### 1 Enter the disc number

Press the number buttons on the remote.

### 2 Do Disc Search

Press the [DISC+] or [DISC-] button.

### Canceling Direct Disc Search

Press the [▶II] button.

# CD/MP3/WMA/External disc control features

## Track/File/Disc/Folder Repeat

Replaying the song, disc in the Disc changer or MP3/WMA folder you're listening to.

**Press the [REP] button.**

Each time the button is pressed the Repeat Play switches as shown below.

### In CD & External disc source

Repeat play	Display
Track Repeat	"(Track) Repeat ON"
Disc Repeat (In Disc Changer)	"Disc Repeat ON"
OFF	"Repeat OFF"

### In MP3/WMA source

Repeat play	Display
File Repeat	"File Repeat ON"
Folder Repeat	"Folder Repeat ON"
OFF	"Repeat OFF"

## Scan Play

Playing the first part of each song on the disc or MP3/WMA folder you are listening to and searching for the song you want to listen to.

### 1 Start Scan Play

**Press the [SCAN] button.**

"Scan ON"/ "Track Scan ON" is displayed.

### 2 Release it when the song you want to listen to is played

**Press the [SCAN] button.**

## Random Play

Playing all the songs on the disc in random order.

**Press the [RDM] button.**

Each time the button is pressed Random Play turns ON or OFF.

When it's ON, "Random ON" is displayed.



- When the [▶▶] button is pressed, the next song select starts.

### Function of disc changer

## Magazine Random Play

Play the songs on all the discs in the disc changer in random order.

**Press the [M.RDM] button.**

Each time the button is pressed the Magazine Random Play turns ON or OFF.

When it's ON, "Magazine RDM ON" is displayed.



- When the [▶▶] button is pressed, the next song select starts.

### Function of MP3/WMA

## Folder Select

Quickly selecting the folder you want to listen to.

### 1 Enter Folder Select mode

**Press the [F.SEL] button.**

"Select Mode" is displayed.

During Select mode the folder information is displayed as shown below.



Folder number display  
Displays the number in the folder belonging to the currently selected folder.

### 2 Select the folder level

**Press the [FM] or [AM] button.**

With the [FM] button you move 1 level down and with the [AM] button 1 level up.

### Selecting a folder in the same level

**Press the [◀◀] or [▶▶] button.**

With the [◀◀] button you move to the previous folder, and with the [▶▶] button to the next folder.

### Returning to the top level

**Press the [3] button.**

### 3 Decide the folder to play

**Press the [▶II] button.**

The Folder Select mode releases, and the MP3/WMA in the folder being displayed is played.



- The methods for moving to other folders in the folder select mode are different from those in the folder search mode.  
See 'Notes on playing MP3/WMA' (page 8) for details.

### **Canceling the Folder Select mode**

Press the [F.SEL] button.

---

## **Text/Title Scroll**

Scrolling the displayed CD text or MD title.

Press the [DISP] button for at least 1 second.

*Function of disc changers with remote*

---

## **DNPP (Disc Name Preset Play)**

Selecting the CD displayed in the DNPS of the CDs set in the Disc changer.

### **1 Enter DNPP mode**

Press the [DNPP] button on the remote.

When "DNPP" is displayed the DNPS display in order.

### **Forward / Reverse display**

Press the [DISC-] or [DISC+] button.

### **2 When the disc you want is displayed**

Press the [OK] button on the remote.

The disc being displayed is played.

### **Canceling the DNPP mode**

Press the [DNPP] button on the remote.

## HD Radio control features

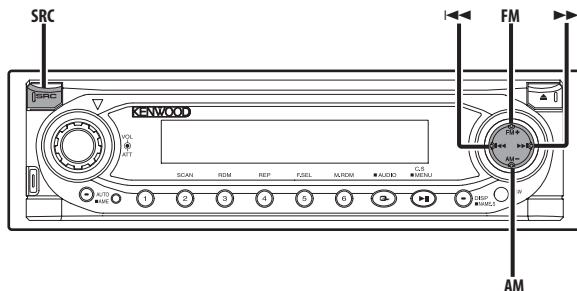

### Tuning

Selecting the station.

#### 1 Select HD Radio source

Press the [SRC] button.

Select the "HD RADIO" display.

#### 2 Select the HF band

Press the [FM] button.

Each time the [FM] button is pressed it switches between the HF1, HF2, and HF3 bands.

Select the HA band

Press the [AM] button.

#### 3 Tune up or down band

Press the [◀◀] or [▶▶] button.



- When you connect an HD Radio, Tuner features of the unit are disabled and switched to HD Radio tuner features. A portion of the setting methods including the Tuning Mode will change.
- With the HD Radio tuner, you can use the similar functions to 'Station Preset Memory', 'Auto Memory Entry', and 'Preset Tuning' of Tuner features. Refer to Tuner features for how to use the functions.

- The HD Radio cannot be selected as a dual zone source.



# Menu system

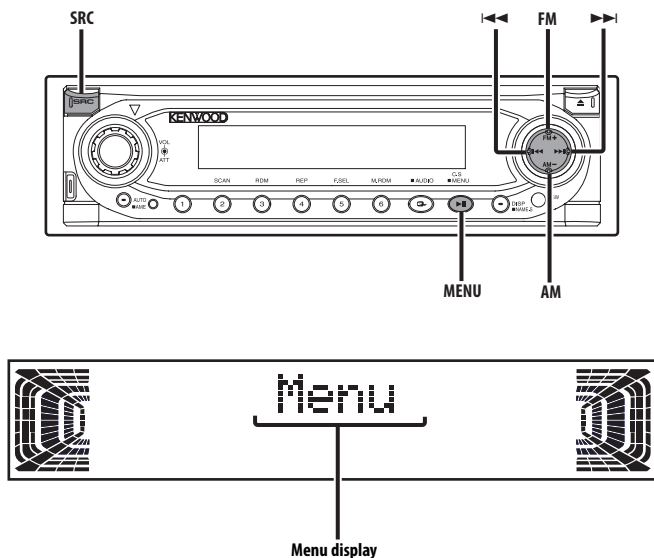

## Menu System

Setting during operation beep sound etc. functions.

The Menu system basic operation method is explained here. The reference for the Menu items and their setting content is after this operation explanation.

### 1 Enter Menu mode

Press the [MENU] button for at least 1 second.

"Menu" is displayed.

### 2 Select the menu item

Press the [FM] or [AM] button.

Example: When you want to set the beep sound select the "Beep" display.

### 3 Set the menu item

Press the [◀◀] or [▶▶] button.

Example: When "Beep" is selected, each time the button is pressed it switches "Beep ON" or "Beep OFF". Select 1 of them as the setting.

You can continue by returning to step 2 and setting other items.

### 4 Exit Menu mode

Press the [MENU] button.



- When other items that are applicable to the basic operation method above are displayed afterwards their setting content chart is entered. (Normally the uppermost setting in the chart is the original setting.) Also, the explanation for items that aren't applicable ('Manual Clock Adjustment' etc.) are entered step by step.

# Menu system

In Standby mode

## Security Code

Because authorization by the Security Code is required when it's removed from the vehicle, personalizing this unit is by using the Security Code is a help in preventing theft.



- When the Security Code function is activated, the code can't be changed and the function can't be released. Note, the Security Code can be set as the 4 digit number of your choice.

### 1 Enter Standby

Press the [SRC] button.

Select the "STANDBY" display.

### 2 Enter Menu mode

Press the [MENU] button for at least 1 second.

When "Menu" is displayed, "Security" is displayed.

### 3 Enter Security Code mode

Press the [◀◀] or [▶▶] button for at least 1 second.

When "Enter" is displayed, "CODE" is displayed.

### 4 Select the digits to enter

Press the [◀◀] or [▶▶] button.

### 5 Select the Security Code numbers

Press the [FM] or [AM] button.

### 6 Repeat steps 4 and 5, and complete the Security Code.

### 7 Confirm the Security Code

Press the [▶▶] button for at least 3 seconds.

When "Re-Enter" is displayed, "CODE" is displayed.

### 8 Do the step 4 through 7 operation, and reenter the Security Code.

"Approved" is displayed.

The Security Code function activates.



- When the wrong Code is entered in steps 4 through 6, repeat from step 4.

**Press the Reset button and when it's removed from the battery power source**

### 1 Turn the power ON.

### 2 Do the step 4 through 7 operation, and enter the Security Code.

"Approved" is displayed.

The unit can be used.

## Touch Sensor Tone

Setting the operation check sound (beep sound) ON/OFF.

Display	Setting
"Beep ON"	Beep is heard.
"Beep OFF"	Beep canceled.

## Manual Clock Adjustment

### 1 Select Clock Adjustment mode

Press the [FM] or [AM] button.

Select the "Clock ADJ" display.

### 2 Enter Clock Adjust mode

Press the [◀◀] or [▶▶] button for at least 1 second.

The clock display blinks.

### 3 Adjust the hours

Press the [FM] or [AM] button.

**Adjust the minutes**

Press the [◀◀] or [▶▶] button.

### 4 Exit Clock adjustment mode

Press the [MENU] button.

## DSI (Disabled System Indicator)

A red indicator will blink on the unit after the faceplate is removed, warning potential thieves.

Display	Setting
"DSI ON"	LED flashes.
"DSI OFF"	LED OFF.

## Selectable Illumination

Selecting the button illumination color as green or red.

Display	Setting
"Button Red"	The illumination color is red.
"Button Green"	The illumination color is green.

## Dimmer

Dimming this unit's display automatically when the vehicle light switch is turned ON.

Display	Setting
"Dimmer ON"	The display dims.
"Dimmer OFF"	The display doesn't dim.

*Function of the KDC-X679*

## System Q Setting

Setting whether the display indicates the System Q factors (Bass center frequency, Bass Q factor, Bass extend, Middle center frequency, Middle Q factor, and Treble center frequency) in Audio control.

Display	Setting
"System Q ON"	The System Q factors are displayed.
"System Q OFF"	The System Q factors aren't displayed.

*Function of the KDC-MP625/KDC-MP6025  
In Standby mode*

## Switching preout

Switching the preout between the rear and subwoofer. (In subwoofer it outputs without effect from the fader control.)

Display	Setting
"SWPRE Rear"	Rear preout.
"SWPRE Sub-W"	Subwoofer preout.

*In Standby mode*

## Built-in Amp Mute Setting

Toggles ON or OFF the mute control on the built-in amplifier.

Turning ON this control enhances the preout quality.

Display	Setting
"AMP Mute OFF"	The built-in amplifier activates.
"AMP Mute ON"	The built-in amplifier deactivates.

*Function of the KDC-X679/KDC-MP6025  
In SIRIUS Tuner, External disc, or Auxiliary input source*

## Dual Zone System

Makes the sound different for the front channel and rear channel.

Display	Setting
"Zone 2 OFF"	The front and rear are the same source sound.
"Zone 2 ON"	The front and rear are the different source sound.



- When the Dual Zone System is on, there is only sound effect including Audio control for internal source.
- When you set the Dual zone system to ON while the subwoofer preout is switched ON, the sound of the subwoofer preout isn't output.
- When the source is selected to VZ-7000P/N (optional accessory), the VZ-7000P/N's sound is not output if the Dual Zone System is turned ON.

*Function of the KDC-X679/KDC-MP6025  
When the Dual Zone System is OFF*

## Dual Zone System Setting

Setting the Front channel and Rear channel sound in the Dual Zone System.

Display	Setting
"Zone 2 Rear"	The front is this unit's internal source, and the rear is selected source sound.
"Zone 2 Front"	The rear is this unit's internal source, and the front is selected source sound.

# Menu system

Function of the KDC-X679

## B.M.S. (Bass Management System)

Adjust the bass boost level of the external amplifier using the main unit.

Display	Setting
"AMP Bass Flat"	Bass boost level is flat.
"AMP Bass +6"	Bass boost level is low (+6dB).
"AMP Bass +12"	Bass boost level is mid (+12dB).
"AMP Bass +18"	Bass boost level is high (+18dB).



- Refer to the catalog or instruction manual for power amplifiers that can be controlled from this unit.
- For amplifiers there are the model that can be set from Flat to +18 dB, and the model that can be set from Flat to +12 dB.

When an amplifier that can only be set to +12 is connected to the unit, "AMP Bass +18" won't work correctly even if it's selected.

Function of the KDC-X679

## B.M.S. Frequency Offset

Setting the central frequency boosted by B.M.S.

Display	Setting
"AMP FREQ Normal"	Boost with the normal central frequency.
"AMP FREQ Low"	Drop the normal central frequency 20%.

In FM reception

## CRSC (Clean Reception System Circuit)

Temporarily have reception switched from stereo to mono to reduce multi-path noise when listening to the FM station.

Display	Setting
"CRSC ON"	The CRSC is ON.
"CRSC OFF"	The CRSC is OFF.



- Strong electrical fields (such as from power lines) may cause unstable sound quality when CRSC is turned ON. In such a situation, turn it OFF.

## Text Scroll

Setting the displayed text scroll.

Display	Setting
"Scroll Auto"	Repeats scroll.
"Scroll Manual"	Scrolls when the display changes.



- The text scrolled is shown below.
  - CD text
  - Folder name/ File name/ Song title/ Artist name/ Album name
  - MD title
  - Text for the SIRIUS tuner source, HD Radio source, including Channel name, etc.

Function of the KDC-MP6025

## Built-in Auxiliary Input Setting

Set the Built-in Auxiliary Input function.

Display	Setting
"AUX OFF"	When selecting the source there's no Auxiliary Input.
"AUX ON"	When selecting the source there's Auxiliary Input.

In Standby mode

## CD Read Setting

When there is a problem on playing a CD with special format, this setting play the CD by force.

Display	Setting
"CD Read 1"	Play CD and MP3/WMA.
"CD Read 2"	Play CD by force.



- Setting "CD Read 2" cannot play MP3/WMA. Some music CDs may not be played back even in the "CD Read 2" mode.

Function of the KDC-X679  
When LX AMP unit connecting

## AMP Control

You can control the LX AMP connected to the unit.

### 1 Select AMP Control mode

Press the [FM] or [AM] button.

Select the "AMP Control" display.

### 2 Enter AMP Control mode

Press the [◀◀] or [▶▶] button for at least 1 second.

### 3 Select the AMP Control item for adjustment

Press the [FM] or [AM] button.



- For the details of the AMP Control item, see the Instruction manual attached to the LX AMP.

### 4 Adjust the AMP Control item

Press the [◀◀] or [▶▶] button.

### 5 Exit AMP Control mode

Press the [MENU] button.



- You cannot use the LX AMP operation during standby mode.

In HD Radio mode

## Receive mode Setting

Sets the receive mode.

### 1 Select the Receive mode

Press the [FM] or [AM] button.

Select the "Receive Mode" display.

### 2 Enter Receive mode

Press the [◀◀] or [▶▶] button for at least 1 second.

### 3 Set the Receive mode

Press the [FM] or [AM] button.

Each time the button is pressed the Receive mode switches as shown below.

Receive mode	Display	Operation
Auto mode	"Auto"	Analog broadcasts and digital broadcasts will be switched automatically. When both are being transmitted, the digital broadcast will have priority.
Digital	"Digital"	Digital broadcasts only.
Analog	"Analog"	Analog broadcasts only.

### 4 Exit Receive mode

Press the [MENU] button.



- Even if the "Auto" setting, an analog broadcast will be received during the reception of a ball game mode (non-delayed broadcast program).

## Basic Operations of remote

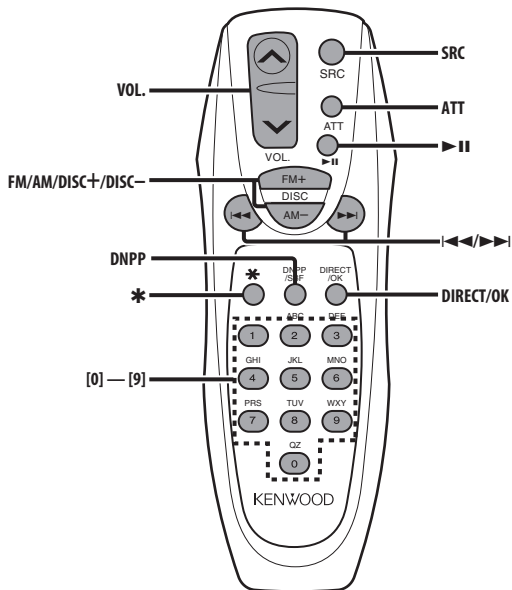

### Loading and Replacing the battery

Use two "AA"-size batteries.

Slide the cover while pressing downwards to remove it as illustrated.

Insert the batteries with the + and – poles aligned properly, following the illustration inside the case.

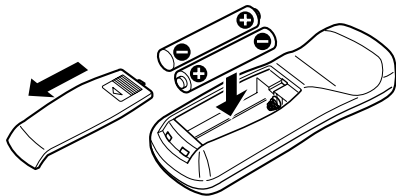

#### ⚠ WARNING

- Store unused batteries out of the reach of children. Contact a doctor immediately if the battery is accidentally swallowed.



- Do not set the remote on hot places such as above the dashboard.

### Basic operations

#### [VOL.] buttons

Adjusting the volume.

#### [SRC] button

Each time the button is pressed the source switches.

For the source switching order refer to 'Selecting the Source' (page 10).

#### [ATT] button

Turning the volume down quickly.

When it is pressed again it returns to the previous level.

#### [\*] button

Adjusting the Faceplate Angle.

## In Tuner source

---

### [FM]/ [AM] buttons

Select the band.

Each time the [FM] button is pressed it switches between the FM1, FM2, and FM3 bands.

### [◀◀]/ [▶▶] buttons

Tune up or down band.

### [0] — [9] buttons

Press buttons [1] — [6] to recall preset stations.

### [DIRECT]/ [OK] button

Enters and cancels the 'Direct Access Tuning' (page 18) mode.

## In Disc source

---

### [◀◀]/ [▶▶] buttons

Doing track/file forward and backward.

### [DISC+]/ [DISC-] buttons

Doing disc/folder forward and backward.

### [▶ II] button

Each time the button is pressed the song pauses and plays.

### [DNPP] button

Enters and cancels the 'DNPP (Disc Name Preset Play)' (page 23) mode.

### [0] — [9] buttons

When in 'Direct Track/File Search' (page 21) and 'Direct Disc Search' (page 21), enter the track/file/disc number.

## In SIRIUS tuner source

---

### [FM] buttons

Select the preset band.

### [◀◀]/ [▶▶] buttons

Search up or down channel.

### [0] — [9] buttons

Press buttons [1] — [6] to recall preset channels.

### [DIRECT]/ [OK] button

Enters and cancels the 'Direct Access Tuning' mode.

## In HD Radio source

---

### [FM] button

Select the HF band.

Each time the [FM] button is pressed it switches between the HF1, HF2, and HF3 bands.

### [AM] button

Select the HA band.

### [◀◀]/ [▶▶] buttons

Tune up or down band.

### [0] — [9] buttons

Press buttons [1] — [6] to recall preset stations.

# Accessories/ Installation Procedure

## Accessories

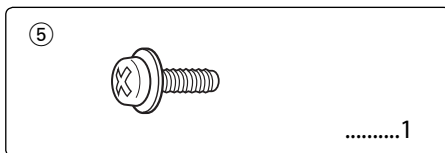
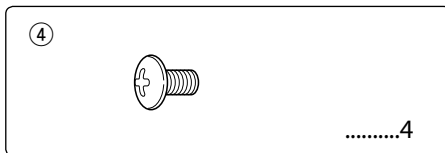
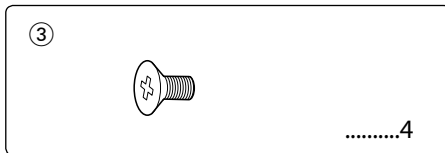
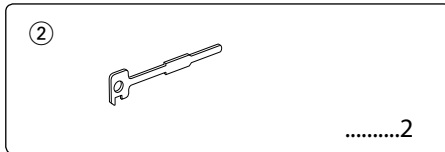
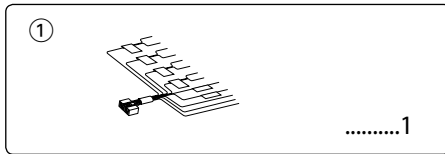

## Installation Procedure

1. To prevent a short circuit, remove the key from the ignition and disconnect the ⊖ battery.
2. Make the proper input and output wire connections for each unit.
3. Connect the speaker wires of the wiring harness.
4. Connect the wiring harness wires in the following order: ground, battery, ignition.
5. Connect the wiring harness connector to the unit.
6. Install the unit in your car.
7. Reconnect the ⊖ battery.
8. Press the reset button.

### ▲WARNING

If you connect the ignition wire (red) and the battery wire (yellow) to the car chassis (ground), you may cause a short circuit, that in turn may start a fire. Always connect those wires to the power source running through the fuse box.



- If your car's ignition does not have an ACC position, connect the ignition wires to a power source that can be turned on and off with the ignition key. If you connect the ignition wire to a power source with a constant voltage supply, as with battery wires, the battery may die.
- If the console has a lid, make sure to install the unit so that the faceplate will not hit the lid when closing and opening.
- If the fuse blows, first make sure the wires aren't touching to cause a short circuit, then replace the old fuse with one with the same rating.
- Insulate unconnected wires with vinyl tape or other similar material. To prevent a short circuit, do not remove the caps on the ends of the unconnected wires or the terminals.
- Connect the speaker wires correctly to the terminals to which they correspond. The unit may be damaged or fail to work if you share the ⊖ wires or ground them to any metal part in the car.
- When only two speakers are being connected to the system, connect the connectors either to both the front output terminals or to both the rear output terminals (do not mix front and rear). For example, if you connect the ⊕ connector of the left speaker to a front output terminal, do not connect the ⊖ connector to a rear output terminal.
- After the unit is installed, check whether the brake lamps, blinkers, wipers, etc. on the car are working properly.
- Mount the unit so that the mounting angle is 30° or less.



# Connecting Wires to Terminals

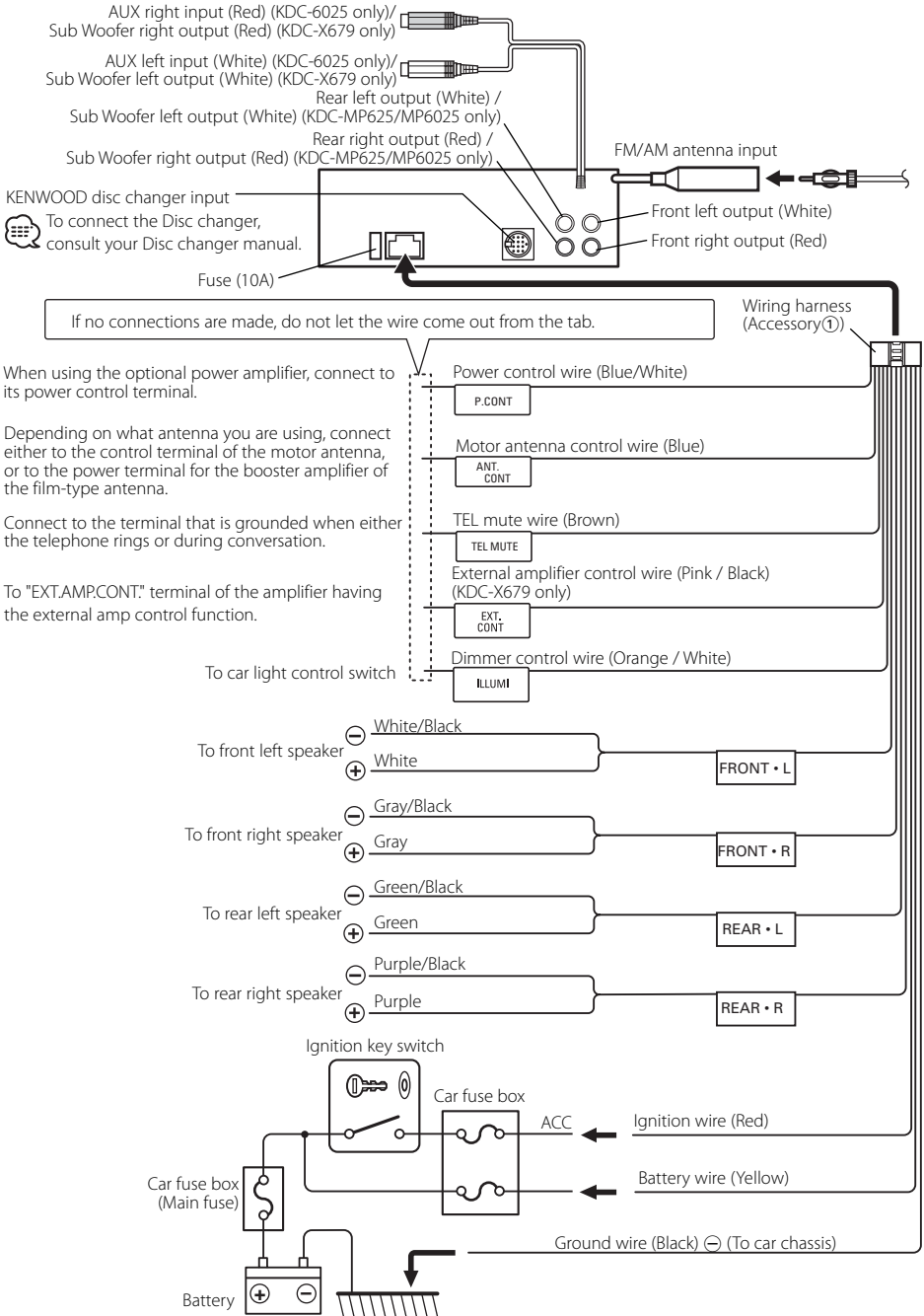

# Installation

## non-Japanese cars

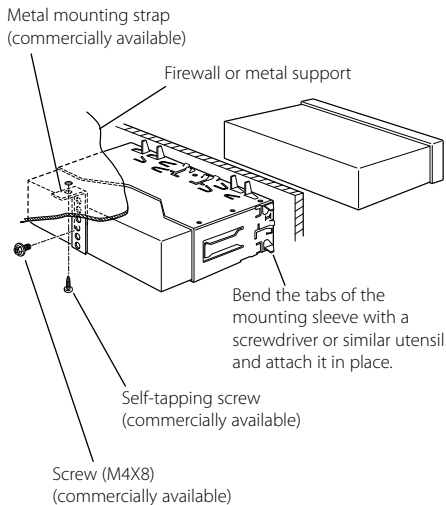

- Make sure that the unit is installed securely in place. If the unit is unstable, it may malfunction (for example, the sound may skip).

## Japanese cars

- 1 Refer to the section 'Removing the hard rubber frame' (page 36) and then remove the hard rubber frame.
- 2 Align the holes in the unit (two locations on each side) with the vehicle mounting bracket and secure the unit with the accessory screws.

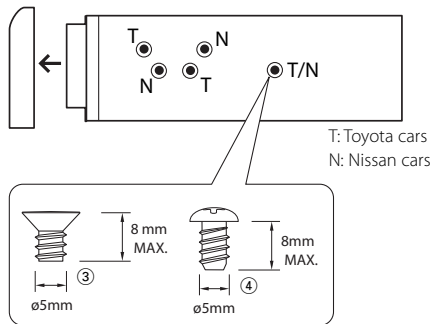

- During installation, do not use any screws except for those provided. The use of different screws might result in damage to the main unit.
- Damage may occur if a screwdriver or similar tool is used with excessive force during the installations.

## **Screwing the Faceplate on the Unit**

If you want to fasten the faceplate to the main unit so that it does not fall off, screw in the provided screws in the holes shown below.

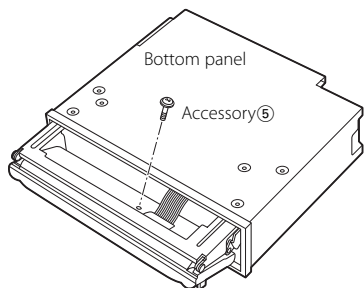

- Never insert the screw in any other screw hole than the one specified. If you screw them in another hole, it will contact and may cause damage to the mechanical parts inside the unit.

# Removing the Unit

## Removing the hard rubber frame

- 1 Engage the catch pins on the removal tool and remove the two locks on the upper level. Upper the frame and pull it forward as shown in the figure.

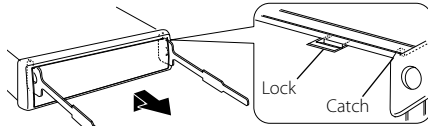

Accessory②  
Removal tool

- 2 When the upper level is removed, remove the lower two locations.

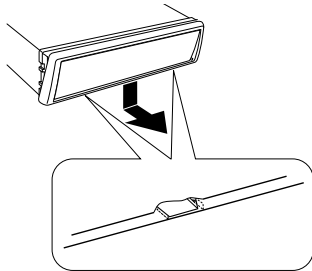

- The frame can be removed from the bottom side in the same manner.

## Removing the Unit

- 1 Refer to the section 'Removing the hard rubber frame' (page 36) and then remove the hard rubber frame.
- 2 Remove the screw (M4 × 8) on the back panel.
- 3 Insert the two removal tools deeply into the slots on each side, as shown.

Screw (M4X8)  
(commercially available)

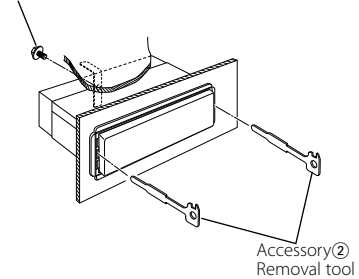

- 4 Lower the removal tool toward the bottom, and pull out the unit halfway while pressing towards the inside.

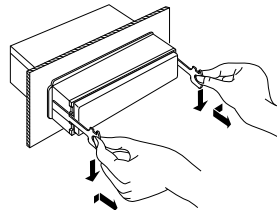

- Be careful to avoid injury from the catch pins on the removal tool.
- 5 Pull the unit all the way out with your hands, being careful not to drop it.

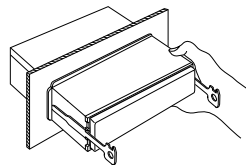

# Troubleshooting Guide

---

What might seem to be a malfunction in your unit may just be the result of slight misoperation or miswiring. Before calling service, first check the following table for possible problems.

## General

### ? The power does not turn ON.

- ✓ The fuse has blown.
    - ⓘ After checking for short circuits in the wires, replace the fuse with one with the same rating.
  - ✓ Speaker cable touches on chassis etc.
    - ⓘ Wire or insulate the speaker cable properly and press the reset button.
- 

### ? There's a source you can't switch.

- ✓ There's no media inserted.
    - ⓘ Set the media you want to listen to. If there's no media in this unit, you can't switch to each source.
  - ✓ The Disc changer isn't connected.
    - ⓘ Connect the Disc changer. If the Disc changer isn't connected to its input terminal, You can't switch to an external disc source.
- 

### ? The memory is erased when the ignition is turned OFF.

- ✓ The ignition and battery wire are incorrectly connected.
    - ⓘ Connect the wire correctly, referring to the section on 'Connecting Wires to Terminals'.
- 

### ? There's no loudness effect.

- ✓ You're using Subwoofer preout.
    - ⓘ Loudness has no effect in Subwoofer preout.
- 

### ? The TEL mute function does not work.

- ✓ The TEL mute wire is not connected properly.
    - ⓘ Connect the wire correctly, referring to the section on 'Connecting Wires to Terminals'.
- 

### ? The TEL mute function turns ON even though the TEL mute wire is not connected.

- ✓ The TEL mute wire is touching a metal part of the car.
    - ⓘ Pull the TEL mute wire away from the metal part of the car.
- 

### ? Even if Loudness is turned ON, high-pitched tone isn't compensated for.

- ✓ Tuner source is selected.
    - ⓘ High-pitched tone isn't compensated for when in Tuner source.
- 

### ? No sound can be heard, or the volume is low.

- ✓ The fader or balance settings are set all the way to one side.
    - ⓘ Center the fader and balance settings.
  - ✓ The input/output wires or wiring harness are connected incorrectly.
    - ⓘ Reconnect the input/output wires or the wiring harness correctly. See the section on 'Connecting Wires to Terminals'.
  - ✓ The values of Volume offset are low.
    - ⓘ Turn up the Volume offset, referring to the section on 'Audio Control' (page 11).
  - ✓ The 'Built-in Amp Mute Setting' (page 27) is ON.
    - ⓘ Turn it OFF.
- 

### ? The sound quality is poor or distorted.

- ✓ One of the speaker wires is being pinched by a screw in the car.
    - ⓘ Check the speaker wiring.
  - ✓ The speakers are not wired correctly.
    - ⓘ Reconnect the speaker wires so that each output terminal is connected to a different speaker.
- 

### ? The Touch Sensor Tone doesn't sound.

- ✓ The preout jack is being used.
    - ⓘ The Touch Sensor Tone can't be output from the preout jack.
- 

### ? The Dimmer function doesn't work.

- ✓ The Dimmer wire isn't connected correctly.
    - ⓘ Check the Dimmer wire connection.
- 

## Tuner source

### ? Radio reception is poor.

- ✓ The car antenna is not extended.
    - ⓘ Pull the antenna out all the way.
  - ✓ The antenna control wire is not connected.
    - ⓘ Connect the wire correctly, referring to the section on 'Connecting Wires to Terminals'.
- 

### ? The desired frequency can't be entered with the Direct Access Tuning.

- ✓ A station that can't be received is being entered.
    - ⓘ Enter a station that can be received.
  - ✓ You're trying to enter a frequency with a 0.01 MHz unit.
    - ⓘ What can be designated in the FM band is to 0.1 MHz.
-

# Troubleshooting Guide

## Disc source

### ? "AUX EXT" is displayed without achieving External disc control mode.

- ✓ Unsupported disc changer is connected.
  - ☞ Use the disc changer mentioned in the 'About CD players/disc changers connected to this unit' (page 5) of the section on 'Safety precautions'.

### ? The specified disc does not play, but another one plays instead.

- ✓ The specified CD is quite dirty.
  - ☞ Clean the CD.
- ✓ The disc is loaded in a different slot from that specified.
  - ☞ Eject the disc magazine and check the number for the specified disc.
- ✓ The disc is severely scratched.
  - ☞ Try another disc instead.

### ? A CD ejects as soon as it is loaded.

- ✓ The CD is quite dirty.
  - ☞ Clean the CD, referring to the CD cleaning of the section on 'About CDs' (page 7).

### ? Can't remove disc.

- ✓ The cause is that more than 10 minutes has elapsed since the vehicle ACC switch was turned OFF.
  - ☞ The disc can only be removed within 10 minutes of the ACC switch being turned OFF. If more than 10 minutes has elapsed, turn the ACC switch ON again and press the Eject button.

### ? The disc won't insert.

- ✓ There's already another disc inserted.
  - ☞ Press the [▲] button and remove the disc.

### ? Direct Search can't be done.

- ✓ Another function is ON.
  - ☞ Turn Random Play or other functions OFF.

### ? Track Search can't be done.

- ✓ For the discs/folders first or last song.
  - ☞ For each disc/folder, Track Search can't be done in the backward direction for the first song or in the forward direction for the last song.

## MP3/WMA source

### ? Cannot play an MP3/WMA.

- ✓ The media is scratched or dirty.
  - ☞ Clean the media, referring to the CD cleaning of the section on 'About CDs' (page 7).

### ? The sound skips when an MP3/WMA is being played.

- ✓ The media is scratched or dirty.
  - ☞ Clean the media, referring to the CD cleaning of the section on 'About CDs' (page 7).
- ✓ The recording condition is bad.
  - ☞ Record the media again or use another media.

### ? The MP3/WMA track time isn't displayed correctly.

- ✓ ---
  - ☞ There are times when it isn't displayed correctly according to the MP3/WMA recording conditions.

## HD Radio source

### ? No sound can be heard, or the volume is low.

- ✓ The preset broadcast station is not transmitting in the mode that was set with 'Receive mode Setting' (page 29).
  - ☞ Please set 'Receive mode Setting' to "Auto".
- ✓ In digital AM broadcasting, receive mode switches between stereo and monaural too often.
  - ☞ Receiving condition is bad or unstable. Stereo is chosen when receiving condition is good, and it switches to monaural when the condition becomes bad.
- ✓ HD Radio tuner is connected to KCA-S210A or other units.
  - ☞ Connect the HD Radio tuner directly to the control unit.

### If the following situations, consult your nearest service center:

Even though the disc changer is connected, the Disc Changer source is not ON, with "AUX EXT" showing in the display during the Changer Mode.

## The messages shown below display your systems condition.

Eject:	No disc magazine has been loaded in the changer. The disc magazine is not completely loaded. ↻ Load the disc magazine properly. No CD in the unit. ↻ Insert the CD.
No Disc:	No disc has been loaded in the disc magazine. ↻ Load a disc into the disc magazine.
TOC Error:	No disc has been loaded in the disc magazine. ↻ Load a disc into the disc magazine. The CD is quite dirty. The CD is upside-down. The CD is scratched a lot. ↻ Clean the CD and load it correctly.
Error 05:	The CD is upside-down. ↻ Load the CD correctly.
Blank Disc:	Nothing has been recorded on the MD.
No Track Disc:	No tracks are recorded on the MD, although it has a title.
Error 15:	Media was played that doesn't have data recorded that the unit can play. ↻ Use media that has data recorded that the unit can play.
No Music Data:	Media was played that doesn't have data recorded that the unit can play. ↻ Use media that has data recorded that the unit can play. Files for picture downloading only are recorded in CD-R/CD-RW.
No Panel:	The faceplate of the slave unit being connected to this unit has been removed. ↻ Replace it.
Error 77:	The unit is malfunctioning for some reason. ↻ Press the reset button on the unit. If the "Error 77" code does not disappear, consult your nearest service center.
Mecha Error:	Something is wrong with the disc magazine. Or the unit is malfunctioning for some reason. ↻ Check the disc magazine. And then press the reset button on the unit. If the "Mecha Error" code does not disappear, consult your nearest service center.
Error 99:	The unit is malfunctioning for some reason. ↻ Press the reset button on the unit. If the "Error 99" code does not disappear, consult your nearest service center.

Hold Error:	The protective circuit in the unit activates when the temperature inside the automatic disc changer exceeds 60°C (140°F), stopping all operation. ↻ Cool down the unit by opening the windows or turning on the air conditioner. As the temperature falls below 60°C (140°F), the disc will start playing again.
No Name:	Attempted to display the ID3 tag while the MP3/WMA having no ID3 tag is being played.
No Text:	Attempted to display text during reception of the station that isn't sending text data.
Load:	Discs are being exchanged in the Disc changer.
Reading:	The unit is reading the data on the disc.
No Access:	After setting it in the Disc Changer, DNPP was done without having it been played at least 1 time.
IN (Blink):	The CD player section is not operating properly. ↻ Reinsert the CD. If the CD cannot be ejected or the display continues to flash even when the CD has been properly reinserted, please switch off the power and consult your nearest service center.
Unsupported File:	A MP3/WMA is played with a format that this unit can't support. ↻ ----
Copy Protection:	A copy-protected file is played. ↻ ----

# Specifications

---

Specifications subject to change without notice.

## FM tuner section

---

Frequency range (200 kHz space)  
: 87.9 MHz – 107.9 MHz  
Usable sensitivity (S/N = 30dB)  
: 9.3dBf (0.8  $\mu$ V /75  $\Omega$ )  
Quieting Sensitivity (S/N = 50dB)  
: 15.2dBf (1.6  $\mu$ V /75  $\Omega$ )  
Frequency response ( $\pm$ 3.0 dB)  
: 30 Hz – 15 kHz  
Signal to Noise ratio (MONO)  
: 70 dB  
Selectivity ( $\pm$ 400 kHz)  
:  $\geq$  80 dB  
Stereo separation (1 kHz)  
: 40 dB

## AM tuner section

---

Frequency range (10 kHz space)  
: 530 kHz – 1700 kHz  
Usable sensitivity (S/N = 20dB)  
: 28 dB $\mu$  (25  $\mu$ V)

## CD player section

---

Laser diode  
: GaAlAs  
Digital filter (D/A)  
: 8 Times Over Sampling  
D/A Converter  
: 1 Bit  
Spindle speed  
: 1000 – 400 rpm (CLV 2times)  
Wow & Flutter  
: Below Measurable Limit  
Frequency response ( $\pm$ 1 dB)  
: 10 Hz – 20 kHz  
Total harmonic distortion (1 kHz)  
KDC-X679: 0.008 %  
KDC-MP6025/MP625: 0.01 %  
Signal to Noise ratio (1 kHz)  
KDC-X679: 106 dB  
KDC-MP6025/MP625: 105 dB  
Dynamic range  
: 93 dB  
Channel separation  
: 96 dB  
MP3 decode  
: Compliant with MPEG-1/2 Audio Layer-3  
WMA decode  
: Compliant with Windows Media Audio

## Audio section

---

Maximum output power  
: 50 W x 4  
Full Bandwidth Power (at less than 1% THD)  
: 22 W x 4  
Tone action  
Bass : 100 Hz  $\pm$ 10 dB  
Middle : 1 kHz  $\pm$ 10 dB  
Treble : 10 kHz  $\pm$ 10 dB  
Preout level / Load (during disc play)  
KDC-X679: 5000 mV/10 k $\Omega$   
KDC-MP6025/MP625: 2000 mV/10 k $\Omega$   
Preout impedance  
KDC-X679:  $\leq$ 80  $\Omega$   
KDC-MP6025/MP625:  $\leq$ 600 k $\Omega$

## Auxiliary input (KDC-MP6025)

---

Frequency response ( $\pm$ 1 dB)  
: 20 Hz – 20 kHz  
Input Maximum Voltage  
: 1200 mV  
Input Impedance  
: 100 k $\Omega$

## General

---

Operating voltage (11 – 16V allowable)  
: 14.4 V  
Current consumption  
: 10 A  
Installation Size (W x H x D)  
: 7-3/16 x 2-1/16 x 6-1/10 inch  
182 x 53 x 155 mm  
Weight  
: 3.1 lbs (1.4 kg)