

I N F O

INSTALLATION AND INSTRUCTION MANUAL

REFRIGERATOR

ER 6430 U

CONTENTS

Instructions for the User

Important Safety Instructions 3

Description of the Appliance 4

Operation 4

Before use 4

Setting the temperature 4

Fresh food refrigeration 4

The door shelves 5

Normal Operating Sounds 5

Health and Safety guidelines 6

Defrosting 6

Maintenance and Cleaning 7

Internal cleaning 7

Periodic cleaning 7

Changing the light bulb 7

When the appliance is not in use 7

Something Not Working? 8

Service and Spare Parts 9

Customer Care Department 9

Electrolux Service Force 10

Guarantee Conditions 12

Instructions for the Installer

Technical Specifications 13

Installation 13

Positioning 13

Electrical Connection 14

Building-in Instructions 15

Grid preparation 15

Door reversal 15

Building in the appliance under a worktop 16

Fitting the plinth 20

IMPORTANT SAFETY INSTRUCTIONS

These warnings are provided in the interests of your safety. Ensure that you understand them all before installing or using this appliance. Your safety is of paramount importance. If you are unsure about any of the meanings of these warnings contact the Customer Care Department.

Prior to Installation

- Check the appliance for transport damage. Under no circumstance should a damaged appliance be installed. In the event of damage please contact your retailer.

Installation

- This appliance is heavy. Care should be taken when moving it.
- It is dangerous to alter the specifications or attempt to modify this product in any way.
- Ensure that the appliance does not stand on the electrical supply cable.
Important: if the supply cable is damaged, it must be replaced by authorised service or qualified personnel using a special cable of the same type.
- Any electrical work required to install this appliance should be carried out by a qualified electrician or competent person.
- Parts which heat up should not be exposed. Whenever possible, the back of the appliance should be close to a wall, but leaving the required distance for ventilation, as stated in the installation instructions.
- The appliance should be left for 2 hours after installation before it is turned on, in order to allow the refrigerant to settle.

Refrigerant

- The refrigerant isobutane (R600a) is contained within the refrigerant circuit of the appliance, a natural gas with a high level of environmental compatibility, which is nevertheless flammable.
- During transportation and installation of the appliance, be certain that none of the components of the refrigerant circuit become damaged.
- If the refrigerant circuit should become damaged:
 - avoid open flames and sources of ignition.
 - thoroughly ventilate the room in which the appliance is situated.

Child Safety

- Do not allow children to tamper with the controls or play with the product.
- There is a risk of suffocation! Keep packaging material away from children!

General Safety

- **This appliance contains hydrocarbons in its cooling unit; maintenance and recharging must therefore only be carried out by authorised technicians.**
- **Take utmost care when handling your appliance so as not to cause any damages to the cooling unit with consequent possible fluid leakages.**
- **The appliance must not be located close to radiators or boilers.**
- **Avoid prolonged exposure of the appliance to direct sunlight.**
- **Do not use other electrical appliances (such as ice cream makers) inside of refrigerating appliances.**

During Use

- This appliance is designed for domestic use only, specifically for the storage of edible foodstuffs. It is not intended for commercial or industrial use.
- Containers with flammable gases or liquids can leak at low temperatures. Do not store any containers with flammable materials, such as spray cans, fire extinguisher refill cartridges etc. in the refrigerator.

Maintenance and Cleaning

- Before cleaning, always switch off the appliance and disconnect from the electrical supply.
- When unplugging always pull the plug from the mains socket, do not pull on the cable.

Servicing

- This product should be serviced by an authorised engineer and only genuine spare parts should be used.
- Under no circumstances should you attempt to repair the appliance yourself. Repairs carried out by inexperienced persons may cause injury or serious malfunctioning. Contact your local Service Force Centre.

At the end of the Appliance Life

- When disposing of your appliance use an authorised disposal site.
- Remove the plug and ensure that any locks or catches are removed, to prevent young children being trapped inside.

i DESCRIPTION OF THE APPLIANCE

- ① Dairy compartment
- ② Bottle storage shelf
- ③ Salad bins
- ④ Storage shelves
- ⑤ Thermostat control

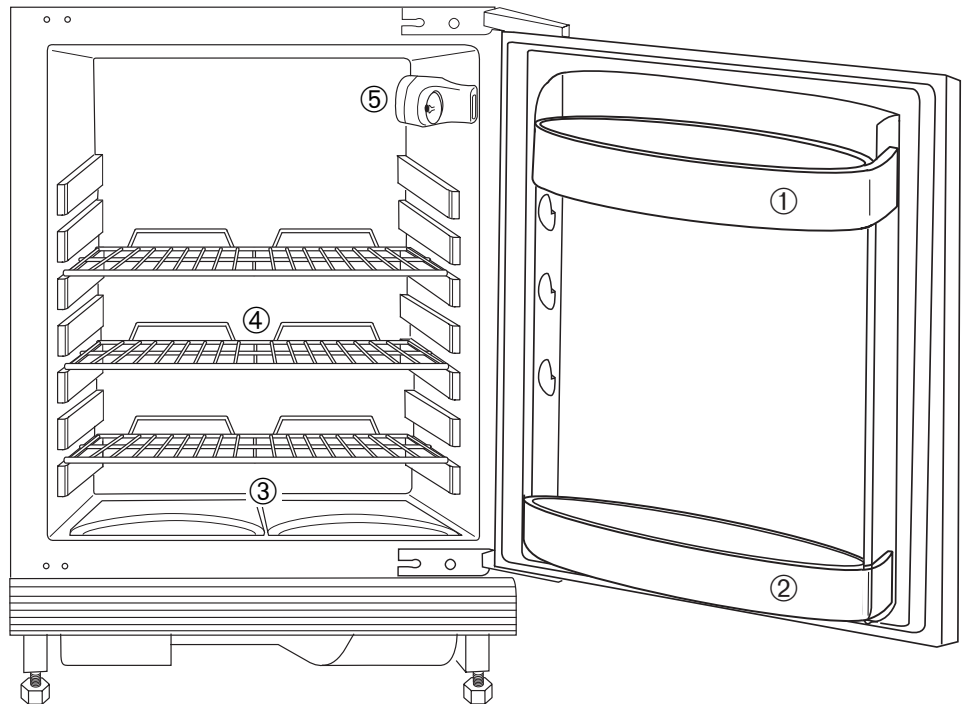

i OPERATION

Before use

Remove all securing tapes. Wash inside the appliance with lukewarm water and bicarbonate of soda (5 ml to 0.5 litre of water). Do not use soap or detergent as the smell may linger. Dry thoroughly.

Setting the temperature

The temperature inside the refrigerator is regulated by a thermostat with 6 temperature positions and one «OFF» (O) position.

Position 1 = minimum coldness

Position 6 = maximum coldness

Turn the thermostat dial to the required position.

An intermediate position is usually the most suitable, although the temperature will be affected by:

- Room temperature
- How often the door is opened
- How much food is stored
- Position of the appliance

In determining the correct temperature control setting all these factors have to be considered and some experimentation may be necessary.

When altering the temperature setting, allow 24 hours for the temperature to stabilise before making further changes.



Important

If the fridge is not defrosting correctly, it is possible that because a very low temperature has been selected, the motor is working continuously, which prevents the defrost cycle from operating.

During prolonged periods of abnormally hot weather, if the thermostat is set on too high a number, the cooling system may operate continuously and the fridge cooling plate may not defrost. Turning the knob to a lower number will cause the automatic defrosting to resume.

Fresh food refrigeration

To obtain the best performance, do not store warm food or evaporating liquids in the refrigerator; do cover or wrap the food, particularly if it has a strong flavour.

Do not cover the shelves with any protective material, such as paper, cardboard or plastic, which may obstruct the air circulation through them.

To help you use your refrigerator correctly, here are some more useful hints:

Raw meat (beef, pork, lamb & poultry): wrap in polythene bags and place on top of the salad drawers.

Meat can only be stored safely in this way for one or two days at the most.

Fruit & vegetables: these should be thoroughly cleaned and placed in the bottom salad drawers.

Butter & cheese: these should be placed in special airtight containers or wrapped in aluminium foil or polythene bags to exclude as much air as possible.

Milk bottles: these should have a cap and should be stored in the bottle rack on the door.

The walls of the refrigerator are equipped with runners so that shelves can be positioned as desired.

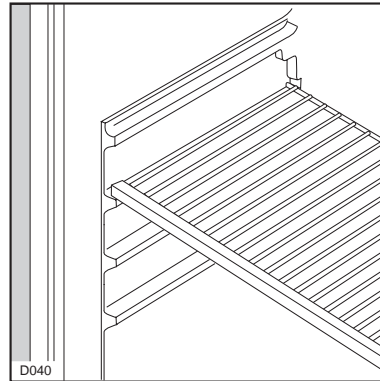

The door shelves

For more thorough cleaning, the butter shelf and the bottle shelf can be removed by pulling them in the direction of the arrows, then refitting them in position.

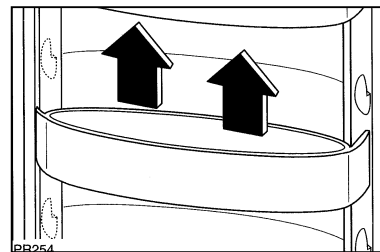

Normal Operating Sounds

You may hear faint gurgling or bubbling sounds when the refrigerant is pumped through the coils below, to the cooling evaporator.

When the compressor is on, the refrigerant is being pumped round, and you will hear a whirring sound or pulsating noise from the compressor. A thermostat controls the compressor, and you will hear a faint 'click' when the thermostat cuts in and out.

HEALTH AND SAFETY GUIDELINES

Because of consumer demand, preservatives have been removed from many pre-prepared foods. This together with the changes in shopping habits to a once-a-week shop, mean that safe handling and storage of food is even more important than ever.

The following tips should help you to ensure that the food in your home is in as perfect condition as possible.

- Keep the time between buying chilled food and placing it in your fridge as short as possible. Tests showed that the temperature of 1 litre of orange juice rose to 22°C in an hour between the super-market and home. It then took 11 hours to get down to 7°C in the refrigerator.
- Keep the refrigerator door closed as much as possible.
- Do not push food together too much, try to allow air to circulate around each item.
- Cool cooked food as quickly as possible but do NOT place in the refrigerator until cool. (Leave food in a cool place in order that it can then be placed in the refrigerator as soon as possible).
- Do NOT mix raw and cooked meat, they must be in separate containers. Take care not to let the meat juices drip onto other food. If the meat does drip, remove everything and clean thoroughly.
- Do not store food uncovered.
- Remove suspect food from your refrigerator and clean (Refer to "Maintenance and Cleaning").
- Never allow spillages to dry and harden.
- Store eggs in the egg rack provided in the refrigerator door. Discard any broken or chipped eggs.
- Regularly check the refrigerator door seal to ensure that it is clean and free from debris.
- Always wash your hands with soapy water and dry them with a clean towel before handling food.
- Keep work surfaces clean and avoid cross contamination by not using the same work surface or knife, without washing them thoroughly in between.

DEFROSTING

The refrigerator automatically defrosts every time the compressor stops. The water is discharged, via the pipe, into a tray located beneath the appliance adjacent to the compressor, where it evaporates.

 **Important**
To avoid defrost water overflowing and dripping onto the food in the fridge, periodically clean the water discharge hole (F) situated under the salad bins. Use the special cleaner provided (P) which you will find already inserted into the discharge hole

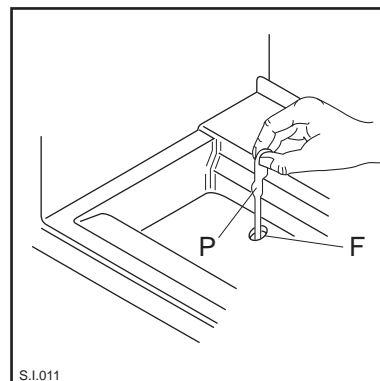

MAINTENANCE AND CLEANING

Before any maintenance or cleaning work is carried out, DISCONNECT the appliance from the ELECTRICITY supply.

 **Warning**
This appliance contains hydrocarbons in its cooling unit maintenance and recharging must therefore only be carried out by authorised technicians.

Internal cleaning

Clean the inside and accessories with warm water and bicarbonate of soda (5ml to 0.5 litre of water). Rinse and dry thoroughly.

NEVER USE DETERGENTS, ABRASIVE POWDERS, HIGHLY PERFUMED CLEANING PRODUCTS OR WAX POLISHES, TO CLEAN THE INTERIOR AS THESE WILL DAMAGE THE SURFACE AND LEAVE A STRONG SMELL.

Clean the drain hole of the water trough at regular intervals and make sure that the drain hole is never obstructed, so that the defrost water may flow freely.

 **Important**
Do not use abrasive products.

Periodic cleaning

The appliance is equipped with a ventilation grid. Keep clean to guarantee good ventilation and good working order of the appliance.

An accumulation of dust will affect the performance of the appliance and cause excessive electricity consumption.

The structure of the appliance permits cleaning of the rear zone close to the wall, using a vacuum cleaner.

1. Remove the plinth (1), then the ventilation grid (2);
2. Carefully pull the air deflector out (3), checking that there is no water left from the defrosting.

Changing the light bulb

Should the interior light fail to work, first switch off the appliance and disconnect from the electricity supply, then replace the bulb as follows:

1. Unscrew the light cover and then pull it outward by pressing as shown in the figure. Unscrew the bulb and replace it with a new 15 watt bulb (available from your nearest Electrolux Service Force centre).

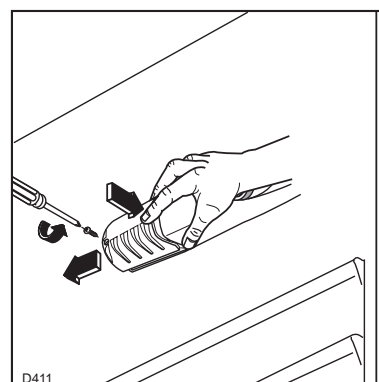

2. Replace the light cover by sliding it into its original position and replacing the screw.

When the appliance is not in use

When the appliance is not in use for long periods, disconnect from the electricity supply, empty all foods and clean the appliance, leaving the door ajar to prevent unpleasant smells.

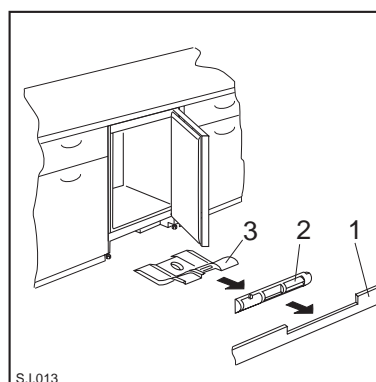

SOMETHING NOT WORKING?

Before contacting your local Service Force Centre check the following points.

IMPORTANT: If you call out an engineer to a fault listed below, or to repair a fault caused by incorrect use or installation, a charge will be made even if the appliance is under guarantee.

Symptom	Solution
No power to appliance	<ul style="list-style-type: none"> - Check there is power at the socket. - Check there is not a power cut by checking the household lights. - Check the fuse has not blown.
The light does not come on	<ul style="list-style-type: none"> - Ensure that the bulb is correctly fitted. - Replace the bulb if it has blown. - Check the door light switch is not jammed.
The temperature in the fridge or freezer section is too high	<ul style="list-style-type: none"> - Check the ambient temperature is within the appliances operating limits of 10°C to 38°C. - Check the thermostat is turned to the correct setting relative to ambient conditions.
The compressor runs continuously	<ul style="list-style-type: none"> - Adjust the thermostat control knob to give correct temperature control. See page 4. - Check that the door is closed. - Large quantities of food have recently been placed in the cabinet and/or door is frequently opened. - Check that air ventilation is not obstructed.
Excessive frost and ice has built up	<ul style="list-style-type: none"> - Ensure the door is not left open. - Check that nothing is preventing the door from closing. - Is the door gasket intact and clean.
Noise	<ul style="list-style-type: none"> - Refer to normal operating sounds.
Water under the salad bins	<ul style="list-style-type: none"> - Check the drain hole is not blocked. (see Maintenance and Cleaning).

If after the above checks, there is still a fault, call your local Service Force Centre.

In-guarantee customers should ensure that the above checks have been made as the engineer will make a charge if the fault is not a mechanical or electrical breakdown.

Please note that proof of purchase is required for any in-guarantee service calls.

SERVICE AND SPARE PARTS

In the event of your appliance requiring service, or if you wish to purchase spare parts please contact your local Electrolux Service Force Centre by telephoning:

0870 5 929929

Your telephone call will be automatically routed to the Service Centre covering your post code area. The addresses are listed on the following pages. Before calling out an engineer, please ensure you have read the details under the heading "Something Not Working" and have the model number and purchase date to hand.

Please note that it will be necessary to provide proof of purchase for any in-guarantee service calls. In-guarantee customers should ensure that the checks under the heading "Something Not Working" have been made as the engineer will make a charge if the fault is not a mechanical or electrical breakdown.

CUSTOMER CARE DEPARTMENT

For general enquiries concerning your Electrolux appliance or for further information on Electrolux products please contact our Customer Care Department by letter or telephone as follows:

Customer Care Department
Electrolux
55-77 High Street
Slough
Berkshire
SL1 1DZ

Tel: 08705 950 950 (*)

(*) calls to this number may be recorded for training purposes.

SERVICE FORCE

To contact your local Service Force Centre telephone 08705 929 929

CHANNEL ISLANDS		ISLE OF LEWIS ND Macleod 16 James Street Stornoway Isle of Lewis PA87 2QW	NORTH EAST	
GUERNSEY	Guernsey Electricity PO Box 4 Vale, Guernsey Channel Islands GY1 3AD	KELSO 2, 6 & 8 Woodmarket Kelso Borders TD5 7AX	GATESHEAD	Unit 356a Dukesway Court Dukesway Gateshead NE11 0BH
JERSEY	Jersey Electricity Company Haut De L'orme Rue De Haut De L'orme Trinity Jersey Channel Islands JE3 5FG	ORKNEY 7 King Street Kirkwall Orkney KW15 1JF	GRIMSBY	15 Hainton Avenue Grimsby N. E. Lincs DN32 9AS
SCOTLAND		PERTH Scottish Hydro Electric Central Warehouse Inveralmond Perth PH1 3AF	HULL	Unit 1 Boulevard Industrial Estate Hull HU3 4AY
ABERDEEN	54 Claremont Street Aberdeen AB10 6RA	(OWN SALES)	LEEDS	64-66 Cross Gates Road Cross Gates Leeds LS15 7YS
AUCHTERMUCHTY	33a Burnside Auchtermuchty Fife KY14 7AJ	SHETLAND 3-4 Carlton Place Lerwick Shetland ZE1 0PW	NEWTON AYCLIFFE	Unit 23 Northfield Way Aycliffe Industrial Park Newton Aycliffe DL5 6EJ
BLANTYRE	Unit 5 Block 2 Auchenraith Ind. Estate Rosendale Way Blantyre G72 0NJ	SHETLAND Bolts Shetland 26 North Road Lerwick Shetland ZE1 0PE	SHEFFIELD	Pennine House Roman Ridge Road Sheffield S9 1GB
DUMFRIES	93 Irish Street Dumfries DG1 2PQ	WHALSAY Leask Electrical Harisdale Symbister, Whalsay Shetland ZE2 9AA	NORTH WEST	
DUNOON	7 Hill Street Dunoon Argyll PA23 7AL	NORTHERN IRELAND		BIRKENHEAD
EDINBURGH	Unit 12 Dumbryden Ind. Estate 2 Dumbryden Road Edinburgh EH14 2AB	BELFAST	Owenmore House Kilwee Business Park Dunmurry Belfast BT17 0HD	1 Kelvin Park Dock Road Birkenhead CH41 1LT
GLASGOW	Unit 4 Wellington Road Bishopriggs Glasgow G64 2SA	WALES		CARLISLE
INVERNESS	Unit 3BI Smithton Ind. Estate Smithton Inverness IV2 7WL	CARDIFF	Unit 4 Guardian Industrial Estate Clydesmuir Road Cardiff CF2 2QS	Unit 7 James Street Workshops James Street Carlisle Cumbria CA2 5AH
ISLE OF ARRAN	Arran Domestics The Douglas Centre Brodick Isle of Arran KA27 8AJ	CLYWD	Unit 6-7 Coed Parc Abergele Road Rhuddlan Clwyd LL18 5UG	ISLE OF MAN
ISLE OF BARRA	J Zerfah 244 Bruernish Isle of Barra Western Islands HS9 5QY	DYFED	Unit 9 St. Clears Business Park Tenby Road St. Clears Carmarthen SA33 4JW	South Quay Ind. Estate Douglas Isle of Man IM1 5AT
ISLES OF BUTE	Walker Engineering Glenmhor Upper Serpentine Road Rothesay Isle of Bute PA20 9EH	OSWESTRY	Plas Ffynnon Warehouse Middleton Road Oswestry SY11 2PP	BOLTON
			NORTH WEST	
			BOLTON	Unit B Central Industrial Estate St Marks Street Bolton BL3 6NR
			PRESTON	Unit 250 Dawson Place Bamber Bridge Preston Lancashire PR5 8AL
			STOCKPORT	Unit 20 Haigh Park Haigh Avenue Stockport SK4 1QR

SERVICE FORCE

To contact your local Service Force Centre telephone 08705 929 929

MIDLANDS		LONDON & EAST ANGLIA		SOUTH EAST	
BIRMINGHAM	66 Birch Road East Wyrley Trading Estate Witton Birmingham B6 7DB	BECKENHAM	11a Gardner Ind. Estate Kent House Lane Beckenham Kent BR3 1QZ	ASHFORD	Unit 2 Bridge Road Business Centre Bridge Road Ashford Kent TN23 1BB
BOURNE	Pinfold Road Bourne PE10 9HT	CHELMSFORD	Hanbury Road Widford Ind. Estate Chelmsford Essex CM12 3AE	FLEET	Unit 1 Redfields Ind. Estate Church Crookham Fleet Hampshire GU13 0RD
BRIDGNORTH	68 St. Mary's Street Bridgnorth Shropshire WV16 4DR	COLINDALE	Unit 14 Capitol Park Capitol Way Colindale London NW9 0EQ	HAYWARDS HEATH	21-25 Bridge Road Haywards Heath Sussex RH16 1UA
GLOUCESTER	101 Rycroft Street Gloucester GL1 4NB	ELTHAM	194 Court Road Mottingham Eltham London SE9 4EW	TONBRIDGE	Unit 30 Deacon Trading Estate Morley Road Tonbridge TN9 1RA
HEREFORD	Units 3 & 4 Bank Buildings Cattle market Hereford HE4 9HX	ENFIELD	284 Alma Road Enfield London EN3 7BB	SOUTH WEST	
HIGHAM FERRERS	30 High Street Higham Ferrers Northants NN10 8PL	GRAVESEND	Unit B4 Imperial Business Estate West Mill Gravesend Kent DA11 0DL	BARNSTAPLE	Main Road Fremington Barnstaple North Devon EX31 2NT
ILKESTON	Unit 2 Furnace Road Ilkeston DE7 5EP	IPSWICH	Unit 6C Elton Park Business Centre Hadleigh Road Ipswich IP2 0DD	BOURNEMOUTH	63-65 Curzon Road Bournemouth Dorset BH1 4PW
LEICESTER	Unit 7 Oaks Industrial Estate Coventry Road Narborough Leicestershire LE9 5GF	LETCHWORTH	16-17 Woodside Ind. Park Works Road Letchworth Herts SG6 1LA	BRIDGEWATER	6 Herswell Business Park Salmon Parade Bridgwater Somerset TA6 5PY
LINCOLN	Unit 8 Clifton Street Stone Field Park Lincoln LN5 8LQ	LONDON	2 - 4 Royal Lane Yiewsley West Drayton Middlesex UB7 8DL	BRISTOL	11 Eldon Way Eldonwall Trading Estate Bristol BS4 3QQ
NEWCASTLE UNDER LYME	18-21 Croft Road Brampton Ind. Estate Newcastle under Lyme Staffordshire ST5 0TW	MAIDENHEAD	Reform Road Maidenhead Berkshire SL6 8BY	EMSWORTH	266 Main Road Southbourne Emsworth PO10 8JL
REDDITCH	13 Thornhill Road North Moons Moat Redditch Worcestershire B98 9ND	MOLESEY	10 Island Farm Avenue West Molesey Surrey KT8 2UZ	ISLE OF WIGHT	Unit 8 Enterprise Court Ryde Business Park Ryde Isle of Wight PO33 1DB
TAMWORTH	Unit 3 Sterling Park Claymore Tamworth B77 5DQ	NEWBURY	9 Pipers Court Berkshire Drive Thatcham Berkshire RG19 4ER	NEWTON ABBOT	Unit 2 Zealley Ind. Estate Kingsteignton Newton Abbot TQ12 3TD
WORCESTER	Units 1 & 2 Northbrooks Close Gregorys Mill Ind. Estate Worcester WR3 8BP	NORWICH	2b Trafalgar Street Norwich NR1 3HN	REDRUTH	Unit 7D Pool Ind. Estate Druids Road Redruth Cornwall TR15 3RH
		SUNBURY	Unit 1a The Summit Hanworth Road Sunbury on Thames TW16 5DB		

GUARANTEE CONDITIONS

Standard guarantee conditions

We, Electrolux, undertake that if within 12 months of the date of purchase this Electrolux appliance or any part thereof is proved to be defective by reason only of faulty workmanship or materials, we will, at our option repair or replace the same FREE OF CHARGE for labour, materials or carriage on condition that:

- The appliance has been correctly installed and used only on the electricity supply stated on the rating plate.
- The appliance has been used for normal domestic purposes only, and in accordance with the manufacturer's instructions.
- The appliance has not been serviced, maintained repaired, taken apart or tampered with by any person not authorised by us.
- All service work under this guarantee must be undertaken by an Electrolux Service Force Centre.
- Any appliance or defective part replaced shall become the Company's property.
- This guarantee is in addition to your statutory and other legal rights.

Home visits are made between **8.30am** and **5.30pm** Monday to Friday. Visits may be available outside these hours in which case a **premium** will be charged.

Exclusions

This guarantee does not cover:

- Damage or calls resulting from transportation, improper use or neglect, the replacement of any light bulbs or removable parts of glass or plastic.
- Costs incurred for calls to put right an appliance which is improperly installed or calls to appliances outside the United Kingdom.
- Appliances found to be in use within a commercial environment, plus those which are subject to rental agreements.
- Products of Electrolux manufacture which are not marketed by Electrolux.

European Guarantee

If you should move to another country within Europe then your guarantee moves with you to your new home subject to the following qualifications:

- The guarantee starts from the date you first purchased your product.
- The guarantee is for the same period and to the same extent for labour and parts as exists in the new country of use for this brand or range of products.
- This guarantee relates to you and cannot be transferred to another user.
- Your new home is within European Community (EC) or European Free Trade Area.
- The product is installed and used in accordance with our instructions and is only used domestically, i.e. a normal household.
- The product is installed taking into account regulations in your new country.

Before you move please contact your nearest Customer Care centre, listed below, to give them details of your new home. They will then ensure that the local Service Organisation is aware of your move and able to look after you and your appliance.

France	Senlis	+33 (0) 44 62 22 22
Germany	Nuremberg	+49 (0) 911 323 2600
Italy	Pordenone	+39 (0) 1678 47053
Sweden	Stockholm	+46 (0) 20 78 77 50
UK	Slough	+44 (0) 1753 219898

TECHNICAL SPECIFICATIONS

DIMENSIONS	Height	81,5	cm
	Width	59,6	cm
	Depth	54	cm

POWER SUPPLY VOLTAGE AND FREQUENCY	220-240 V / 50 Hz
TOTAL POWER ABSORBED	70 W
AVERAGE DAILY UNITS ELECTRICITY (*)	0,47 kWh

GROSS CAPACITY	142 l
----------------	-------

NET CAPACITY	140 l
--------------	-------

(*)This figure is based on standard test results in accordance with European Standard EN153. Actual consumption will depend on how the appliance is used and where it is located.

INSTALLATION

Positioning

This appliance should only be installed at a location where the ambient temperature corresponds to the climate classification indicated on the rating plate, which is located on the inside left of the appliance.

The following table shows which ambient temperature is correct for each climate classification.

SN +10°C to +32°C

ST +18°C to +38°C

The appliance should be located in a dry atmosphere, out of direct sunlight and away from continuous heat and extreme temperature, e.g. not next to a boiler or radiator, or in a very cold room e.g. an outhouse. If these temperatures are exceeded i.e. warmer or colder, then the appliance may not operate correctly.

For building-in and door reversal instructions please refer to the relevant instructions on the following pages.

ELECTRICAL CONNECTION



WARNING:

THIS APPLIANCE MUST BE EARTHED.
The manufacturer declines any liability should this safety measure not be observed.

If the plug that is fitted to your appliance is not suitable for your socket outlet, it must be cut off and the appropriate plug fitted.

Remove the fuse from the cut off plug.

The cut off plug should then be disposed of to prevent the hazard of shocks in case it should be plugged into a 13amp socket in another part of your home.



Important

The wires in the mains lead are coloured in accordance with the following code:

Green and Yellow	- Earth
Blue	- Neutral
Brown	- Live

If you fit your own plug, the colours of the wires in the mains lead of your appliance, may not correspond with the markings identifying the terminals in your plug, proceed as follows:

Connect the Green and the Yellow (earth) wire to the terminal in the plug which is marked with the letter «E» or the earth symbol \oplus , or coloured green and yellow.

Connect the blue (neutral) wire to the terminal in the plug which is marked with the letter «N» or coloured black.

Connect the brown (live) wire to the terminal in the plug which is marked with the letter «L» or coloured red.

The plug moulded onto the lead incorporates a fuse. For replacement, use a 13amp BS1362 fuse. Only ASTA or BSI approved fuses should be used.

The plug must not be used if the fuse cover/carrier is lost. The cover/carrier is indicated by the coloured insert at the base of the plug.

A replacement cover/carrier must be obtained from your local Electrolux Service Force Centre.

This appliance complies with the E.E.C. Directive No. 87/308 of 2.6.87 relative to radio interference suppression.



This appliance complies with the following E.E.C. Directive:

- 73/23 EEC of 19.2.73 (Low Voltage Directive) and subsequent amendments.
- 89/336 EEC of 3.5.89 (Electromagnetic Compatibility Directive) and subsequent amendments.

Please ensure that when the appliance is installed it is easily accessible for the engineer in the event of breakdown.

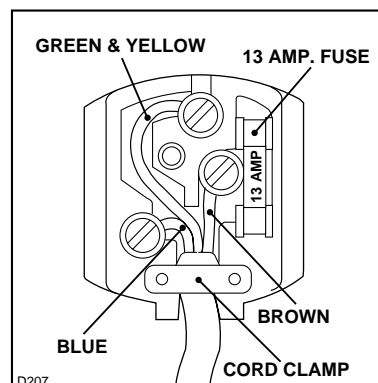

i BUILDING-IN INSTRUCTIONS

Before carrying out any work, remove the plug from the power socket.

Grid preparation

Left door opening:

Remove the left side (A) of the grid cutting it from the rear (see figure).

Right door opening:

Remove the right side (B) of the grid cutting it from the rear (see figure).

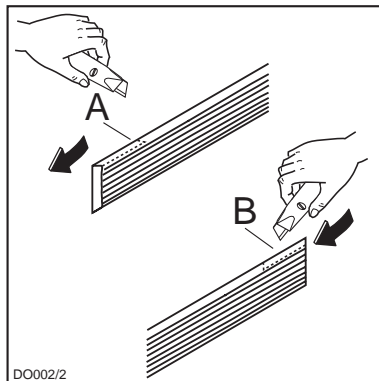

To position the grid on the appliance proceed as follows:

Apply the grid to the base of the appliance by pushing on to the clasps (a) until they click.

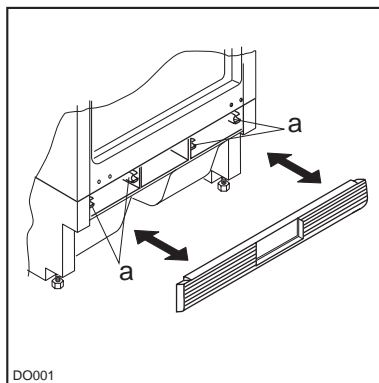

Door reversal

To reverse the opening direction of the door, proceed as shown in the figures:

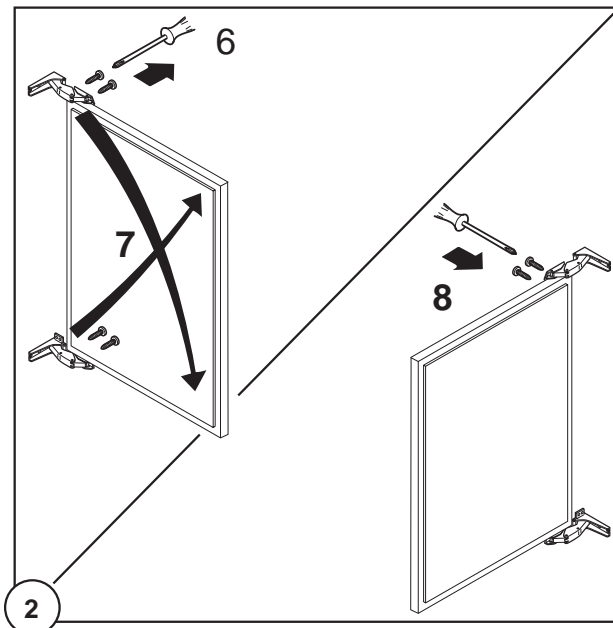
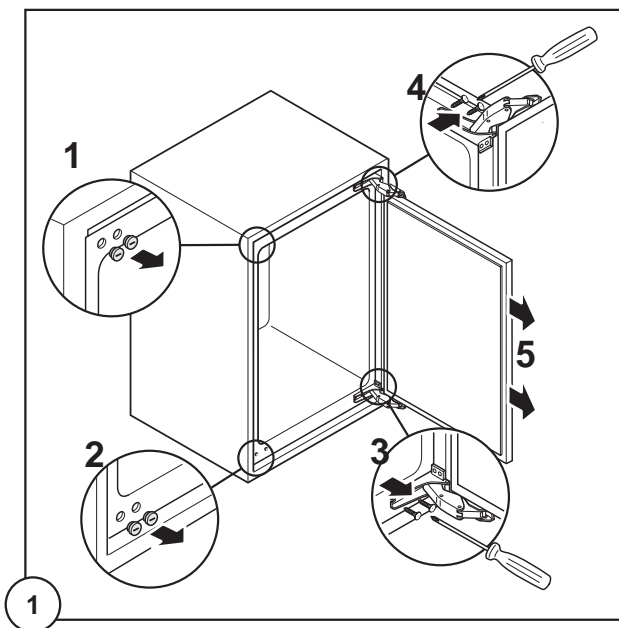



Attention

After completion of the door reversing operation, check that the door gasket adheres to the cabinet. If the ambient temperature is cold (i.e. in Winter), the gasket may not fit perfectly to the cabinet. In that case, wait for the natural fitting of the gasket or accelerate this process by heating up the part involved with a normal hairdryer on a low setting.

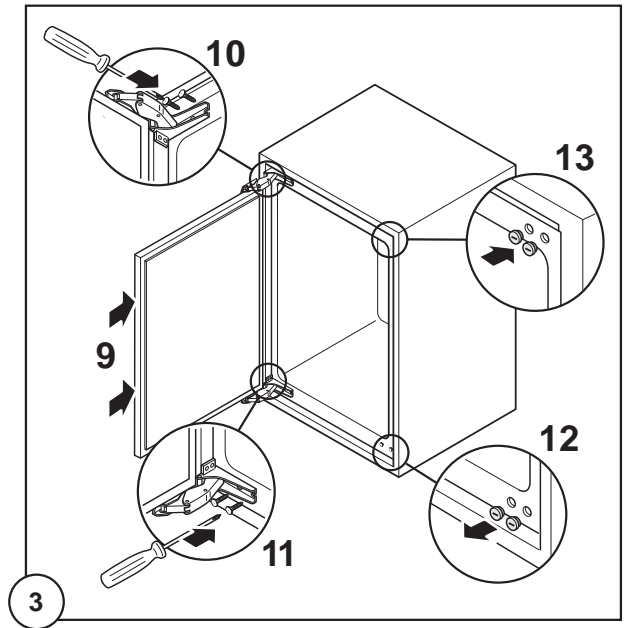

Building the appliance in under a worktop

1. The dimensions of the recessed installation area must correspond with those indicated in the figure.

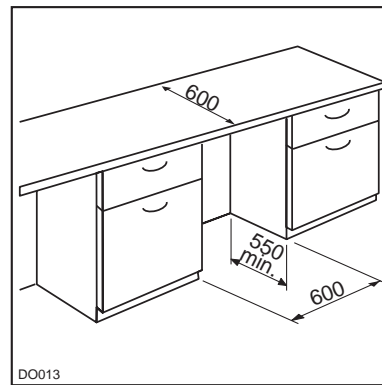

2. Installation kit

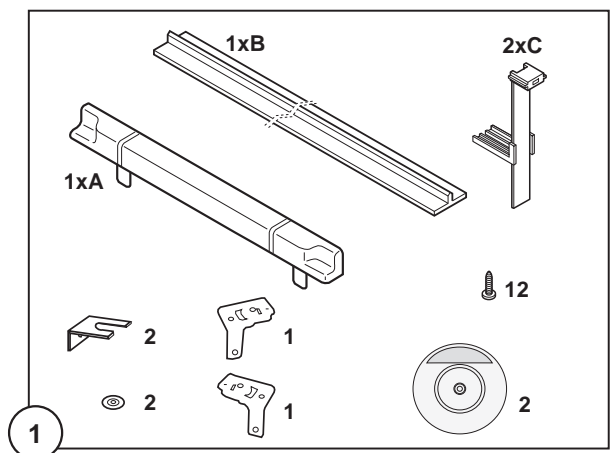

3. Two cabinet securing brackets are supplied with the installation pack. They need to be assembled onto the cabinet prior to cabinet being pushed into the Kitchen aperture.

- To fit these brackets remove the two screws at the top left and right hand front corners of the cabinet.
- Position the two brackets as shown in the figure and replace the two securing screws.

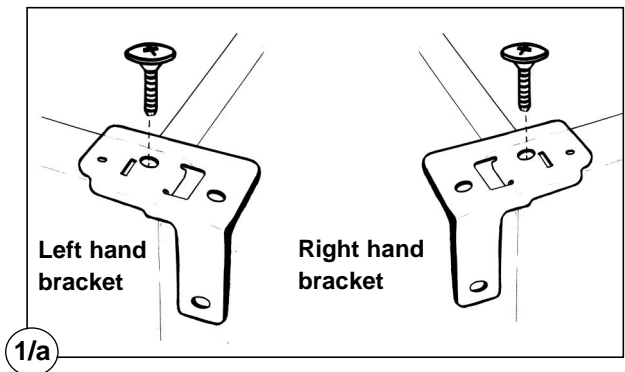

4. Push the appliance into place. The plug socket necessary for connection of the appliance to the electricity supply should be positioned, so that the plug is not placed in the recess.

5. To adjust the height proceed as follows:

- Loosen or tighten the two front feet.
- The rear feet are adjusted by turning the screw in the front kick plate to the left or right.

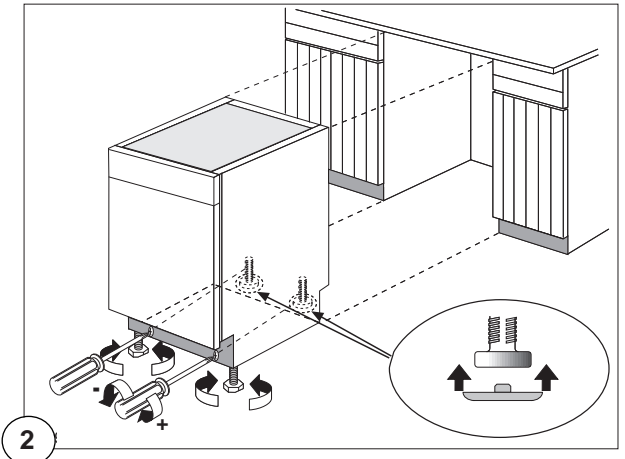

6. If necessary, pads are supplied for the rear feet to make sliding the appliance in and out of the recess easier. To fit the pads, press them onto the rear feet.

If required, the dimensions of these pads can be reduced by breaking them where marked.

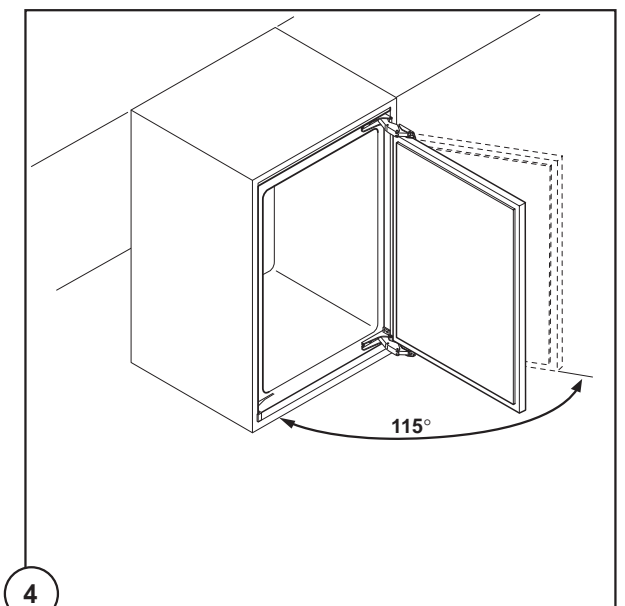
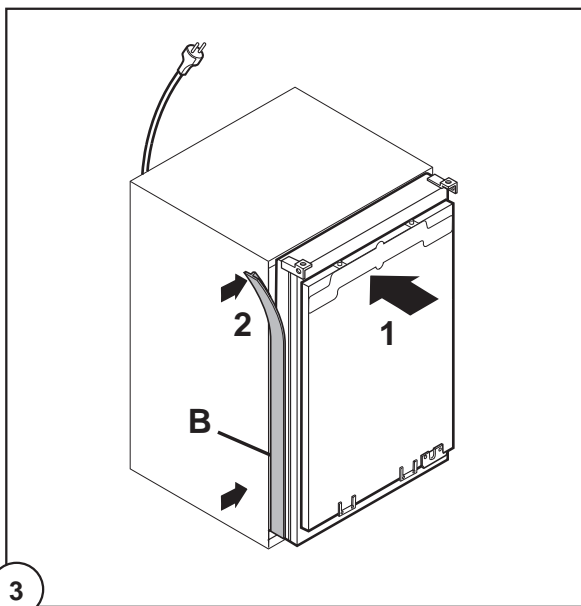
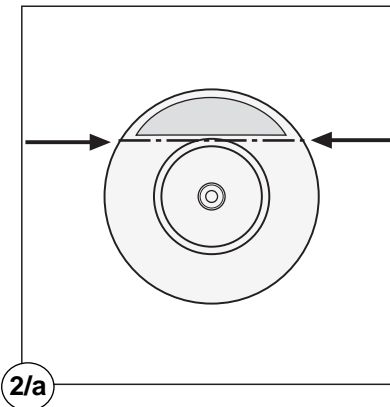

7. Screw appliance into place and retain the cabinet with screws through the securing brackets into the worktop or adjacent woodwork as necessary.

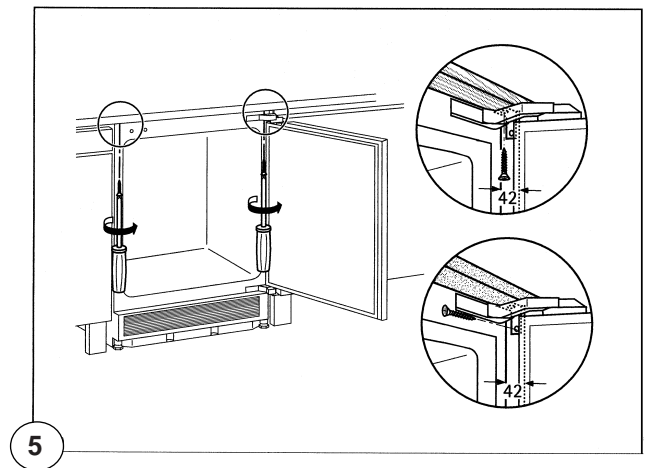

8. To mount the furniture door proceed as shown in the figures:

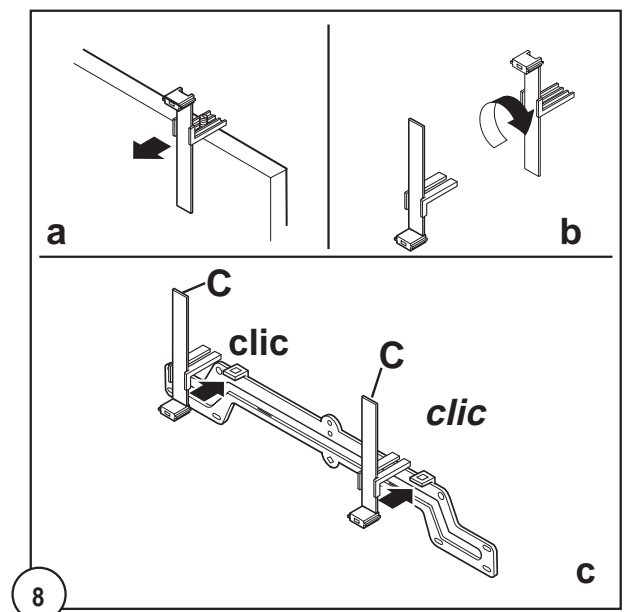
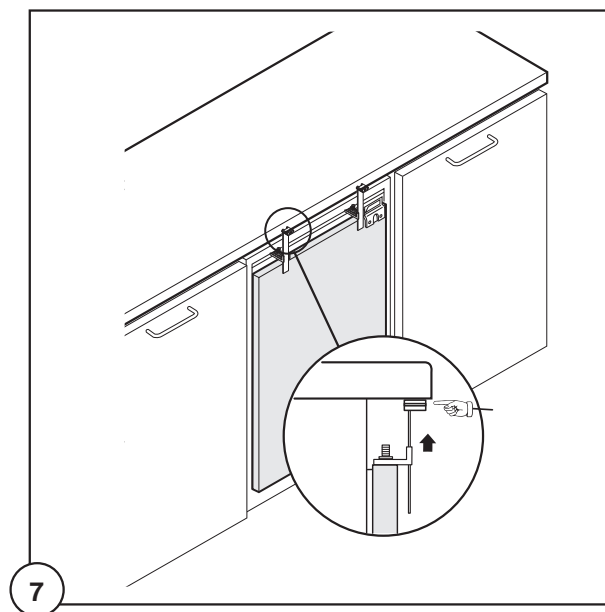
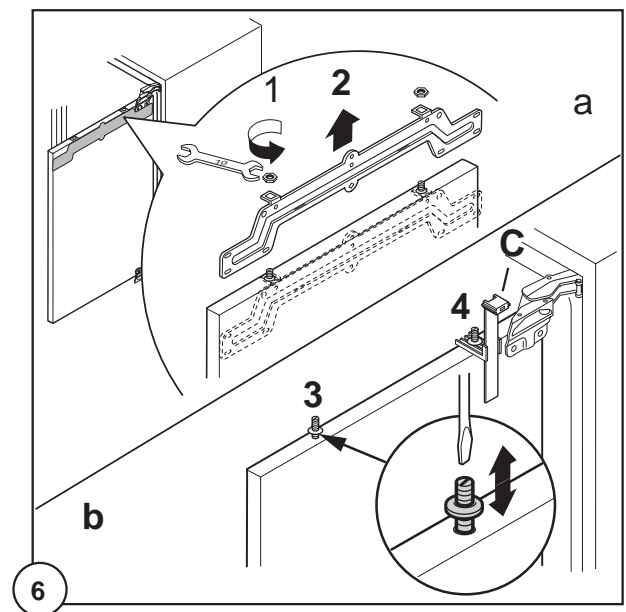

UPPER PART OF KITCHEN FURNITURE PANEL

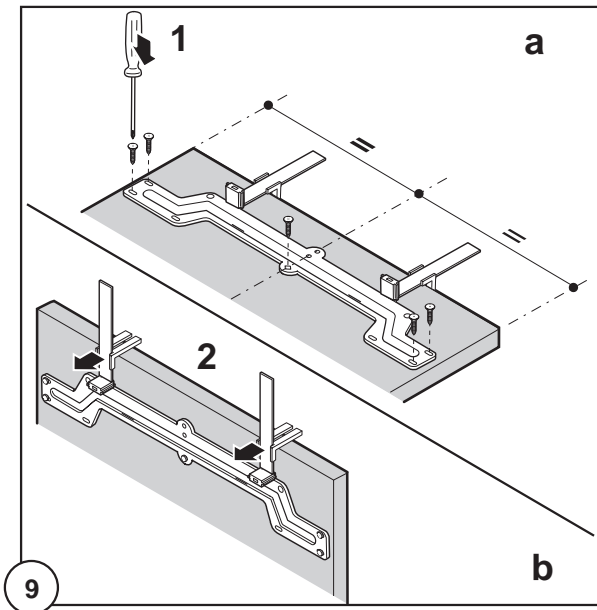

LOWER PART OF KITCHEN FURNITURE PANEL

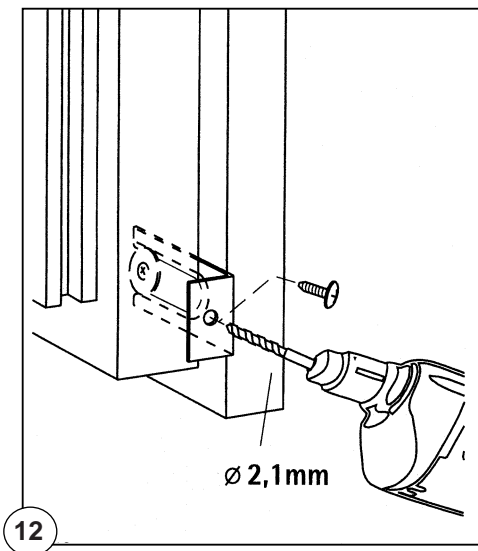
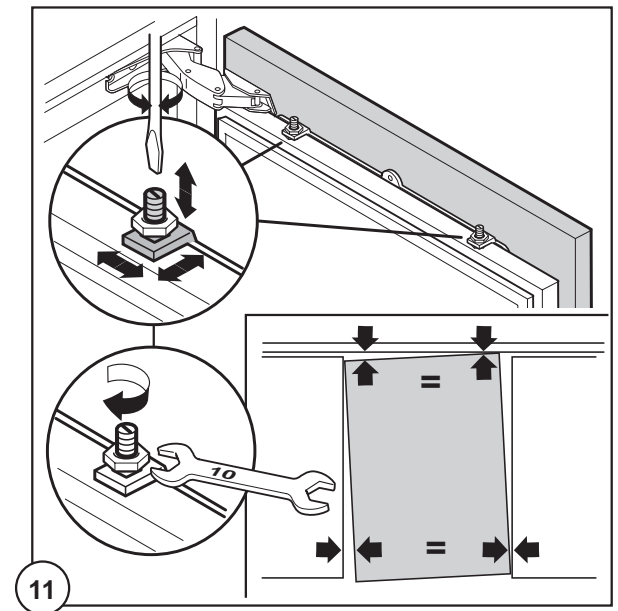
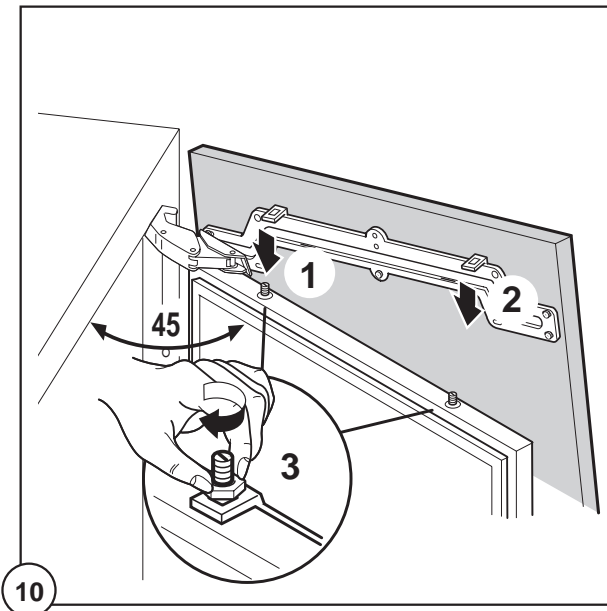
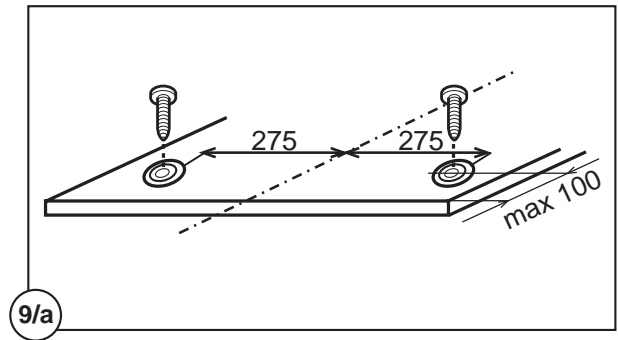

9. Refit the covering strip.

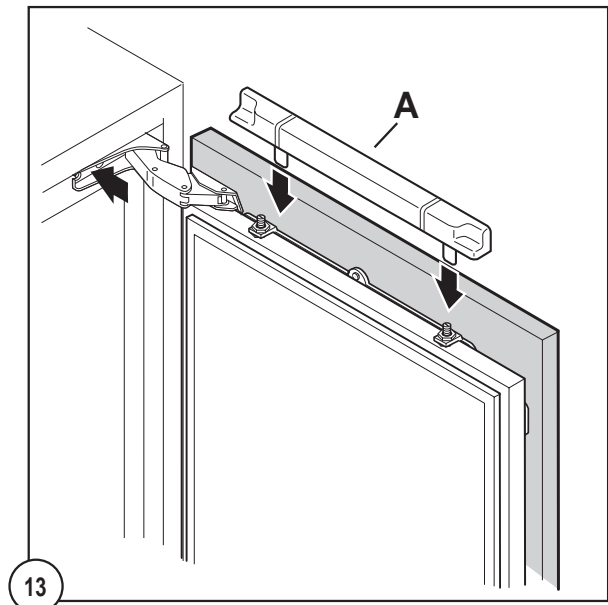

Fitting the plinth



Important

For the efficient operation of the appliance, it is important that the original ventilation grid is used.

- For an opening height dimension $A=820$ mm and a plinth height dimension $a=100$ mm, the plinth may be fitted without adjustments. The same applies to an opening height dimension $B=870$ mm and a plinth height dimension $b=150$ mm.
- For plinth heights greater than $a=100$ mm, $b=150$ mm, a cut should be made in the plinth, 580 mm wide, in the centre of the appliance position, leaving a remaining height of $a=100$ mm, $b=150$ mm.
- Attach plinth to the kitchen units.



Important

The plinth must be positioned at a minimum distance of 25 mm from the door.

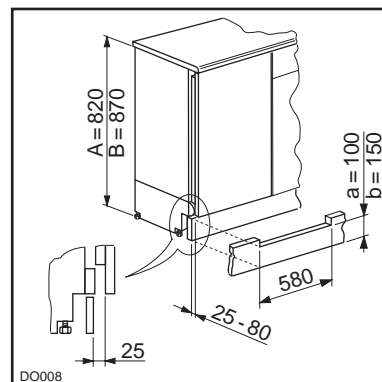

 **The Electrolux Group.** *The world's No.1 choice.*

The Electrolux Group is the world's largest producer of powered appliances for kitchen, cleaning and outdoor use. More than 55 million Electrolux Group products (such as refrigerators, cookers, washing machines, vacuum cleaners, chain saws and lawn mowers) are sold each year to a value of approx. USD 14 billion in more than 150 countries around the world.