

EF36, IF36 & PF36

dacor
The Life of the Kitchen.®

Revised
11/13/07

36" Wide Bottom Freezer Refrigerator

1/2

PLANNING GUIDE

PRODUCT DIMENSIONS

- ◇ The depth from the front of the door (w/o door handles) to the back of the refrigerator chassis is 26 7/8" (683 mm).
- ◇ The depth of the cabinet less the door is 24 1/8" (613 mm).
- ◇ The power cord is 60" (1524 mm) long.
- ◇ The height from the top of the refrigerator to the floor with the leveling legs in the down position is 70 1/8" (1781 mm)
- ◇ The height from the top of the refrigerator to the floor with the leveling legs in the fully extended position is 71 1/4" (1810 mm) at the front of the unit and 70 11/16" (1796 mm) at the rear of the unit.
- ◇ The refrigerator width from edge to edge is 35 5/8" (905 mm).

DOOR SWING DIMENSIONS

The area to the left and the right of the appliance must permit both doors to open to a minimum of 90°. Allow a minimum of 2 1/2" (64 mm) space between the side of the refrigerator doors and a corner wall.

CABINET LAYOUT

- ◇ A grounded three prong non-GFCI electrical outlet must be provided and should be in a location that allows the refrigerator to be connected without an extension cord. See "Electrical Requirements" for additional information.
- ◇ The plumbing for the water line can come through the floor flush to or from the back wall. Install the water valve in a location that allows it to be turned off without moving the refrigerator out in the event the refrigerator or water line requires service.
- ◇ For model IF36, see document 100504 for instructions on planning and installing integrated front panels. It is available at www.Dacor.com.

WATER SUPPLY REQUIREMENTS

- ◇ All installations must meet local plumbing code requirements.
- ◇ Use 1/4" (6 mm) copper line to connect the refrigerator to the house cold fresh water supply.
- ◇ Install a shut off valve between the refrigerator and water supply. The shut off valve should be a drilled saddle valve. See the diagram above for recommended location.
- ◇ Do not use a piecing type or 3/16" (4.76 mm) saddle valve which will reduce water flow and clog more easily.
- ◇ Allow a minimum of 24" (610 mm) diameter service loop of copper tubing outside the wall or floor for easy connection to the water supply.

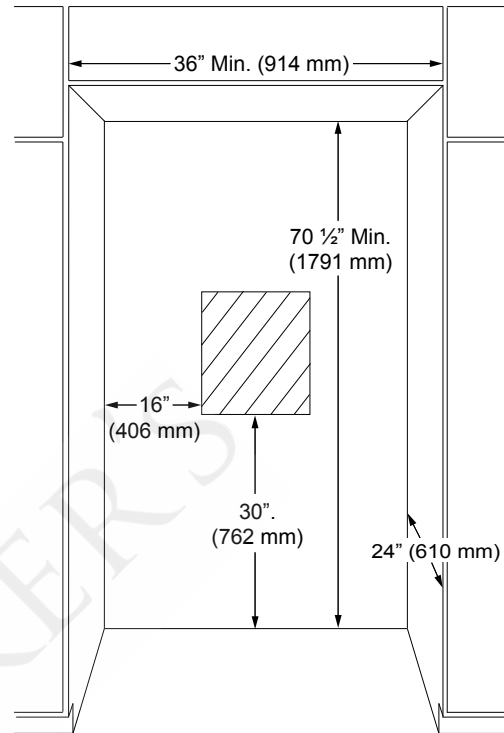

Water Valve Location - Approximate Dimensions

Cold water supply

Connect the ice maker to a cold water line with water pressure between 35 and 120 psi. If you have any questions about your water pressure, call your utility company.

Reverse osmosis water supply

IMPORTANT: The pressure of the water supply coming out of a reverse osmosis system going to the water inlet valve of the refrigerator needs to be between 35 and 120 psi (241 and 827 kPa).

If a reverse osmosis water filtration system is connected to your cold water supply, the water pressure to the reverse osmosis system needs to be a minimum of 40 to 60 psi (276 to 414 kPa).

If the water pressure to the reverse osmosis system is less than 40 to 60 psi (276 to 414 kPa):

- Check to see whether the sediment filter in the reverse osmosis system is blocked. Replace the filter if necessary.
- Allow the storage tank on the reverse osmosis system to refill after heavy usage.
- If your refrigerator has a water filter, it may further reduce the water pressure when used in conjunction with a reverse osmosis system. Remove the water filter. See "Water Filtration System."

If you have questions about your water pressure, call a licensed, qualified plumber.

EF36, IF36 & PF36

dacor
The Life of the Kitchen.®

Revised
11/13/07

36" Wide Bottom Freezer Refrigerator

2/2

PLANNING GUIDE

ELECTRICAL REQUIREMENTS

A 115 Volt, 60 Hz. AC only 15 or 20 amp fused, grounded electrical supply is required. It is recommended that a separate circuit serving only your refrigerator be provided. Use an outlet that cannot be turned off by a switch. Do not use an extension cord.

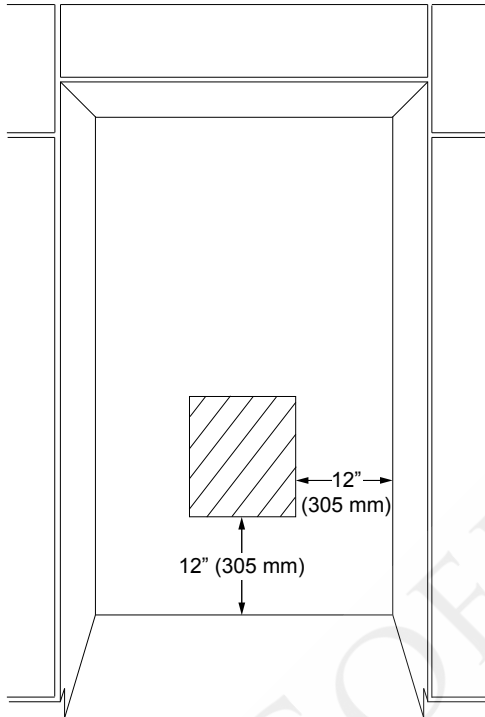

**ELECTRICAL LOCATIONS -
APPROXIMATE DIMENSIONS**