



IMI CORNELIUS REMCOR INC ■ 500 REGENCY DRIVE ■ GLENDALE HEIGHTS, IL 60139-2268

Telephone (800) 551-4423

Facsimile (800) 519-4423

Operator's Manual

CHILLER ("CH" SERIES)

Models: CH750, CH751, and CH951



Part No. 91256
Revision Date: August 9, 2002
Revision: C

THIS DOCUMENT CONTAINS IMPORTANT INFORMATION

This Manual must be read and understood before installing or operating this equipment

TABLE OF CONTENTS

INSTALLATION INSTRUCTIONS	2
Location	2
Plumbing	2
Electrical	2
START-UP/OPERATION	2
MAINTENANCE	3
SERVICE	3
Removing Wrapper	3
Replacing Switch	3
Replacing Standard Thermostat	3
Replacing Electronic Differential Thermostat	4
Replacing Fan Blade and/or Motor	4
Replacing Pump	4
FLUID RECOMMENDATION	5
TROUBLESHOOTING GUIDE	6
Chiller Does Not Operate	6
No Circulation of Chilled Water	6
Inadequate Cooling	6
PARTS LIST	7
WARRANTY	8

LIST OF FIGURES

FIGURE 1. CH750, CH751 AND CH951 EXPLODED VIEW	7
---	----------

INTRODUCTION

The REMCOR “CH” Series Water Chillers (Models CH750–A, CH751–A, and CH951–A) are specifically designed to cool clean liquid before it is circulated to the cooling application. The Unit includes a complete refrigeration system and associated controls housed in a sturdy sheet metal enclosure with perforated panels for air circulation. Options include a reservoir and a choice of pumps and temperature controls to provide a self-contained liquid cooling/circulation system tailored to a particular closed loop or tank cooling application.

On closed loop systems, the Unit is provided with a pump and reservoir for recirculation of water from the chiller to the process. On tank cooling systems, the Unit is provided without the reservoir and the pump is optional for recirculation of water from the chiller to the tank. Control temperature is sensed on the outlet of the chiller for closed loop systems and it is sensed on the inlet of the chiller for tank cooling systems.

The temperature control options consist of a general purpose digital thermostat and an electronic differential thermostat to satisfy the temperature control requirements. Both options include a digital thermometer for monitoring system temperature.

The pump options consist of a small magnetic drive pump as standard with a variety of magnetic drive and positive displacement pumps available for particular flow and pressure requirements. An optional bypass valve is available for the pump circulation system. (This valve is standard on Units utilizing the positive displacement pumps). This can be used to adjust pump flow and pressure to match process requirements. This valve also allows internal recirculation within the chiller in the event the chiller outlet is obstructed.

SPECIFICATIONS

	CH750–A	CH751–A	CH951–A
Condensing Unit Horse Power	3/4	3/4	1
Electrical (Volts/Phase/Hz)	115/1/60	230/1/60	230/1/60
F.L.A. (Amps)	17	8.5	10
Reservoir Capacity (Gal)	5	5	5
Refrigerant 134–A Charge (Lbs)	3.5	3.5	4.0
Stainless Steel Connections	3/4–inch FPT	3/4–inch FPT	3/4–inch FPT
Operating Water Temperature Range	40°F-100°F	40°F-100°F	40°F-100°F
Net Weight (Lbs)	175	175	175
Dimensions Depth (inches)	24–1/2	24–1/2	24–1/2
Width (inches)	18–1/8	18–1/8	18–1/8
Height (inches)	30–1/2	30–1/2	30–1/2

INSTALLATION INSTRUCTIONS

LOCATION

Locate the chiller indoors in a well ventilated area with ambient temperatures in the range of 65° F to 100° F. Allow a minimum of six inches of clearance around the chiller for proper air circulation. Avoid hot air discharge from other equipment or enclosed areas where heat could build up and cause a rise in ambient temperature.

PLUMBING

Follow standard plumbing practices and local codes in making water connections. Piping that is exposed to high ambient temperatures may need to be insulated to prevent condensation and/or significant liquid heat gain.

ELECTRICAL

All wiring must conform to the National Electric Code and any applicable local codes. The chiller must be:

- 1) Permanently wired by means of conduit from the junction box on the rear of the chiller cabinet to a properly fused disconnect of proper amperage or:
- 2) Wired to a properly rated power cord and plugged into an outlet with appropriate disconnect and amperage rating.

START-UP/OPERATION

Before the Unit can be operated, it is important that the circulating system be filled with water (See Fluid Recommendations page). On systems with a reservoir, ensure that the drain plug is in place and the plug is secure. Fill the reservoir through the fill port with clean water. The water level sight glass on the front panel will indicate "Full" when enough water has been added. Once full, make the final connection to the inlet and outlet of the chiller. On system without a reservoir, the pump should be primed before operation. Attach a water source to the inlet of the chiller and fill the Unit with clean water. The system is filled when the water can be seen flowing at the chiller outlet. Once full, make the final connection to the inlet of the chiller.

Turn the power switch to the "On" position. The switch will light indicating power to the Unit and the pump will operate, the thermostat can be adjusted to the proper setpoint.

Set the standard digital thermostat to the desired setpoint as follows:

- 1) Push the "Set" button located to the right of the digital display. The current setpoint will show on the display.
- 2) While the current setpoint is displayed, push the "Up" or "Down" buttons until the desired setpoint shows on the display.
- 3) Release all buttons. The display will show the system water temperature after a few seconds. The setpoint can be viewed at any time by merely pushing the "Set" button.

If the Unit is provided with the electronic differential thermostat, the air probe will need to be located where ambient temperature is to be monitored. The setpoint will then be the temperature of the air probe. If this thermostat is provided with a digital display, the setpoint can be checked by pushing the "Setpoint" button located on the display. Releasing this button will display the system water temperature.

When the flow rate to the process is critical, a flow meter and valve should be installed in the line in order to obtain the proper flow rate.

Once these start-up procedures are complete, the chiller is ready for standard operation.

NOTE:

- 1) **Never operate the chiller with enclosure panels removed.**
- 2) **Always use the illuminated switch to turn off the chiller when it is not being used.**
- 3) **Always ensure that all air inlets and outlets are free of obstructions.**

MAINTENANCE



WARNING: Disconnect electrical power from the Unit before performing any of the following maintenance procedures.

The chiller requires very little normal maintenance. The condenser fins should be cleaned by blowing compressed air through the condenser, from the fan side as required to prevent blockage of air flow by dirt and debris that may accumulate over time. The condenser fan motor should be lubricated every six months with a few drops of SAE 10 oil. The positive displacement pump motor should be lubricated with ten drops of SAE 20 oil once each year. The circulation system should be drained and flushed periodically to avoid build up and possible restriction of flow by contaminants. Following these simple procedures will ensure many trouble free hours of chiller operation.

SERVICE

Service of the chiller is limited to replacing the switch, the thermostat, the fan motor, and the pump. Charging and other refrigeration problems *must* be performed by a qualified refrigeration technician.

REMOVING WRAPPER

1. Disconnect electrical power from the Unit.
2. Remove the seven screws from each side of the wrapper and the two screws that secure the wrapper to the front and back panels. Retain all hardware and lift the wrapper off the Unit.

REPLACING SWITCH

1. Remove the wrapper as specified in REMOVING WRAPPER.
2. Remove the spade lugs from the existing switch and note connection points.
3. Remove the switch from the front panel.
4. Install the new switch in the front panel and connect the leads to the new switch.
5. Install the wrapper.

REPLACING STANDARD THERMOSTAT

1. Remove the wrapper as specified in REMOVING WRAPPER.
2. Loosen the screw terminals securing the wires at the rear of the thermostat. Note connection points and remove the wires.
3. Remove the screw securing the mounting bracket to the back of the thermostat.
4. Remove the thermostat from the front panel.

5. Install the new thermostat in the front panel and secure it with the mounting bracket.
6. Reconnect the wires at back of the thermostat.
7. Install the wrapper.

REPLACING ELECTRONIC DIFFERENTIAL THERMOSTAT

1. Remove the wrapper as specified in REMOVING WRAPPER.
2. Remove the two screws securing the thermostat cover and remove the cover.
3. Loosen the screw terminals securing all wires to the thermostat. Note connection points and remove the wires.
4. If the Unit is provided with a digital display, the ribbon cable should be removed from the thermostat. The display can be replaced by depressing the plastic clips and removing it from the front panel.
5. Remove the two screws securing the thermostat to the fan shroud and remove the thermostat.
6. Secure new thermostat to the fan shroud, then re-connect all wires and ribbon cable. Replace cover.
7. Install the wrapper.

REPLACING FAN BLADE AND/OR MOTOR

1. Remove the wrapper as specified in REMOVING WRAPPER.
2. Remove the screws securing the fan guard to the fan shroud.
3. Remove the conduit connection at the back of the motor and disconnect the wire leads.
4. Remove the bolts securing the fan mounting bracket to the base and remove the fan/motor assembly.
5. Separate the fan blade from the motor and install the new blade or motor.
6. Re-install the fan mounting bracket and fan guard. Re-connect the wire leads and conduit connection.
7. Install the wrapper.

REPLACING PUMP

1. Remove the wrapper as specified in REMOVING WRAPPER.
2. Remove the clamps and hoses from the suction and discharge of the pump.
3. Remove the screws securing the pump to the base.
4. Disconnect the wire leads from the pump motor and remove the pump.
5. Remove all fittings from the pump and install them on the new pump.
6. Install the pump and re-connect wire leads and hoses.
7. Install the wrapper.

FLUID RECOMMENDATION

Remcor Chillers are designed to operate with water to provide maximum performance for temperatures of 40°F–100°F.

Distilled Water	Acceptable
De-Ionized Water (1–5 MEG/OHMS)	Acceptable
De-Ionized Water (5+MEG/OHMS)	Acceptable with Stainless Steel & PVC only *No Copper or Brass
Propylene Glycol (Lab & Industrial Grade)	Acceptable – 30% Glycol/70% Water *For Applications with Temperatures below 40°F
Lab & Industrial Grade Ethylene Glycol	Acceptable – 30% Glycol/70% Water *For Applications with Temperatures below 40°F
Mineral/Hydraulic Oils (Viscosity<50 Centistrokes)	Acceptable
Ethylene Glycol (Commercial/Automotive Antifreeze)	NOT Acceptable *Silicate Rust Inhibitors in Automotive/Commercial Antifreeze will damage pump seals and housing which lead to failure.
Acidic/Basic Solutions (Above 8/Below 6 PH)	Not Acceptable
Mineral/Hydraulic Oils (Viscosity>50 Centistrokes)	Not Acceptable

For questions regarding special or other fluids contact IMI Cornelius Remcor at 800–551–4423.

To Purchase Lab or Industrial Glycol contact:

Hubbard Hall	(800) 648–3412 – Dow Therm SR1 available in 5 gallon
IMI Cornelius	(800) 551–4423 – Part# 111521000 5 gallons

TROUBLESHOOTING GUIDE

Trouble	Probable Cause	Remedy
CHILLER DOES NOT OPERATE	A. No power.	A. Check fuse or circuit breaker.
	B. Loose or poor wire connection.	B. Check wiring. Correct for loose or poor wire connection.
	C. Inoperable ON–OFF switch.	C. Replace ON–OFF switch.
	D. Overload device open.	D. Allow compressor to cool, then install new overload device; replace compressor if necessary.
	E. Inoperable relay.	E. Replace relay.
	F. Low input voltage.	F. Nominal voltage $\pm 10\%$ is required.
NO CIRCULATION OF CHILLED WATER	A. Vinyl tubing kinked.	A. Check tubing and remove kinks.
	B. Low water level.	B. Ensure that tank is full.
	C. Inoperable pump.	C. Check for obstruction or binding impeller, replace pump and/or motor if necessary.
INADEQUATE COOLING	A. Condenser fins dirty.	A. Blow dirt out of fins.
	B. Fan motor not operating freely.	B. Lubricate and hand spin until fan rotates freely; replace fan blade and/or motor if necessary.
	C. Water not circulating	C. See “NO CIRCULATION OF CHILLED WATER”.
	D. Low refrigerant level.	D. Charge system with refrigerant.
	E. Inoperative temperature control.	E. Replace thermostat.

PARTS LIST

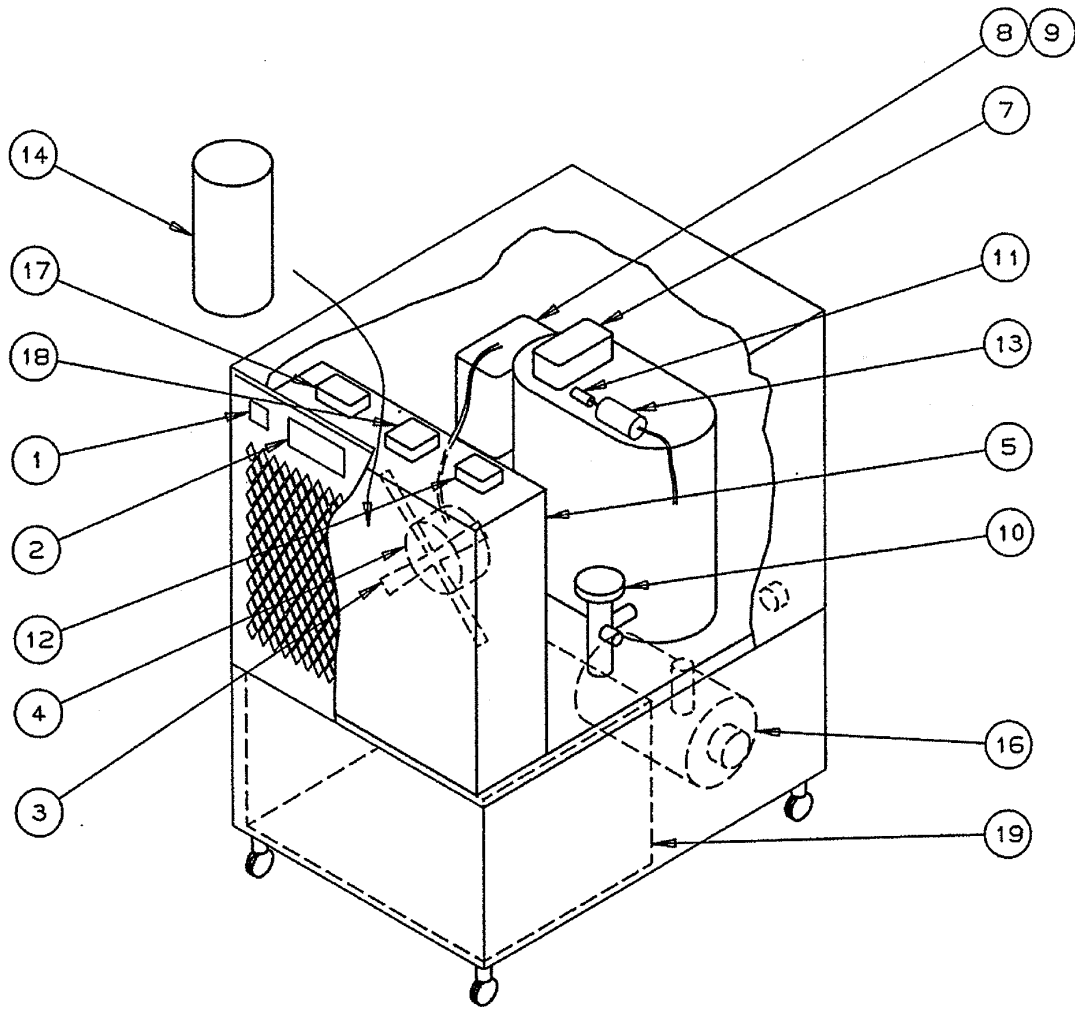

FIGURE 1. CH750, CH751 AND CH951 EXPLODED VIEW

Item No.	Part No.	Name
1	31934	Switch, Illuminated
	31935	Switch, Illuminated
2	32386	Thermostat, Eliwell No. EWPC902
3	620603708	Blade, Fan
4	620603711	Motor, Fan (CH550)
	620603712	Motor, Fan (CH750)
	620603713	Motor, Fan (CH551)
5	*	Condenser
6	Not Used	
7	620603701	Compressor (CH550)
	620603702	Compressor (CH551)
	620603703	Compressor (CH750)
	620603704	Compressor (CH751)

	620603705	Compressor (CH951)
8	*	Relay
9	*	Capacitor
10	61058, 61001	TXV CH750, CH751
	61003	TXV CH951
11	60514	Sight Glass
12	60502	Control, Low Pressure
13	61002	Filter Drier
14	*	Receiver
15		Not Used
16	*	Pump, Circulating
17	32378	Transformer, Thermostat
18	*	Evaporator Assembly

***CONTACT THE SERVICE DEPARTMENT FOR THE APPROPRIATE PART NUMBERS**

WARRANTY

IMI Cornelius Inc. warrants that all equipment and parts are free from defects in material and workmanship under normal use and service. For a copy of the warranty applicable to your Cornelius, Remcor or Wilshire product, in your country, please write, fax or telephone the IMI Cornelius office nearest you. Please provide the equipment model number, serial number and the date of purchase.

IMI Cornelius Offices

AUSTRALIA • P.O. 210, • RIVERWOOD, • NSW 2210, AUSTRALIA • (61) 2 533 3122 • FAX (61) 2 534 2166
AUSTRIA • AM LANGEN FELDE 32 • A-1222 • VIENNA, AUSTRIA • (43) 1 233 520 • FAX (43) 1-2335-2930
BELGIUM • BOSKAPELLEI 122 • B-2930 BRAASCHAAT, BELGIUM • (32) 3 664 0552 • FAX (32) 3 665 2307
BRAZIL • RUA ITAOCARA 97 • TOMAS COELHO • RIO DE JANEIRO, BRAZIL • (55) 21 591 7150 • FAX (55) 21 593 1829
ENGLAND • TYTHING ROAD ALCESTER • WARWICKSHIRE, B49 6 EU, ENGLAND • (44) 789 763 101 • FAX (44) 789 763 644
FRANCE • 71 ROUTE DE ST. DENIS • F-95170 DEUIL LA BARRE • PARIS, FRANCE • (33) 1 34 28 6200 • FAX (33) 1 34 28 6201
GERMANY • CARL LEVERKUS STRASSE 15 • D-4018 LANGENFELD, GERMANY • (49) 2173 7930 • FAX (49) 2173 77 438
GREECE • 488 MESSOGION AVENUE • AGIA PARASKEVI • 153 42 • ATHENS, GREECE • (30) 1 600 1073 • FAX (30) 1 601 2491
HONG KONG • 1104 TAIKOTSUI CENTRE • 11-15 KOK CHEUNG ST • TAIKOKTSUE, HONG KONG • (852) 789 9882 • FAX (852) 391 6222
ITALY • VIA PELLIZZARI 11 • I-20059 • VIMARCA, ITALY • (39) 39 608 0817 • FAX (39) 39 608 0814
NEW ZEALAND • 20 LANSFORD CRES. • P.O. BOX 19-044 AVONDALE • AUCKLAND 7, NEW ZEALAND • (64) 9 8200 357 • FAX (64) 9 8200 361
SINGAPORE • 16 TUAS STREET • SINGAPORE 2263 • (65) 862 5542 • FAX (65) 862 5604
SPAIN • POLIGONO INDUSTRIAL • RIERA DEL FONOLLAR • E-08830 SANT BOI DE LLOBREGAT • BARCELONA, SPAIN • (34) 3 640 2839 • FAX (34) 3 654 3379
USA • ONE CORNELIUS PLACE • ANOKA, MINNESOTA • (763) 421-6120 • FAX (763) 422-3255

LD004
4/21/98

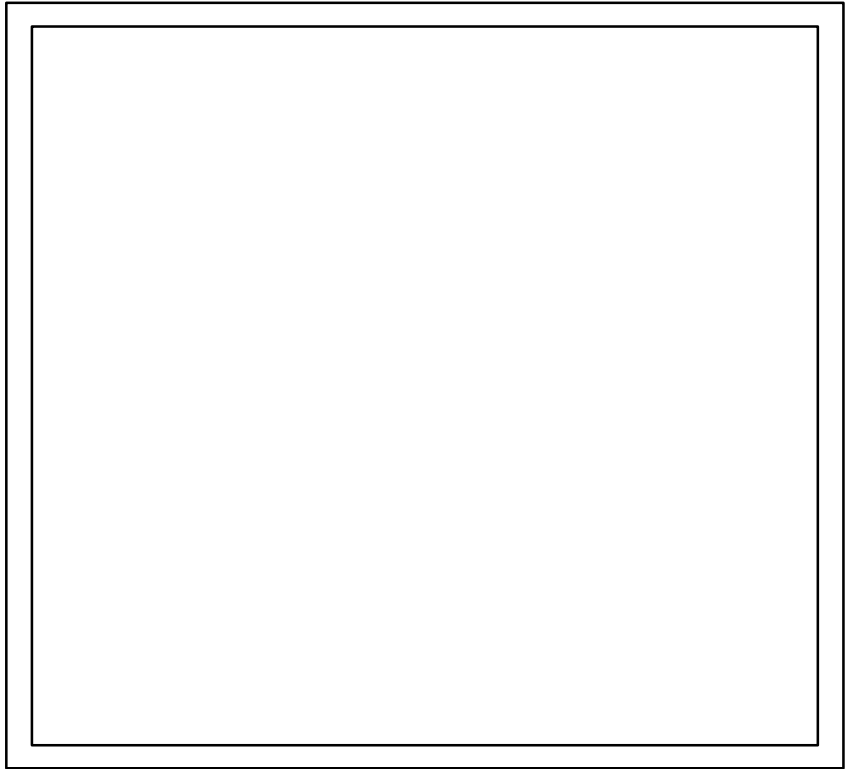

REMCOR[®]

CORPORATE HEADQUARTERS:

Remcor Incorporated
500 Regency Drive
Glendale Heights, IL 60139