



Phone: 317-337-9813 Fax: 317-337-9816
www.continentalchillers.com

UniPacTM Single Phase

Air Cooled Chillers
Water Cooled Chillers
Split System Chillers

3 through 60 HP



**Shown, model USAC-8
Packaged Air Cooled Chiller with
Factory Mounted Chiller Pump**



**Typical Scroll
Compressor**



Introducing UniPac™ Chiller Systems

All over the world, **Continental** has successfully developed and marketed various packaged and split chillers to serve many needs. For several years discerning Engineers, Contractors, and Owners have expressed a desire to specify, install and own **Unique Single Phase** quality chillers in sizes ranging from 3 to 60 HP.

This need is being fulfilled by **Continental's** line of **UniPac™** Chillers.

UniPac™ chillers have a full compliment of factory installed and wired optional accessories. These accessories can save several hundreds of dollars in field labor and material, resulting in cost effective installation.

Packaged **UniPac™** chillers are factory tested and shipped with a vapor charge of R-22.

Split **UniPac™** chillers are "dry run" tested for functional tests and shipped with dry air or nitrogen for field piping evacuating and refrigerant charging.

Packaged Air Cooled and Water Cooled Systems	Split Air Cooled Systems
To order Packaged Air Cooled Chiller: Use model USAC	To order Split (A) Compressor, Chiller, Control Panel – model USC with matching Outdoor Air Cooled Condenser – model CAD
To order Packaged Water Cooled Chiller: Use model USWC	To order Split (B) Compressor/Condenser (Condensing Unit) Outdoor – model USA with matching Indoor Chiller – model CDX

UNIPAC™ NOMENCLATURE

Packaged Air Cooled and Water Cooled Chiller Systems

U S AC or WC – X

U	Unique
S	Scroll
AC	Condenser – Air Cooled
WC	Condenser – Water Cooled
X	Nominal Horse Power - 3, 4*, 5, 8*, 10, 12*, 15, 20, 25, 30, 40, 50, 60

*For 4, 8, 12 Ton Ratings, Contact Factory

Ordering Examples: 40 ton packaged Single Phase Air Cooled Chiller, **model USAC-40**

30 ton packaged Single Phase Water Cooled Chiller, **model USWC-30**

20 ton split Single Phase Air Cooled Chiller, option A, models **USC-20 (indoor compressor/chiller)** and **CAD-20 (outdoor A/C condenser)**

20 ton split Single Phase Air Cooled Chiller, option B, models **USA-20 (outdoor condensing unit)** and **CDX-20 (indoor chiller)**



Standard Unit Specifications of UniPac™ Single Phase Chillers

General Description

Continental's Single Phase Air and Water Cooled Chillers are packaged systems complete with scroll compressor(s), air cooled or water cooled condenser(s), individual cooler/evaporator(s), independent refrigerant circuit(s) and a control center all mounted on a heavy duty structural steel frame.

Scroll Compressor(s)

Compressors are well proven state-of-the-art scrolls with fewer moving parts, less rotating mass, and less internal friction than *traditional* reciprocating compressors.

Motor is suction gas-cooled, hermetically sealed, two pole, squirrel cage induction type and is directly driven at 3600 rpm.

All compressor(s) are mounted on resilient pads to minimize vibration.

Air Cooled Condenser for Air Cooled Models

Condenser Coil-industrial quality, seamless copper tube

Fins-all aluminum, die formed with full self-spacing collars that completely cover the copper tube; fins are mechanically bonded to the copper tubes

Propeller Fans-large surface, low speed, low sound level propeller fans for vertical airflow; fans are statically and dynamically balanced and operate at low tip speeds for low vibration and sound levels

Fan Guards- PVC coated for long life

Fan Venturi- high collar fully spun venturi design for high efficiency and low outlet noise

Fan Motors-special "enclosed air over" motor design with built-in overload protection; single phase motors operate at a low speed of 1075 rpm

Water Cooled Condenser for Water Cooled Models

Each water cooled condenser is of shell/coil design. The condenser water flows through special heat transfer copper tube. Refrigerant flows through the steel shell and a built in receiver.

Cooler/Evaporator for All Models

Each cooler/evaporator is of shell/coil design. The water to be chilled flows through special heat transfer copper tube. Refrigerant flows through the steel shell/receiver.

Refrigerant Piping

Each Refrigerant circuit includes:

- Liquid line with charging connection
- Filter drier
- Liquid solenoid valve with 115 V coil (220 V or 24 V, optional)

- Sight glass/ moisture indicator
- Suction line fully insulated, designed for proper oil return at minimum friction loss
- Discharge line formed of clean ACR type tubing and pre-formed radius fitting

Control Center

All power, starting, safety and operating controls are mounted in a built in fully enclosed, weather proof control panel for air cooled models and NEMA-1 enclosures for indoor water cooled or condenserless models.

Power controls include:

- Single point electrical terminal block for 230/1/60 power input
- Compressor-motor contactor(s)
- Compressor run capacitor(s)
- Fan motor contactor(s) (air cooled units only)
- Control circuit fuse
- Control circuit terminal block

Safety/Operating controls include:

- Two position switch indicating *off/system on* – per circuit
- High Pressure control with manual reset –per circuit
- Low pressure control with auto reset – per circuit
- Adjustable chilled water temperature controller
- Adjustable freezestat
- Adjustable compressor anti-recycle timer(s)
- Relay(s)
- Built-in compressor-motor overload

Testing, Evacuation and Refrigerant Charging

Each completed system is pressure tested with nitrogen, evacuated with a high capacity vacuum pump, vapor charged with R-22 and fully tested for all operating and safety controls. Field charge of R-22 required.

Split chiller systems are "dry run" tested for operating and safety controls.

Assembly

All above components are assembled on a heavy-duty structural steel frame, formed of channels and angles as a rugged pre-engineered package. Each steel frame has mounting holes and "lifting eyes" on four sides for "spreader bar" lifting and rigging.

The cabinet of air cooled units is made of heavy gauge galvanized steel.



UniPac™ Options and Selection Procedures

1. **Control Transformer** - For applications where a separate 115-volt power source is not available, a transformer can be installed and wired between the line voltage power terminal block and the 115-volt control circuit. Transformer primary fuses are included.
2. **Factory mounted and wired flow switch** - This accessory is mandatory for Continental warranty to be effective. Provides protection from chiller freezing due to "no flow" through chiller-evaporator.
3. **Factory Mounted and Wired Chiller Water Pump/Valve** - Includes chilled water circulating pump, pump starter, and isolation valve. Provides system pump for chilled water circulation- saves field labor and material. This pump is interlocked with the flow switch and "phased in" at the factory for proper rotation.
4. **Non-fused Disconnect** - Factory mounted non-fused disconnect sized for model and voltage. This saves field labor and material.
5. **Low Evaporator Pressure Freezestat** - Senses low evaporator pressure and shuts down system after sixty second time delay. Extra safety protection against low pressure due to gas shortage or freeze conditions.
6. **Pressure Gauges** - Two-inch diameter gauges are factory installed and piped to compressor. High and low pressure for each refrigerant circuit.
7. **Indicator Lights** - Three indicating lights show Power On, High Pressure Fail, and No Flow/Freeze for each refrigerant circuit.
8. **Vibration Isolators** - Level adjusting spring type for one-inch deflection for field mounting-reduces vibration transmission.
9. **Low Ambient Controls** - Standard units have fan cycling and are good for 45°F ambient.
 - a) For Low Ambient of 0°F. Includes a modulating solid state fan speed controller and a single phase condenser motor(s) as well as fan cycling.
 - b) For Low Ambient of -20°F. Includes head pressure control valve in conjunction with oversized heated and insulated receiver(s) and fan cycling. Receiver includes pressure relief valve.
10. **Micro-Processor Controller**
11. **Water Regulating Valve** - Provides head pressure control for water cooled models USWC.
12. **90/10 Cu-Ni Condenser** - For water cooled models, USWC.
13. **Blygold or Heresite Coated Condenser** - Coil is coated with Blygold or Heresite for protection against elements. Minimal effect on heat transfer.
14. **Copper Tube/Copper Fin Condenser Coil** - Seamless copper tube with die formed copper fins, mechanically bonded to the tube. Provides maximum protection from salt-water environment due to the elimination of dissimilar metals.
15. **Complete Unit Coating** - Your choice of paint, Blygold, Imron, polyester or Heresite coating for complete unit.
16. **Stainless Steel Hardware** - For extra protection against corrosion.
17. **Low Speed Condenser Fan Motors** - For lower noise levels
18. **Centrifugal Condenser Fans** - For ducted applications
19. **Acoustical Enclosure** - Compressor is located in an acoustical enclosure providing dampening of sound levels.
20. **Dual Unit Kit** - Allows operation of two or more units
21. **Alarm Bell Contacts** - Allows alarm bell connection to pressure controls for signaling if unit fails on manual reset safety controls. (alarm bell is not included but can be provided)
22. **Water Flange Kit** - Factory or field mounted consists of 150lb raised face flanges to convert male pipe thread to flanged cooler connections.
23. **High Return Water Thermostat** - Factory mounted thermostat senses high return water temperature at start-up. Allows unit to run un-loaded instead of shutting down due to high head pressure
24. **Brine Chilling** - Modified cooler and controls for various brines/glycols/alcohols.
25. **High entering Water Process Cooling** - Secondary plate heat exchanger with pump, factory mounted and wired to protect compressor against burnouts due to high water temperatures.
26. **Potable/Ingredient Water at 34°F** - For bakeries/produce or other applications.
27. **Cooler Heater with Thermostat** - For freeze protection.
28. **Desuperheaters** - Provides "free hot water" by recovering heat from super heated gas.
29. **Compressor Circuit Breaker** - Both fused and non-fused short circuit protection for each compressor, further reducing chance of motor burnout.
30. **Digital Temperature Readout**
31. **Compressor Cycle Counter/Hour Meters**
32. **Non-Ozone Depleting, Environmentally-Friendly Refrigerant**

Ratings and Selection Procedures

1. **Ratings:** are in accordance with ARI standard for chillers. These ratings may be interpolated for any published chilled water temperatures between 40°F and 50°F but must not be extrapolated.
2. **Chilled Water Flow:** based on 2.4 GPM per Ton and 10°F chilled water range. Limit 6°F minimum to 14°F maximum.
3. **Cooler Fouling Factor:** 0.00025 fouling is standard
For 0.0005 fouling capacity correction factor = 0.982 x TR, 0.994 x kW
For 0.00075 fouling capacity correction factor = 0.964 x TR, 0.989 x kW
4. **Water cooled condenser fouling factor:** ratings are based on 0.00025 for condenser. For 0.00075 Condenser tons x 0.97 -kW x 1.045
5. **Copper Fin Ratings:** TR x 1.01 - kW x 0.99
6. **Ethylene Glycol Correction Factors:** Following factors are to be applied to the standard ratings for ethylene glycol. For other glycols consult factory.

% Wt. Ethylene Glycol	Correction Factors				Freeze Point (°F)
	Tons	kW	▲P	GPM/°F/Ton	
10	.995	1.000	1.02	24.1	26
20	.990	0.995	1.05	24.8	16
30	.980	.990	1.10	26.0	5
40	.975	0.985	1.13	27.3	-10
50	.960	0.980	1.18	29.0	-32

Altitude: Ratings are based on altitude of sea level. For other ratings use the following correction factors

Alt. Above Sea Level	Capacity Multiplier	Alt. Above Sea Level	Capacity Multiplier
Sea Level	1.0	4000	.971
1000	1.0	5000	.962
2000	.995	6000	.951
3000	.980	7000	.949

7. For ratings outside this catalog range consult Continental for assistance
Tel:(317)337-9813 Fax:(317)337-9816 E-mail: sales@continentalchillers.com

Selection Procedures

All units are rated in accordance with ARI Standard and cover a wide range of leaving chilled water temperatures and ambients from 85°F to 120°F.

To select any chiller it is necessary to know:

1. Capacity: _____ Tons
2. Entering and leaving chilled water temperature: _____ °F
3. Water Flow: _____ GPM
4. Design ambient temperature: _____ °F or
5. Entering/leaving cond. water temperature, for water cooled units: _____ °F

Knowing any two of items 1,2 or 3, the third can be calculated as follows:

$$\text{GPM} = \frac{\text{Tons} \times 24}{\text{Temp. Rise}(\Delta t)}$$



Single Phase Air Cooled Ratings
Models USAC-3 through USAC-20
3 through 20 Tons

LCWT °F	Model USAC	Ambient Air Temperature °F														
		85			95			105		115			120			
		TR	kW	Cooler GPM	TR	kW	Cooler GPM	TR	kW	Cooler GPM	TR	kW	Cooler GPM	TR	kW	Cooler GPM
40	3	2.6	3.0	6.2	2.3	3.1	5.5	2.1	3.2	5.0	1.8	3.3	4.3	1.6	3.3	3.8
	5	4.3	5.0	10.3	3.9	5.2	9.4	3.5	5.4	8.4	3.0	5.5	7.2	2.8	5.8	6.7
	10	8.6	10.0	20.6	7.8	10.4	18.7	7.0	10.8	16.8	6.0	11.0	14.4	5.6	11.6	13.4
	15	13.0	15.0	31.2	11.7	15.6	28.1	10.5	16.2	25.2	9.0	16.5	21.6	8.4	9.9	20.2
	20	17.2	20.0	41.3	15.2	20.8	36.5	14.0	21.6	33.6	12.0	22.0	28.8	11.2	23.2	26.9
42	3	2.9	3.0	7.0	2.5	3.2	6.0	2.2	3.2	5.3	2.0	3.4	4.8	1.8	3.4	4.3
	5	4.6	5.1	11.0	4.1	5.3	9.8	3.7	5.5	8.9	3.3	5.7	7.9	3.0	5.8	7.2
	10	9.2	10.2	22.1	8.2	10.6	19.7	7.4	11.0	17.8	6.6	13.7	15.8	6.0	11.6	14.4
	15	13.8	15.3	33.1	12.3	15.9	29.5	11.1	16.5	26.6	9.9	17.1	23.8	9.0	17.4	21.6
	20	18.4	20.4	44.2	16.4	21.2	39.4	14.8	22.0	35.5	13.2	27.4	31.7	12.0	23.2	28.8
44	3	3.1	3.1	7.4	2.8	3.3	6.7	2.4	3.4	5.8	2.1	3.5	5.0	1.9	3.5	4.6
	5	4.9	5.2	11.8	4.4	5.4	10.6	4.0	5.7	9.6	3.5	5.9	8.4	3.2	5.9	7.7
	10	9.8	10.4	23.5	8.8	10.8	21.1	8.0	11.4	19.2	7.0	11.8	16.8	6.4	11.8	15.4
	15	14.7	15.6	35.3	13.2	16.2	31.7	11.1	16.5	26.6	10.5	17.7	25.2	9.6	17.7	23.0
	20	19.6	20.8	47.0	17.6	21.6	42.2	16.0	22.8	38.4	14.0	23.6	33.6	12.8	23.6	30.7
45	3	3.2	3.1	7.6	2.9	3.3	6.8	2.5	3.5	6.0	2.1	3.6	5.0	2.0	3.6	4.7
	5	5.0	5.2	11.9	4.5	5.5	10.8	4.1	5.8	9.8	3.6	6.0	8.6	3.3	6.0	7.9
	10	9.9	10.4	23.8	9.0	10.9	21.6	8.2	11.5	19.7	7.3	11.9	17.5	6.6	12.0	15.8
	15	14.8	15.6	35.5	13.3	16.4	31.9	11.8	17.0	28.3	10.8	17.8	25.9	9.9	18.0	23.8
	20	19.9	20.8	47.8	18.0	21.8	43.2	11.9	20.1	28.6	14.4	23.8	34.6	13.2	24.0	31.7
46	3	3.2	3.1	7.7	2.9	3.3	7.0	2.6	3.5	6.2	2.2	3.6	5.3	2.0	3.6	4.8
	5	5.0	5.2	12.0	4.6	5.5	11.0	4.2	5.8	10.1	3.7	6.0	8.9	3.4	6.1	8.2
	10	10.0	10.4	24.0	9.2	11.0	22.1	8.4	11.6	20.2	7.4	12.0	17.8	6.8	12.2	16.3
	15	15.0	15.6	36.0	13.4	16.5	32.2	12.6	17.4	30.2	11.1	18.0	26.6	10.2	18.3	24.5
	20	20.0	20.8	48.0	18.4	22.0	44.2	16.8	23.2	40.3	14.8	24.0	35.5	13.6	24.4	32.6
48	3	3.4	3.2	8.2	3.0	3.4	7.2	2.7	3.5	6.5	2.4	3.7	5.8	2.2	3.7	5.3
	5	5.2	5.3	12.5	4.8	5.6	11.5	4.3	5.9	10.3	3.9	6.1	9.4	3.6	6.2	8.6
	10	10.4	10.6	25.0	9.6	11.2	23.0	8.6	11.8	20.6	7.8	12.2	18.7	7.2	12.4	17.3
	15	15.6	15.9	37.4	14.4	16.8	34.6	12.9	17.7	31.0	11.7	18.3	28.1	10.8	18.6	25.9
	20	20.8	21.7	49.9	19.2	22.4	46.1	17.2	23.6	41.3	15.6	37.6	37.4	21.6	37.2	51.8
50	3	3.5	3.2	8.4	3.2	3.4	7.7	2.8	3.6	6.7	2.5	3.7	6.0	2.3	3.8	5.5
	5	5.4	5.4	13.0	5.0	5.7	12.0	4.5	6.0	10.8	4.1	6.2	9.8	3.8	6.3	9.1
	10	10.8	10.8	25.9	10.0	11.4	24.0	9.0	12.0	21.6	8.2	12.4	19.7	7.6	12.6	18.2
	15	16.2	16.2	38.9	15.0	17.1	36.0	13.5	18.0	32.4	12.3	18.6	29.5	11.4	18.9	27.4
	20	21.6	21.6	51.8	20.0	22.8	48.0	18.0	24.0	43.2	16.4	24.8	39.4	15.2	25.2	36.5

LCWT: Leaving chilled water temperature, °F
TR: Tons of refrigeration cooling capacity

kW: Compressor power input
Cooler GPM: Flow rate in US GPM for cooler



Single Phase Air Cooled Ratings
Models USAC-25 through USAC-60
25 through 60 Tons

LCWT °F	Model USAC	Ambient Air Temperature °F														
		85			95			105			115			120		
		TR	kW	Cooler GPM	TR	kW	Cooler GPM	TR	kW	Cooler GPM	TR	kW	Cooler GPM	TR	kW	Cooler GPM
40	25	21.5	25.0	51.6	19.5	26.0	46.8	17.5	27.0	42.0	15.0	27.5	36.0	14.0	29.0	33.6
	30	25.8	30.0	61.9	23.4	31.2	56.2	21.0	32.4	50.4	18.0	33.0	43.2	17.0	35.0	40.8
	40	34.4	40.0	82.6	31.2	41.6	74.9	28.0	43.0	67.2	24.0	44.0	57.6	22.4	46.4	53.8
	50	13.0	50.0	31.2	39.0	52.0	93.6	35.0	54.0	84.0	30.0	55.0	72.0	28.0	58.0	67.2
	60	51.6	60.0	123.8	47.0	63.0	112.8	42.0	65.0	100.8	36.0	66.0	86.4	33.6	69.6	80.6
42	25	23.0	25.5	55.2	20.5	26.5	49.2	18.5	27.5	44.4	16.5	28.5	39.6	15.0	29.0	36.0
	30	28.0	31.0	67.2	25.0	32.0	60.0	22.0	33.0	52.8	20.0	34.0	48.0	18.0	35.0	43.2
	40	37.0	41.0	88.8	33.0	43.0	79.2	30.0	44.0	72.0	26.4	45.6	63.4	24.0	30.0	57.6
	50	46.0	51.0	110.4	41.0	53.0	98.4	37.0	55.0	88.8	33.0	57.0	79.2	30.0	58.0	72.0
	60	55.0	61.0	132.0	49.0	63.6	117.6	44.0	66.0	105.6	39.6	68.4	95.0	36.0	69.6	86.4
44	25	24.5	26.0	58.8	22.0	27.0	52.8	20.0	38.5	48.0	17.5	29.5	42.0	16.0	29.5	38.4
	30	29.4	31.2	70.6	26.4	32.4	63.4	24.0	34.2	57.6	21.0	35.4	50.4	19.2	35.4	46.1
	40	39.0	41.6	93.6	35.0	43.0	84.0	32.0	46.0	76.8	28.0	47.0	67.2	26.0	47.0	62.4
	50	49.0	52.0	117.6	44.0	54.0	105.6	40.0	57.0	96.0	35.0	59.0	84.0	32.0	59.0	76.8
	60	59.0	62.4	141.6	53.0	65.0	127.2	48.0	68.4	115.2	42.0	71.0	100.8	38.4	71.0	92.2
45	25	24.7	26.0	59.3	22.5	27.3	54.0	20.5	28.7	49.2	18.0	29.7	43.2	16.5	30.3	39.6
	30	29.7	31.2	71.3	27.2	32.7	65.3	24.5	34.6	58.8	21.5	35.7	51.6	19.6	36.2	47.0
	40	39.5	41.6	94.8	36.0	43.5	86.4	33.0	46.1	79.2	29.0	47.5	69.6	26.5	48.0	63.6
	50	49.5	52.0	118.8	45.0	54.5	108.0	41.0	57.5	98.4	36.0	59.5	86.4	33.0	60.0	79.2
	60	59.5	62.4	142.8	54.1	65.5	129.8	49.2	69.0	118.1	43.2	71.5	103.7	39.7	72.1	95.3
46	25	25.0	26.0	60.0	23.0	27.5	55.2	21.0	29.0	50.4	18.5	30.0	44.4	17.0	31.0	40.8
	30	30.0	31.2	72.0	28.0	33.0	67.2	25.0	35.0	60.0	22.0	36.0	52.8	20.0	37.0	48.0
	40	40.0	41.6	96.0	37.0	44.0	88.8	34.0	46.0	81.6	30.0	48.0	72.0	27.0	49.0	64.8
	50	50.0	52.0	120.0	46.0	55.0	110.4	42.0	58.0	100.8	37.0	60.0	88.8	34.0	61.0	81.6
	60	60.0	62.4	144.0	55.2	66.0	132.5	50.4	69.6	121.0	44.4	72.0	106.6	41.0	73.2	98.4
48	25	26.0	26.5	62.4	24.0	28.0	57.6	21.5	29.5	51.6	19.5	30.5	46.8	18.0	31.0	43.2
	30	31.0	32.0	74.4	29.0	34.0	69.6	26.0	35.4	62.4	23.4	36.6	56.2	21.6	37.0	51.8
	40	42.0	43.0	100.8	38.0	45.0	91.2	34.4	47.2	82.6	31.2	49.0	74.9	29.0	49.6	69.6
	50	52.0	53.0	124.8	48.0	56.0	115.2	43.0	59.0	103.2	39.0	61.0	93.6	36.0	62.0	86.4
	60	62.4	36.6	149.8	57.6	67.2	138.2	51.6	70.8	123.8	46.8	73.2	112.3	43.2	74.4	103.7
50	25	27.0	27.0	64.8	25.0	28.5	60.0	22.5	30.0	54.0	20.5	31.0	49.2	19.0	32.0	45.6
	30	32.4	32.4	77.8	30.0	34.0	72.0	27.0	36.0	64.8	25.0	37.0	60.0	23.0	38.0	55.2
	40	43.0	43.0	103.2	40.0	46.0	96.0	36.0	48.0	86.4	33.0	50.0	79.2	30.4	50.4	73.0
	50	54.0	54.0	129.6	50.0	57.0	120.0	45.0	60.0	108.0	41.0	62.0	98.4	38.0	63.0	91.2
	60	64.8	64.8	155.5	60.0	68.4	144.0	54.0	72.0	129.6	49.2	74.4	118.1	45.6	75.6	109.4

LCWT: Leaving chilled water temperature, °F
TR: Tons of refrigeration cooling capacity

kW: Compressor power input
Cooler GPM: Flow rate in US GPM for cooler



Single Phase Water Cooled Ratings
Models USWC-3 through USWC-60
3 through 60 tons

LCWT °F	Model USWC	Condenser Leaving Water Temperature, °F											
		85				95				100			
		TR	kW	Cooler GPM	Cond GPM	TR	kW	Cooler GPM	Cond GPM	TR	kW	Cooler GPM	Cond GPM
40	3	3.0	3.0	7.2	9.0	2.8	3.0	6.7	8.4	2.6	3.0	6.2	7.8
	5	5.0	5.0	12.0	15.0	4.7	5.0	11.3	14.1	4.3	5.0	10.3	12.9
	10	10.0	10.0	24.0	30.0	9.3	10.0	22.3	27.9	8.6	10.0	20.6	25.8
	15	15.0	15.0	36.0	45.0	14.0	15.0	33.6	42.0	13.0	15.0	31.2	39.0
	20	20.0	20.0	48.0	60.0	18.6	20.0	44.6	55.8	17.2	20.0	41.3	51.6
	25	25.0	25.0	60.0	75.0	23.3	25.0	55.9	69.9	21.5	25.0	51.6	64.5
	30	30.0	30.0	72.0	90.0	27.9	30.0	67.0	83.7	25.8	30.0	61.9	77.4
	40	40.0	40.0	96.0	120.0	37.2	40.0	89.3	111.6	34.4	40.0	82.6	103.2
	50	50.0	50.0	120.0	150.0	46.5	50.0	111.6	139.5	43.0	50.0	103.2	129.0
60	60.0	60.0	144.0	180.0	55.8	60.0	133.9	167.4	51.6	60.0	123.8	154.8	
44	3	3.5	3.1	8.4	10.5	3.3	3.1	7.9	9.9	3.1	3.1	7.4	9.3
	5	5.4	5.2	13.0	16.2	5.2	5.2	12.5	15.6	4.9	5.2	11.8	14.7
	10	10.8	10.4	25.9	32.4	10.3	10.4	24.7	30.9	9.8	10.4	23.5	29.4
	15	16.2	15.6	38.9	48.6	15.5	15.6	37.2	46.5	14.7	15.6	35.3	44.1
	20	21.5	20.8	51.6	64.5	20.6	20.8	49.4	61.8	19.6	20.8	47.0	58.8
	25	27.0	26.0	64.8	81.0	25.8	26.0	61.9	77.4	24.5	26.0	58.8	73.5
	30	32.5	31.2	78.0	97.5	31.0	31.2	74.4	93.0	29.4	31.2	70.6	88.2
	40	43.2	41.6	103.7	129.6	41.1	41.6	98.6	123.3	39.0	41.6	93.6	117.0
	50	54.0	52.0	129.6	162.0	51.5	52.0	123.6	154.5	49.0	52.0	117.6	147.0
60	64.5	62.4	154.8	193.5	61.8	62.4	148.3	185.4	59.0	62.4	141.6	177.0	
48	3	4.0	3.2	9.6	12.0	3.7	3.2	8.9	11.1	3.4	3.2	8.2	10.2
	5	5.8	5.3	13.9	17.4	5.5	5.3	13.2	16.5	5.2	5.3	12.5	15.6
	10	11.6	10.6	27.8	34.8	13.8	10.6	33.1	41.4	10.4	10.6	25.0	31.2
	15	17.4	15.9	41.8	52.2	16.5	15.9	39.6	49.5	15.6	15.9	37.4	46.8
	20	23.0	21.7	55.2	69.0	21.9	21.7	52.6	65.7	20.8	21.7	49.9	62.4
	25	29.0	26.5	69.6	87.0	27.5	26.5	66.0	82.5	26.0	26.5	62.4	78.0
	30	35.0	32.0	84.0	105.0	33.0	32.0	79.2	99.0	31.0	32.0	74.4	93.0
	40	46.4	43.0	111.4	139.2	44.2	43.0	106.1	132.6	42.0	43.0	100.8	126.0
	50	58.0	53.0	139.2	174.0	55.0	53.0	132.0	165.0	52.0	53.0	124.8	156.0
60	69.0	63.6	165.6	207.0	65.7	63.6	157.7	197.1	62.4	63.6	149.8	187.2	

LCWT: Leaving chilled water temperature, °F
TR: Tons of refrigeration cooling capacity

kW: Compressor power input
Cooler GPM: Flow rate in US GPM for cooler
Cond GPM: Flow rate in US



USAC Physical Data

USAC-3, 4, 5, 8

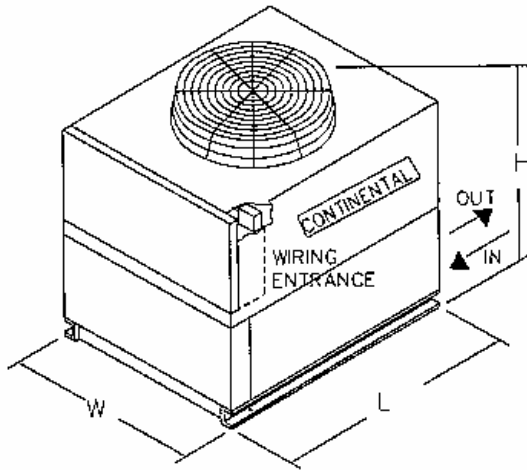

USAC-10, 12, 15, 20

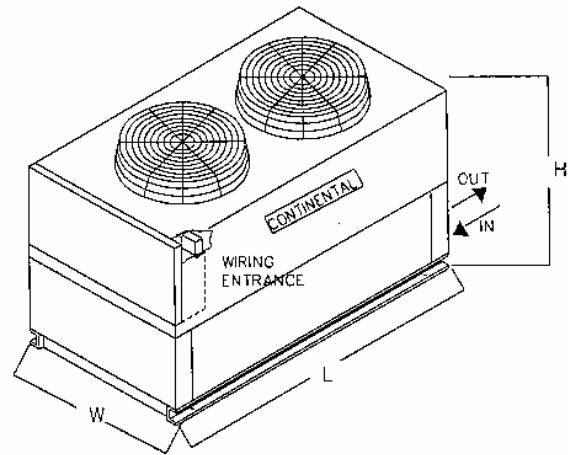

USAC-25, 30

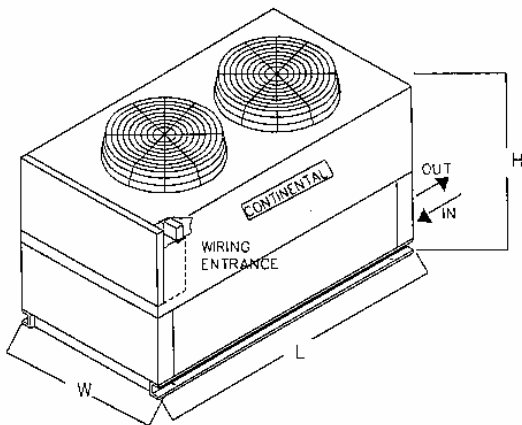

USAC-40, 50, 60

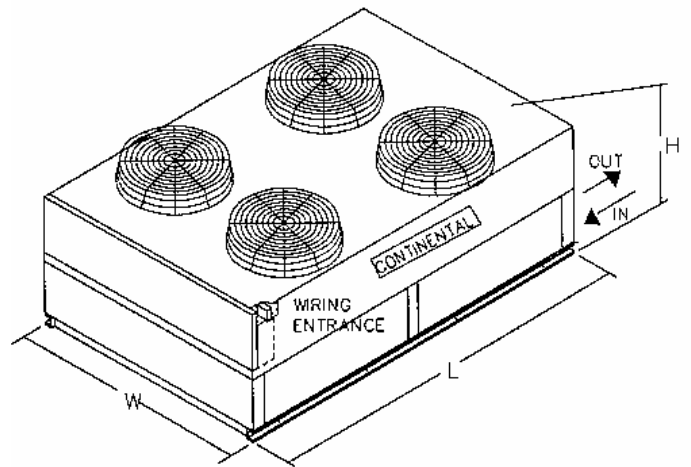

Model USAC	Dimensions			Weight, lbs.	Water Connections		Est R-22 Charge, lbs.
	L"	W"	H"		Inlet, MPT"	Outlet, MPT"	
-3, 4	48	43	53	500/600	3/4	3/4	9/11
-5, 8	48	43	53	650/900	1	1	12/18
-10, 12, 15, 20	90	43	55	1,100/1,300/1,500	2	2	22/25/30/40
-25, 30	120	43	55	2,000/2,300	3	3	50/60
-40	90	86	55	3,000	4	4	85
-50, 60	120	86	55	4,000/4,500	4	4	110/140



USWC Physical Data

USWC-3, 5, 10

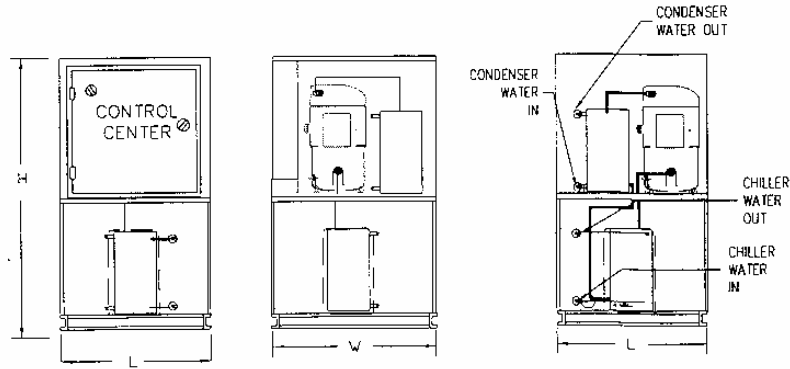

USWC-15, 20

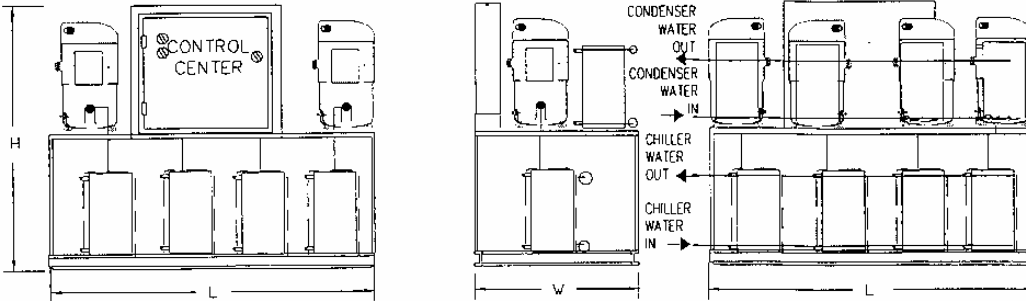

USWC-25, 30

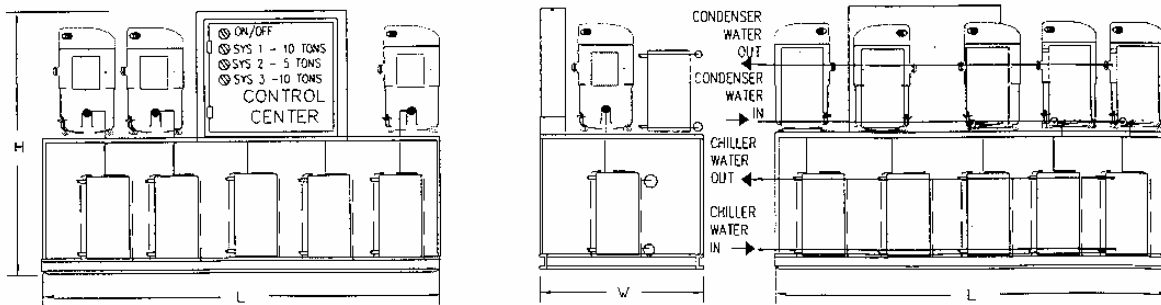

Model USWC	Dimensions			Weight, lbs.	Water Connections, Inlet"/Outlet"		Est R-22 Charge, lbs.
	L"	W"	H"		Condenser	Cooler	
-3, 5	20	34	48	400/500	3/4	3/4	7/14
-10	20	34	48	700	1	1	24
-15, 20	48	34	48	900/1,000	1 1/2	1 1/2	40/55
-25, 30	84	34	48	1,200/1,600	2	2	65/80

For models larger than USWC-30, please contact the factory for data



Electrical Data USAC Packaged Air Cooled Chillers																	
Model	Total Unit			Compressor Motor Data					Condenser Fan Motor Data								
	MCA	Max Fuse	Rec. Fuse	Qty	HP Each	RLA Each	LRA Each	MCC Each	Standard Unit			Optional Low Ambient Unit					
									Qty	HP Each	FLA Each	Single Phase/Single Speed Motor			Single Phase/Speed Control		
												Qty	HP Each	RLA Each	Qty	HP Each	RLA Each
USAC-3	30	45	35	1	3	18.4	95	25.8	1	0.75	5.3	-	-	-	1	0.75	5.3
USAC-4	33	55	40	1	4	22.1	137	31	1	0.75	5.3	-	-	-	1	0.75	5.3
USAC-5	45	77	55	1	5	32.1	148	45	1	0.75	5.3	-	-	-	1	0.75	5.3
USAC-8	55	77	60	2	4	22.1	137	31	1	0.75	5.3	-	-	-	1	0.75	5.3
USAC-10	83	115	90	2	5	32.1	148	45	2	0.75	5.3	1	0.75	5.3	1	0.75	5.3
USAC-12	83	105	88	3	4	22.1	137	31	2	0.75	5.3	1	0.75	5.6	1	0.75	5.3
USAC-15	115	150	125	3	5	32.1	148	45	2	0.75	5.3	1	0.75	5.3	1	0.75	5.3
USAC-20	150	180	160	4	5	32.1	148	45	2	0.75	5.3	1	0.75	5.3	1	0.75	5.3
USAC-25	185	215	200	5	5	32.1	148	45	2	1.5	6.6	1	1.5	6.6	1	1.5	6.6
USAC-30	220	250	230	6	5	32.1	148	45	2	1.5	6.6	1	1.5	6.6	1	1.5	6.6
USAC-40	290	325	300	8	5	32.1	148	45	4	0.75	5.3	2	0.75	5.3	2	0.75	5.3
USAC-50	350	390	370	10	5	32.1	148	45	4	1.5	6.6	2	1.5	6.6	2	1.5	6.6
USAC-60	420	450	430	12	5	32.1	148	45	4	1.5	6.6	2	1.5	6.6	2	1.5	6.6

Electrical Data USWC Packaged Water Cooled Chillers								
Model	Total Unit			Compressor Motor Data				
	MCA	Max Fuse	Rec. Fuse	Qty	HP Each	RLA Each	LRA Each	MCC Each
USWC-3	25	40	30	1	3	18.4	95	25.8
USWC-4	28	50	35	1	4	22.1	137	31
USWC-5	40	72	50	1	5	32.1	148	45
USWC-8	50	72	55	2	4	22.1	137	31
USWC-10	72	104	80	2	5	32.1	148	45
USWC-12	72	95	77	3	4	22.1	137	31
USWC-15	104	106	115	3	5	32.1	148	45
USWC-20	136	169	145	4	5	32.1	148	45
USWC-25	169	200	175	5	5	32.1	148	45
USWC-30	200	233	200	6	5	32.1	148	45
USWC-40	265	297	275	8	5	32.1	148	45
USWC-50	330	360	360	10	5	32.1	148	45
USWC-60	395	425	400	12	5	32.1	148	45

Notes:

1. All units have across-the-line start.
2. RLA (rated load amps) rated in accordance with ARI Standard.
3. MCA (minimum circuit amps) equal 125% of the RLA for the largest motor in the circuit plus 100% of the RLA for all other motors in the circuit per N.E.C.
4. Based on copper conductors with 75° C insulation per N.E.C. Table 310-16.
5. Max fuse size is based on 225% of the RLA for the largest motor in the circuit plus 100% of the RLA for all other motors in the circuit per N.E.C. This is the largest fuse allowed per N.E.C. A smaller fuse is often recommended based on the unit application and ambient temperature.



Installation and Application Data

General

Continental UniPac™ Air Cooled Packaged Chillers models USAC are designed for *outdoor* installations and normal exposure to summer and winter conditions. The vertical condenser air discharge feature allows rooftop or ground installations. Horizontal units are also available.

The enclosure door is provided to protect the electrical components against unauthorized access. However, consideration should be given to a field-installed protective fence to further reduce possibility of accidental damage or unauthorized entry, especially for ground level installations. Field installed fence must have a minimum of 50% open area.

Continental UniPac™ Water Cooled Packaged Chillers models USWC are designed for *indoor* installations and normal indoor conditions.

However, if outdoor installation is required, the factory option of a complete unit enclosure and heater tape with thermostat for the cooler and condenser must be ordered.

The following guidelines are recommended:

Location for Air Cooled Systems

1. Whether it is a rooftop or ground level installation, select a place with unrestricted fresh air supply for the air cooled condenser and minimum sun exposure.
2. Avoid locations between structures, beneath windows, or any other restriction that may affect adequate air supply to the condenser and where normal operating sounds may be objectionable.
3. The condenser fans are propeller type and are not designed for use with duct work

Location for Water Cooled Systems

1. The preferred location for the water cooled system is a proper plant room with at least 4ft access on all four sides.

Foundation

All chillers should be mounted on a flat and level foundation, ground, or rooftop, capable of supporting the total operating weight of the unit and service personnel.

(a) **Ground Level** It is important that the units be installed on a substantial base that will not settle, causing strain on the liquid lines, resulting in possible leaks. Mounting holes (9/16") are provided in the unit steel channels for bolting the unit to its foundation. An independent one-piece concrete slab, not tied to the main building and with footers extended below the frost line, is recommended.

(b) **Roof-top** Rooftop installations will require consideration by an architect and contractor to have adequate structural strength to safely support the entire operating weight of the unit and service personnel. Structurally transmitted vibration and sound must be avoided by mounting the unit on proper isolators.

Clearances

1. Air cooled systems draw air from all sides; therefore units must be installed with sufficient clearances for air entrance to the condenser coil, for air discharge away from the condenser, and for servicing. Minimum clearances for all units are 4 feet on all sides.
2. In installations where winter operation is intended and snow accumulations are expected, additional height must be provided in order to insure normal condenser airflow.
3. When free airflow to the condenser is reduced or restricted, condenser air may be recirculated, considerably reducing system capacity and increasing power consumption. All ratings are based on free air discharge.

4. For multiple units, a minimum lateral clearance of 10 feet between two units is recommended.

Field Piping

1. If a circulating pump is field furnished, the pump must *discharge into the cooler first and then through the cooler to the system.*
2. Provide stop valves on all inlet and outlet piping to facilitate servicing.
3. Provide drain connections at low points to permit drainage of cooler and field piping.
4. Provide air vents at high points easily accessible for servicing
5. Provide a strainer on the inlet to the cooler.
6. Provide wall hangers and rubber isolated piping hangers to reduce sound and vibration transmission through liquid piping.
7. Provide thermometers and pressure gauges for installation in the inlet and outlet water lines. These items are available as optional features and are not included in the standard unit.
8. Chilled water lines should be insulated to reduce heat pick up and prevent condensation.
9. For winter low ambient operation, it is recommended that a heater cable of 4 watts per lineal foot of pipe be installed, and exposed lines be properly insulated to protect against freeze conditions.
10. Flush all chilled water piping prior to final connection to the UniPac™ chiller systems.

Water Treatment

Adequate water treatment should be determined locally, depending on the local water quality and the type of system. Any foreign material or dirt in the water system can adversely affect the performance of the UniPac™ unit.

Freeze Protection

Continental recommends use of a premixed glycol (Propylene or Ethylene) or HVAC heat transfer fluids. Contact factory for more details. *Automotive antifreeze is not recommended because these often include silicates. Silicates end up coating the heat transfer surface reducing efficiency, fouling the system and shortening the life of the pump seals.*

Corrosive Atmosphere Operation

Continental offers the following choices of condenser coil combinations for various corrosive atmospheres.

Blygold or Heresite coating for aluminum fins; Copper Fins with Blygold or Heresite coating or complete unit coated with Blygold, Imron or Heresite.

Field Electric Wiring

All field wiring must be in accordance with applicable local/national codes and ordinances

Continental chiller systems are factory wired for optimum reliability. Controls are factory set for the operating conditions. These controls *must not be field modified without written consent from Continental*; otherwise the warranty is voided. The use of a simple remote switch or timer is permitted but it must be connected to the Continental control panel at points specifically indicated for that purpose.

Remote chilled water set point option is available- see under options.



UniPac™ Guide Spec

Furnish and install where indicated on plans Qty _____
Continental UniPac™ model (USAC, USWC) _____
packaged liquid chiller(s).

The (each) unit shall have a cooling capacity of _____ Tons with _____ compressor kW when cooling _____ GPM of water from _____ °F to _____ °F and a cooler fouling factor of 0.00025 Hr. Sq. Ft °F/Btu. The water pressure drop shall not exceed _____ feet of water through the cooler. The USAC entering air temperature will be _____ °F. The USWC unit will be supplied with _____ GPM of _____ °F condenser water with a condenser fouling factor of 0.00025 Hr. Sq. Ft. °F/Btu. The condenser water pressure drop shall not exceed _____ ft of water.

The unit overall dimensions shall not exceed _____ ins. In length. _____ ins in width and _____ ins. In height. The unit operating weight shall not exceed _____ lbs.

General

Packaged Liquid Chiller shall be completely factory assembled including all interconnecting refrigerant piping and internal wiring controls, mounted on a steel frame which accommodates the air (water) cooled condenser, compressor and cooler. The units shall be leak tested, evacuated and shipped with a vapor charge of R-22.

Split chillers shall be field piped, pressure tested, evacuated and then field charged with R-22.

All units shall include the following:

Compressor Motor

USAC/USWC compressor motor shall be state-of-the-art scroll with fewer moving parts and sweated without valves. All compressor(s) shall be mounted on resilient pads to minimize vibration. Safety internal relief per ASA-B9.1 Code.

Cooler

The cooler shall be direct expansion shell and coil type with refrigerant in the shell and liquid to be chilled in the tube. The design working pressure of the cooler shell (liquid) side shall be 150 psig. And 200 psig for the tube (refrigerant) side. The cooler shall be insulated with ¾" closed cell insulation.

Condenser-Air Cooled

The condenser shall be of copper tube, aluminum fin construction. Fans shall be propeller-type direct driven by totally enclosed "air over" motors with built-in overload protection, positioned within the cabinets for weather protection.

Condenser – Water Cooled

The condenser shall be shell and coil type with water flowing through seamless copper tubes and refrigerant through the carbon steel shell

Refrigerant Circuit

Each refrigerant circuit shall be constructed of copper tubing with brazed joints, and shall include: filter drier, solenoid valve, sight glass, thermal expansion valve, with external equalizer. The entire suction line shall be insulated.

Control Center

The control center shall be NEMA-1 type for indoor models and weatherproof for outdoor models.

All power starting and safety/operating controls shall be mounted in a fully enclosed control panel with access door

Power controls shall include:

- Single point electrical terminal block
- Compressor-motor contactor(s)
- Compressor run capacitor(s)
- Fan motor contactor(s) (air cooled units only)
- Control circuit fuse
- Control circuit terminal block

Safety/Operating controls shall include:

- Two position switch indicating *off/system on* – per circuit
- High Pressure control with manual reset –per circuit
- Low pressure control with auto reset – per circuit
- Adjustable chilled water temperature controller
- Adjustable freeze stat
- Adjustable compressor anti-recycle timer(s)
- Relay(s)
- Built-in compressor-motor overload

Available Factory Supplied Accessories

Control Transformer Factory mounted transformer converts unit power to control voltage for single point electrical (115, 240 or 24 volt).

Flow Switch Factory mounted and wired to the control panel.

Chilled Water Pump Package Factory mounted and wired chilled water pump with starter in the control panel and interlocked with flow switch.

MicroProcessor Controls State-of-the-art microprocessor.

Operating Gauges Suction and discharge gauges factory installed and piped to each compressor.

Indicating Lights are wired and mounted on control panel. Lights furnished for Power On, High Pressure and No Flow/Freeze.

Vibration Isolators Level adjusting spring type 1" deflection or Neoprene pads, shipped loose.

Low Ambient Accessory (Air Cooled Models Only) Standard unit will operate down to 45°F. Unit will operate down to 0°F with this factory-mounted accessory of fan speed control, or add low ambient to -20°F.

Non-Fused Disconnect Switch Factory mounted and wired to control panel. NEMA 3R for air cooled, NEMA 1 for water cooled.

Blygold Coated Condenser Copper tube/aluminum fin or copper tube/copper fin coated with Blygold.

Heresite Coated Condenser phenolic corrosion resistant coating for copper tube and aluminum fin coil or copper/copper coil.

Copper Fin Condenser Coil Copper fin condenser coils.

Sound Attenuator consists of sound absorbing material that surrounds compressor. Factory installed.

Dual Unit Kit allows operation of two or more units with parallel or series water circuit. Field mounted.

Alarm Bell Contacts allows alarm bell connection to pressure controls for signaling if unit fails on manual reset controls.

Water Flange Kit Factory or field mounted consists of 150 lb raised flanges to convert to flanged cooler connections.

High Return Water Thermostat Factory mounted thermostat senses high return water temperature at start-up. Allows unit to run un-loaded instead of shutting down due to high head pressure.

Desuperheaters Provides "free hot water" by recovering heat from superheated gas.

Compressor Cycle Counter/Hour Meters Cycle counter and hour meter.

Remote Display Panel allows operator to monitor and control chiller operation from a remote location.