

ATD TOOLS, INC.

PRODUCT SPECIFICATIONS

MODEL #:	RHO-10107
DESCRIPTION:	BOTTLE JACK
CAPACITY:	20 TON
JACK SIZE:	6 1/4" (L) X 5 7/8" (W)
SADDLE MIN. HEIGHT:	9 1/2"
SADDLE MAX. HEIGHT:	18 5/8"
SCREW EXT.:	3 1/8"
HANDLE LENGTH:	18 1/8"
OPERATING FORCE:	101 LBS
SADDLE DIA.:	2"
VOLUME OF HYD. OIL:	498 C.C.
NET WEIGHT:	27.5 LBS
GROSS WEIGHT:	59 LBS/ 2 PCs
COLOR BOX DIM.:	6 3/4" (L) X 6 3/8" (W) X 10 3/8" (H)
CARTON BOX DIM.:	13 1/4" (L) X 7" (W) X 10 7/8" (H)
CUFT.:	0.58 CUFT (1300 PCs/ 20' CTN)

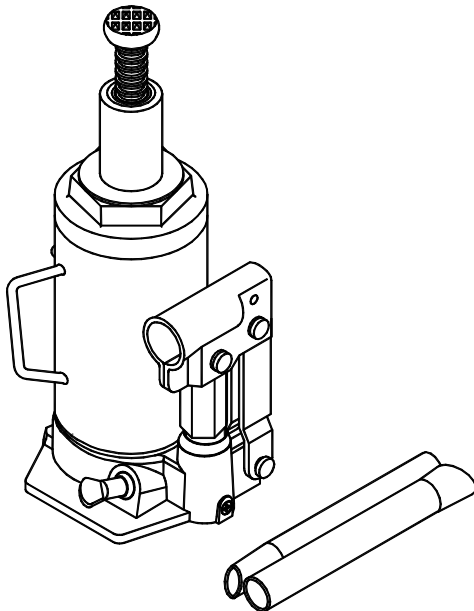

FEATURE

- MEETS ASME/ANSI - PALD SAFETY STANDARDS
- LIFTING RANGE: 9 1/2" TO 18 5/8"
- PATENTED BUILT-IN BY-PASS DEVICE MECHANISM
- TWO PIECE HANDLE
- HEAT TREATED EXTENSION SCREW