

FREEZERS

CT-100F



Key Features

- Counter Top Freezer
- Top Mounted Forced Air Refrigeration
- Illuminated Header
- Bright Interior Lighting
- Adjustable Thermostat
- -11°F to 28°F Temperature Range
- Self Closing Door
- Brushed Aluminum Door Frame
- Adjustable Wire Shelves

Model	Doors	Capacity cu.ft (lt)	Shelves	Exterior Dimensions inches (mm)			Interior Dimensions inches (mm)			Power (V-Hz-Ph)	Amps	HP	Crated Weight lbs (kg)
				L	D	H	L	D	H				
CT-100F	1	2 1/2 (72)	2	20 7/8 (530)	18 7/8 (480)	33 1/8 (840)	16 1/8 (409)	13 3/4 (350)	20 1/8 (510)	115.60.1	3	1/5	99 (45)

Details

Cabinet Construction

- Exterior: Galvanized, pre-painted steel cabinet, gray.
- Interior: Durable aluminum lining allows for easy cleaning.
- High-density, CFC-Free, polyurethane insulation.
- Illuminated header panel for attractive branding.
- Four (4) low profile adjustable feet. 4 inch legs are also included.

Door

- Self-closing door with brushed aluminum frame and recessed side handle.
- Low-E, tempered, thermal glass door for increased efficiency and maximum product visibility.
- Strong magnetic gasket ensures a tight seal.

Shelving

- Two (2) heavy-duty galvanized wire shelves: 16" x 12 3/4" (406 x 324) with stainless steel shelf brackets.
- Easily adjustable in 1/2" increments.

Lighting

- Bright fluorescent lighting provides for maximum illumination of products.
- Utilizes T8 bulbs and an electronic ballast for increased energy efficiency and extended life.

Electrical

- Ready for connection to 115V/60Hz single phase 20 amp outlet.
- Includes an 8' cord and plug set.



NEMA 5-15R

Refrigeration System

- Forced air, environmentally friendly refrigeration system using CFC-free R404A refrigerant.
- Self-contained heated drain pan and condensate evaporation system.
- Automatic self-defrost cycle.
- Electronic temperature control maintains -11°F to 28°F (-24°C to -2°C).
- Top mounted refrigeration unit allows for easy maintenance and service.

Options

- 208-230V/ 50Hz
- Custom Graphics
- Additional Shelves
- Various Cabinet Colors

Technical Drawing

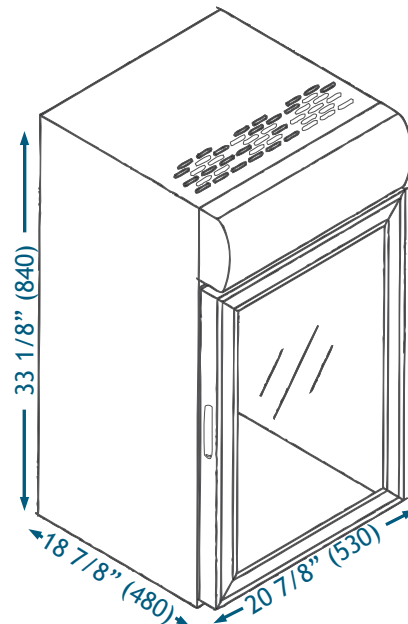

CT-100F



3235 Industry Drive • Suite C
North Charleston, SC 29418
Phone: 843-767-6855
Toll Free: 800-905-4768

Fax: 843-767-6858
Toll Free Fax: 800-906-4768
www.atcgroup.net
sales@atcgroup.net

WARRANTY

One year warranty on all parts and labor and an additional 4 year prorated warranty on compressor.