

MATSUSHITA Compressor

MODEL# DA66C10RCU6

Single Phase
R-134a

115 V
60 Hz

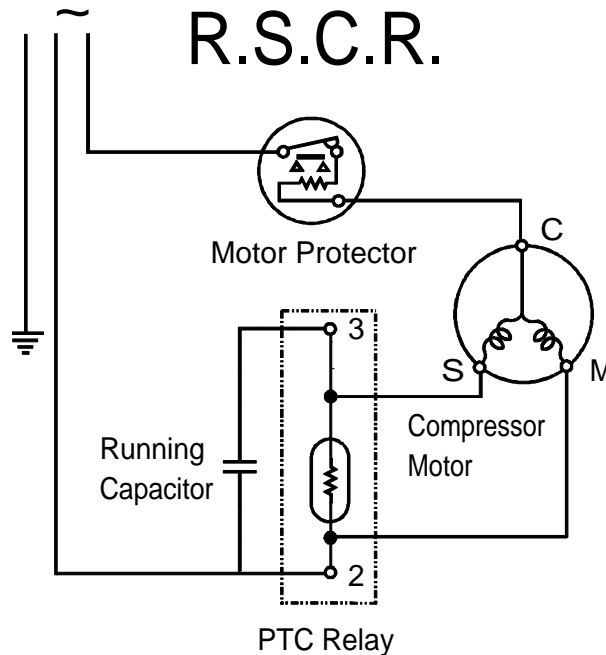
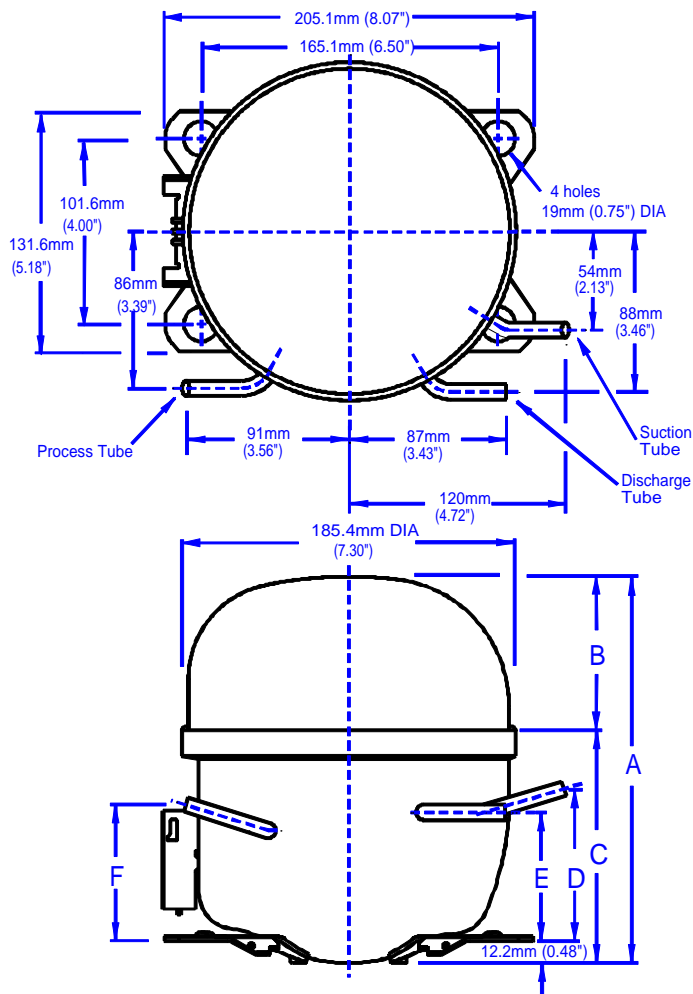

Dimensions*

	mm	inches
A	211.8	8.34
B	84.2	3.31
C	127.6	5.02
D	83.9	3.30
E	70.4	2.77
F	75.2	2.96

* All dimensions are for reference only

This document sets forth certain operational parameters and conditions for operation of this product. If this product is operated outside of the parameters and conditions stated herein, buyer assumes sole and full responsibility and shall indemnify seller with respect to all product failures and all consequences thereof. Operation of the product outside of the parameters and conditions specified herein shall serve to invalidate all seller warranties, if any, with respect to the product. This document is for reference only. For specifications, please contact Panasonic's engineering department.

Tubes	Tube O.D.	Wall	Material
Suction	0.33 in. / 8.3 mm	0.035 in. / 0.9 mm	Copper
Process	0.33 in. / 8.3 mm	0.035 in. / 0.9 mm	Copper
Discharge	0.33 in. / 8.3 mm	0.035 in. / 0.9 mm	Copper

U.L. File # SA 4615
C.S.A. File #'s LR - 36593

General Data

- Oil Charge 250 cc ± 5 cc / 15.3 cu.in. ± 0.3 cu.in.
- Net Weight With Oil 22.0 lbs, 10.0 kg
- Approved Oils:
 - FREOL α 10, α 10E, α 15, α 15E, α 22, α 22E
 - ICI RL10H, RL15H, RL22H
 - HENKEL ProEco 10S, 15S, 22S
- Residual Moisture 120 mg max.
- Impurities 10 mg max.
- Displacement 6.55 cc. / 0.400 cu. in.

Panasonic®

Panasonic Industrial Company
Refrigeration Products Department
Tel: 201 - 392 - 4249
Fax: 201 - 392 - 4315

Rev#1-5/9