



Installation, Start-Up and Service Instructions

Hermetic, Water-Cooled

CONTENTS

	Page
SAFETY CONSIDERATIONS	1
BEFORE INSTALLATION	1
Check Shipment	1
Unit Location Considerations	1
INSTALLATION	1-8
Mount Unit	1
Piping Connections	1
Electrical Connections	4
Limitations	6
Refrigerant Charging	8
INITIAL START-UP	8
To Start Compressor	8
CHECKING OPERATION	8,9
Oil Charge	8
High-Pressure Switch	8
Low-Pressure Switch	8
Oil Pressure Switch	8
Time Guard® Control	8
CAPACITY CONTROL	9,10
Control Set Point	9
To Regulate Control Set Point	9
Pressure Differential Adjustment	9
Capacity Control Pressure	10
CONDENSER MAINTENANCE	10,11
SERVICE	12-17
Service Notes	12
Testing Oil Pump	12
Cylinder Heads	14
Service Replacement Compressors	14
Suction and Discharge Valve Plate Assembly	15
Cleaning Suction Strainer	16
Motor Replacement	16
Terminal Plate Assembly	16
Compressor Running Gear Removal	16
Compressor Running Gear Replacement	17
COMPRESSOR MOTOR BURNOUT	17
Clean-Up Procedure	17
TROUBLESHOOTING	18,19

SAFETY CONSIDERATIONS

Installing, starting up and servicing this equipment can be hazardous due to system pressures, electrical components and equipment location (roofs, elevated structures, etc.). Only trained, qualified installers and service mechanics should install, start up and service this equipment.

When working on the equipment, observe precautions in the literature, tags, stickers and labels attached to the equipment and any other safety precautions that apply. Follow all safety codes. Wear safety glasses and work gloves. Use care in handling, rigging and setting bulky equipment.

▲ WARNING

Electrical shock can cause personal injury and even death. Be sure power to equipment is shut off before installing or servicing this equipment. There may be more than one disconnect. Tag disconnect(s) to alert others not to turn power on until work is completed.

BEFORE INSTALLATION

Check Shipment — File claim with shipping company if shipment is damaged or incomplete.

Unit Location Considerations — Locate unit on floor in a well-ventilated area. Position unit to allow sufficient space for refrigerant and water connections and to service compressor. Place unit so suction and discharge valves can be easily reached and oil level checked. Do not install condensing unit where temperature will fall below freezing.

Local water can cause excessive fouling or sealing of condenser tubes. If such conditions are anticipated, a water treatment analysis is recommended. Refer to Carrier System Design Manual, Part 5, for general water conditioning information.

Make provision in piping layout to drain and vent condenser if system is to be shut down in winter.

INSTALLATION

Mount Unit — Level unit and bolt firmly to foundation. Loosen compressor mounting bolts and remove shipping blocks from under compressor. Tighten all 4 bolts on compressor. Next, loosen each bolt until the flanged washer can be moved sideways with finger pressure.

NOTE: Be sure that compressor floats freely on mounting springs.

Piping Connections — Attach water supply and return lines to connections indicated on condenser unit (Fig. 1). Water leaving condenser should not be connected directly into sewer lines. Check local codes.

Attach refrigerant liquid and suction lines to condensing units (Fig. 1); suction and discharge to compressor unit (Fig. 2). When soldering or brazing piping to valves, disassemble valve or wrap it in a wet cloth to prevent heat damage. Allow flexibility in suction line so compressor suction valve may be moved aside for access to suction strainer.

DIMENSIONS (in.)

UNIT 07D	WIDTH A
A203	30
B205	30
A208	39 ⁹ / ₁₆
B210	51 ⁹ / ₁₆
B212	51 ⁹ / ₁₆
B215	63 ¹³ / ₁₆

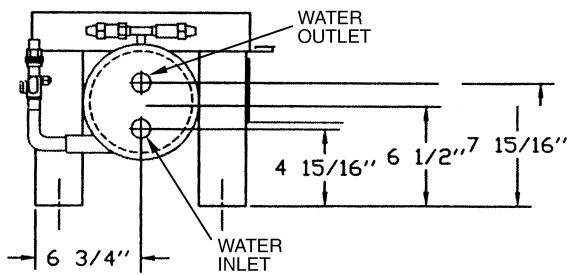
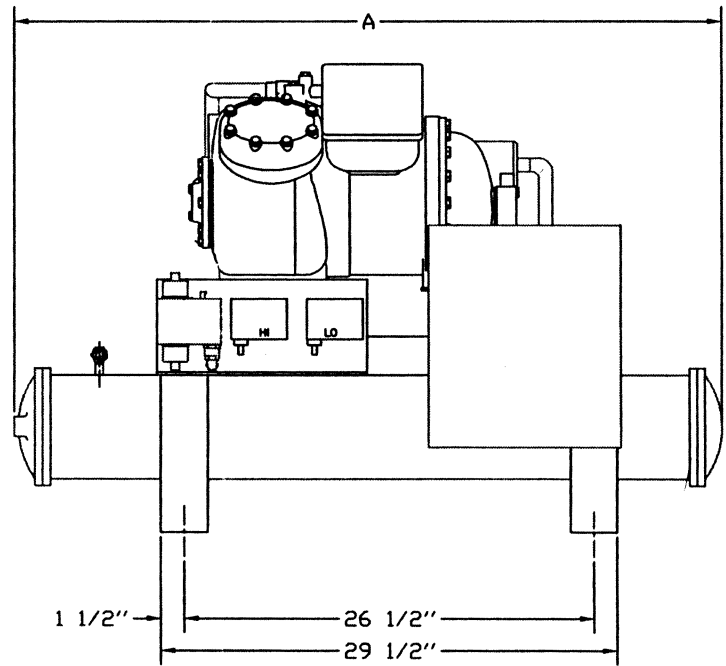
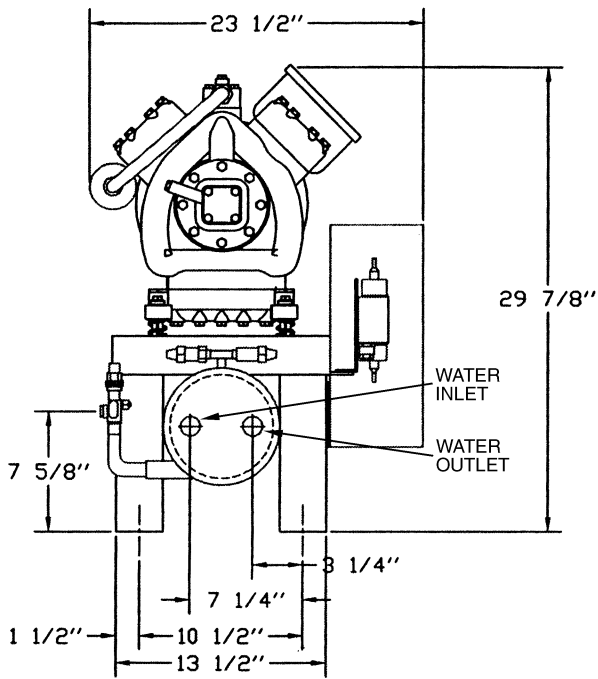
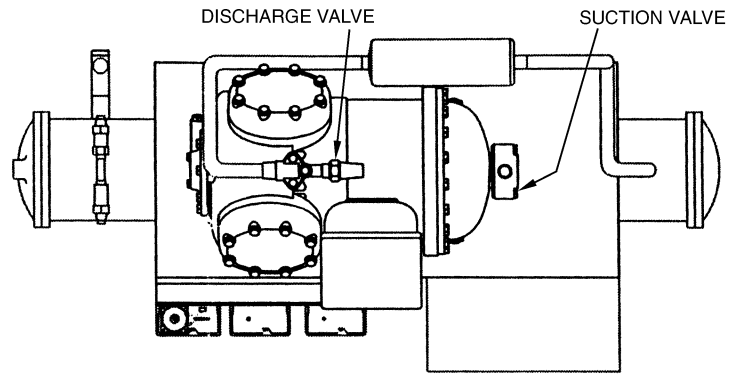

WATER CONNECTIONS FOR 07DB215 UNIT ONLY.

NOTES:

1. For standard service practices, such as troubleshooting and refrigerant charging, allow a minimum 2'-6" clearance around the unit.
2. Recommended service space for condenser tube removal is one condenser length at either end.
3. For compressor removal, allow a minimum 3' wide access aisle to and from the unit.
4. Local codes or jurisdiction may prevail for unit clearances.

Fig. 1 — 07D Condensing Unit Dimensions

NOTES:

1. For standard service practices, such as troubleshooting and refrigerant charging, allow a minimum 2'-6" clearance around the unit.
2. For compressor removal, allow a minimum 3' wide access aisle to and from the unit.
3. Local codes or jurisdiction may prevail for unit clearances.

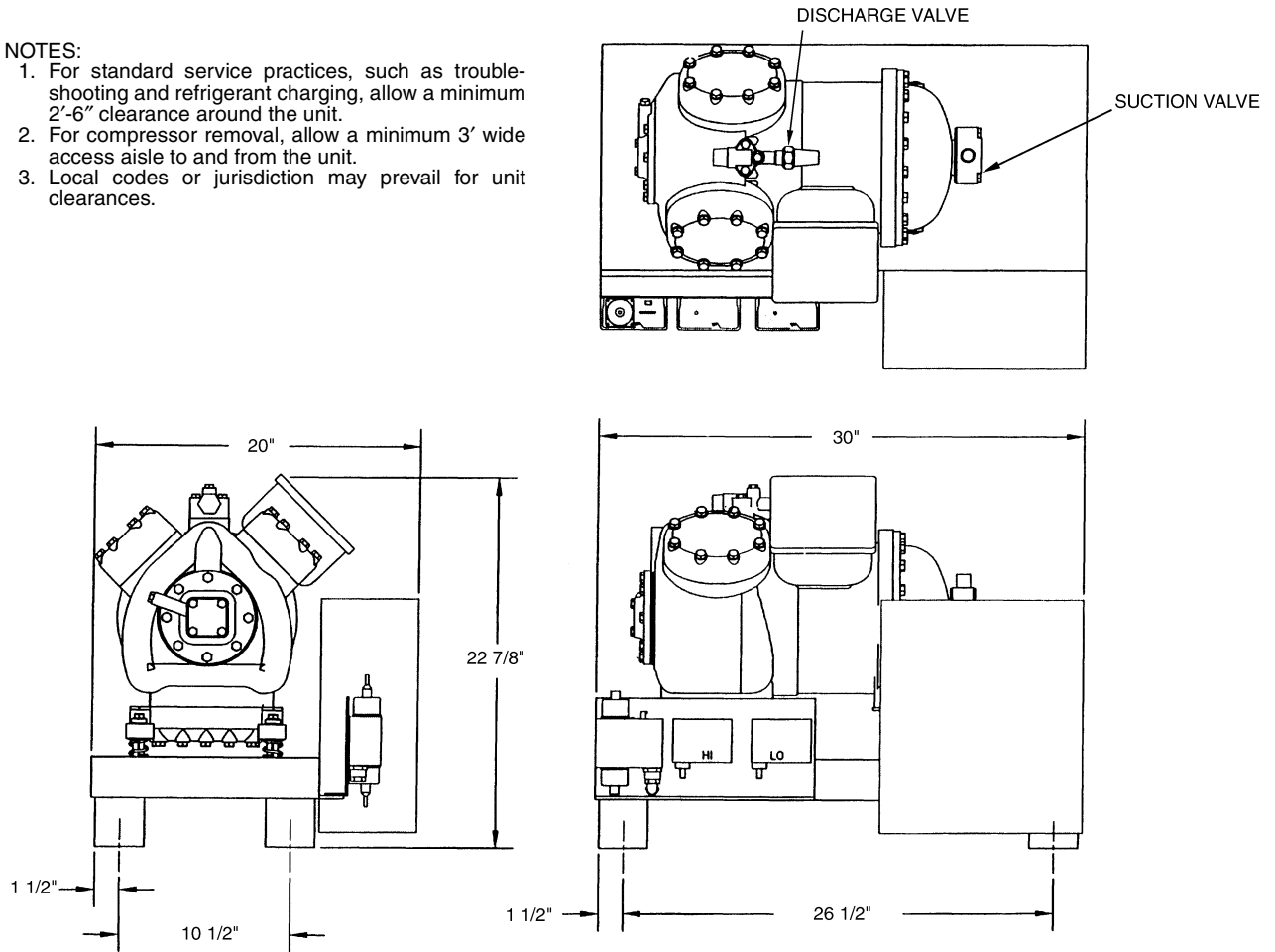

Fig. 2 — 06D Compressor Unit Dimensions

Install a solenoid valve (field supplied) in liquid line directly before expansion valve. Solenoid valve is necessary for single pumpout control used on 06D, 07D units. Refrigerant filter drier and moisture indicator are shipped with 07D condensing units for field installation. Install in liquid line according to manufacturer's instructions.

Relief valve located on top of condenser (07D units) will open to relieve excessive pressure, allowing refrigerant to escape. Most local codes require piping from safety device to outdoors.

Refer to Carrier System Design Manual, Part 3, for standard piping techniques.

COMPRESSOR UNITS — Connect high- and low-pressure switch capillary tubes from control box to compressor. See Fig. 2.

Install discharge line muffler (accessory) in discharge line as close to compressor shutoff valve as possible.

Electrical Connections

UNBALANCED 3-PHASE SUPPLY VOLTAGE — *Never operate a motor where a phase imbalance in supply voltage is greater than 2%.* Use the following formula to determine the % voltage imbalance:

$$\% \text{ Voltage Imbalance} = 100 \times \frac{\text{max voltage deviation from average voltage}}{\text{average voltage}}$$

Example: Supply voltage is 230-3-60

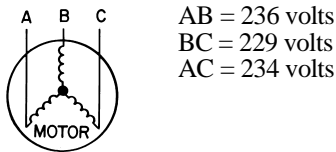

AB = 236 volts
BC = 229 volts
AC = 234 volts

$$\text{Average Voltage} = \frac{236 + 229 + 234}{3} = 233 \text{ volts}$$

Determine maximum deviation from average voltage:

- (AB) 236 – 233 = 3 volts
- (BC) 233 – 229 = 4 volts
- (AC) 234 – 233 = 1 volt

Maximum deviation is 4 volts. Determine % voltage imbalance:

$$\% \text{ Voltage Imbalance} = 100 \times \frac{4}{233} = 1.7\%$$

This amount of phase imbalance is satisfactory as it is below the maximum allowable of 2%.

IMPORTANT: If the supply voltage phase imbalance is more than 2%, contact your local electric utility company immediately.

ELECTRICAL DATA NOTES

1. All 06D and 07D units are across-the-line start.
2. Wire sizes are based on TW type copper wire. Maximum wire lengths based on data from Table 1 will result in a 1% voltage drop to compressor. Where up to 3% voltage drop is allowed, the run length can be increased to 3 times the length calculated from data in Table 1.
3. The 06D compressor unit electrical data shown in Table 1 does not apply for 06D compressors used as an integral part of other Carrier equipment. See proper installation book for electrical information.

WIRING — Power supply must correspond with unit nameplate electrical characteristics (units are internally wired at factory for nameplate voltage). Field wiring must comply with local and national codes.

Install a branch circuit fused disconnect of adequate size to handle starting current.

LINE POWER — Connect line power to the compressor contactor C. For example, connect L1 to terminal 11, L2 to terminal 12 and L3 to terminal 13. See Fig. 3.

Table 1 — Compressor Electrical Data

COMPRESSOR PART NUMBER 06D*		VOLTAGE (3 Ph-60 Hz)	HP	MCC	RLA	LRA	MOTOR WINDING RESISTANCE (Ohms)
M	808	575	3	7	5	28.4	5.0
		208/230		17.4	12.4	71	0.78
		460		8.7	6.2	35.5	3.1
	313	575	5	10.8	7.7	40	3.3
		208/230		27	19.3	100	0.5
		460		13.5	9.6	50	2.1
A	818	575	6.5	17.6	12.6	64	2.6
		208/230		44	31.4	160	0.42
		460		22	15.7	80	1.7
	825	575	7.5	22.2	15.9	79	2.0
208/230		55.5		39.6	198	0.31	
		460		27.8	19.8	99	1.3
	328	575	10	25	17.9	91	1.7
		208/230		62	44.3	228	0.26
		460		31	22.1	114	1.0
	537	575	15	32	22.9	96	1.2
		208/230		89	63.6	266	0.18
		460		40	28.6	120	0.72

LEGEND

- LRA** — Locked Rotor Amps
- MCC** — Maximum Continuous Current
- RLA** — Rated Load Amps

*Refer to physical data table to match compressor with correct compressor unit or water-cooled condensing unit.

NOTES:

1. RLA (rated load amps) value shown is: MCC ÷ 1.40 = RLA.
2. For minimum contactor sizing, use RLA value determined by: MCC ÷ 1.40 = RLA.

3. For wiring sizing, the RLA value can be determined by: MCC ÷ 1.56 = RLA.
4. Compressor operating amps at any specific conditions can only be determined from a performance curve.
5. RLA values for 06D compressor protected by a calibrated circuit breaker will depend on must-trip value of circuit breaker.
6. Ohm values shown for resistance are approximate and shown for reference only. Motors from different vendors and motors of different efficiencies can differ up to 15% from data shown.
7. Electrical data for compressor part numbers 06DR and 50 Hz models (not shown) are available from Carrier Sales Representative.

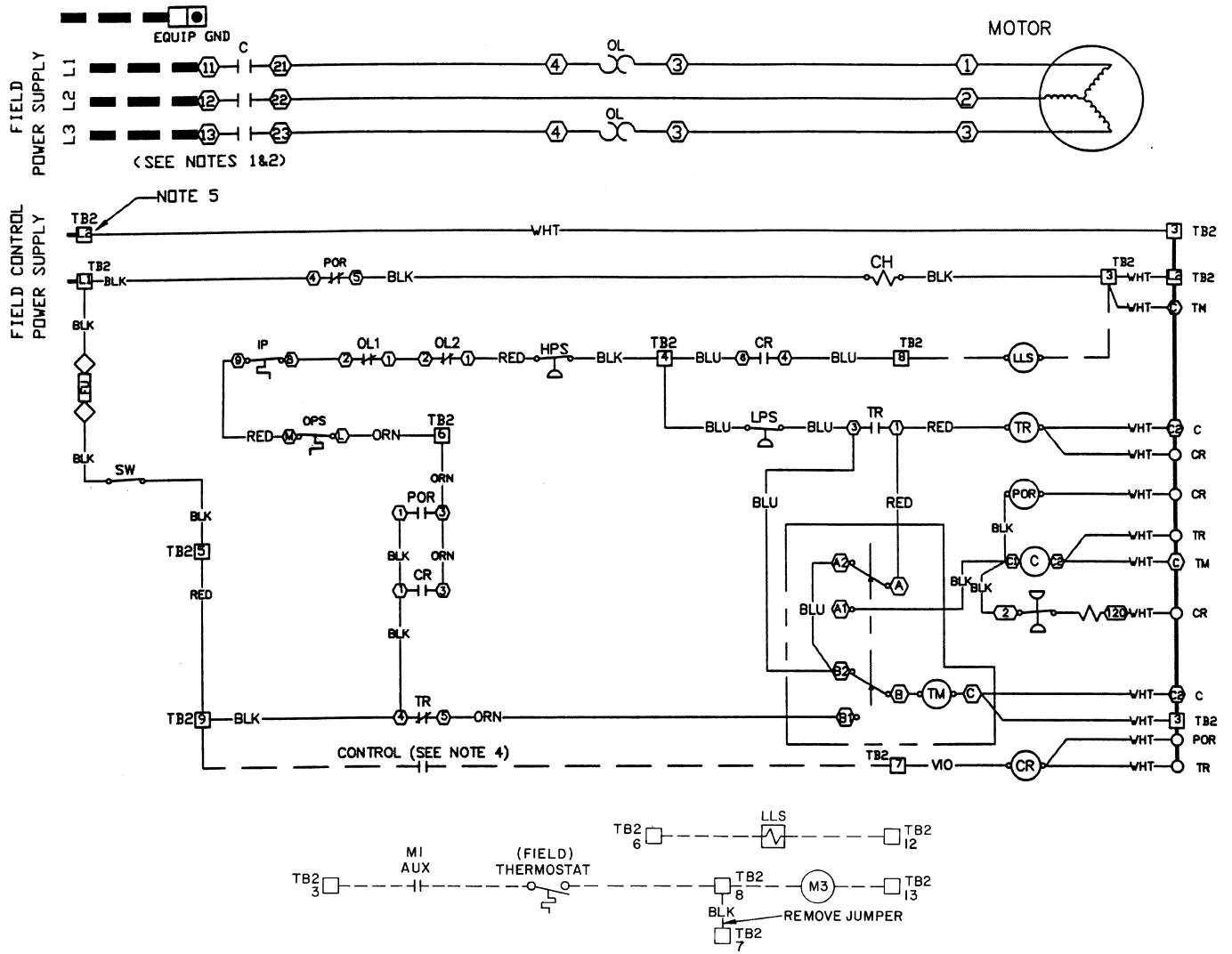

LEGEND

- | | |
|---|---|
| AUX — Auxiliary | TB — Terminal Block |
| C — Compressor Contactor | TM — Timer Motor |
| CH — Crankcase Heater | TR — Timer Relay |
| CR — Control Relay | □ Terminal Block Connector |
| DX — Direct Expansion | ○ Unmarked Terminal |
| EQUIP — Equipment | ⬡ Marked Terminal |
| FU — Fuse | — Factory Wiring |
| GND — Ground | - - - Field Control Wiring |
| HPS — High-Pressure Switch | ■ To indicate common potential only; not to represent wiring. |
| IP — Internal Protector | ○ Splice |
| LLS — Liquid Line Solenoid Valve | |
| LPS — Low-Pressure Switch | |
| M3 — Cooling Tower Fan | |
| NEC — National Electrical Code | |
| OL — Overload | |
| OPS — Oil-Pressure Switch | |
| POR — Pumpout Relay | |
| SW — Start-Stop-Reset Switch | |

NOTES:

1. Factory wiring is in compliance with NEC. Any field modifications or additions must be in compliance with all applicable codes. Use copper, copper-clad aluminum for field power supply only.
2. Field power supply wiring must be 75 C minimum.
3. Compressor thermally protected. Three-phase motors are protected against primary single-phasing condition.
4. Pilot duty control must be field supplied. Minimum contact rating must be 25 va.
5. 60 Hz units have 120-volt control circuit. 50 Hz units have 230-volt control circuit. A separate source of supply at the correct voltage must be field supplied through a fused disconnect device

6. Open control circuit disconnect switch for servicing only. Disconnect must remain closed for crankcase heater to operate.
7. A transformer of the following rating may be field supplied for 60 Hz units: 350 va.
8. Transformer must be fused and grounded per applicable codes.
9. If any of the original wiring furnished must be replaced, it must be replaced with 90 C wire or its equivalent.

Fig. 3 — Unit Label Diagram — 06D, 07D Units

Compressor Unit Connections — Extend power leads from control center (contactor terminals) to compressor terminal box and make connections as shown in Fig. 4.

Terminals 8 and 9 on motor terminal plate are for internal protector connections. As shown in Fig. 4, run a wire from terminal 9 to terminal 6 on TB2 in control center and a wire from terminal 1 on OL2 to terminal 2 on HPS in control center.

Run crankcase heater power wiring into control center. Connect leads to terminal 5 on pumpout relay and terminal 3 on terminal block TB2. See Fig. 5.

Affix power warning label supplied in the installer's packet to fused disconnect which energizes crankcase heater (see unit label diagram).

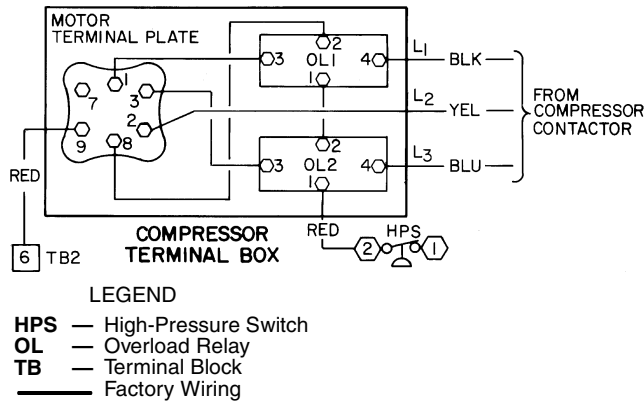

LEGEND
HPS — High-Pressure Switch
OL — Overload Relay
TB — Terminal Block
 — Factory Wiring

Fig. 4 — Compressor Terminal Diagram

CONTROL WIRING — Control circuit power is 115 volts, energized from an external source or from unit voltage through field-supplied transformer. Transformer size required is 350 va for 60 Hz units. External control power source must be supplied through a 15-amp fused disconnect. Connect control circuit power leads to terminal block TB2, terminals L1 and L2. Terminal L2 is neutral potential (ground).

Compressor Protection — The 06D and 07D units are factory wired for single-pumpout control. Field addition and wiring of line voltage remote control and liquid line solenoid valve is required. (See unit Fig. 3 and Fig. 6.) Remote control minimum contact rating must be 25 va. Solenoid valve must have a maximum load rating of 50 va holding; 200 va inrush. For applications with cooling tower, air-cooled or evaporative condensers, add necessary auxiliary contacts in line between compressor contactor and terminal A1 on timer. Insert desired interlocks and overloads between terminals 5 and 9 on terminal block TB2.

Control wiring may be modified as shown in Fig. 6 for *automatic pumpdown control*; remove low-pressure switch between timer relay and terminal 4 on TB2. Wire low-pressure switch between terminals 9 and 6 on TB2. Add necessary auxiliary contacts between compressor contactor and terminal A1 on timer. Remove wire between terminal 6 on TB2 and terminal 3 on pumpout relay. Insert required interlocks and overloads between terminals 5 and 9 on TB2.

Limitations — Do not use automatic pumpdown control on direct expansion cooler applications or when compressors are equipped with pressure-type unloader valves. Pressure unloader valves have built-in high to low passage which allows compressor to cycle with automatic pumpdown.

- LEGEND**
- | | |
|-----------------------------------|---------------------------------------|
| C — Contactor, Compressor | NEC — National Electrical Code |
| CH — Crankcase Heater | OL — Overload Relay |
| CR — Control Relay | OPS — Oil Pressure Switch |
| FU — Fuse | POR — Pumpout Relay |
| GND — Ground Connection | SW — Switch |
| HPS — High-Pressure Switch | TB — Terminal Block |
| IP — Internal Protector | TM — Timer Motor |
| LPS — Low-Pressure Switch | TR — Timer Relay |
- NOTES:**
1. Factory wiring is in compliance with NEC. Any field modifications or additions must be in compliance with all applicable codes. Use copper, copper-clad aluminum for field power supply only.
 2. Field power supply wiring must be 75 C minimum.
 3. Compressor thermally protected. Three-phase motors are protected against primary single-phasing condition.
 4. Pilot duty control must be field supplied. Minimum contact rating must be 25 va.
 5. 60 Hz units have 120-volt control circuit. 50 Hz units have 230-volt control circuit. A separate source of supply at the correct voltage must be field supplied thru a fused disconnect device with a max rating of 15 A to TB2 connections **L1** (Hot Side) and **L2** (Neutral).
 6. Open control circuit disconnect switch for servicing only. Disconnect must remain closed for crankcase heater to operate.
 7. A transformer of the following rating may be field supplied for 60 Hz units: 350 va.
 8. Transformer must be fused and grounded per applicable codes.
 9. If any of the original wiring furnished must be replaced, it must be replaced with 90 C wire or its equivalent.

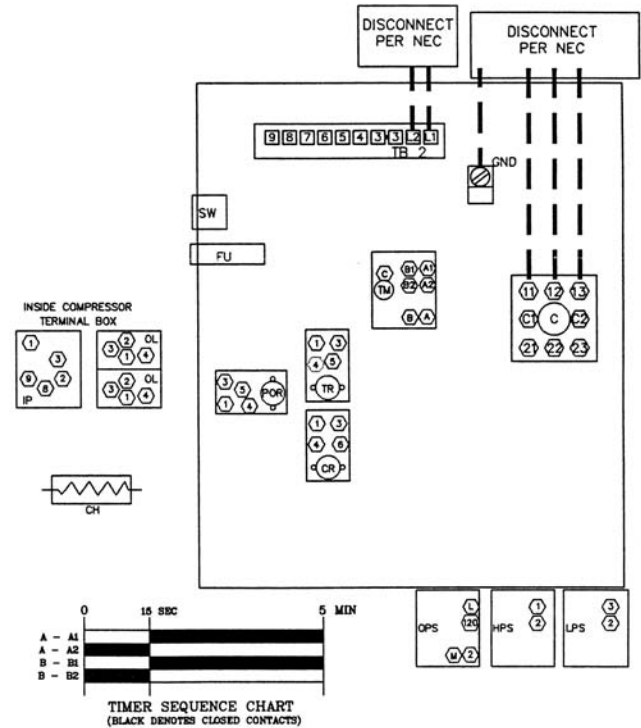
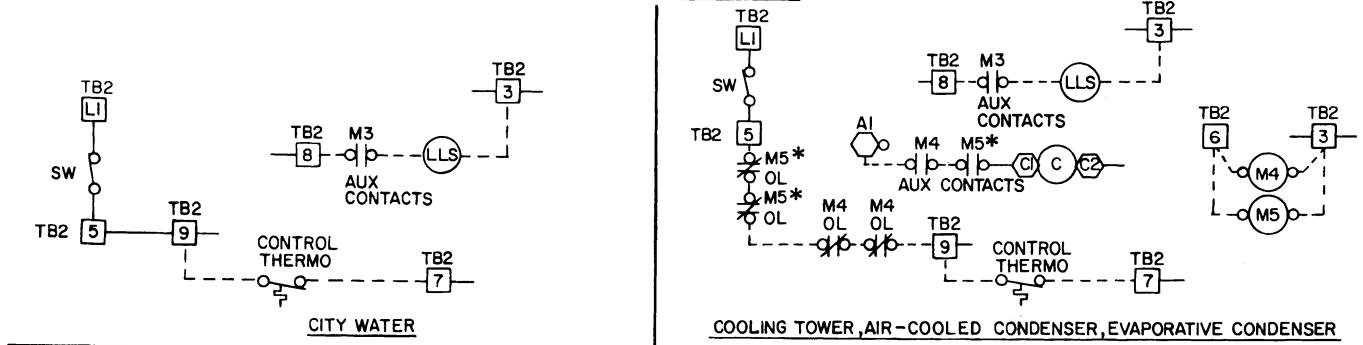

Fig. 5 — 06D/07D Control Box Components and Connections (3-Phase)

SINGLE PUMPOUT CONTROL



AUTOMATIC PUMPDOWN CONTROL

(SEE PAGE 6 FOR LIMITATIONS)

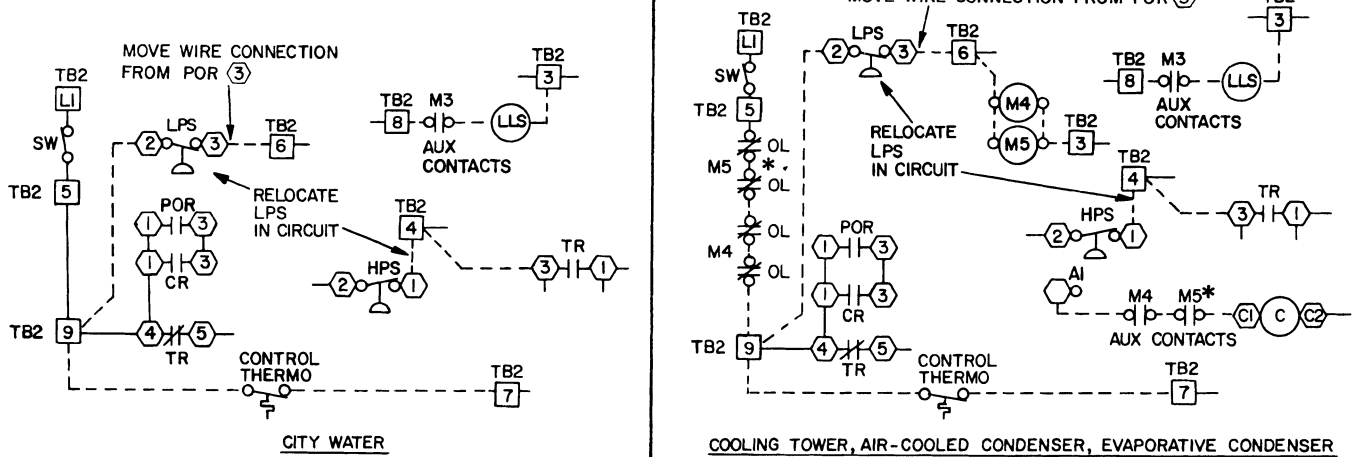

LEGEND

- | | |
|---|----------------------------|
| AUX — Auxiliary | OL — Overload Relay |
| C — Contactor | POR — Pumpout Relay |
| CR — Control Relay | SW — Switch |
| HPS — High-Pressure Switch | TB — Terminal Block |
| LLS — Liquid Line Solenoid Valve | TR — Timer Relay |
| LPS — Low-Pressure Switch | — Factory Wiring |
| M3 — Evaporator Fan or Chilled Water Pump | --- Field Wiring |
| M4 — Cooling Tower Pump, Air-Cooled or Evaporative Condenser Fan | |
| M5 — Cooling Tower Fan or Evaporative Condenser Pump | |
- *Optional.

Fig. 6 — Recommended Field Wiring

Refrigerant Charging

⚠ CAUTION

When charging, or when removing charge, circulate water through water-cooled condenser(s) and cooler continuously to prevent freezing. Freezing damage is considered abuse and is not covered by Carrier warranty.

EVACUATE, DEHYDRATE AND LEAK TEST — Entire refrigerant system must be evacuated, dehydrated and leak tested by methods described in Carrier Standard Service Techniques Manual, Chapter 1, Sections 1-6 and 1-7. Use sight glass method to charge system. See Section 1-8 of manual for details.

CHARGE THE SYSTEM — Charge to a clear sight glass while holding saturated condensing pressure constant at 125 F (air-cooled systems) or 105 F (water-cooled systems). Add additional refrigerant to fill condenser subcooler coils, where applicable, for air-cooled applications.

06D Compressor Units — See condenser data for additional charge required to fill subcooler after clear sight glass is obtained.

INITIAL START-UP

⚠ DANGER

Do not attempt start-up with terminal cover removed. Bodily injury or death may result from explosion and/or fire if power is supplied to compressor with the terminal cover removed or unsecured. See warning label on terminal cover.

Crankcase heater should be energized a minimum of 24 hours before starting unit. *Do not permit crankcase heaters to be deenergized during normal shutdown periods.*

Check to see that oil level is $\frac{1}{3}$ to $\frac{2}{3}$ up on compressor sight glass.

Open water supply valve and allow water to reach condenser. Open pressure line valve of water regulating valve, if used. (Turn condenser fan on when the compressor unit is applied with air-cooled condenser.)

Backseat (open) the compressor suction and discharge shutoff valves; open liquid line valve at receiver.

Start evaporator fan or chilled water pump.

To Start Compressor — Close main power switch, control power switch, and unit ON-OFF switch. Time Guard® control circuit causes a short delay before compressor starts.

Recheck oil level and check oil pressure. See Oil Charge for details.

With unit operating, voltage at compressor terminals must be within limits shown on nameplate. Phases must be balanced within 2% of voltage (refer to Electrical Connections section). Contact local power company for correction of improper line voltage or phase imbalance. Operation of unit on improper line voltage or with excessive phase imbalance constitutes abuse and is not covered by Carrier Warranty.

NOTE: *The 06D, 07D unit safety controls are of the automatic-reset type. If compressor is shut off by a safety control, do not permit control to reset more than once before determining cause of shutdown.*

CHECKING OPERATION

Refer to Carrier Standard Service Techniques Manual, Chapter 2 for complete instructions on checking electrical components.

Oil Charge (See Tables 2A and 2B) — Check oil level in compressor sight glass after 15 to 20 minutes of operation. If oil level is low, add oil according to methods described in Carrier Standard Service Techniques Manual, Chapter 1 (Section 1-11). Add oil through suction manifold connection on 4-cylinder compressors, and oil port on 6-cylinder compressors.

The preferred method for a complete recharge is to $\frac{1}{2}$ sight glass with compressor shut down.

When additional oil, or a complete charge, is required, use only Carrier-approved compressor oil.

Approved* oils are:

Witco Suniso 3GS
Texaco, Inc. Capella WF-32

*Oils approved for R-12, R-22, R-502 Carrier refrigerants. For other refrigerants, contact Carrier Factory Sales Representative.

IMPORTANT: Do not reuse drained oil and do not use oil that has been exposed to atmosphere.

High-Pressure Switch — Check by throttling condenser water or blocking airflow on air-cooled units, allowing head pressure to rise gradually. Check discharge pressure constantly throughout procedure. Compressor should shut off within 10 psi of values shown in Table 3.

Low-Pressure Switch — Check by slowly closing suction shutoff valve or by completely closing liquid line shutoff valve. A decrease of suction pressure will follow. Compressor should shut off within 4 psi of values shown in Table 3.

Oil Pressure Switch (OPS) — The oil pressure switch protects against damage from loss of oil or loss of oil pressure during unit start-up. If the oil pressure differential sensed by the OPS is 6 psig or less on unit start-up, the switch remains closed and the OPS heater is energized.

The switch time delay is approximately 45 seconds. If after 45 seconds the oil pressure differential sensed by the OPS is less than 11 psig, the heater remains energized. The OPS temperature actuated switch then opens and the compressor is deenergized. If the differential reaches 11 psig, the OPS opens and deenergizes the heater and the system operates normally.

IMPORTANT: If the oil pressure switch causes unit lockout, determine and correct the cause of the lockout (such as loss of compressor oil or flooded compressor) before restarting the unit. Failure to correct the cause of OPS lockout may constitute abuse. Equipment failure due to abuse is not covered by warranty.

To restart the unit, push the OPS reset button and then push the control circuit switch on the unit control box to OFF and then to ON.

Time Guard® Control — Control provides a delay of approximately 5 minutes before restarting compressor after shutdown for any reason. On starting, the Time Guard control timer causes a delay of 15 seconds after thermostat closes before compressor will start.

Table 2A — 06D Physical Data

UNIT 06D	A8081	H3131	A8181	E8251	E3281	E5371
OPERATING WEIGHT (lb)	180	250	265	325	325	330
REFRIGERANT	R-134a, R-22, R-507/404A					
COMPRESSOR — 06D*	M808	M313	A818	A825	A328	A537
Cylinders	2	4	4	6	6	6
Bore (in.)	2	2	2	2	2	2
Stroke (in.)	1 ¹ / ₄	1	1 ⁷ / ₁₆	1 ¹ / ₄	1 ¹⁵ / ₃₂	1 ¹⁵ / ₁₆
Displacement (cfm at 1750 rpm)	8	13	18.3	23.9	28	37.1
Maximum Rpm	1750					
Oil Charge (pt)	3	4.5	5.5	8	8	8
High Side Maximum Pressure	450 PSIG					
Low Side Maximum Pressure	245 PSIG					
CONNECTIONS (in.)						
Suction Valve (ODF)	7/8	7/8	1 ¹ / ₈	1 ³ / ₈	1 ³ / ₈	1 ³ / ₈
Discharge Valve (ODF)	5/8	5/8	7/8	7/8	7/8	1 ¹ / ₈

*Compressors listed are for R-22 applications. For R-134a and R-507/404A an 06DR compressor is standard. Factory compressor substitutes may be made. Contact Carrier Sales Representative.

→ NOTE: The 06DE8251 compressor unit with the 06DA825 compressor replaces the 06DE8241 once inventory of the 06DA824 compressor is depleted.

Table 2B — 07D Physical Data

UNIT 07D	A203	B205	A208	B210	B212	B215	
OPERATING WEIGHT (lb)	270	395	420	545	595	620	
REFRIGERANT	R-134a, R-22, R-507/404A						
COMPRESSOR — 06D*	M808	M313	A818	A825	A328	A537	
Cylinders	2	4	4	6	6	6	
Bore (in.)	2	2	2	2	2	2	
Stroke (in.)	1 ¹ / ₄	1	1 ⁷ / ₁₆	1 ¹ / ₄	1 ¹⁵ / ₃₂	1 ¹⁵ / ₁₆	
Displacement (cfm at 1750 rpm)	8	13	18.3	23.9	28	37.1	
Maximum Rpm	1750						
Oil Charge (pt)	3	4.5	5.5	8	8	8	
High Side Maximum Pressure	450 PSIG						
Low Side Maximum Pressure	245 PSIG						
CONDENSER (Shell and Tube)† Part Number	P701-0605CX	P701-0607CX	P701-0610CX	P701-0615CX	P701-0620CX	P701-0625AX	
Refrigerant Storage Capacity (lb)	R-134a	17.20	15.90	24.40	31.60	27.40	39.80
		2.86	3.16	5.00	7.55	8.47	9.18
Min Refrigerant Operating Charge (lb)	R-22	17.00	15.70	24.10	31.20	27.10	39.30
		2.80	3.10	4.90	7.40	8.30	9.00
	R-507/404A	14.70	13.60	20.90	27.10	23.50	34.10
		2.80	3.10	4.90	7.40	8.30	9.00
REFRIGERANT CONNECTION (in. ODF)							
Inlet	1 ⁵ / ₈	1 ⁵ / ₈	1 ⁵ / ₈	1 ⁵ / ₈	1 ⁵ / ₈	1 ⁵ / ₈	
Outlet	1 ¹ / ₈	1 ¹ / ₈	1 ¹ / ₈	1 ¹ / ₈	1 ¹ / ₈	1 ¹ / ₈	
WATER CONNECTION (in. FPT)							
Inlet/Outlet	1	1	1 ¹ / ₄	1 ¹ / ₄	1 ¹ / ₄	2	

LEGEND

FPT — Female Pipe Thread
ODF — Outside Diameter, Female

†The condenser listed is for R-22, air conditioning duty and may change based on the application. Maximum condenser operating pressure: 350 psi refrigerant side, 300 psi water side ("CX" models); 350 psi refrigerant side, 150 psi water side ("AX" models).

*Compressor listed is the standard compressor for R-22, air conditioning duty. An 06DR compressor is standard equipment for low temperature (R-507/404A) or medium temperature (R-134a) applications. Factory substitutions may be made. Contact Carrier Sales Representative.

→ NOTE: The 07DB210 with the 06DA825 compressor replaces the 07DB210 with the 06DA824 once the compressor inventory is depleted.

Table 3 — Factory Switch Settings

SWITCH TYPE	PRESSURE CHANGE AFFECTING SWITCH POSITION	
	Closed	Open
High Pressure	210 (±10) (psig)	290 (±10) (psig)
Low Pressure	70 (±4) (psig)	60 (±4) (psig)
Oil Pressure	6 (psid)	11 (psid)

LEGEND

psid — pounds per square inch differential
psig — pounds per square inch gage

NOTES:

- Values for the high- and low-pressure switches based on R-22. For other refrigerants, reset to pressure corresponding to saturation temperatures indicated by the listed pressures.
- Values for oil pressure are above operating suction pressure (pressure differential between suction and discharge pressures of oil pump).

CAPACITY CONTROL (Suction Cutoff Type)

Control Set Point (Cylinder Load Point) — Set point is adjustable from 0 to 86 psig. Pressure differential between cylinder load-up point and cylinder unload point is adjustable from 7 to 19 psi.

To Regulate Control Set Point — Refer to Fig. 7. Turn adjustment nut clockwise to its bottom stop (with nut in this position, set point is 86 psig). Control set point is then regulated to desired pressure by turning adjustment nut counterclockwise. Every full turn decreases set point by 7.2 psi. Approximately 12 turns in counterclockwise direction will decrease control set point to 0 psig. Table 4 shows steps of control for the compressor and condensing unit.

Pressure Differential Adjustment — Turn differential adjusting screw counterclockwise to its back-stop position (differential in this position is 7 psi). Pressure differential is set by turning adjustment screw clockwise. Every full turn increases differential by 1.2 psi. Approximately 10 turns in clockwise direction will increase pressure differential to 19 psi.

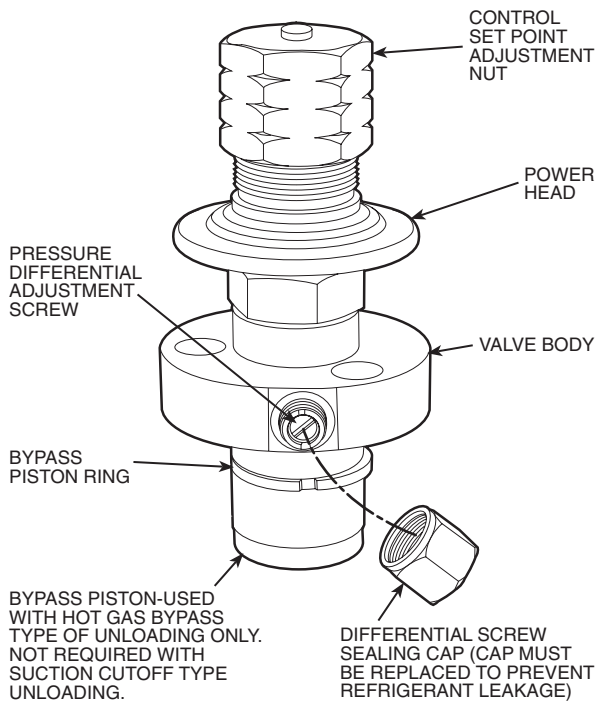

Fig. 7 — Capacity Control Valve (Pressure Type)

Table 4 — Capacity Control Reduction Steps

UNIT 06D,07D	NO. OF CONTR CYL	% Full Load Capacity			
		100	67	49	32
		% Full Load kW			
		100	73	57	46
		Number of Active Cylinders			
ALL 4 CYLINDER MODELS	2	4	—	2	—
ALL 6 CYLINDER MODELS	4	6	4	—	2

Capacity Control Pressure (Fig. 8)

LOADED OPERATION — Pressure-operated control valve is controlled by suction pressure and actuated by discharge pressure. Each valve controls 2 cylinders (one bank). On start-up, controlled cylinders do not load up until differential between suction and discharge pressures is approximately 25 psi.

When suction pressure rises high enough to overcome control set point spring, the diaphragm snaps to the left and relieves pressure against the poppet valve. The drive spring

moves the poppet valve to left and it seats in the closed position.

With poppet valve closed, discharge gas is directed into the unloader-piston chamber and pressure builds up against the piston. When pressure against unloader piston is high enough to overcome the unloader valve spring, piston moves valve to the right, opening suction port. Suction gas can now be drawn into the cylinders and the bank is running fully loaded.

UNLOADED OPERATION — As suction pressure drops below set point, control spring expands, snapping diaphragm to right. This forces poppet valve open and allows gas from discharge manifold to vent through base of control valve to suction side. Loss of full discharge pressure against unloader piston allows unloader valve spring to move valve left to closed position. The suction port is blocked, isolating the cylinder bank from the suction manifold. The cylinder bank is now unloaded.

CONDENSER MAINTENANCE

To inspect and clean condenser, drain water and remove condenser heads. To drain condenser, shut off water supply and disconnect inlet and outlet piping. Remove drain plugs and vent plug.

With condenser heads removed, inspect tubes for refrigerant leaks. (Refer to Carrier Refrigerant Service Techniques Manual.)

Clean condenser tubes with nylon brush (available from Carrier Service Department). Flush water through tubes while cleaning. If hard scale has formed, clean tubes chemically. Do not use brushes that will scrape or scratch tubes.

Because the condenser water circuit is usually an open system, the condenser tubes may be subject to contamination by foreign matter. Local water conditions may cause excessive fouling or pitting of tubes. Condenser tubes, therefore, should be cleaned at least once a year or more often if the water is contaminated.

Proper water treatment can minimize tube fouling and pitting. If such conditions are anticipated, water treatment analysis is recommended. Refer to the Carrier System Design Manual, Part 5, for general water conditioning information.

If hard scale has formed, clean the tubes chemically. Consult an experienced and reliable water-treatment firm in your area for treatment recommendations. Clean the condenser by gravity or by forced circulation as shown in Fig. 9 and 10.

IMPORTANT: If the ambient temperature is below 32 F during a shutdown period; protect the condenser from freezing by draining the water from the system or by adding antifreeze to the water.

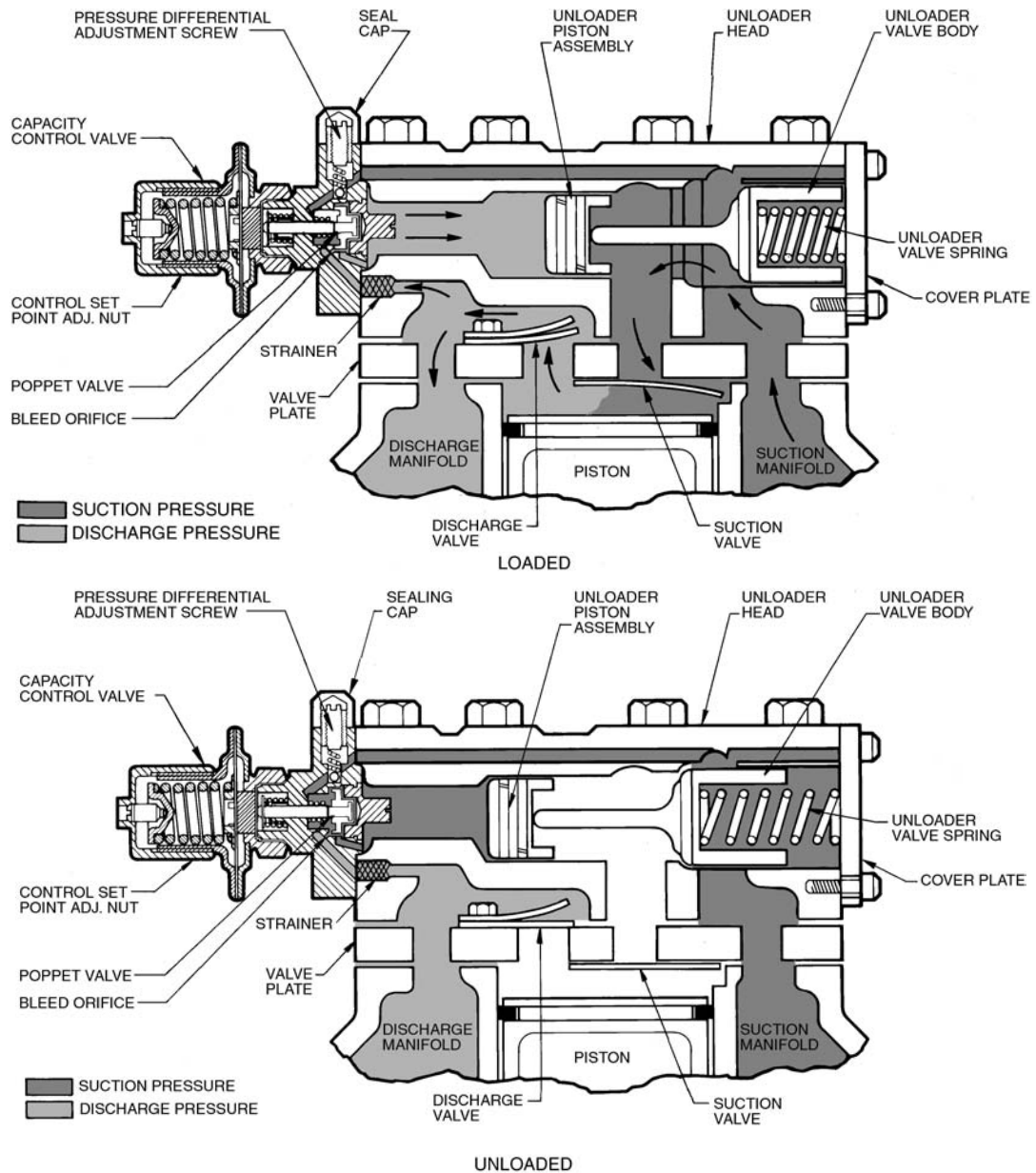

Fig. 8 — Capacity Control Valve Operation

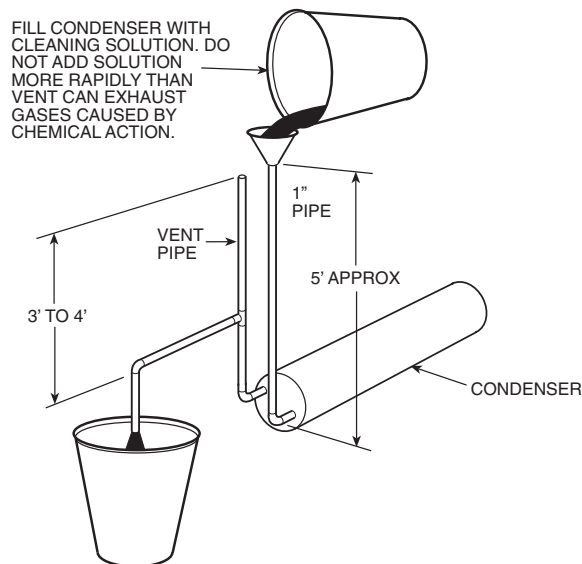

Fig. 9 — Gravity Circulation

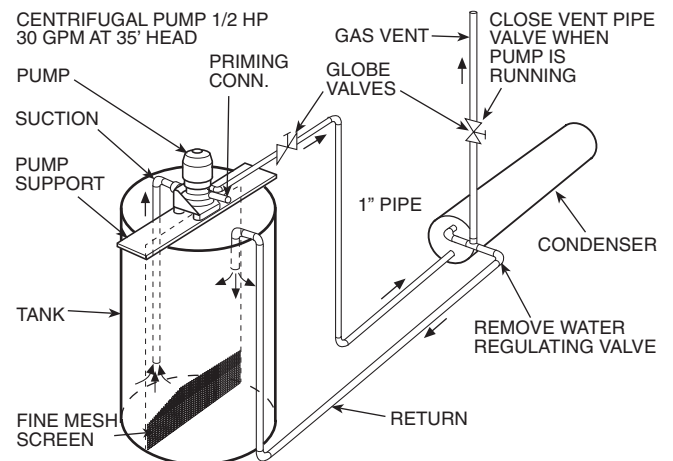

Fig. 10 — Forced Circulation

SERVICE

⚠ DANGER

Do not remove the compressor terminal box cover until all electrical power is disconnected and pressure is relieved. Terminal pins may blow out causing injuries, death, and/or fire.

Service Notes

- Where compressor components are shown, they are in normal order of removal from compressor.
- For replacement items, use Carrier specified parts. See Carrier 06D Specified Parts list for compressor part interchangeability.
- Before compressor is opened, the refrigerant must be removed from it by the Pumpdown method.
 - Start compressor, close suction shutoff valve, and reduce crankcase pressure to 2 psig (bypass low pressurestat with jumper).
 - Stop compressor and isolate from system by closing discharge shutoff valve.
 - Bleed any residual refrigerant. Drain oil if necessary.
- After disassembly, clean all parts with solvent. Use mineral spirits, white gasoline or naphtha.
- Before assembly, coat all parts with compressor oil and clean and inspect all gasket surfaces. Replace all gaskets with new standard specified gaskets, coated with compressor oil. See Table 5 for typical torque values.
- After reassembly, evacuate compressor and open suction and discharge valves. Restart compressor and adjust refrigerant charge.

Table 5 — Torque Values

SIZE DIAM (in.)	THREADS PER IN.	TORQUE RANGE (lb-ft)	USAGE
1/16	27 (pipe)	8-12	Pipe Plug — Crankshaft
1/8	20 (pipe)	6-10	Oil Return Check Valve — Crankcase
	20 (pipe)	20-25	Pipe Plug — Press. Gage Conn.
1/4	20	10-12	Connecting Rod Capscrew
	28	12-15	Baffle Plate — Crankcase
		12-15	Side Shield
		12-15	Oil Pump Drive Segment
12-15		Unloader Valve	
5/16	18	16-20	Cover Plate — Pump End Bearing Head
		16-20	Terminal Block Cap Screws
		20-25	Suction Service Valve
		20-25	Discharge Service Valve
3/8	16	30-35	Pump End Bearing Head
		30-35	Bottom Plate — Crankcase
		30-35	Compressor Foot
		30-35	Cylinder Head
		30-35	Motor End Cover — Crankcase
7/16	14	55-60	Motor End Cover — Crankcase
1/2	13	80-90	Suction Service Valve
5/8	11	25-30	Crankshaft Spinner Tube
No. 10	32	4- 6	Oil Pump Drive Segment
1 1/2	18 NEF	35-45	Oil Level Sight Glass

LEGEND

NEF — National Extra Fine

Testing Oil Pump — Observe oil level sight glass. The oil pressure relief valve line is positioned to discharge oil against sight glass. When oil does not discharge from this line, it is an indication of low oil pump pressure.

If oil pump pressure is low, remove and check oil filter screen, oil pressure regulator and oil return check valve.

OIL PRESSURE RELIEF VALVE (Fig. 11) — Unscrew relief valve assembly from motor partition plate, and be sure assembly is not clogged or the plunger is not stuck.

OIL RETURN CHECK VALVE (Fig. 11) — Unscrew check valve from motor partition plate. Be sure flutter valve is not sticking and that it seats tightly.

OIL FILTER SCREEN (Fig. 12) — Screen is accessible through bottom cover plate. Remove and inspect strainer for holes and dirt. Clean it with solvent and replace.

OIL PUMP AND BEARING HEAD (Fig. 12) — The oil pump assembly is contained in the pump end bearing head aluminum casting. The pump end main bearing is a machined part of this casting. An insert bearing is not required.

Remove Bearing Head Assembly from Crankcase — Remove in sequence (refer to Fig. 12 and 13): oil pump cover, oil feed guide retaining spring, oil feed guide, pump drive segment. If damage to the oil pump or main bearing is found, a new pump end bearing head assembly should be installed.

Replace (Refer to Fig. 12 and 13) — For torque values, refer to Table 5. Following steps are used to replace bearing head:

- Bolt bearing head to crankcase. Place pump drive segment into position and secure to end of crankshaft with cap screws and lock washers that were removed (see Fig. 13).
- Insert oil feed guide with large diameter inward and place guide retainer spring over small diameter of guide.
- Install gasket and oil pump cover.

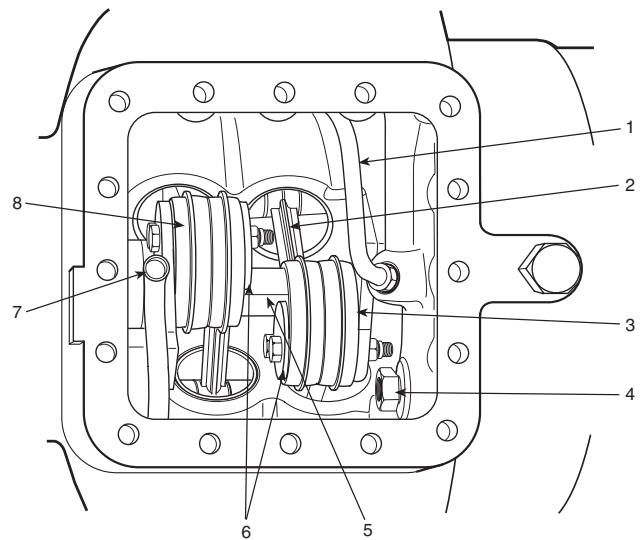

LEGEND

- | | |
|-------------------------------|---------------------------------|
| 1 — Oil Pressure Relief Valve | 5 — Eccentric Shaft |
| 2 — Piston and Eccentric | 6 — Eccentric Strap Side Shield |
| 3 — Motor End Counterweight | 7 — Oil Suction Tube |
| 4 — Oil Return Check Valve | 8 — Pump End Counterweight |

Fig. 11 — Compressor (Bottom Plate Removed)

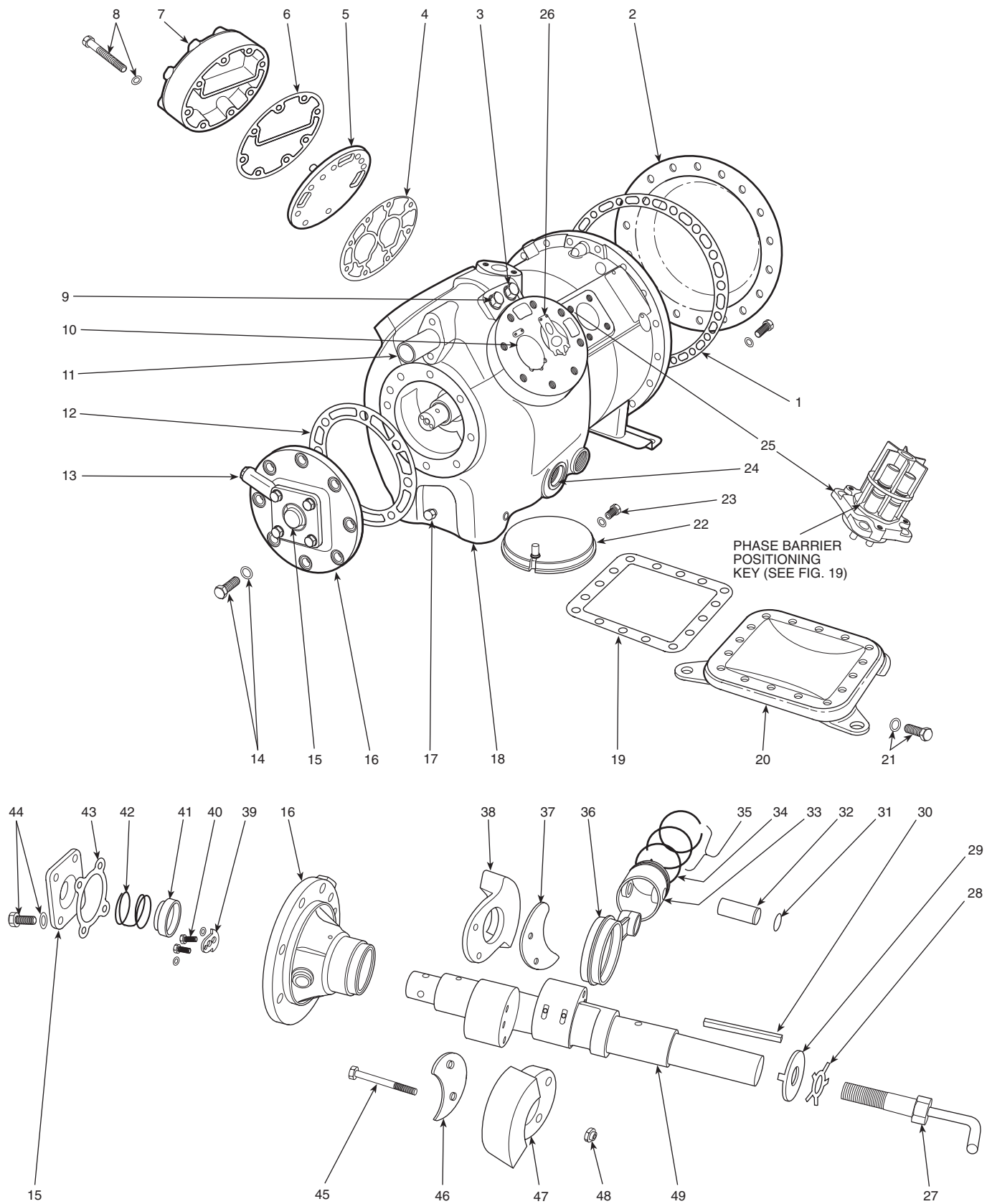
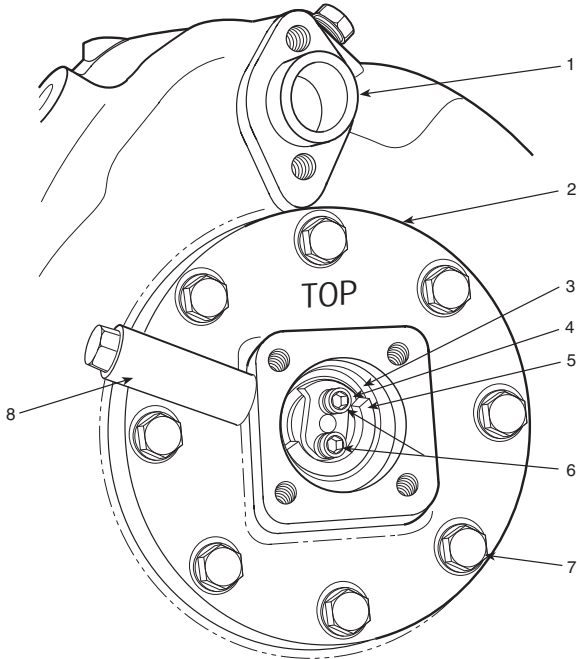

Fig. 12 — 06D Compressor Components (4-Cylinder with Eccentric Shaft Shown)

LEGEND FOR FIG. 12

- | | | |
|--|---|---|
| 1 — Motor Cover Gasket | 17 — Oil Drain Plug | 34 — Oil Ring |
| 2 — Motor End Cover | 18 — Crankcase | 35 — Compression Rings |
| 3 — Discharge Manifold Connection | 19 — Bottom Plate Gasket | 36 — Eccentric Strap |
| 4 — Valve Plate Gasket | 20 — Bottom Plate | 37 — Eccentric Strap Side Shield |
| 5 — Valve Plate Assembly | 21 — Bottom Plate Washer and Cap Screw | 38 — Pump End Counterweight |
| 6 — Cylinder Head Gasket | 22 — Oil Filter Screen | 39 — Oil Pump Drive Segment |
| 7 — Cylinder Head | 23 — Oil Return Check Valve | 40 — Drive Segment Cap Screws and Lockwashers |
| 8 — Cylinder Head Washer and Cap Screw | 24 — Oil Level Sight Glass | 41 — Oil Feed Guide |
| 9 — Suction Manifold Connection* | 25 — Motor Terminal Plate | 42 — Oil Feed Guide Retainer Spring |
| 10 — Suction Valve Positioning Spring | 26 — Dowel Pins (For Suction Valve Positioning) | 43 — Cover Gasket |
| 11 — Suction Strainer | 27 — Equalizing Tube and Lock Screw Assembly | 44 — Pump Cover Cap Screw and Washer |
| 12 — Bearing Head Gasket | 28 — Lockwasher | 45 — Counterweight Bolt |
| 13 — Oil Pump Inlet Passage | 29 — Rotor Lockwasher | 46 — Eccentric Strap Side Shield |
| 14 — Bearing Head Washer and Cap Screw | 30 — Rotor Drive Key | 47 — Motor End Counterweight |
| 15 — Oil Pump Cover | 31 — Piston Pin Lock Ring | 48 — Locknut |
| 16 — Pump End Bearing Head | 32 — Piston Pin | 49 — Eccentric Shaft (or Crankshaft) |
| | 33 — Piston | |

*Used to add compressor oil.



LEGEND

- | | |
|------------------------------------|------------------------------|
| 1 — Suction Strainer Assembly | 5 — Oil Pump Rotor |
| 2 — Oil Pump Bearing Head Assembly | 6 — Drive Segment Cap Screws |
| 3 — Rotor Retaining Ring | 7 — Bearing Head Cap Screws |
| 4 — Oil Pump Drive Segment | 8 — Oil Pump Inlet Passage |

Fig. 13 — Removing Pump End Bearing Head

Three Allen head cap screws hold capacity control valve in place (Fig. 14). Remove screws using a cut-down $\frac{3}{16}$ -in. Allen wrench, and pull valve from cylinder head.

Remove same number of piston plugs from replacement compressor as number of unloaders supplied with original compressors. Three Allen head cap screws hold piston plug assembly in place. Remove flange cover, gasket, spring and bypass piston plug (Fig. 15). A tapped hole is provided in piston to allow it to be pulled out. Hole has same thread diameter as cap screws removed above.

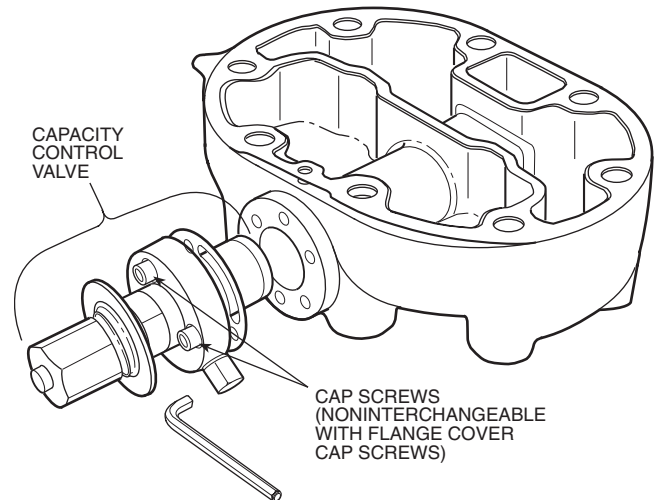

Fig. 14 — Removal of Capacity Control Valve

Cylinder Heads — Disassemble cylinder heads by removing cap screws and prying up on side *between cylinder head and valve plate* to break heads loose from valve plate. *Do not strike cylinder heads to break loose.*

Check heads for warping, cracks and damage to gasket surfaces. When replacing cylinder head, torque cap screws 30 to 35 lb-ft to prevent high to low side leak in center portion of cylinder head gasket.

Service Replacement Compressors — Replacement compressors are not equipped with control valves. One or both side bank cylinder head(s) is plugged with a spring loaded plug piston assembly. Compressor will run fully loaded with piston plug(s) in place.

Transfer original capacity control valve(s) to replacement compressor (ensures proper valves are used with correct setting). For sealing purposes, install a plug piston assembly into each cylinder head of original compressor from which a control valve was removed.

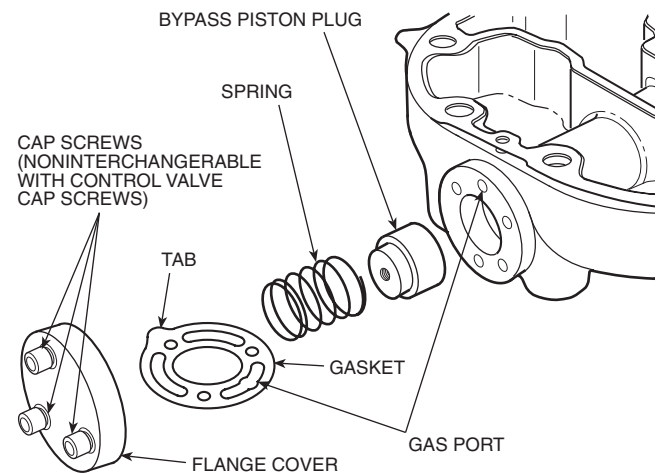

Fig. 15 — Removal of Bypass Piston Plug

Suction and Discharge Valve Plate Assembly (Fig. 16) — Test for leaking discharge valves by pumping compressor down and observing suction and discharge pressure equalization. If a discharge valve is leaking, the pressures will equalize rapidly. Maximum allowable discharge pressure drop is 3 psi per minute after an initial drop of 10 to 15 psi in the first half minute.

If there is an indicated loss of capacity and discharge valves check properly, remove suction and discharge valve plate assembly and inspect suction valves.

IMPORTANT: This test procedure is not applicable to compressors equipped with pressure actuated or solenoid unloader valves due to rapid pressure equalization rate. Check suction and discharge valves by disassembling valve plate (see Fig. 16).

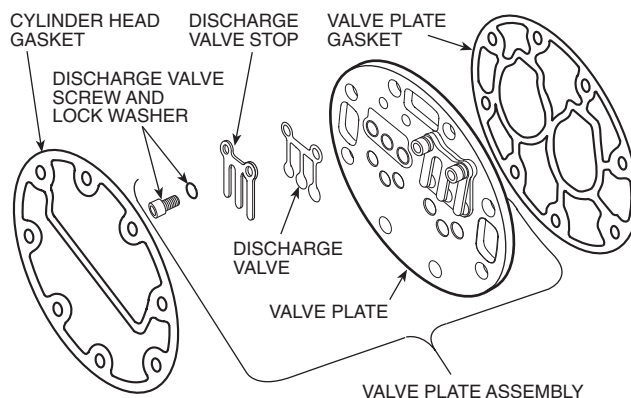

Fig. 16 — Valve Plate Assembly

DISASSEMBLY — Remove cylinder head.

1. Remove discharge valve assembly: cap screws, valve stops, valve stop supports and valves.
2. Pry up on side of valve plate, between valve plate and cylinder deck, to remove valve plate and expose suction valves. Remove suction valves and suction valve positioning springs from dowel pins.

Inspect valves and valve seats for wear and damage. See Table 6. Check cylinder deck valve stops for uneven wear. Replace valves if cracked or worn. If valve seats are worn, replace complete valve plate assembly. If cylinder deck valve stops are worn, replace compressor.

REASSEMBLY — Do not interchange valves. Install suction valve positioning springs on dowel pins. Assemble positioning springs with spring ends bearing against cylinder deck (Fig. 17). Springs bow upward. Place suction valves on dowel pins, over positioning springs. Place valve plate on cylinder deck, and reinstall discharge valve plate assembly. Retorque discharge valve stop cap screws to 16 lb-ft. Replace cylinder head. Be sure cylinder head gasket is lined up correctly with cylinder head and valve plate.

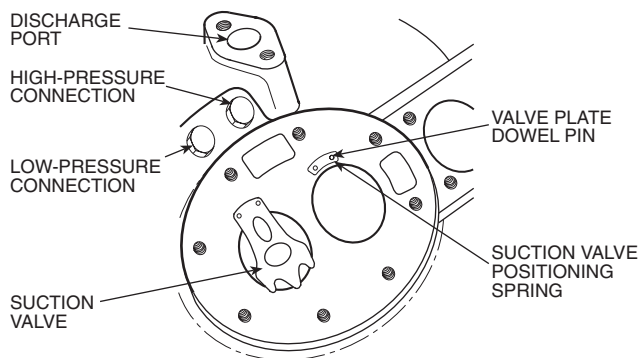

Fig. 17 — Suction Valve and Positioning Springs in Place

Table 6 — Compressor Wear Limits (Factory Tolerances) (in.)

COMPRESSOR PART	COMPRESSOR MODEL						MAX* ALLOW WEAR	
	06DM808	06DM313	06DA818	06DA825†	06DA328	06DA537		
MOTOR END								
Main Bearing Diameter	1.3755		1.3735			1.6240	0.002	
Journal Diameter	1.3755		1.6233				0.002	
PUMP END								
Main Bearing Diameter	1.3745						0.002	
Journal Diameter	1.3735						0.002	
CRANKPIN DIAMETER	2.2030		1.3735	2.2030	1.3735		0.0025	
THROW	Max	1.2500	1.0000	1.4374	1.2500	1.9396	—	
	Min	1.2460	—	1.4344	1.246	—	—	
THRUSTWASHER	Max	—		0.1570			0.025	
	Min	—		0.1550			0.025	
ECCENTRIC DIAMETER	Max	2.2035		—	2.2035	—	0.002	
CONN. ROD DIAMETER	Max	—		1.3755	—	1.3755	0.002	
PISTON PIN BEARING	Min	0.6878						0.001
CYLINDERS								
Bore	Max	2.0005						0.002
Piston Diameter	Min	1.996						0.002
Piston Pin Diameter	Min	0.6873						0.001
Piston Pin Bearing		Press Fit						—
Piston Ring Gap	Max	0.0130						0.025
	Min	0.0050						0.025
Piston Ring Side Clearance	Max	0.0020						0.002
	Min	0.0010						0.002

*Maximum allowable wear above maximum or below minimum factory tolerances shown. For example: difference between pump end main bearing diameter and journal diameter is .001 in. (1.3745 – 1.3735) per factory tolerances. Maximum allowable difference is .004 in. (.002 + .002).

†Tolerance for the 06DA825 same as 06DA824.

Cleaning Suction Strainer

1. Pump down compressor.
2. Remove motor end cover and screws holding disc type strainer (Fig. 18) to cover.
3. Clean strainer with solvent or replace if broken or corroded.
4. Replace strainer and motor end cover. Purge or evacuate compressor before starting.

Motor Replacement — Stator and rotor are not field replaceable. Stator is a press fit into motor housing. If compressor motor is damaged, replace compressor.

Terminal Plate Assembly — The terminal plate assembly is shown in Fig. 19. Do not disassemble for any reason except to replace the phase barrier, which may become damaged. *If refrigerant leakage or a ground short occurs, the entire terminal plate assembly must be replaced.*

If it becomes necessary to remove the phase barrier, proceed as follows:

1. Loosen and remove all terminal nuts.
2. Remove lock washers and wire terminals.
3. Loosen and disengage the center screw. (Do not try to remove the screw.)
4. Lift the phase barrier off the terminal screws (the spacers and the center screw are removed with the phase barrier).

IMPORTANT: Do not disturb the jam nuts on which the phase barrier rests.

Procedure for reassembling the phase barrier:

1. Place phase barrier over the terminal screws. *Be sure positioning key is in the recess in the terminal plate before proceeding further.*
2. Place the spacers and wire terminals on the terminal screws.
3. Place the lock washers and terminal nuts over the wire terminals and tighten to specified torque (18 to 30 lb-in.).
4. Install the center screw through the phase barrier and tighten to the specified torque (15 to 25 lb-in.).

NOTE: *The design allows for clearance between the center screw head and the phase barrier. Thus, the torque limit may be reached before the screw head contacts the phase barrier. This condition is acceptable.*

Compressor Running Gear Removal

1. Remove pump end bearing head.
2. Remove motor end cover carefully to prevent damage to stator. Support cover and lift off horizontally until it clears windings.
3. Remove bottom cover plate.
4. Remove equalizer tube assembly from motor end of crankshaft (or eccentric shaft). If shaft turns, preventing tube assembly from being loosened, block shaft with a piece of wood.
5. Remove rotor using a jackbolt. Insert a brass plug into rotor hole to protect end of crankshaft from jackbolt. Support rotor while it is being removed to prevent stator damage.
6. Remove connection rod caps from compressors using connecting rods and crankshafts. *Label caps and rods so they may be reinstalled in same plate on crankshaft.*

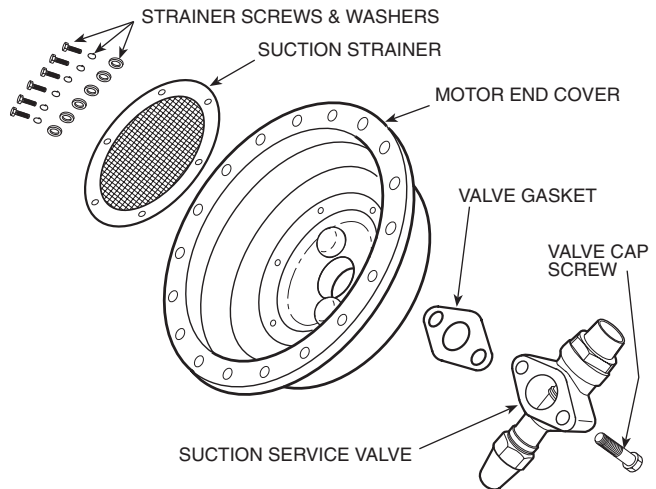
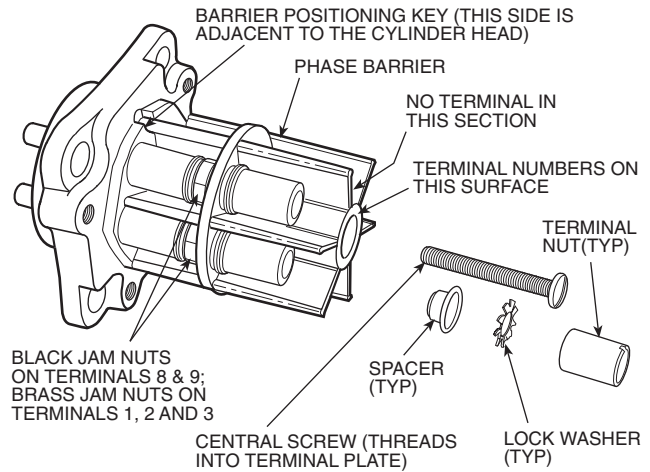

Fig. 18 — Motor End Cover Assembly



ACROSS-THE-LINE APPLICATION (5 TERMINALS)

Fig. 19 — Terminal Plate Assembly

7. Remove bolts holding counterweights and eccentric strap side shields to eccentric shaft. Remove eccentric strap side shields. Remove pump end counterweight through pump end bearing head opening. Motor end counterweight will remain on eccentric shaft until shaft is removed.
8. Pull eccentric shaft or crankshaft out through pump end opening. Guide eccentric straps from eccentric shaft during removal process. Rotate shaft and tap it lightly to prevent straps from jamming.
9. Remove eccentric straps or connecting rods and pistons through bottom cover plate opening.
10. Disassemble connecting rods or eccentric straps from pistons by removing lock ring(s) and piston pins. Remove oil and compression rings from piston. *Keep each piston assembly together for proper reassembly.*

Check all parts for wear and tolerances shown in Table 6. Check crankshaft (eccentric shaft) oil passages and clean if clogged.

PUMP END MAIN BEARING — This bearing is a machined part of the new aluminum oil pump and bearing head casting. Disassemble bearing head. If bearing is scored or worn, replace complete bearing head.

CRANKCASE AND MOTOR END MAIN BEARINGS — These bearings are not field replaceable. If bearings are worn or damaged, replace compressor.

Compressor Running Gear Replacement

CRANKSHAFT — Install crankshaft through pump end, carefully guiding it through main bearings. Replace rotor. Attach equalizer tube assembly to motor end of shaft.

Eccentric shafts must be installed after piston assemblies. Place motor end counterweight on shaft before inserting shaft into compressor. See Piston Assembly Replacement.

PISTON ASSEMBLY — Attach connecting rods or eccentric straps to pistons with piston pins and lock in place with piston pin lock rings. Place lock rings with gap on the side. They should be tight enough so they cannot be rotated by finger pressure.

RINGS

1. Check ring gap by inserting each ring separately in cylinder, approximately $\frac{3}{8}$ in. from top. Ring gap should be between .013 and .005 inch.
2. Install compression rings in top piston grooves with side marked "Top" toward piston head. Install oil ring below compression ring with notched end on bottom. Stagger ring gaps around piston.
3. Measure side clearance between ring and piston (Table 6). Check for free action.

PISTON ASSEMBLY REPLACEMENT

Compressors Using Crankshafts — Install connecting rod and piston assemblies into cylinders. Place chamfered sides of connecting rods against radius of crankpins. Install connecting rod caps to matching connecting rods through bottom of crankcase. Be sure chamfered sides of caps are against radius of crankpins. Caps are locked in place with cap screws. Use 8 to 10 lb-ft to tighten cap screws.

Compressors Using Eccentric Shafts — Install eccentric strap and piston assemblies into cylinders. Install eccentric shaft through pump end, carefully guiding it through eccentric straps and main bearings. Install pump end counterweight to eccentric shaft and replace eccentric strap side shields.

Turn crankshaft or eccentric shaft to be sure there is no binding between bearing surfaces and journals. Replace oil screen, bottom cover plate, valve plates and cylinder heads.

COMPRESSOR MOTOR BURNOUT

DANGER

Do not attempt start-up with terminal cover removed. Bodily injury or death may result from explosion and/or fire if power is supplied to compressor with the terminal cover removed or unsecured. See warning label on terminal cover.

Clean-Up Procedure — If a hermetic motor burns out, the stator winding decomposes, forming carbon, water and acid which contaminate refrigerant systems. Remove these contaminants from system to prevent repeat motor failures.

1. Close compressor suction and discharge service valves, and bleed refrigerant from compressor. Save remaining refrigerant in system.
2. Check control box for welded contactor contacts, welded overload contacts or burned out heater elements. Check terminal plate for burned or damaged terminals, insulation, and shorted or grounded terminals. Repair or replace where necessary.
3. Remove suction and discharge shutoff valve bolts and all other connections to damaged compressor. Remove damaged compressor and replace with new compressor. Replace liquid line filter drier with a drier of one size larger.
4. Purge new compressor. Triple-evacuate, using the following procedure:
 - a. Evacuate to 5000 microns.
 - b. Break vacuum with system refrigerant. Pressurize to 15 psig. Wait 20 minutes to remove moisture.
 - c. Re-evacuate to 5000 microns.
 - d. Repeat Step b.
 - e. Evacuate to 1000 microns or below if possible.
5. Place compressor in operation. After 2 to 4 hours of operation, check compressor oil for signs of discoloration and/or acidity. If oil shows signs of contamination, replace oil charge, filter driers, and clean suction strainer with solvent. Repeat this procedure until oil stays clean and acid free for 48 hours of operation.

TROUBLESHOOTING

⚠ WARNING

Read Safety Considerations on page 1 before proceeding with troubleshooting.

PROBLEM	CAUSE	REMEDY
Compressor does not run.	Main power line open.	Replace fuse or reset circuit breaker.
	Safety thermostat tripped.	Reset thermostat.
	Condenser water pump not running — power off.	Restart.
	Pump binding.	Free pump.
	Incorrect wiring.	Rewire.
	Motor burned out.	Replace.
	Control stuck open.	Replace control.
	Loose terminal connection.	Check connections.
	Improperly wired controls.	Check wiring and rewire.
	Low line voltage.	Check line voltage — determine location of voltage drop.
	Compressor motor defective.	Check motor winding for open or short. Replace compressor if necessary.
	Seized compressor.	Replace compressor.
Compressor cycles on low-pressure control.	Low-pressure control erratic in action.	Raise differential setting, check capillary for pinches, replace control.
	Suction shutoff valve partially closed.	Open valve.
	Low refrigerant charge.	Add refrigerant.
	Plugged suction strainer.	Clean strainer.
	Defective TXV.	Replace.
Compressor cycles on high-pressure control.	High-pressure control erratic in action.	Check capillary tube for pinches. Set control as required.
	Discharge valve partially closed.	Open valve.
	Air in system.	Purge.
	Condenser scaled (or airflow restricted).	Clean condenser.
	Receiver not properly vented, refrigerant backs up into evap condenser.	Repipe as required.
	Condenser water pump or fans not operating.	Start pump or fans.
Insufficient capacity.	Refrigerant overcharge.	Purge.
	Low refrigerant charge.	Add refrigerant.
	Control set too high.	Reset control.
	Expansion valve plugged.	Clean or replace.
	Inefficient compressor.	Check valves and pistons.
	Expansion valve setting too high.	Lower setting.
	Iced or dirty evaporator.	Defrost or clean.
	Evaporator too small.	Add surface or replace.
	Condensing unit too small.	Add unit or replace.
	Expansion valve too small.	Raise suction pressure with larger valve.
Unit operates long or continuously.	Restricted or small gas lines.	Clear restriction or increase line size.
	Low refrigerant charge.	Add refrigerant.
	Control contacts fused.	Replace control.
	Air in system.	Purge.
	Partially plugged or plugged expansion valve or strainer.	Clean or replace.
	Defective insulation.	Replace or repair.
	Service load.	Keep doors and windows closed.
	Inefficient compressor.	Check valves.
	Condenser scaled.	Clean condenser.
	Restricted evaporator air.	Defrost coil, clean filters and ductwork.

LEGEND

TXV — Thermostatic Expansion Valve

PROBLEM	CAUSE	REMEDY
System noises.	Piping vibration.	Support piping as required, check for loose pipe connectors.
	Expansion valve hissing.	Add refrigerant, check for plugged liquid line strainer.
	Compressor noisy.	Check valve plates for valve noise, replace compressor (worn bearings), check for loose compressor holddown bolts.
	Insufficient compressor oil.	Add oil.
Compressor loses oil.	Leak in system.	Repair leak.
	Plugged or stuck compressor oil return check valve.	Repair or replace.
	Oil trapping in line.	Check piping for oil traps.
	Crankcase heaters not energized during shutdown.	Replace heaters.
Frosted suction line.	Expansion valve admitting excess refrigerant.	Adjust expansion valve.
Hot liquid line.	Shortage of refrigerant.	Repair leak and recharge.
Frosted liquid line.	Receiver shutoff valve partially closed or restricted.	Open valve or remove restriction.
	Restricted catchall.	Replace.
	Restricted strainer drier.	Replace.
Frosted expansion valve.	Ice plugging TXV orifice.	Apply hot wet cloth to TXV.
	Moisture indicated by increase in suction pressure.	Install drier.
	Plugged TXV strainer.	Clean strainer or replace TXV.

LEGEND

TXV — Thermostatic Expansion Valve

