

SPECIFICATIONS

SM-97

SM-97

Model no.	3A-450 38640-0450	3A-750 38640-0750	3A-1000 38640-1000
Free Speed (RPM)	450	750	1000
Min. Torque Ft-Lb	3	3	3
Max. Torque Ft-Lb	18	12	10
Air Pressure psi		90	
Air Inlet		3/8" NPT	
Hose		3/8" I.D.	
Air Flow @Free Speed		32 CFM	
Spindle		1/2" Dia. with 2 spots	



Torq-Air-Matic

Model 3A-450 (450RPM)

Model 3A-750 (750RPM)

Model 3A-1000 (1000RPM)



OPERATING INSTRUCTIONS & SERVICE MANUAL

TO REDUCE THE RISK OF INJURY, USER MUST READ AND UNDERSTAND OPERATOR'S MANUAL.

Thomas C. Wilson, Inc.

21-11 44th Avenue, Long Island City, New York 11101
Tel: (718)729-3360 Fax: (718)361-2872 <http://www.tcwilson.com>
Email: tcwilson@tcwilson.com

Thomas C. Wilson, Inc.

21-11 44th Avenue, Long Island City, New York 11101
Tel: (718)729-3360 Fax: (718)361-2872 <http://www.tcwilson.com>
Email: tcwilson@tcwilson.com

 <p>WARNING!</p> <p>READ AND UNDERSTAND ALL INSTRUCTIONS Failure to follow all instructions listed below, may result in accident, fire and/or personal injury. SAVE THESE INSTRUCTIONS</p>
--

1. Do not allow corrosive gases or foreign material to enter the unit. Moisture, oil-based contaminants, or other liquids must be filtered out.
2. Eye protection is always required when running motor.
3. Hearing protection is recommended when in close proximity to all operating air motors.
4. Dust mask, non-skid safety shoes, hard hat, gloves and other personal safety equipment must be used.
5. Stay alert, watch what you are doing, and use common sense when operating a power tool.
6. Dress properly. Do not wear loose clothing or jewelry.
7. Keep your work area clean and well lit.
8. Do not operate power tools in explosive atmospheres, such as in the presence of flammable liquids, gases, or dust.
9. Disconnect the tool from the air supply before installing, making any adjustment, changing accessories, servicing or storing tool.

PROBLEM	CAUSE & SOLUTION
Torque control will not release at torque setting	<ol style="list-style-type: none"> 1. Broken latch release pawl —Replace—see pg. 8, (Pc. #36, pg. 11). 2. Broken torque spring —Replace—see pg. 8, (Pc. #5, pg. 11). 3. Broken latch —Replace—see pg. 8, (Pc. #34, pg. 11). 4. Broken or excessive wear on tips of all pawls —Replace—see pg8(Pc29,36,40&42, pg.11). 5. Broken spring ends or anchor pins of latch pawls and reverse pawl —Replace—see pg.8, (Springs & pins, pg. 11). 6. Reaction member seized to int. gear assembly —Consult factory 7. Broken or short roll pin stop on reaction member. Check for scoring on stop plate section of handle connector —Replace—see pg. 7, (Pc. #32, pg. 11). 8. Ball retainer has broken or lost any balls. Check correct assembly of retainers. —Replace—see pg. 9, (Pc. #43, pg. 11).
Torque control will not relatch in reverse	<ol style="list-style-type: none"> 1. Broken latch or latch spring —Replace—see pg. 8, (Pc. #28,34, pg. 11). 2. Broken reverse pawls, springs or anchor pin —Replace—see pg.8 (Pc#39,40,41,42, pg.11). 3. Slot radii on internal gear oversized/gouged —Replace internal gear (Pc. #10, pg. 11) 4. Insufficient torque on drive spindle end —See note on pg.5. Hold spindle end in vise and manually turn TAM ccw; should relatch. 5. Excessive burrs or wear on internal gears preventing free rotation —Debur/replace—see pg. 7,(Pc. #10, pg. 11).

Caution: Disassembly or reassembly of torque control unit must be performed by qualified personnel. It is advisable to return torque control units to the factory or consult the factory for necessary repair.

PROBLEM	CAUSE & REMEDY
Motor will not run.	<ol style="list-style-type: none"> 1. Inefficient air supply —Check 90 psi and 32 CFM air supply. 2. Clogged air inlet screen —Replace-see pg.6(pc #75, pg.13). 3. Broken or severely worn rotor blades —Replace-see pg.6(pc #69, pg.13). 4. Rust due to improper storage of tool —Disassemble and clean– Refer to Dis-assembly procedure. 5. Broken throttle valve pin or lever —Replace-see pg.6(pc. #78/80, pg. 13).
Motor will not reach RPM.	<ol style="list-style-type: none"> 1. Insufficient air volume —Check 32 CFM supply. 2. Dirty air inlet screen —Clean –see pg. 6 (pc.#75, pg.13). 3. Worn rotor blades —Replace-see pg.6(pc #69, pg.13). 4. Air supply hose chocked or too small —See Operating Procedure recom-mended hose.
Motor stalls at high torque	<ol style="list-style-type: none"> 1. Insufficient air pressure —Check 90 psi supply 2. Dirty air inlet screen —Clean –see pg. 6 (pc.#75, pg.13). 3. Rotor blades worn, chipped or broken —Replace-see pg.6(pc #69, pg.13).
Motor fails to stop	<ol style="list-style-type: none"> 1. Broken throttle valve spring —Replace-see pg.6(pc #76, pg.13). 2. Valve ball does not seal —Replace or rework valve seat-Refer to pg. 6 (pc.#77, pg.13)

Improperly rolled joints create additional expense to correct, whether they are under-rolled and can be corrected merely by rerolling, or over-rolled and require removal and replacement. The optimal joint is one that develops a leak tight joint with adequate strength for the service intended with the minimum amount of cold working or reduction of the tube wall. Experience indicates that joints of this type are obtainable with non-ferrous tubes in surface condensers by expanding to a wall reduction of 3% to 4% after metal to metal contact of the tube O.D. with the tube sheet hole. Steel tubes in heat exchangers may require wall reductions of 5% to 10%; soft copper and aluminum tubes in heat exchangers also require larger wall reductions in the area of 8% to 12%. Boiler tubes requiring development of optimum joint strength require wall reductions of 12% to 14%. A typical example of the application of this method is indicated for a 3/4" x 18 ga. tube in a condenser.

Tube Expansion Calculations	
Tube Sheet Hole Dia.	.760
- Tube O.D.	-.750
= Clearance	=.010
+ Tube I.D.	+.652
=I.D. @ Metal to Metal	=.662
+4%Reduction (.049x.04x2)	+.004
=Expanded I.D.	=.666

OPERATION

RECOMMENDED OPERATING AIR PRESSURE 90 PSI

1. Make sure there is an adequate supply of clean air of 90 psi lubricated with light machine oil of SAE 10 viscosity. This should be done before all long runs of tube expanding and after every four hours of continuous use unless an air line lubricator of ample capacity is used. SEE 'LUBRICATION' SECTION BELOW.

OPERATION (Cont')

SM-97

2. Loosen the four hexagon socket set screws at rear of control housing 1/2 to 3/4 turn and rotate index mark on housing to desired torque. Tighten all four screws. See paragraph entitled "Calculating the Expansion Required".

To avoid the possibility of over-rolling, it is best to make the trial setting low and work up to the desired setting, a record of which should be kept for future use.

3. The clamp-on handle (Part No. 24305) can be swiveled to the position most convenient for the operator. Its use is optional but recommended for any job requiring more than three foot-pounds torque.

4. Always blow out air hose thoroughly before attaching it to throttle valve cap which takes the 3/8" pipe coupling of 3/8" hose assembly supplied (No. 50007). Always use a 3/8" I.D. or larger air line when maximum power is desired and be sure that air pressure at the tool is at least 90 psi gauge.

5. The exhaust deflector can be rotated to deflect exhaust air in the most convenient direction.

6. Select required snap-on mandrel drive and attach it to tool spindle nose. Be sure to align detents within it with drilled spots on spindle nose. (Instructions for releasing detents are stamped on mandrel drive sleeves.)

7. Adjust Thrust Collar on expander and attach mandrel to snap-on mandrel drive by engaging detent and circular groove on mandrel's square shank.



PARTS LIST (Cont')

SM-97

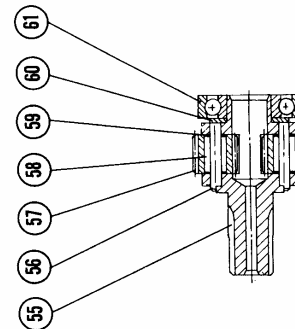
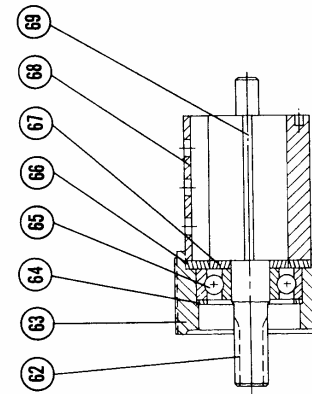
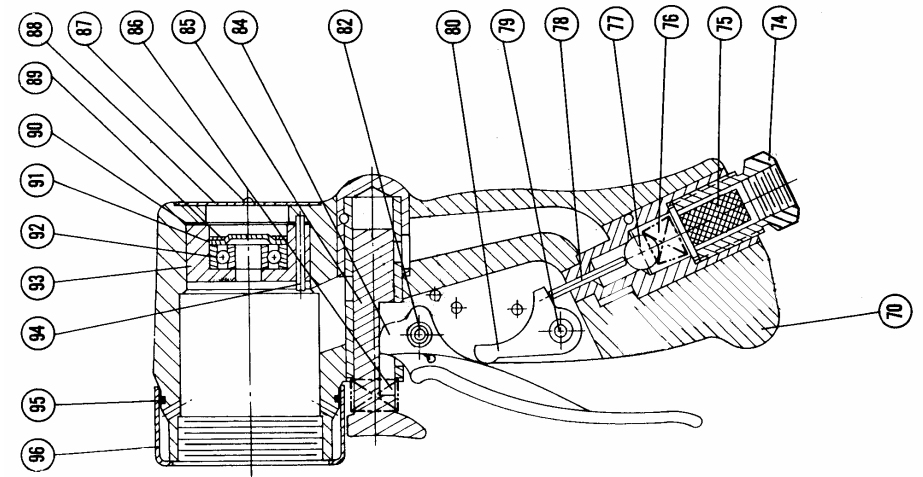

PARTS LIST (Cont')

SM-97

Key	Description	3A-1000	3A-750	3A-450
	Motor & Spindle Assembly	38649-1000	38649-0750	38649-0450
	Intermed Spindle Ass'y (Keys 55 thru 61)	51143	51142	51141
55	Intermediate Spindle	51123	51122	51121
56	Planet Pin (2)	24512	24512	24512
57	Planet Gear (2)	51102	24321	51105
58	Needle Roller (2 Sets)	24354	24354	24354
59	Roller retainer (2 Sets)	24355	24355	24355
60	Retainer Washer	51118	51118	51118
61	Rear Drive Ball Bearing	24525	24525	24525
	Air Motor Assembly (Keys 62 thru 69)	53581-0001	53581-0002	53581-0003
62	Rotor	51133	51132	51131
63	Adapter Ring	52497	52497	52497
64	Bearing Separator	51191	51191	51191
65	Front Motor Bearing	51361	51361	51361
66	Front Plate	50809	50809	50809
67	Front Bearing Spacer	51135	51135	51135
68	Cylinder	51225	51225	51225
69	Rotor Blade (Set of 4)	51139	51139	51139
	Motor Housing Ass'y Key70thru86,90,93&94	53579	53579	53579
70	Motor Housing	53580	53580	53580
74	Throttle Valve Cap	42872	42872	42872
75	Air Screen	51179	51179	51179
76	Throttle Valve Spring	51541	51541	51541
Key	Description	3A-1000	3A-0750	3A-0450
77	Valve Ball	2629	2629	2629
78	Valve Pin	51540	51540	51540
79	Lever Pin	28215	28215	28215
80	Throttle Valve Lever	53501	53501	53501
82	Trigger Pin	28215	28215	28215
84	Throttle Valve trigger	51563	51563	51563
85	Reversing Valve Trigger	51544	51544	51544
86	Trigger Spring	52635	52635	52635
87	Drive Screw (2)	6896	6896	6896
88	Nameplate	38635	38635	38635
89	Retaining Ring	53560	53560	53560
90	Gasket	51229	51229	51229
91	Rear Plug	21994	21994	21994
92	Rear Motor Bearing	21944	21944	21944
93	Rear End Plate	51532	51532	51532
94	Roll Pin	51474	51474	51474
95	Seal Ring	28187	28187	28187
96	Exhaust Muffler Assy	53840	53840	53840
	Dead Handle	24305		
	Hex. Key 5/16	52147		
	Hex. Key 1/8	52144		
	Hex. Key 3/16	51254		

OPERATION (Cont')

SM-97

8. Insert expander in tube as required.

9. Completely depress throttle valve trigger lever to find forward speed. When preset torque has been reached, drive will dis-engage and mandrel will stop rotating; release throttle valve lever when this occurs.

10. Fully squeeze reverse valve trigger into reverse position (depressed). Valve locks in this position and only releases when throttle valve trigger lever is released. Depress throttle valve trigger lever to reverse drive and back expander out of tube.

Note: There must be a positive resistance to turning on the tool spindle of 5-6 inch-pounds in the reverse direction before drive will reengage and set latching pawls for rotation in the forward direction.

11. Measure tube's actual inside diameter. If the amount of expansion is not sufficient, adjust torque control to a slightly higher value and roll the next tube.

12. When desired expansion has been attained, maintain the setting and roll the entire lot. Reroll all trial tubes which were not completely expanded.

13. Always record settings used and tube data such as tube O.D. and gauge with tube sheet thickness for future reference.

LUBRICATION

Amount of oil used will vary with tool usage but daily filling of handle oil reservoir should normally be adequate. Check that a fine mist of oil is always present in the air which passes out through exhaust deflector holes. For continuous and heavy tool usage, it is preferable to use an automatic air line lubricator. For this purpose, the Wilson Air Filter-Lubricator Unit (Cat. #8596 for 3/8" lines) is recommended. This unit combines an automatic lubricator with an efficient air filter.

Caution: To inhibit rust during tool storage be sure a liberal amount of oil has been introduced into valve and air motor. Also be sure operating air moisture content is kept at a minimum. Compressor after coolers, air line traps, water separators and use of rust-inhibiting lubricating oil all help. Thoroughly clean or replace any rusted parts found during service checks.

Air Tools should be handled with reasonable care when servicing. It is important that the correct tools and fixtures are used when servicing this Air Tool. Order replacement parts by part number, model and serial number of tool. To maintain Torq-Air-Matic efficiency, periodic checks should be made of the following:

Rotor Blades - Generally these are the only parts requiring replacement after long service. Always replace the rotor blades in a set of 4 only, whenever they are broken or cylinder edge is gouged, worn uneven or worn down 1/16". This would cause the blade edges to be 1/16" below top of its slot in rotor drum.

Cylinder and Rear End Plate - Replacement is required only if part is broken or rubbing surfaces are gouged.

Ball Bearing - normally these ball bearings should not require additional lubrication during tool life. However, whenever tube roller is disassembled for servicing, the motor ball bearings should be lubricated with light oil (SAE #10) while the drive ball bearings should receive a small amount of bearing grease. All ball bearings should turn smoothly and freely with no noticeable looseness. There should be a snub fit with no shake both in their housings and on their shafts. However, the front motor ball bearing is a mild press fit on its rotor shaft.

Note: Dirty or gummed up ball bearings should be cleaned in kerosene and flushed with clean light oil (SAE No. 10). DO NOT USE AN AIR BLAST. After flushing, re-lubricate as specified. Be sure both plastic seals are properly replaced on front drive ball bearing.

Intermediate Spindle Assembly and Drive Spindle Assembly - Do not disassemble planet gears from their spindles unless the gears do not move freely about their planet pins. Be careful not to lose any one of the nine needle rollers assembled within each planet gear. Lubricate planet gear and needle rollers with a good bearing grease only.

Caution: Note position of planet pin milled step in relation to steel retaining ring or turned step on drive spindle on assembly drawing before reassembling either spindle.

Air Screen - Throttle valve air screen assembly should be cleaned by reverse flushing when necessary. Before reassembly note on drawing that air screen cylinder is assembled within the throttle valve cap. Also when reassembling be sure small end of conical throttle valve spring rests against the 3/8" diameter hardened steel ball. Be sure air screen flange comes to rest correctly within its counter-bore in steel seat insert.

PARTS LIST (Cont')

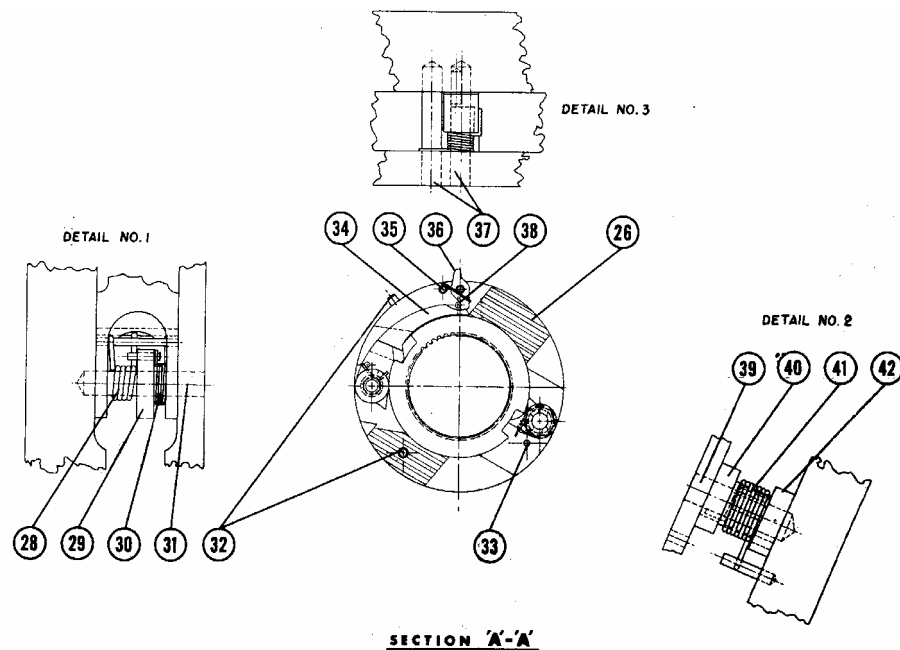
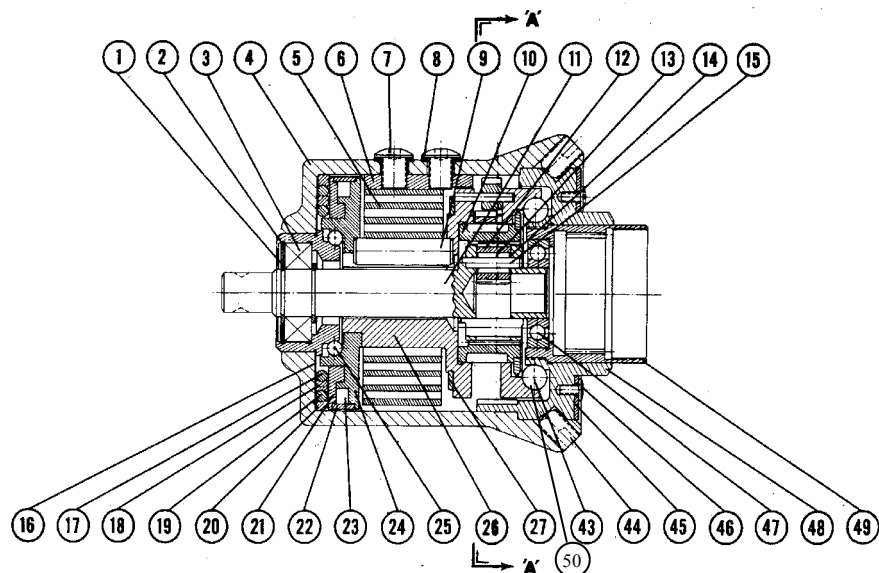

PARTS LIST

SM-97

Key	Description	3A-1000	3A-750	3A-450
	Torque Control Ass'y	38641-1000	38641-0750	38641-0450
1	Retainer (2)	24317		
2	Spirolox Ring	34262		
3	Front Bearing	28069		
4	Control Housing Ass'y	40024-1000	40024-0750	40024-0450
5	Main Spring	24307		
6	Main Spring Anchor	24318		
7	Button Head Screw (2)	24319		
8	Lock Washer (2)	28106		
9	Main Spring Pin	24313		
10	Internal Gear	38658	38657	38658
11	Drive Spindle	38664	38664	38661
12	Planet Gear (3)	24504	24364	24321
13	Needle Roller (3 Sets)	24354		
14	Roller Retainer (3Sets)	24355		
15	Planet Pin (3)	24314		
16	Snubber Shim (0-3)	40561		
17	O-Ring	28100		
18	Quad-Ring	28102		
19	O-Ring	28101		
20	Quad-Ring	28103		
21	Brake Shoe	38643		
22	Brake Rolls Retainer	24311		
23	Brake Roll (3)	24324		
24	Bearing Race Brake-Cam	38644		
25	Front Ball Retainer	28088		

Key	Description	3A-1000	3A-0750	3A-0450
26	Reaction Member	24907		
27	Retainer	28096		
28	Latch Spring	24913		
29	Latch Return Pawl	24911		
30	Return Pawl Spring	24912		
31	Latch Pin	24333		
32	Roll Pin (2)	25177		
33	Roll Pin	24908		
34	Latch	24910		
35	Latch Release Spring	24331		
36	Latch Release Pawl	24323		
37	Latch Release Pin (2)	24330		
38	Dowel Pin	24298		
39	Reverse Pawl Pin	24328		
40	Tongued ReversePawl	38665	38665	38665
41	Reverse Pawl Spring	24914		
42	Grooved ReversePawl	24909		
43	Retainer	28067-0001		
44	Set Screw (4)	20480		
45	Index Plate	38653	40014	38652
46	Screw (2)	24320		
47	Rear Bearing	51194		
48	Handle Connector	38651		
49	Internal Gear	38654	38653	38655
50	Balls (13)	21941		

DISASSEMBLY

SM-97

The following instructions should be studied carefully before attempting disassembly of Model '3A' Torq-Air-Matic. In most cases, the major difficulty encountered has been caused by improper disassembly and reassembly procedures.

Torque control disassembly procedure

If air motor has been operating properly, do not remove it from torque control section at this time, but proceed as outlined. The steps to be followed have been grouped. Steps within a group may be performed in any sequence. The groups, however, cannot and must not be performed out of sequence. All steps within a group must be completed before proceeding to the following group. Refer to assembly drawing on Page 11.

Group no.1

- (A) Unscrew and remove both spring anchor button head screws. Use 3/16" hexagon key supplied.
- (B) (B) Unscrew all four torque setting set screws halfway out at rear of control housing. Use 1/8" hexagon key supplied.
- (C) Remove outside bearing shaft retainer ring (Piece No.1).

Group no. 2

- (A) Grasp unit by torque control housing with the 1/2" diameter output spindle uppermost and vertical. Hold it with the motor handle 1/2' to 1" above the work surface.
 - (B) With a soft faced hammer, tap the output spindle gently. The entire internal mechanism will fall free as soon as the reduced diameter portion of output spindle has passed through front ball bearing.
- NOTE: Avoid hitting this bearing or housing.

Group no.3

- (A) Remove inside bearing shaft retainer ring (Pc #1).
- (B) Lift out front ball bearing (Pc #25).
- (C) Lift off front brake shoe (Pc #21).
- (D) Remove 3 brake rolls (Pc #23).
- (E) Lift off brake roll retaining ring (Pc #22).

Group no.4

- (A) The subassembly consisting of reaction member assembly with latch and various pawls, mainspring with its pin and anchor and brake cam may then be lifted up off motor drive spindle assembly.
- (B) When failure is due to a malfunction of torque control unit, the failing parts, usually, can be found easily by observing operations of the various pawls and latch. This can be done by holding subassembly in the hand and applying torque or turning force to internal gear (Pc #10) within reaction member (Pc #26). See Trouble Shooting Chart.

DISASSEMBLY(Cont')

SM-97

NOTE: As machine is being driven in forward direction, a counterclockwise torque is applied to the internal gear, when looking at the open end. This gear is prevented from turning in reaction member by the latch (Pc. #34), which can be released by tripping release pawl (Pc #36) while applying a counterclockwise torque to internal gear, which is then free to continue rotation in that direction. When tool is reversed, a clockwise torque is applied to internal gear which makes one turn only to reengage the main latch (Pc #34).

Group no. 5

If investigation shows that malfunction is due to a broken latch, pawl or spring, they can be replaced in the following manner:

(A) Grasp brake cam (Pc #24) and punch reaction member from it.
NOTE: When replacing this brake cam for reassembly, be sure it is seated squarely and firmly against the shoulder on the reaction member.

Group no.6

(A) Mainspring (Pc #5) with its anchor (Piece No.6) and mainspring pin (Pc #9) can then be removed.

Group no.7

(A) Removal of retaining ring (Pc #27) will permit removal of various pins on which the latch and pawls are pivoted. consisting of reaction with latch and various pawls, its pin and anchor and brake lifted up off motor drive

Air motor disassembly procedure

- (A) Hold Torq-Air-Matic fixed with offset handle upwards.
- (B) Prevent rotation with wrench locked on 2" hexagon located against torque calibrated index plate.
- (C) Tap motor handle with a soft-faced mallet in a counterclockwise direction when viewed from offset handle end.
- (D) Unscrew and remove air motor and offset housing assembly complete.
- (E) Remove intermediate spindle assembly from air motor assembly or from within internal gear.
- (F) Unscrew adapter ring (Pc #63) out of cast aluminum motor housing.
- (G) Rotor with 4 rotor blades, front plate spacer, ball bearing and separator can now be lifted out.

Note: Leave cylinder and assembled rear end plate within motor housing. Refer to assembly drawing on page xx.

REASSEMBLY

SM-97

To reassemble TORQUE CONTROL or AIR MOTOR follow disassembly steps in reverse.

• Torque control special note

On reassembly of ball retainers, small ball retainer (Pc #25) must be assembled with solid part of ball cage facing steel front bearing housing (Pc #4) in aluminum control housing. Large ball retainer (Pc #43) must be assembled with solid part of ball cage facing steel handle connector (Pc #48).

• Air motor special note

Be sure rotor blades are well oiled before replacing them in their rotor slots. Also check that rotor turns very freely after air motor is reassembled and adapter ring is tightened down. Observe extreme care in meshing the rotor pinion and intermediate spindle pinion with their planet gears when reassembling gear housing assembly to air motor.

• Complete torq-air-matic reassembly sequence

Assemble air motor into motor housing, then assemble intermediate spindle assembly to air motor assembly. Next screw intermediate internal gear with attached torque control assembly onto adapter ring. Tighten air motor assembly to torque control assembly. See method of disassembly above. Assure that gears mesh properly before tightening; do not force. Torque unit will screw onto motor assembly easily with proper gear mesh.

Maintenance and Repair tools

4 Oz. Ball Pein Hammer
4 Oz. Soft Faced Hammer (Brass and Plastic Tip)
Set of Screwdrivers: 1/8" w. x 4" lg. blade
1/4" w. x 4" lg. blade
9" Smooth Jaw Adjustable Wrench (With 2" Minimum Opening)
8" Pressure Lock Wrench (vise grip)
Set of Allen Hex. Wrenches (5/64, 3/32, 1/8, 5/32 and 3/16)
9-1/2" Channel Lock Pliers
Long Needle Nose Pliers
Set of Retaining Ring Pliers Waldes No. 2 & No. 4
Set of Machinists long nose punches
(1/16, 3/32, 1/8, 5/32, 3/16 and 1/4)
6-1/2" Half Round Needle File for Deburring
Small Hand Scraper for Deburring
Sheets fine emery cloth for polishing