



Operating Instructions

Single Conveying Units Compressed Air Venturi Type

SSV-05 SSV-05R SSV-052R

Bulletin No.: CV6-600
Part No.: 882.00243.00

Technical Service:
Service Department
Telephone: (800) 423-3183

Edition: 12/05

This operation manual is for*:

(* Please fill in personally)

Serial number: _____

Built in: _____

Date of delivery: _____

Number of delivery: _____

Date of commissioning: _____

Location: _____

Group of machines: _____

The manufacturer retains all rights to change the information in these operating instructions at any time without notice.

We assume no liability for any errors or direct or indirect damage resulting in context with these operating instructions.

Copying, translation or publication in any form except for personal use of purchaser requires approval from the manufacturer.

All rights reserved.

Please note that our address and phone information has changed. Please reference this page for updated contact information.



These manuals are obsolete and are provided only for their technical information, data and capacities. Portions of these manuals detailing procedures or precautions in the operation, inspection, maintenance and repair of the products may be inadequate, inaccurate, and/or incomplete and shouldn't be relied upon. Please contact the ACS Group for more current information about these manuals and their warnings and precautions.

Parts and Service Department

The ACS Customer Service Group will provide your company with genuine OEM quality parts manufactured to engineering design specifications, which will maximize your equipment's performance and efficiency. To assist in expediting your phone or fax order, please have the model and serial number of your unit when you contact us. A customer replacement parts list is included in this manual for your convenience. ACS welcomes inquiries on all your parts needs and is dedicated to providing excellent customer service.

For immediate assistance, please contact:

- North, Central and South America, 8am – 5pm CST +1 (800) 483-3919 for drying, conveying, heating and cooling and automation. For size reduction: +1 (800) 229-2919.
North America, emergencies after 5pm CST (847) 439-5855
North America email: acsuscanadacustserv@corpemail.com
- Mexico, Central & South America
Email: acslatinamericacustserv@corpemail.com
- Europe, Middle East & Africa +48 22 390 9720
Email: acseuropecustserv@corpemail.com
- India +91 21 35329112
Email: acsindiacustserv@corpemail.com
- Asia/Australia +86 512 8717 1919
Email: acsasiacustserv@corpemail.com

Sales and Contracting Department

Our products are sold by a worldwide network of independent sales representatives. Contact our Sales Department for the name of the sales representative nearest you.

Let us install your system. The Contract Department offers any or all of these services: project planning; system packages including drawings; equipment, labor, and construction materials; and union or non-union installations.

For assistance with your sales or system contracting needs please Call:

North, Central and South America +1 (262) 641-8600 or +1 (847) 273-7700 Monday–Friday, 8am–5pm CST

Europe/Middle East/Africa +48 22 390 9720

India +91 21 35329112

Asia/Australia +86 512 8717 1919

Facilities:

ACS offers facilities around the world to service you no matter where you are located. For more information, please visit us at www.acscorporate.com

United States:

ACS Schaumburg – Corporate Offices

1100 E. Woodfield Road
Suite 588
Schaumburg, IL 60173
Phone: + 1 847 273 7700
Fax: + 1 847 273 7804

ACS New Berlin – Manufacturing Facility

2900 S. 160th Street
New Berlin, WI 53151
Phone : +1 262 641 8600
Fax: + 1 262 641 8653

Asia/Australia:

ACS Suzhou

109 Xingpu Road SIP
Suzhou, China 215126
Phone: + 86 8717 1919
Fax: +86 512 8717 1916

Europe/Middle East/Africa:

ACS Warsaw

Ul. Działkowa 115
02-234 Warszawa
Phone: + 48 22 390 9720
Fax: +48 22 390 9724

India

ACS India

Gat No. 191/1, Sandbhor Complex
Mhalunge, Chakan, Tal Khed,
Dist. Pune 410501, India
Phone: +91 21 35329112
Fax: + 91 20 40147576

Table of Contents

CHAPTER 1: SAFETY INSTRUCTIONS.....	4
1.1. Warnings and Symbols	5
1.2. Explanations and Information	6
1.3. For Your Safety	7
<i>How to Use this Manual.....</i>	<i>7</i>
<i>Warnings and Precautions.....</i>	<i>7</i>
<i>Maintenance Responsibility.....</i>	<i>8</i>
1.4. For the Safety of the Units	9
CHAPTER 2: INSTALLATION INSTRUCTIONS.....	11
2.1. General Information	11
2.2. Installing the Convey or Hopper.....	12
2.3. Installing the Control and Maintenance Unit	13
2.4. Connecting the Compressed Air Supply	14
2.5. Electrical Connection	15
CHAPTER 3: FUNCTIONAL DESCRIPTION	16
3.1. Method of Functioning	16
3.2. Control and Maintenance Unit	17
CHAPTER 4: SET-UP	18
4.1. Preparations.....	18
4.2. Setting the Mixing Ratio of the Components.....	18
4.3. Basic Setting of the Filling Level in the Conveyor or Hopper.....	19
<i>Fine Adjustment of the Filling Level in the Convey or Hopper.....</i>	<i>20</i>
CHAPTER 5: MAINTENANCE.....	21
5.1. Maintenance Intervals.....	22
5.2. Cleaning/Replacing the Filter Cartridge	23
<i>Disassembly.....</i>	<i>24</i>
<i>Assembly.....</i>	<i>24</i>
5.3. Adjusting the Level Probe	24
5.4. Troubleshooting	25
CHAPTER 6: TECHNICAL DATA.....	27
6.1. Dimension Sheet	28
6.2. Spare Parts Lists	31
6.3. Quick Start Guide –XSV Loader.....	34
6.4. Technical Assistance.....	36

Chapter 1: Safety Instructions



These safety instructions apply to anyone near the equipment operation.

Please inform everyone near the operating equipment about the direct and indirect hazards associated with the equipment.

These operating instructions are to be used by everyone who is assigned activities connected with the equipment.

Knowledge of the English language is required.

Make sure that all operating personnel are familiar with the operating instructions and the function of the equipment.

1-1 Warnings and Symbols

The following warnings and symbols are used in these operating instructions.



This symbol indicates **DANGER!** Death or serious injury is possible if the corresponding instructions, regulations or warnings are not observed.



This symbol indicates that serious injury is possible if the corresponding instructions, regulations or warnings are not observed.



This symbol indicates that extensive damage to equipment is possible if the corresponding instructions, regulations or warnings are not observed.



This symbol indicates information that is necessary for becoming familiar with the equipment, i.e. technical correlations.



This symbol indicates that a technical term is explained at this point.

1-2 Explanations and Information

Various terms and designations are used frequently in these operating instructions to ensure clarity. Therefore, please note that the terms used in the text are defined as follows:

- **Equipment**

Equipment can mean an individual unit, a machine, or an installation.

- **Operating Personnel**

Operating personnel are individuals who are responsible for operating the equipment. All personnel engaged in the use of the machine should become familiar with its operation as described in the manual. Each individual must take responsibility for understanding and following all safety rules. Operating personnel should be at least 16 years old.

- **Operator**

The operator of the equipment (production manager, foreman, etc.) is the person responsible for all production sequences. The operator instructs the operating personnel on what should be done.

- **Operating Instructions**

The plant operating instructions describe the interaction of the equipment, production sequences or methods. The plant operating instructions must be compiled by the operator of the equipment.

- **Equipment Foreman**

When several operating personnel work on one machine, the equipment foreman arranges the order. The equipment foreman must be appointed by the operator.

- **Trained Personnel**

Trained personnel are persons who, due to their training, are authorized to perform the required work.

1-3 For Your Safety

How to Use This Manual

- Please read this manual carefully before initial operation. Understanding the instructions and equipment will help to avoid injuries as well as damage to equipment. If you have questions, contact the manufacturer.
- The operators of this unit must be at least 16 years old.
- Store this manual near the site of the machine so that it is readily available to the operators. Faulty operation may lead to accidents!
- Note that, for reasons of brevity, not every possible case of operation or maintenance can be mentioned in this manual.
- Be aware of all safety instructions and danger signs on the unit. This will avoid injuries and damage to material.
- Prepare precise instructions of the unit using this manual. Faulty operation can lead to accidents!

Warnings and Precautions

- Only **PROPERLY TRAINED** individuals familiar with the information in this manual should use this equipment.
- Proper clothing should be worn at all times in order to avoid injuries.
- Compare the connected loads to those of the main supply to avoid electrical shock.
- When using lifting gear, pay close attention to the corresponding instructions to avoid accidents.
- Operate this equipment within the local regulations and requirements of the plant.
- **NEVER** modify or alter the unit without the manufacturer's permission.
- If the unit has been switched off for safety reasons, it must be protected from unauthorized use.
- The unit is exclusively intended for conveying plastic granules and regrind. Any other usage is not permitted.
- This unit is not suitable for processing foods.
- Attachments that are not delivered by the manufacturer must be constructed according to the safety standard EN 294.

- Check all lines, hoses, and coupling pieces regularly for leakage and damage. Any errors must be eliminated immediately.
- The unit may only be used if all corresponding components have been properly connected and are in accordance with relevant regulations.
- Observe the safety instructions for the connected units.

Maintenance Responsibility

- Before beginning maintenance work:
 - Assign a supervisor.
 - Inform all other responsible operating personnel.
 - Turn off the main power supply.
 - Set all compressed air lines on the unit at zero pressure.
 - Repair work should **ONLY** be done by qualified personnel.
- **ALWAYS** turn off the main supply for all electrical work to avoid risk of death or injury.
- **NEVER** operate on a unit that is partially disassembled. This can cause serious injuries including amputation and electric shock.
- In case of functional disturbances, switch the unit off **IMMEDIATELY**. Any errors must be eliminated to avoid accidents.

1-4 Unit Safety

- The unit may **ONLY** be used for conveying cylindrical plastic granules and regrind on injection molding machines.
- **NEVER** change the settings unless you are able to foresee the consequences.
- Use **ONLY** original manufacturer parts.
- Follow a regular maintenance schedule.
- Keep records of all maintenance and repair work.
- Be aware that electronic subassemblies may be damaged by static discharge.
- Before initial operation and at regular intervals, check all electrical connections for proper fit.
- **NEVER** modify sensors without knowing their precise functions.
- Make sure all plugs are connected properly.
- Note the carrying capacity of the machine flange.
- Read the operating manuals of the connected units.

Chapter 2: Installation



These installation instructions are intended for people with skills in electrical and mechanical areas due to their training, experience and received instructions.

Personnel using these installation instructions must be educated about regulations for accident prevention, operating conditions and safety regulations. Make sure all personnel are informed accordingly. The installation instructions provided in the corresponding operating instructions apply for all connected equipment.

Follow safety regulations with regard to lifting gear handling.

All installation work must be carried out with the electrical power and compressed air supply **OFF**.



For installation work taking place at heights of over approx. 6 feet, use only ladders or similar equipment and working platforms intended for this purpose. At greater heights, the proper equipment for protection against falling must be worn.

Use only suitable lifting gear, which is in proper working order and load suspension devices with sufficient carrying capacity. Do not stand or work under suspended loads!

Use suitable workshop equipment.



Install the equipment such that all parts are easily accessible; this facilitates maintenance and repair work.

2-1 General Information

Unpack all parts of the single conveyor unit and make sure that every thing is available:

- conveyor hopper with level sensor (1)
- control and maintenance unit (2)
- one venturi assembly (3) ①
- one section of vinyl flexible hose (4) with two hose clamps ②
- compressed-air hose
- operating instructions

① The XSV-05/2R comes with two venturi assemblies.

② The XSV-05/2R comes with two sets of vinyl flexible hose and four hose clamps.

Figure 1: XSV-05 Parts

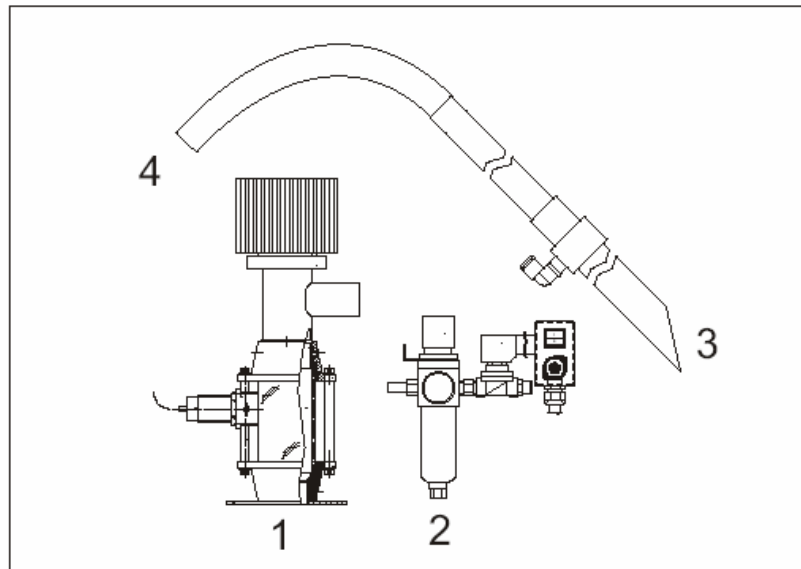

2-2 Installing the Conveyor Hopper

The single conveyor unit is insensitive to shocks and can be installed directly on the processing machine.

Make sure that all connections are tight so that the conveying performance is not impaired. The conveyor hopper is equipped with a universal flange.

- ☑ Depending on the position, drill the holes for fastening the conveyor hopper to the processing machine.
- ☑ Mount the conveyor hopper on the processing machine.
- ☑ Install the vinyl flexible hose on the conveyor hopper and on the venturi assemblies using the hose clamps that are part of the supply.

Note: The hopper should not touch any other component.

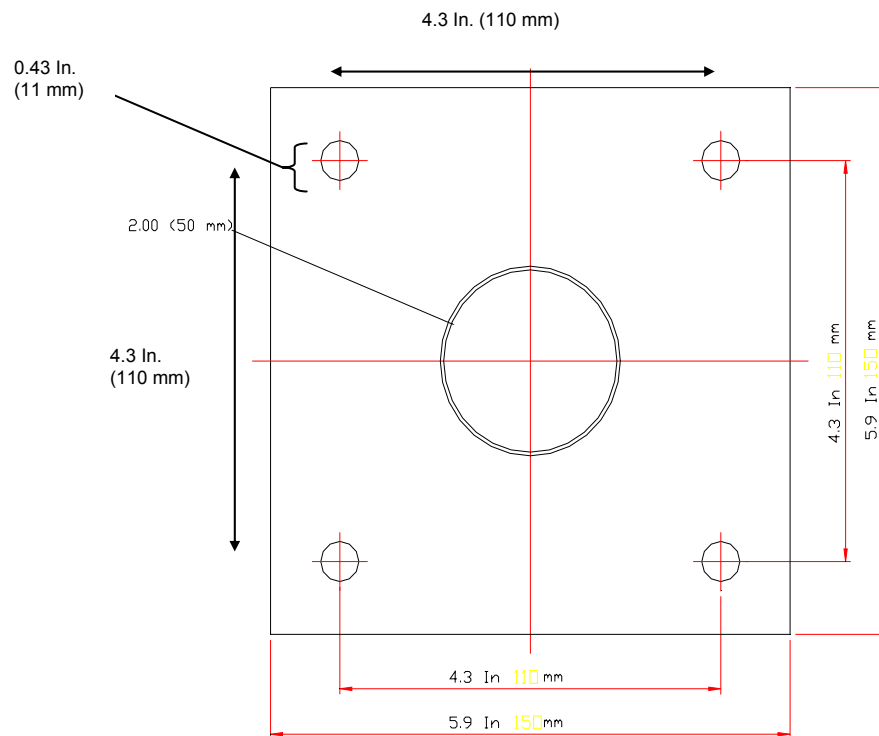

2-3 Installing the Control and Maintenance Unit

Install the control and maintenance unit at a freely accessible site. Check the length of the connection cable and the length of the supplied hoses to the venturi assemblies.

Figure 2: Control and Maintenance Unit

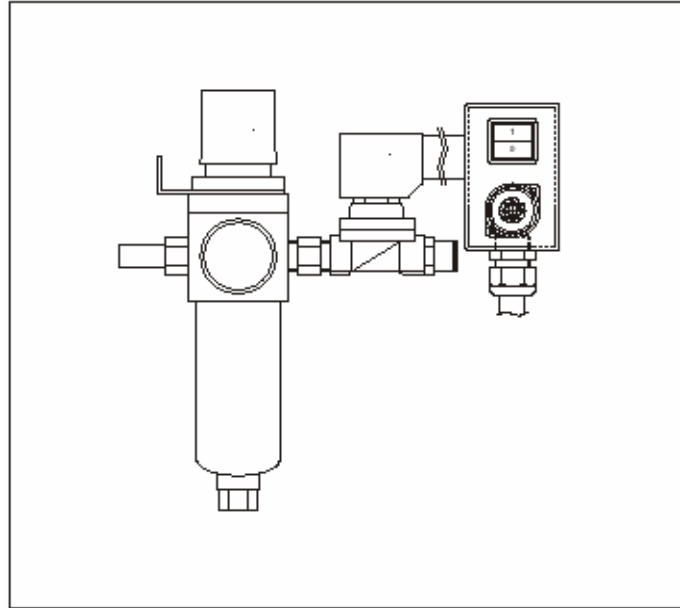

During installation, check the length of the air supply lines.

2-4 Connecting the Compressed Air Supply

Before connecting the compressed air supply, check the following:

- ☑ Check compressed air piping for correct installation and assembly.
- ☑ Check the fittings, length and quality of the hose connections for agreement with requirements.
- ☑ Check all compressed air lines for leakages.

You need a compressed air supply with 70-90 psi (5-6 bar) system pressure.

The air should be free of oil and water.

1. Find the compressed air hose, which has been supplied.
2. Connect it to the venturi assembly and to the control and maintenance unit.
3. The compressed-air hose is firmly pressed into each connecting socket.
4. Connect the control and maintenance unit to the compressed air supply. Max. input pressure 145 psi (10 bar) system pressure.
5. Set the pressure on the pressure reducer at 70-90 psi (5-6 bar).

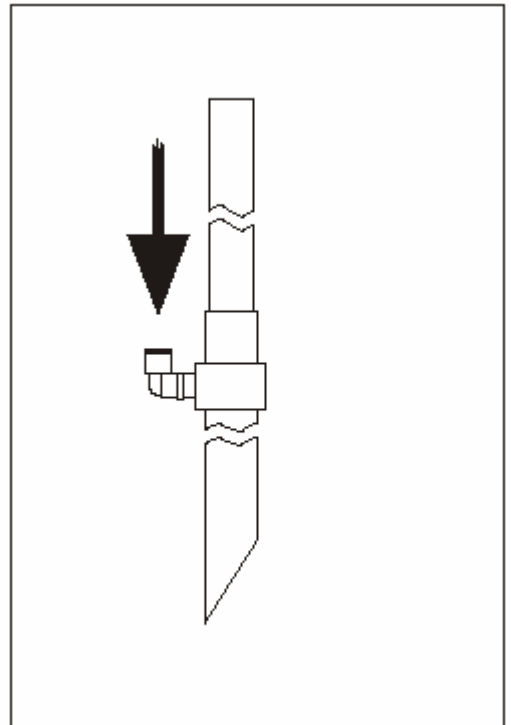

Figure 3: Venturi Assembly



Maximum input pressure: 145 psi (10 bar) system overpressure.

Maximum output pressure: 90 psi (6 bar).

2-5 Electrical Connection



Check with the local electricity board for regulations.

The operating voltage is 110 V, AC, PE, 50/60 Hz. Special voltages available by request.

The connected load is approximately 15 W.

The connection is made using a mains connector. A separate protection of the socket is not necessary.

- Connect the plug of the sensor cable to the control unit.
- Plug the main connector into a corresponding socket.

Chapter 3: Functional Description



This functional description is intended for the operating personnel of the equipment.

General knowledge of operating conveyor units is required.

Ensure in each case that the operating personnel are sufficiently informed.



The XSV-05/R and XSV-05/2R are designed for conveying dust-free plastic granules and regrind material. Only the XSV-05/2R is capable of conveying two materials.

3-1 Method of Functioning

The single conveyor unit works according to the Venturi Principle. An external compressed air supply is needed.

A venturi meter (A) is integrated in the venturi assembly.

The venturi meter aspirates the material in the lower part of the tube (C) and then conveys the material into the conveyor hopper using compressed air in the upper part (B). In the hopper loader, the material is separated from the air.

The filling level of conveyor hopper is monitored and controlled by a level sensor located on the sight glass below the receiver.

Note: The venturi assembly is factory pre-set for optimum conveying. DO NOT ADJUST the venturi assembly.

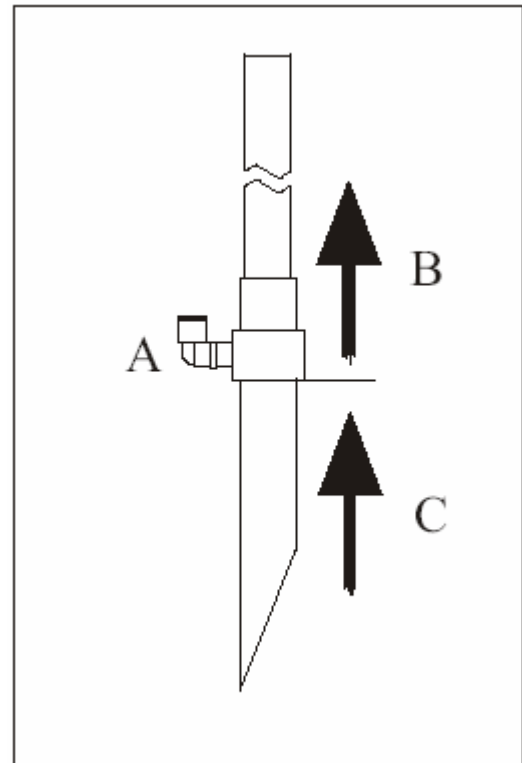
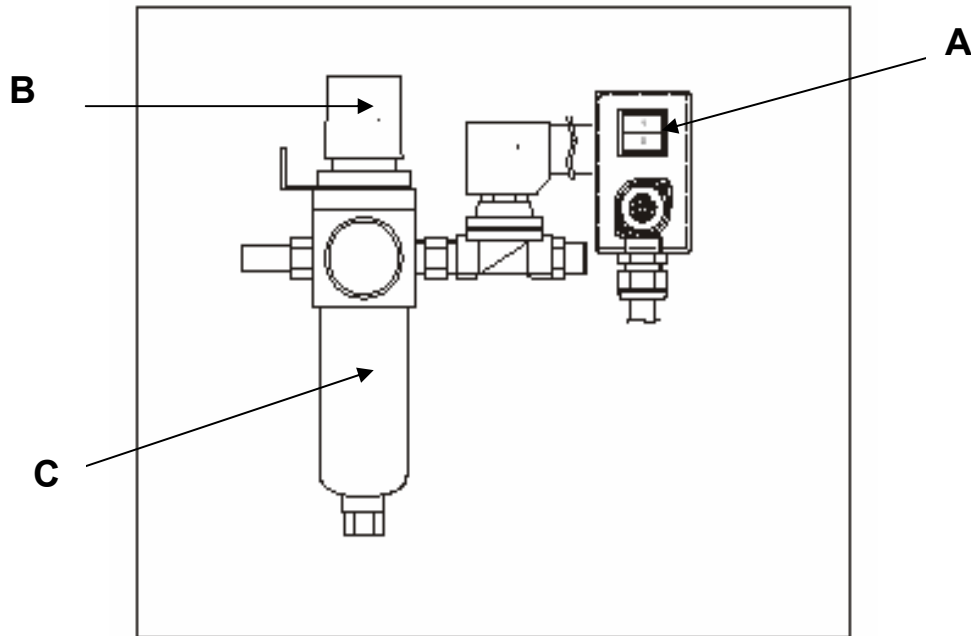

Figure 4: Venturi Assembly

3-2 Control and Maintenance Unit

- A. The unit is switched ON and OFF at the control and maintenance unit.
- B. At the regulator, the operating pressure is adjusted. A water separator is integrated.
- C. Regularly inspect the compressed air filter to make sure that it is clean and functioning properly. Clean or replace this filter as needed. For information, see Section 5-1: Maintenance.

Figure 5: Control and Maintenance Unit



Chapter 4: Setup



This chapter is intended for the operating personnel of the equipment.

General knowledge of operating conveyor units is required. The functional description must be read and understood.

Make sure that in each case the operating personnel are sufficiently informed.

4-1 Preparations

- Check to see if the venturi assembly is inserted in the material to be conveyed.
- Switch the compressed air supply **ON** at the compressed air source.
- Switch the conveyor unit electrical switch **ON** at the control and maintenance unit.

The conveyor unit should now convey until the conveyor hopper is filled up to the level sensor.

4-2 Setting the Mixing Ratio of the Components (XSV-05/2R Units)

The mixing ratio of the components is adjusted at the regulator. By changing the regulator pressure of each material, you will adjust the rate at which each material is conveyed into the conveyor hopper. This will determine the ratio of two materials entering a conveyor hopper.



The adjustment of the regulator will vary according to the material, flow properties, particle size and conveying distance.

4-3 Basic Setting of the Filling Level in the Conveyor Hopper

The filling level in the conveyor hopper is mainly determined by the level sensor.

Figure 6: Conveyor Hopper

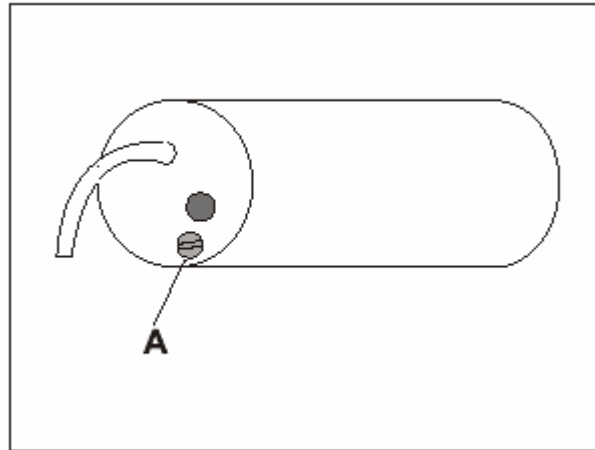

Filling Level Too Low

1. Using a screwdriver, turn the adjustment screw of the level sensor (A) $\frac{1}{4}$ rotation counter-clockwise.
2. Check the filling level during the next conveying procedure.
3. Repeat the process until the desired filling level in the conveyor hopper is reached.

Filling Level Too High

1. Using a screwdriver, turn the adjustment screw (A) of the level sensor $\frac{1}{4}$ rotation clockwise.
2. Check the filling level during the next conveying procedure.
3. Repeat the process until the desired filling level in the conveyor hopper is reached.

Fine Adjustment of the Filling Level in the Conveyor Hopper



Before the fine adjustment, carry through a basic adjustment.

During operation, use a screwdriver to carefully turn the adjustment screw (A) of the level sensor until the desired filling level is reached.



Clockwise rotation makes the filling level fall.
Counter-clockwise rotation makes the filling level rise.

If the filling level in the conveyor hopper cannot be lowered far enough using the level sensor, the pressure on the control and maintenance unit can be reduced gradually.

Chapter 5: Maintenance



This chapter is intended for persons with skills in electrical and mechanical areas due to their training and experience.

Personnel using the information in this chapter must be educated about accident prevention, operating conditions, and safety regulations. Make sure that all personnel are informed accordingly.

For maintenance work taking place at heights of over approx. 6 ft., use only ladders or similar equipment and working platforms intended for this purpose. At greater heights, personnel must wear the proper equipment for protection against falling.

Use only suitable lifting gear, which is in proper working order, and load suspension devices with adequate carrying capacity.

Do not stand or work under suspended loads!

Make sure that the electric motors/switch cabinets are adequately protected against moisture.

Use only proper work shop equipment.

Before starting maintenance work, appoint a supervisor.

Inform the responsible personnel before any maintenance work on the system is started.

Never operate the equipment when it is partially disassembled.

All maintenance and repair work not described in this chapter may only be carried out by service personnel or authorized personnel (appointed by the manufacturer).



Disconnect the equipment from main electrical supply before starting maintenance procedures to ensure that it cannot be switched on unintentionally. Depressurize all compressed air piping of the equipment before starting maintenance work.



Please observe the maintenance intervals.

Before starting maintenance work, clean the equipment of oil, fuel or lubricants.

Ensure that materials and incidentals required for operation as well as spare parts are disposed of properly and in an environmentally sound manner.

Use only original manufacturer spare parts.

Keep record of all maintenance and repair procedures.

5-1 Maintenance Intervals

Daily:	Check the setting of the pressure regulator.
	Empty the water separator.
	Check danger signs on the unit for legibility and completeness.
Monthly:	Clean the cartridge filter and screen (depending on accumulation of dust).
	Blow out the filter from the inside using compressed air.
	Check the electrical connections for proper functioning.
Every 6 months:	Check all electrical and mechanical connections for proper fit.
	Replace filter and screen (depending on accumulation of dust).



The maintenance intervals provided are average values.

The maintenance intervals might be shortened due to your individual process conditions.

5-2 Cleaning/Replacing the Filter Cartridge



Switch the unit **OFF**.

Disconnect the main electrical plug.

Figure 7: XSV-05

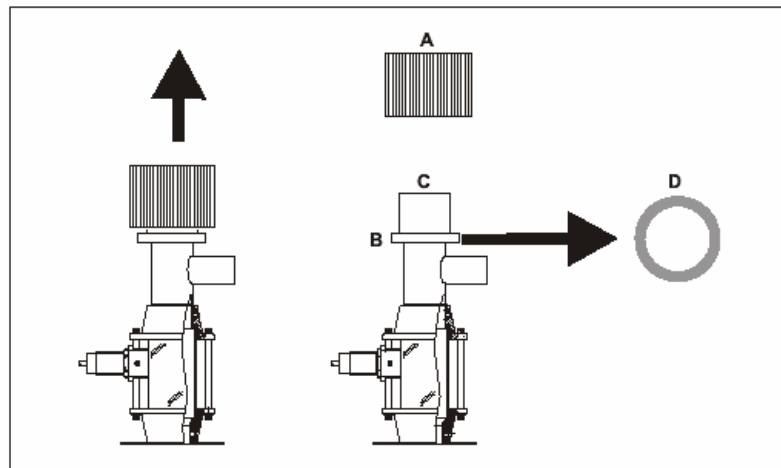
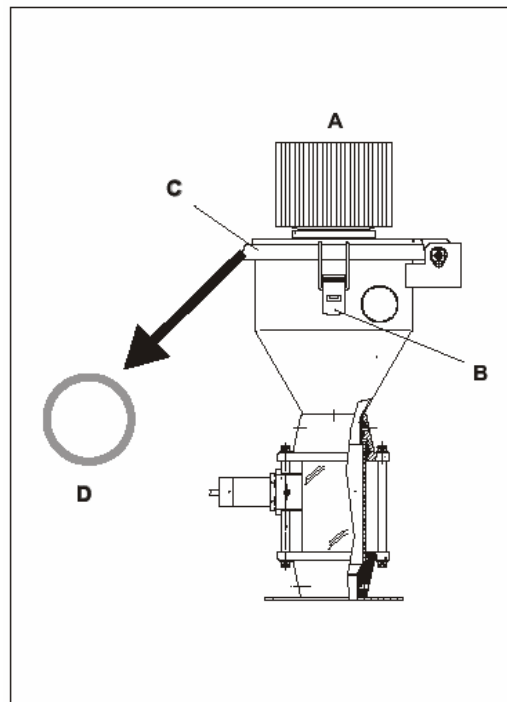

Figure 8: XSV-05/R



Disassembly

1. Remove the filter cartridge (A).
2. Blow out the filter cartridge (A) from the inside out using compressed air or replace the filter.
3. Open the toggle-type fastener (B) and fold the hopper lid upward (C).
4. Check the screen (D) within the lid for material residue. (If you are disassembling the screen for cleaning, draw the screen out of the fit of the gasket ring).
5. Clean the screen (D) using compressed air.
6. Replace the screen and gasket ring as needed if damage you detect damage.

Assembly

1. Assemble the screen and the gasket ring.
2. Check the screen for proper fit.
3. Clean the hopper loader using a vacuum cleaner.
4. Close the hopper lid.
5. Close the toggle-type fastener.
6. Assemble the filter cartridge.

5-3 Adjusting the Level Probe



See Chapter 4: Setup.



Order number level probe: ID 85480

5-4 Troubleshooting

PROBLEM	REMEDY (See Test Steps Below)
The unit is not conveying and is not active.	A, B, G, H
The unit is not conveying; the compressed air valve is switched when the device is switched on.	C, F
The unit is not conveying; the compressed air is flowing.	C, D, E, F, I, J, K
The unit is overfilled.	G, L, M
The unit is not filled properly.	C, D, E, F, I, J, K, L

Test steps:

Make sure the unit is switched **ON**.

Make sure the unit is plugged in and the proper voltage is present.

Make sure sufficient compressed air is available 70-90 psi (5-6 bar).

Make sure the venturi assembly is inserted in the material.

Make sure the compressed air hose is properly connected to the venturi assembly.

Make sure the compressed air hose is properly connected to the maintenance unit.

Make sure the level sensor is properly adjusted.

Make sure the cable of the level sensor is properly connected.

Make sure the filter to is not clogged.

Make sure the screen is not clogged.

Make sure the conveyor vinyl flexible hose is properly connected.

Make sure the compressed air supply is properly adjusted.

-Notes-

Chapter 6: Technical Data

Maximum throughput:	330 lbs/h (149.7 kg/hr)
Weight:	Approx. 6.61 lbs. (3 kg)
Operating voltage:	110 V, AC, PE, 50/60 Hz (standard) Special voltage on request
Connected load:	Approx. 15 W
Total noise level:	< 75 dB (A)
Compressed air supply:	70-90 psi (5-6 bar)
Max. product temperature:	176°F (80 °C)

6-1 Dimension Sheet

XSV-05

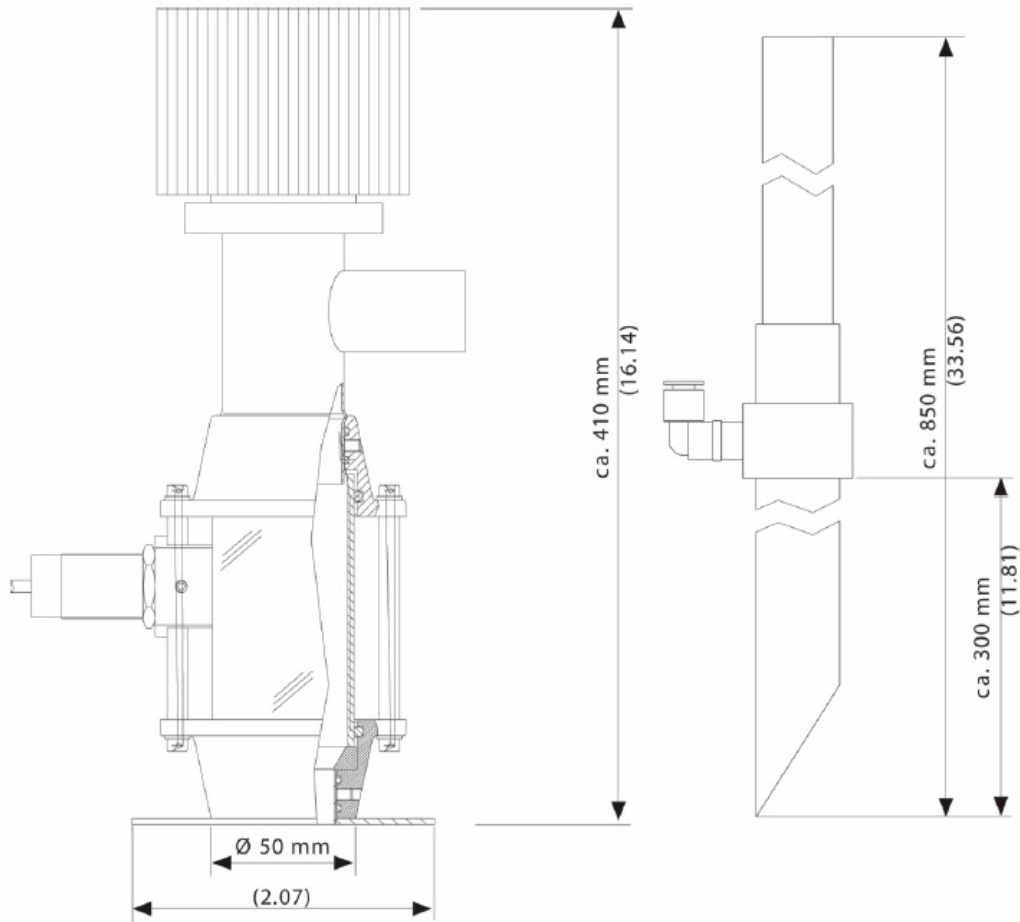

Dimensions and data are not binding. All dimensions are in mm (in.). All data are subject to change.

XSV-05/R

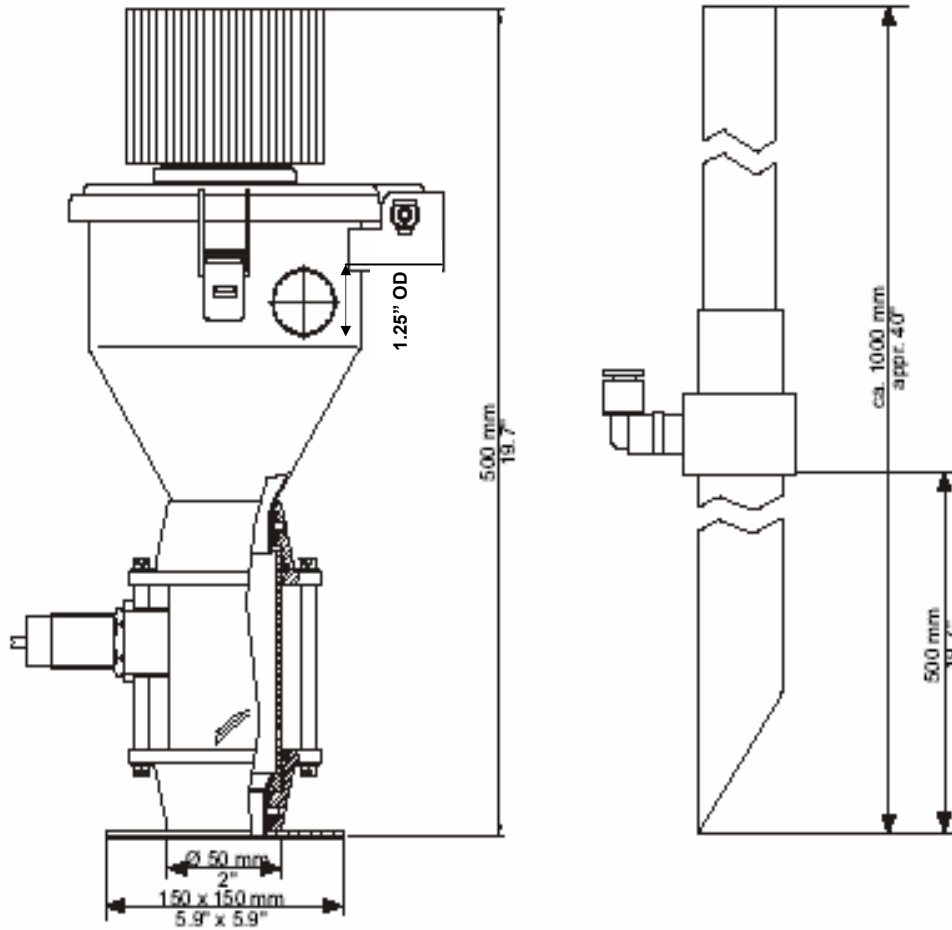

Dimensions and data are not binding. All dimensions are in mm (in.). All data are subject to change.

XSV-05/2R

S

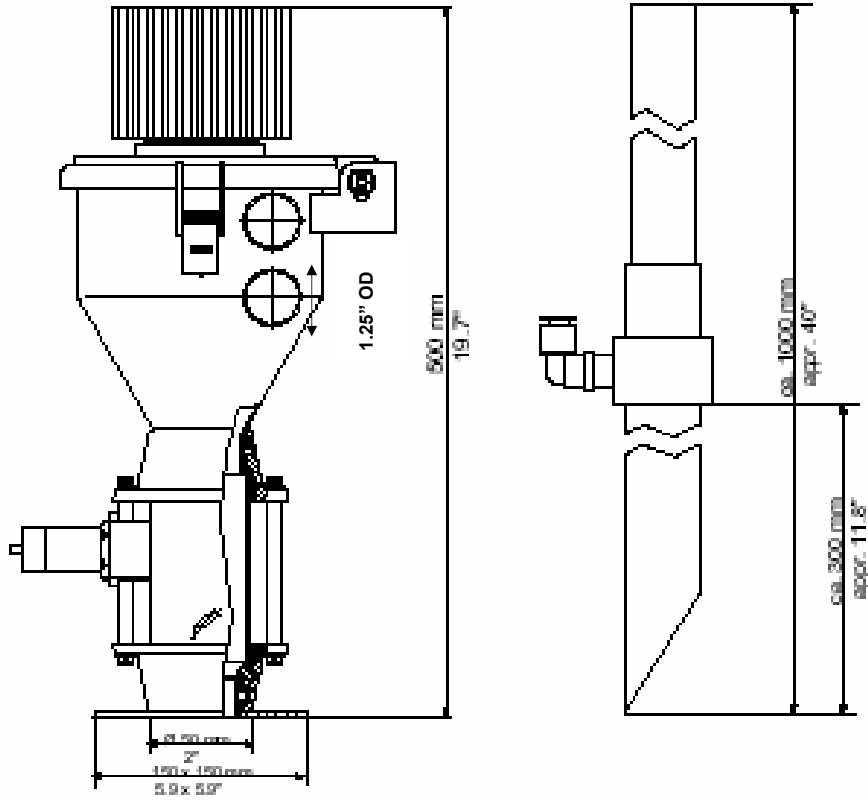

Dimensions and data are not binding. All dimensions are in mm (in.). All data are subject to change.

6-2 Spare Parts Lists

XSV-05

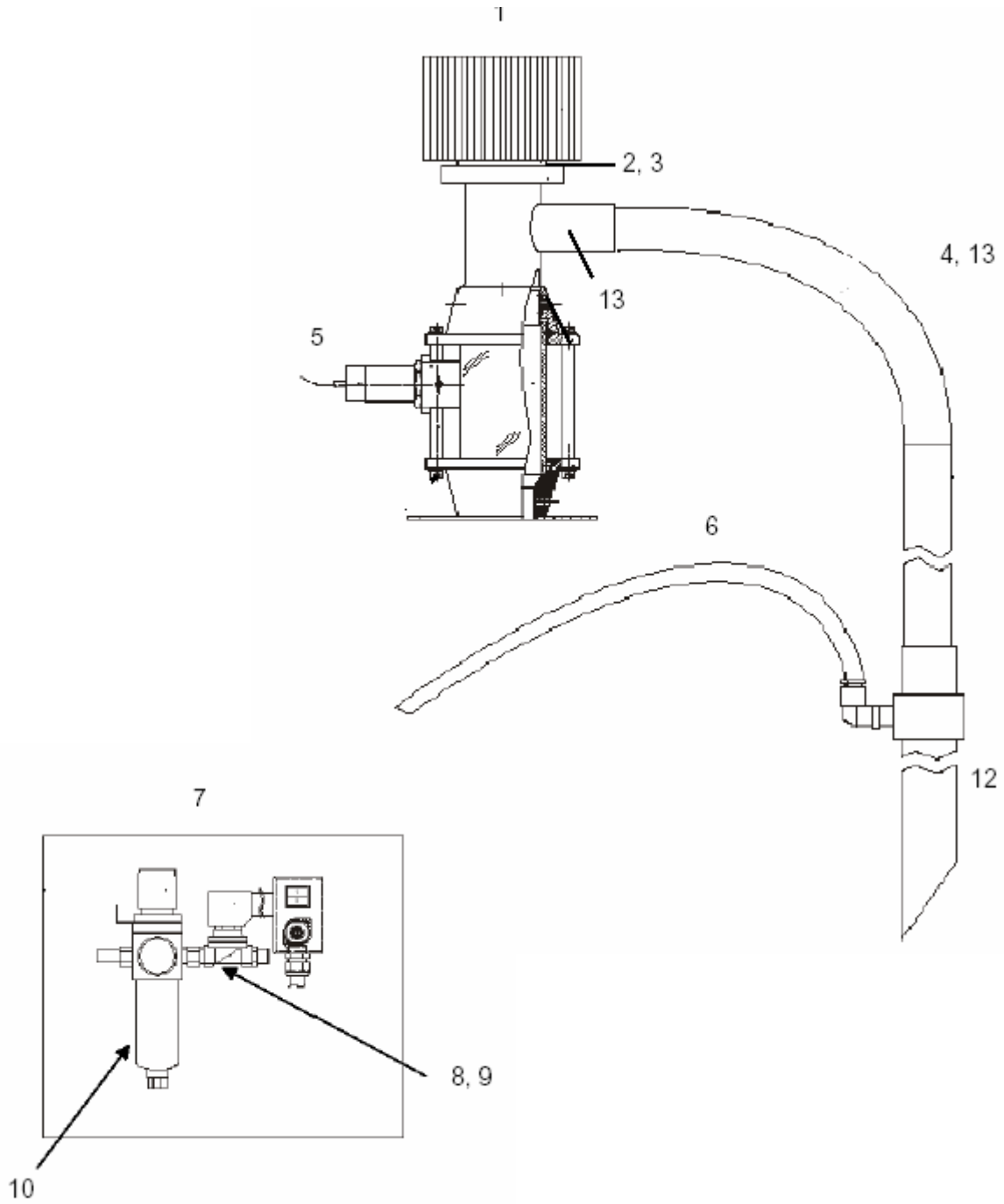

XSV-05R

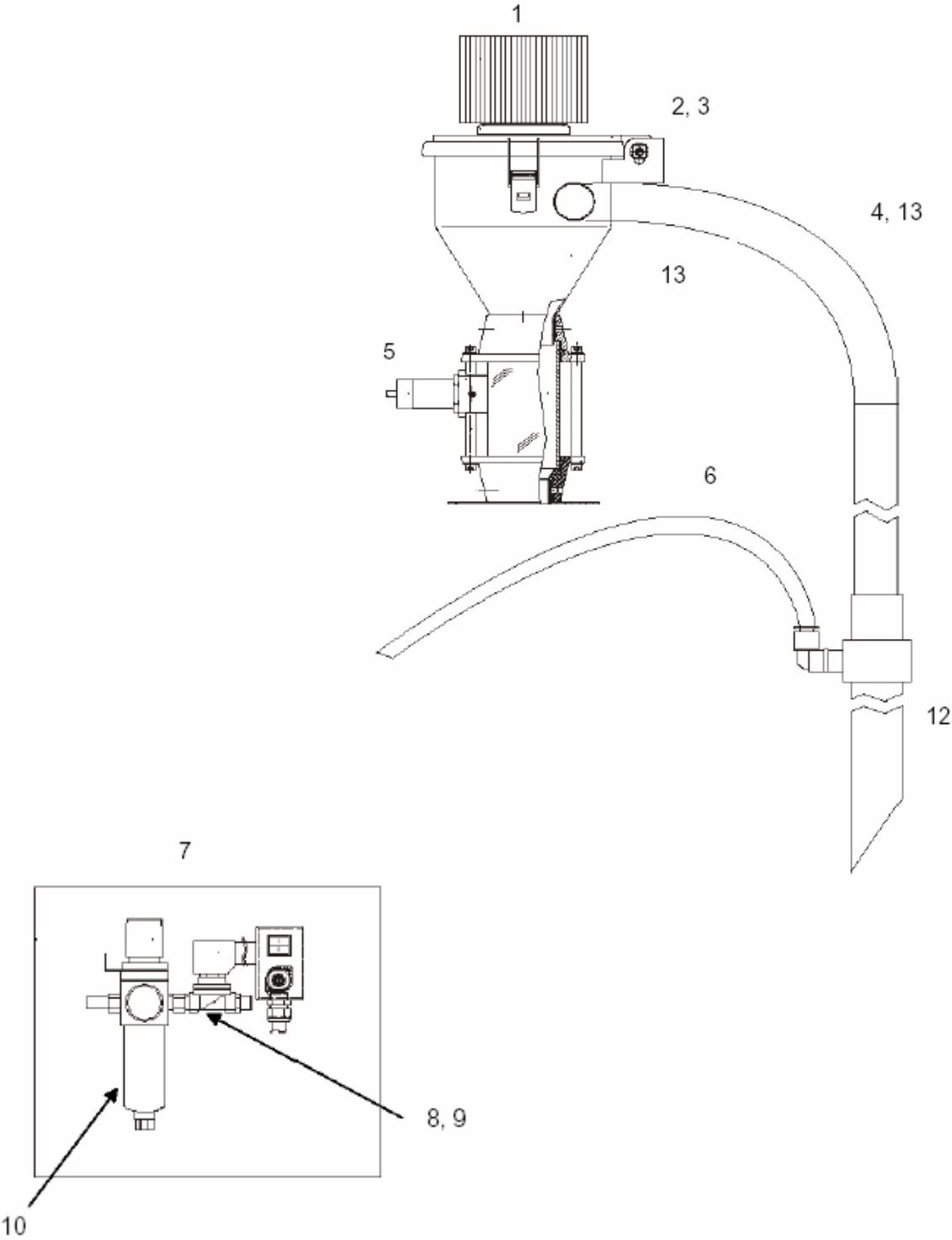

XSV-05/2R

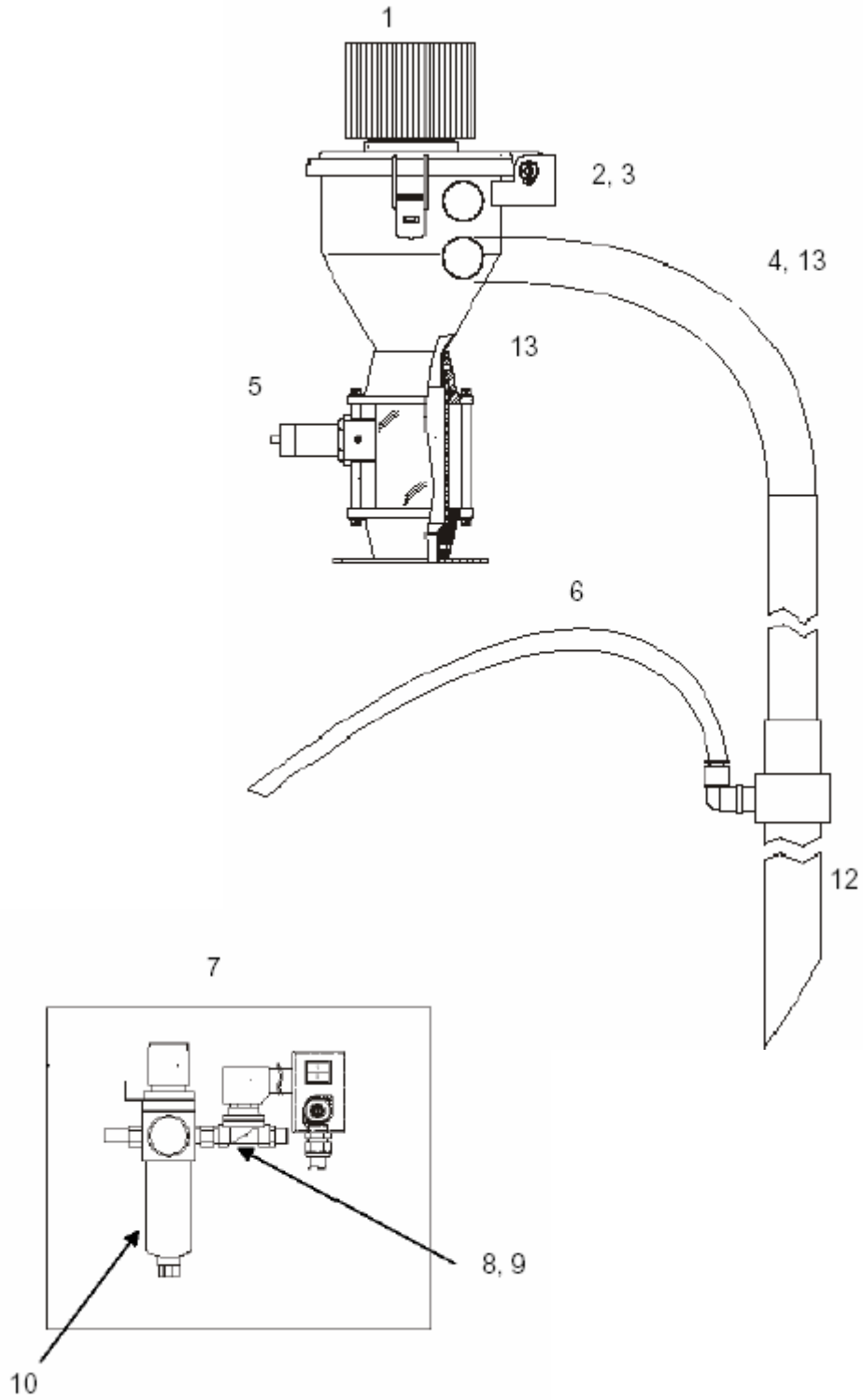

Spare Parts List (See figures on previous pages for parts location)

Position	ID Number	Designation
1	CT98171	Filter cartridge
2	CT18491	Screen (XSV-05 only)
2	CT29252	Screen (XSV-05R or XSV-05/2R)
3	CT31160	Lid gasket (XSV-05 only)
3	CT34161	Lid gasket (XSV-05R or XSV-05/2R)
4	CT100863	Vinyl flexible hose 1.25" x 10 ft.
5	CT85480	Proximity sensor
6	CT88351	Compressed air hose
7	CT29370	Complete control and maintenance unit
8	732.00008.00	Solenoid valve, 110 V
9	732.00066.00	Solenoid valve, 230 V
10	161.00171.00	Filter regulator
11	044.00642.00	Regulator valve (XSV-2R only) – not shown
12	CT31683	Venturi assembly 1.25"
13	CT97784	Hose clamp

6-3 Quick Start Guide –XSV Venturi Loader

Unpack all parts. Check for the following:

- Conveying hopper with level sensor
- Control and maintenance unit
- Venturi assembly
- Vinyl flexible hose
- Compressed air hose
- Operating instructions
- Mount the conveying hopper using the flange provided on its base.
- Mount the control module at a location that is readily accessible. Make sure that the compressed air hose and level sensor cable are long enough to reach the control module.
- Connect the compressed air supply from the control module to the fitting located on the material pick up wand.
- Connect shop compressed air to the regulator on the control module. Compressed air connection must be 70-90 psi (5-6 bar).
- Plug the control module into the main power socket. Make sure that the correct voltage is being used.
- Adjust the level sensor to sense the material that is being conveyed into the conveying hopper.
- Maintain the unit as stated in Chapter 5 of this manual.

6-4 Technical Assistance

Parts Department

Call toll-free 7am–5pm CST [800] 423-3183 or call [630] 595-1060, Fax [630] 475-7005

The ACS Customer Service Group will provide your company with genuine OEM quality parts manufactured to engineering design specifications, which will maximize your equipment's performance and efficiency. To assist in expediting your phone or fax order, please have the model and serial number of your unit when you contact us. A customer replacement parts list is included in this manual for your convenience. ACS welcomes inquiries on all your parts needs and is dedicated to providing excellent customer service.

Service Department

Call toll-free 8am–5pm CST [800] 233-4819 or call [630] 595-1060

Emergencies after 5pm CST, call [847] 439-5655

We have a qualified service department ready to help. Service contracts are available for most products.

Sales Department

Call [630] 595-1060 Monday–Friday, 8am–5pm CST

Our products are sold by a worldwide network of independent sales representatives. Contact our Sales Department for the name of the sales representative nearest you.

Contract Department

Call [630] 595-1060 Monday–Friday, 8am–5pm CST

Let us install your system. The Contract Department offers any or all of these services: project planning; system packages including drawings; equipment, labor, and construction materials; and union or non-union installations.