

MATSUSHITA Compressor

MODEL# QA110K27GAU6

Single Phase
R-134a

115 V
60 Hz

Voltage Range 103 Volts to 127 Volts @ 60 Hz
Application High Back Pressure
Compressor Cooling Fan Cooling

Refrigerant Control . . . Capillary Tube
Evaporator
Temp. Range 23°F to 59°F / -5°C to 15°C

Rated Performance Data

Capacity 3,926 Btu/h ±10% *
E.E.R. 7.51 Btu/Wh ±10% *
Current 6.06 Amps *

Nominal Motor Data Motor Input 523 Watts*
 Rated Current . . . 6.00 Amps
 Type RSIR, PTC relay

Locked Rotor 30.7 Amps
Start Current 36.4 Amps
Coil Resistances Run 1.18 Ohms
 @ 68°F (20°C) Start . . . 7.00 Ohms

*Test Conditions for Performance Specifications

Test Oil Freol α 22
Shell Temp 170.0°F / 76.0°C
Condensing Temp 130.0°F / 54.4°C
Evaporating Temp 45.0°F / 7.2°C
Ambient Temp 95.0°F / 35.0°C
Gas Superheat 95.0°F / 35.0°C
Liquid Sub-Cooling . . . 115.0°F / 46.1°C

Electrical Accessories†

Overload Protector
Nominal Operating Characteristics

Model Name MST18ALZ
Manufacturer Texas Instruments
Temperature To Open: 248°F ± 9°F / 120°C ± 5°C
 Close: 142°F ± 20°F / 61°C ± 11°C
Trip Current @ 158°F (70°C) 8.0 Amps ± 7.5%
 @ 77°F (25°C) 18.3 Amps @ 18 sec. max.

P.T.C. Starting Device
Nominal Operating Characteristics

Model Name	MM8-5CDP4M7	PTH7M4R7MC1	
Manufacturer	Matsushita	Murata Mfg.	
Base resistance			
@ 77°F(25°C) ±20%	4.7	4.7	Ohms
Power Consumption (max)	4.0	3.0	Watts
Operation time	1.5 to 3.5	0.7 to 2.2	seconds
Recovery time (max)	85	70	seconds

Run Capacitor — μF — V (min.)

†Although these accessories are listed by UL/CSA for use with this compressor, Matsushita assumes no responsibility whatsoever for these or any other components sourced by the refrigeration system manufacturer from third parties.

Performance Curves

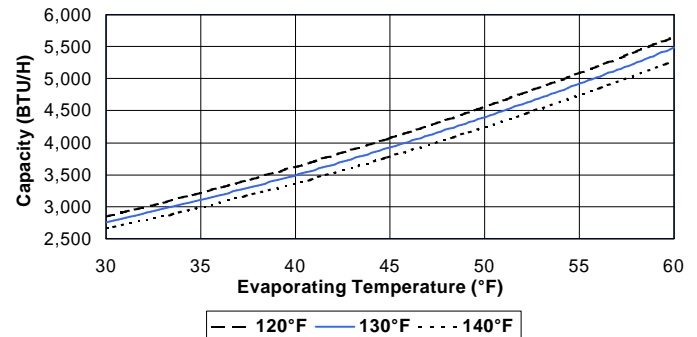
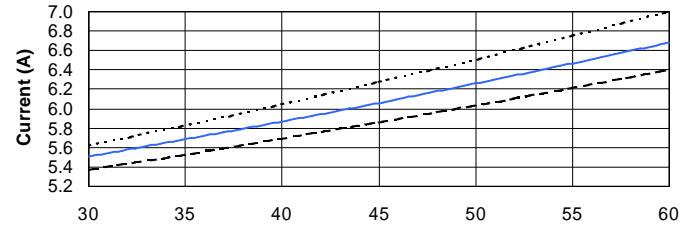
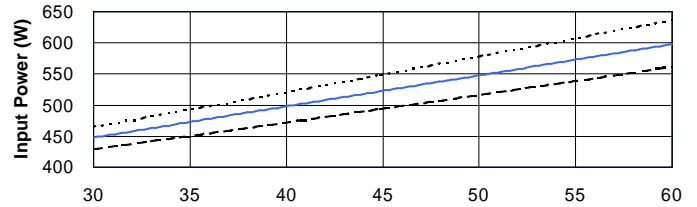

9 - Point Data

Condensing Temp.	Rating	Evaporating Temp.		
		+30°F	+45°F	+59°F
140°F	Btu/h	2,660	3,780	5,469
	Watts	465	549	631
	Amps	5.62	6.27	6.95
	E.E.R.	5.72	6.89	8.19
130°F	Btu/h	2,759	3,926	5,364
	Watts	448	523	593
	Amps	5.51	6.06	6.64
	E.E.R.	6.16	7.51	9.05
120°F	Btu/h	2,847	4,070	5,534
	Watts	429	494	557
	Amps	5.37	5.86	6.36
	E.E.R.	6.64	8.24	9.94



Panasonic Industrial Company
Refrigeration Products Department
Tel: 201 - 392 - 4249
Fax: 201 - 392 - 4315

Rev#1-5/9

MATSUSHITA Compressor

MODEL# QA110K27GAU6

Single Phase
R-134a

115 V
60 Hz

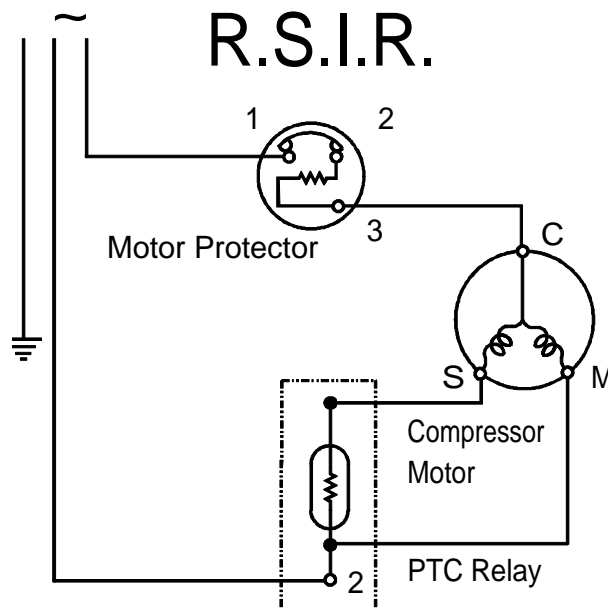
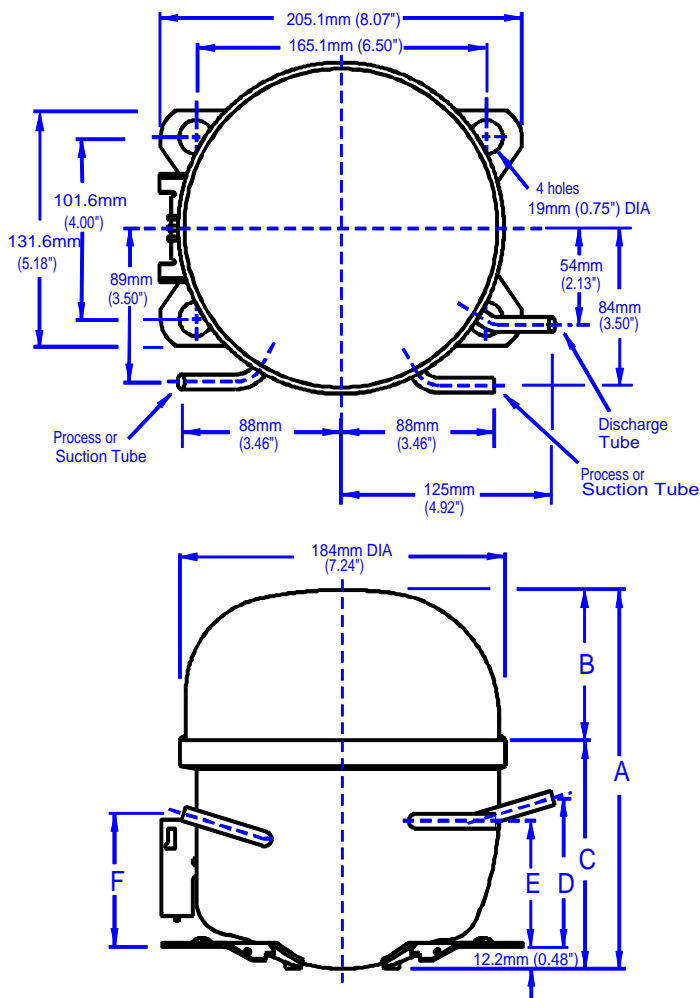

Dimensions*

	mm	inches
A	208.6	8.21
B	92.8	3.65
C	115.8	4.56
D	77.0	3.03
E	62.2	2.45
F	77.0	3.03

* All dimensions are for reference only

This document sets forth certain operational parameters and conditions for operation of this product. If this product is operated outside of the parameters and conditions stated herein, buyer assumes sole and full responsibility and shall indemnify seller with respect to all product failures and all consequences thereof. Operation of the product outside of the parameters and conditions specified herein shall serve to invalidate all seller warranties, if any, with respect to the product. This document is for reference only. For specifications, please contact Panasonic's engineering department.

Tubes	Tube O.D.	Wall	Material
Suction	0.39 in. / 10 mm	0.035 in. / 0.9 mm	Copper
Process	0.39 in. / 10 mm	0.035 in. / 0.9 mm	Copper
Discharge	0.33 in. / 8.3 mm	0.035 in. / 0.9 mm	Copper

U.L. File # SA 4615
 C.S.A. File #'s LR - 34080
 LR - 36593
 LR - 100738

General Data	Oil Charge
Oil Charge	250 cc ± 5 cc / 15.3 cu.in. ± 0.3 cu.in.
Net Weight With Oil	22.2 lbs, 10.1 kg
Approved Oils	FREOL α 22
Residual Moisture	120 mg max.
Impurities	10 mg max.
Displacement	10.86 cc. / 0.663 cu. in.

Panasonic®

Panasonic Industrial Company
 Refrigeration Products Department
 Tel: 201 - 392 - 4249
 Fax: 201 - 392 - 4315

Rev#1-5/9