



2 HP / 4 GALLON AIR COMPRESSOR

OPERATING MANUAL



⚠ WARNING:

**Read carefully and understand RULES FOR SAFE OPERATION
and instructions before operating.**

**Failure to follow the safety rules and other basic safety
precautions may result in serious personal injury.**

Item # 123006

READ ALL INSTRUCTIONS BEFORE OPERATING

SAVE THESE INSTRUCTIONS

Thank you for purchasing your Northern Industrial™ Air Compressor. Before attempting to operate your new tool please read these instructions thoroughly. You will need these instructions for the safety warnings, precautions, assembly, operation and maintenance procedures.

⚠ WARNING: The warnings, cautions and instructions discussed in this instruction manual cannot cover all possible conditions or situations that could occur. It must be understood by the operator that common sense and caution are factors which cannot be built into this product, but must be supplied by the operator.

SPECIFICATIONS

Motor.....	120V ~ 60Hz
HP	2
Weight.....	59.5 lbs
Tank Capacity	4 Gallon
Air Pressure	115 psi
CFM	5.5 CFM@40 psi
.....	3.5 CFM@90 psi
CSA Listed	

TABLE OF CONTENTS

Description	Page #
Specifications	1
Safety rules	2
Know Your Tool.....	3
Getting Started	3
Assembly	3
Operation.....	4
Maintenance	6
Troubleshooting.....	7
Parts List and Diagram.....	8

SAFETY RULES

1. Know your tool. Read this manual carefully. Learn the tool's applications and limitations, as well as specific potential hazards peculiar to it.
2. Ground all tools. If the tool is equipped with three-pin plug, it should be plugged into a three-pin electrical socket. Never remove the ground pin.
3. Avoid body contact with grounded surfaces such as pipes, radiators, ranges, and refrigerators. There is an increased risk of electric shock if your body is grounded.
4. Do not expose tool to moisture. Don't use this tool in damp or wet locations. Keep out of rain.
5. Do not abuse cord. Never use the cord to carry tools or pull the plug from an outlet. Keep cord away from heat, sharp edges or moving parts. Replace damaged cords immediately. Damaged cords increase the risk of electric shock.
6. Remove adjusting keys or wrenches before turning the tool on. A wrench or key that is left attached to a moving part of the tool may result in personal injury.
7. Keep work area clean and well lit. Cluttered or dark work areas invite accidents.
8. Keep children away. All children should be kept away from the work area. Never let a child handle a tool without strict adult supervision.
9. Do not operate this tool if under the influence of alcohol or drugs. Read warning labels on prescriptions to determine if your judgment or reflexes are impaired while taking drugs. If there is any doubt, do not attempt to operate.
10. Use safety equipment. Eye protection should be worn at all times when operating this tool. Use ANSI approved safety glasses. Everyday eyeglasses are NOT safety glasses. Dust mask, non-skid safety shoes, hard hat, or hearing protection should be used in appropriate conditions.
11. Wear proper apparel. Loose clothing, gloves, neckties, rings, bracelets, or other jewelry may present a potential hazard when operating this tool. Please keep all apparel clear of the tool.
12. Don't overreach. Keep proper footing and balance at all times when operating this tool.
13. Always disconnect the tool from power source before making any adjustments, storing, servicing, or changing accessories. Such preventative safety measures reduce the risk of starting the tool accidentally.
14. Do not force tool. Use the correct tool for your application. The correct tool will do the job better and safer at the rate for which it was designed.
15. Do not use the tool if the switch does not turn it on and off. Any tool that cannot be controlled with the switch is dangerous and must be repaired.
16. Check for damage. Check your tool regularly. If part of the tool is damaged it should be carefully inspected to make sure that it can perform its intended function correctly. If in doubt, the part should be repaired. Refer all servicing to a qualified technician. Consult your dealer for advice.
17. Keep away from flammables. Do not attempt to operate this tool near flammable materials or combustibles. Failure to comply may cause serious injury or death.
18. Store idle tools out of the reach of children and untrained persons. Tools may be dangerous in the hands of untrained users.
19. Maintain tools with care. Keep tools sharp and clean. Properly maintained tools, with sharp cutting edges, are less likely to bind and are easier to control.
20. Never exceed the pressure rating of any component in system.
21. Protect material and air lines from damage or puncture. Keep hose and power cable away from sharp objects, moisture, chemicals, oil, etc.
22. Check condition of hoses before each use. Do not use a damaged hose. If hose is damaged, replace immediately.
23. Read, understand and comply with all warning labels on unit.
24. Drain tank of moisture after each use. If Compressor is not to be used for extended periods of time, leave tank drain valve open to allow moisture to completely drain from tank.
25. Do not tamper with Safety Valve. The Safety Valve is factory set for your model air compressor. Any use adjustments to Safety Valve will automatically void warranty.
26. Air compressors get hot while in operation. NEVER touch the motor, discharge tubing or compressor pump while in operation.
27. The Compressor operates automatically while the motor is turned on.
28. Compressed air from the unit may contain carbon monoxide. Air produced is not suitable for breathing purposes.
29. Always use a respirator when spraying paint or chemicals.
30. The air pressure switch is set at the factory for optimum performance of your equipment. Never attempt to bypass or remove this switch as serious damage to equipment or personal injury could result from excessive air pressure.

KNOW YOUR COMPRESSOR

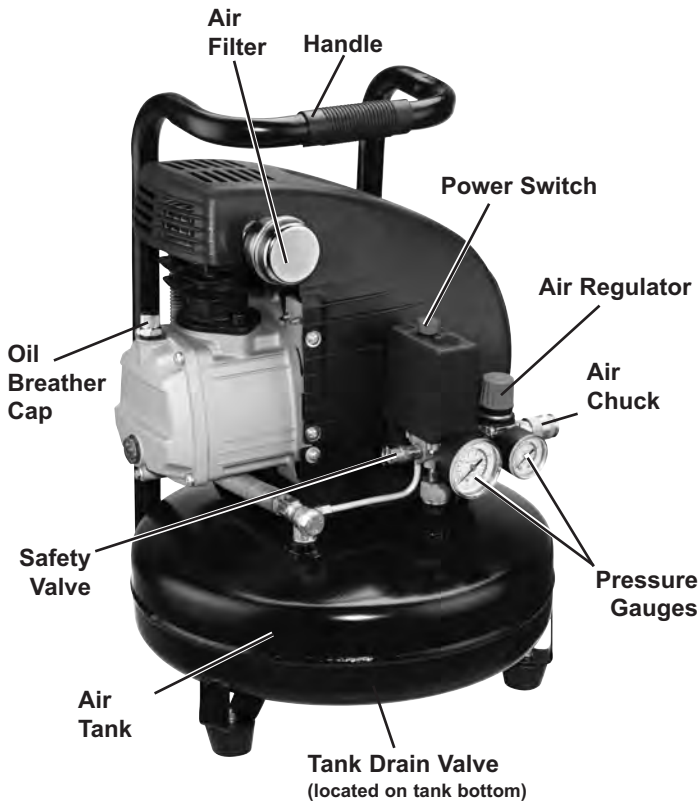

Figure 1. Air Compressor

Handle: Convenient, rubber gripped handle allows for easy transport of your air compressor.

Air Regulator: The air regulator controls the air flow pressure. Turn regulator clockwise to increase air pressure, counter-clockwise to decrease air pressure.

Air Chuck: Convenient quick disconnect air chuck allows for fast, easy connection to an air hose.

Tank Drain Valve: The Tank Drain Valve can be opened to allow moisture and compressed air to be released from the Air Tank.

⚠ WARNING! Tank Drain Valve should always be opened slowly to avoid damage to equipment and possible injury.

Air Filter: This heavy duty metal air filter keeps your compressor running cleanly, by filtering out impurities.

Oil Breather Cap: As the compressor motor operates pressurized air must be released from the crank case. The oil breather cap allows built up air to escape, while shielding your air compressor from airborne impurities.

Power Switch: The red tipped power switch turns the air compressor on and off. When switch is in horizontal position, compressor is turned ON. When switch is in vertical position, compressor is turned OFF.

Note: Always make sure that compressor Power Switch is in the OFF position before performing any maintenance or plugging the compressor into a power supply.

Pressure Gauges: These dual gauges indicate the amount of air pressure built up in the air tank, as well as the air pressure being delivered to the air chuck.

Safety Valve: The Safety Valve device relieves pressure from the Air Tank in the event of excessive pressure build up. The Safety Valve is preset at factory. Do not attempt to make any adjustments to the Safety Valve. Periodically pull ring on the Safety Valve end to check that it is working properly.

Air Tank: Powder coated steel tank, with a 4 gallon capacity, stores the compressed air until it is needed.

GETTING STARTED

Before operating your tool, check the contents of the box to make sure you have everything you will need.

Items included in the box:

- Air Compressor
- Air Filter
- Oil Breather Cap
- Bottle of Oil
- Owner's Manual

ASSEMBLY

NOTE: Before performing any assembly or maintenance make sure compressor is turned off and unplugged from the power supply.

Installing the Oil and Oil Breather Cap

Your air compressor is shipped without oil in the crankcase. BEFORE STARTING THE AIR COMPRESSOR YOU MUST ADD OIL TO THE CRANKCASE AS DESCRIBED BELOW:

1. Place compressor on level ground.
2. Remove the Oil Shipping Plug from the Oil Fill hole, located on the top of the crankcase cover at the rear of the air compressor.
3. Slowly pour the oil into the Oil Fill hole, until the oil level rises to the center of the red dot on the Oil Sight Glass.

Note: This compressor uses only SAE 5W-30 motor oil.

4. Install the Oil Breather Cap into the Oil Fill hole. Firmly hand tighten the Oil Breather Cap by turning clockwise.

(See Figure 2)

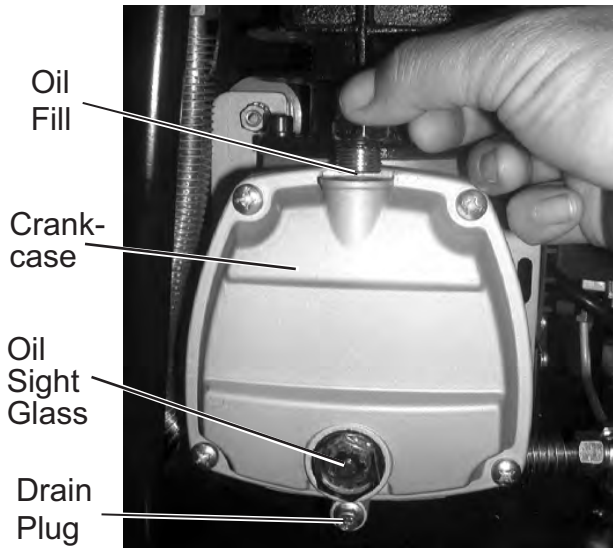

Figure 2. Installing the Oil & Oil Breather Cap

Installing the Air Chuck

Note: The use of a sealant tape is recommended on the threads of the Air Chuck to prevent air leakage.

1. Thread the Air Chuck into the Air Regulator by turning the Air Chuck clockwise.
2. Securely tighten the Air Chuck in place with a wrench.

Note: DO NOT over tighten Air Chuck.
(See Figure 3)



Figure 3. Installing the Air Chuck

Installing the Air Filter

The metal Air Filter is installed into the threaded port of the cylinder head.

1. Thread the Air Filter into the Cylinder Head by turning the Air Filter clockwise.
2. Securely tighten the Air Filter in place with a wrench.

(See Figure 4)



Figure 4. Installing the Air Filter

Note: DO NOT over tighten Air Filter.

OPERATION

BEFORE OPERATING YOUR NEW AIR COMPRESSOR

please check the following points carefully:

1. Check that all nuts and bolts are secure.
2. Make sure oil has been properly added to compressor. (See Installing Oil and Oil Breather Cap section.)

Initial Start-Up Procedure

1. Open the Air Tank Drain Valve to permit air to escape, preventing air pressure buildup in the air tank.
2. Run the compressor for a minimum of 20 minutes in this “no-load” position to lubricate the piston and bearings.
3. Close Air Tank Drain Valve. Your compressor is ready for use.

Depending on the CFM draw of the tools being operated, your new Air Compressor can be used for operating paint sprayers, air tools, grease guns, airbrushes, caulking guns, abrasive blasters, tire & plastic toy inflation, spraying weed killer and insecticides, etc. Proper adjustment of the Air Pressure Regulator is necessary for all of these operations. Refer to the air pressure specifications provided with the tool you are using.

General Overview

To compress air, the piston moves up and down in the cylinder. On the down stroke air is drawn in through the valve inlet. The discharge valve remains closed. On the upstroke of the piston air is compressed. The inlet valve closes and air is forced out through the discharge valve, through the check valve, and into the air tank. Working air is not available until the compressor has raised the tank

pressure above that required at the air service connection. The air inlet filter openings must be kept clear of obstructions, which could reduce air delivery of the compressor.

Installation and Location

Locate the compressor in a clean, dry and well ventilated area. The compressor should be located 12 to 18 inches from walls or any other obstruction which would interfere with airflow. Compressor should be located in a temperature controlled area between 32° and 95° fahrenheit. Place the compressor on a firm, level surface. The compressor is designed with heat dissipation fins which allow for proper cooling. Keep the fins (and all other parts which collect dust or dirt) clean. A clean compressor runs cooler and provides longer service. Do not place rags, containers or other material on top of the compressor.

Connecting to Power Source

This air compressor is designed to operate on a properly grounded 120 volt, 60Hz, single phase, alternating current (ac) power source with a fused 20 amp time delayed fuse or circuit breaker. It is recommended that a qualified electrician verify the ACTUAL VOLTAGE at the receptacle into which the unit will be plugged and confirm that the receptacle is properly fused and grounded. The use of the proper circuit size can eliminate nuisance circuit breaker tripping while operating your air compressor.

Extension Cords

For optimum Air Compressor performance an extension cord should not be used unless absolutely necessary. If necessary, care must be taken in selecting an extension cord appropriate for use with your specific Air Compressor. Select a properly grounded extension cord which will mate directly with the power source receptacle and the Air Compressor power cord without the use of adapters. Make certain that the extension cord is properly wired and in good electrical condition. Maximum length of extension cord should be 50 feet. Minimum wire size of extension cord should be 12 gauge.

Attaching an Air Hose

Your Air Compressor is supplied with a 1/4" Quick Disconnect Air Chuck. Once you have correctly installed the Air Chuck (See Installing the Air Chuck on p.4) your compressor will be ready to accept air hoses equipped with 1/4" male air couplers.

Note: Use only air hoses rated for use with 115psi air pressure or higher.

To install an air hose, equipped with a 1/4" male coupler:

1. Pull back on Air Chuck outer sleeve to allow coupler to be fully inserted into Air Chuck.
 2. Insert coupler into Air Chuck.
 3. Release outer sleeve of Air Chuck.
 4. Verify that air hose is securely connected to Air Chuck by pulling lightly on air hose.
- (See Figure 5)

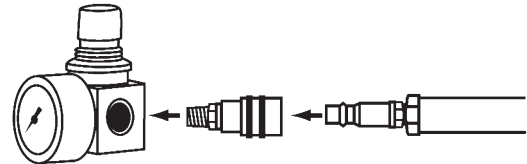

Figure 5. Attaching an Air Hose

Adjusting the Air Pressure

Your Air Compressor is supplied with an Air Pressure Regulator. This Regulator adjusts the air pressure.

To increase air pressure, turn Air Regulator clockwise.

To decrease air pressure, turn Air Regulator counterclockwise.

(See Figure 6)



Figure 6. Adjusting the Air Pressure

Cold Weather Starting

Temperatures below freezing (32°F) cause the metal parts of your Air Compressor to contract and that makes starting more difficult. To assist the Air Compressor in starting in cold weather, follow these tips:

1. Try to keep Air Compressor stored in temperatures above 32° fahrenheit.
2. Open the Air Tank Drain Valve and release all air pressure from the Air Tank before attempting to start in cold weather. (After air is released from Air Tank, close Drain Valve.)
3. Plug Air Compressor directly into a 120 volt electrical outlet. Do not use an extension cord when starting your Air Compressor in cold weather.

MAINTENANCE

Daily (or before each use)

1. Check oil level
2. Drain condensation from the air tank.
3. Check for any unusual noise or vibration.
4. Be sure all nuts and bolts are tight.

Weekly

1. Clean breather hole on Oil Breather Cap.

Monthly

1. Inspect air system for leaks by applying soapy water to all joints. Tighten these joints if leaks are discovered.

6 Months (or after 250 hours of operation - whichever comes first)

1. Change Air Compressor Oil.

Note: Change oil more often if Air Compressor is used near paint spraying operations or in dusty environments.

Checking the Air Compressor Oil

1. Place Air Compressor on level surface. The oil level should be at the red dot on the Oil Sight Glass.
2. If oil level is low, remove Oil Breather Cap and add enough oil to bring the oil level to the red dot on the Oil Sight Glass.
3. Replace Oil Breather Cap before starting compressor.

Changing the Air Compressor Oil

Note: This compressor uses only SAE 5W-30 motor oil.

1. Remove the Drain Plug under the Oil Sight Glass by turning the nut counter-clockwise with wrench. (See Figure 2.)

Note: Oil will begin to drain as Drain Plug is loosened. Place a funnel and oil pan in place BEFORE loosening Drain Plug.

2. Once Drain Plug is removed, tilt Air Compressor backwards to allow all of the oil to drain out of the crankcase.
3. Once oil is drained, replace Drain Plug and securely tighten in place with a wrench. Be careful not to overtighten the Drain Plug, as this could damage the rubber seal.
4. Place Air Compressor on level surface.
5. Remove the Oil Breather Cap.
6. Slowly pour the oil into the oil fill hole, until the oil level rises to the center of the red dot on the Oil Sight Glass.
7. Install the Oil Breather Cap into the oil fill hole.
8. Firmly hand tighten the Oil Breather Cap by turning clockwise.

Always inspect the tool before use, and make sure it is in good working condition. Make sure all air vents are clear, (use compressed air to clean the machine where possible). Check the power cable to make sure it is intact and free from cracks, bare wires etc. Avoid using solvents when cleaning plastic parts. Most plastics are susceptible to damage from the various types of commercial solvents.

TROUBLESHOOTING

TROUBLE	POSSIBLE CAUSE	CORRECTIVE ACTION
Compressor Won't Start	<ol style="list-style-type: none"> 1. Blown Fuse or Circuit Breaker Tripped 2. Loose Electrical Connections 	<ol style="list-style-type: none"> 1. Replace or Reset Fuse/Circuit Breaker 2. Check Wiring Connections
Low Pressure	<ol style="list-style-type: none"> 1. Restricted Air Filter 2. Defective Check Valve 3. Air Leak in Safety Valve 	<ol style="list-style-type: none"> 1. Replace Air Filter 2. Replace Check Valve 3. Check valve by pulling on ring. If condition persists, replace valve.
Safety Valve Releasing	<ol style="list-style-type: none"> 1. Defective Pressure Switch 	<ol style="list-style-type: none"> 1. Replace Pressure Switch
Oil Discharge in Air	<ol style="list-style-type: none"> 1. Too much Oil in Crankcase 2. Compressor Overheated 3. Restricted Oil Breather Cap 	<ol style="list-style-type: none"> 1. Drain Crankcase and refill to proper level on Oil Sight Glass. 2. Reduce air pressure regulation 3. Clean or Replace Oil Breather Cap

Parts List and Diagram

Part No.	Description	Part No.	Description	Part No.	Description
01	Plastic Housing	23	Drain Plug	46	Cylinder Head
02	Spring Washer	24	Pan Head Screw	47	Elbow Exhaust
03	Washer	25	Oil Breather Cap	48	Exhaust Pipe
04	Screw M5x14	26	Spring Washer 8	49	Check Valve
05	Fan	27	Washer 8	50	Unload Pipe
06	Screw M5x115	28	Screw M8x20	51	Air Tank
07	Rear Cap	29	Connecting Rod	52	Tank Drain Valve
08	Washer	30	Piston	53	Rubber Feet
09	Bearing 6202	31	Spring Washer 12	54	Screw M6x20/nut M6
10	Stator	32	Piston Pin	55	Power Cord
11	Rotor	33	Cylinder Gasket	56	Rubber Gasket
12	Starting Capacitor	34	Cylinder	57	Centrifugal Switch
13	Running Capacitor	35	Spring Washer 6	58	Seal Washer
14	Bearing 6204	36	Washer 6	59	Nut
15	Oil Seal	37	Screw M6x40	60	Connector Seat
16	Nut M8	38	Gasket	61	Rubber Grip
17	Crankcase	39	Sealer Ring	62	Safety Valve
18	Crankshaft	40	Valve Gasket	63	Pressure Gauge
19	Screw M8x16 (left hand)	41	Valve Plate Assy	64	Pressure Switch
20	Gasket	42	Air Intake Valve	65	Connector
21	Crankcase Cover	43	Limit Pin	66	Pressure Gauge
22	Oil Sight Glass	44	Cylinder gasket	67	Regulator
		45	Metal Air Filter	68	Air Chuck

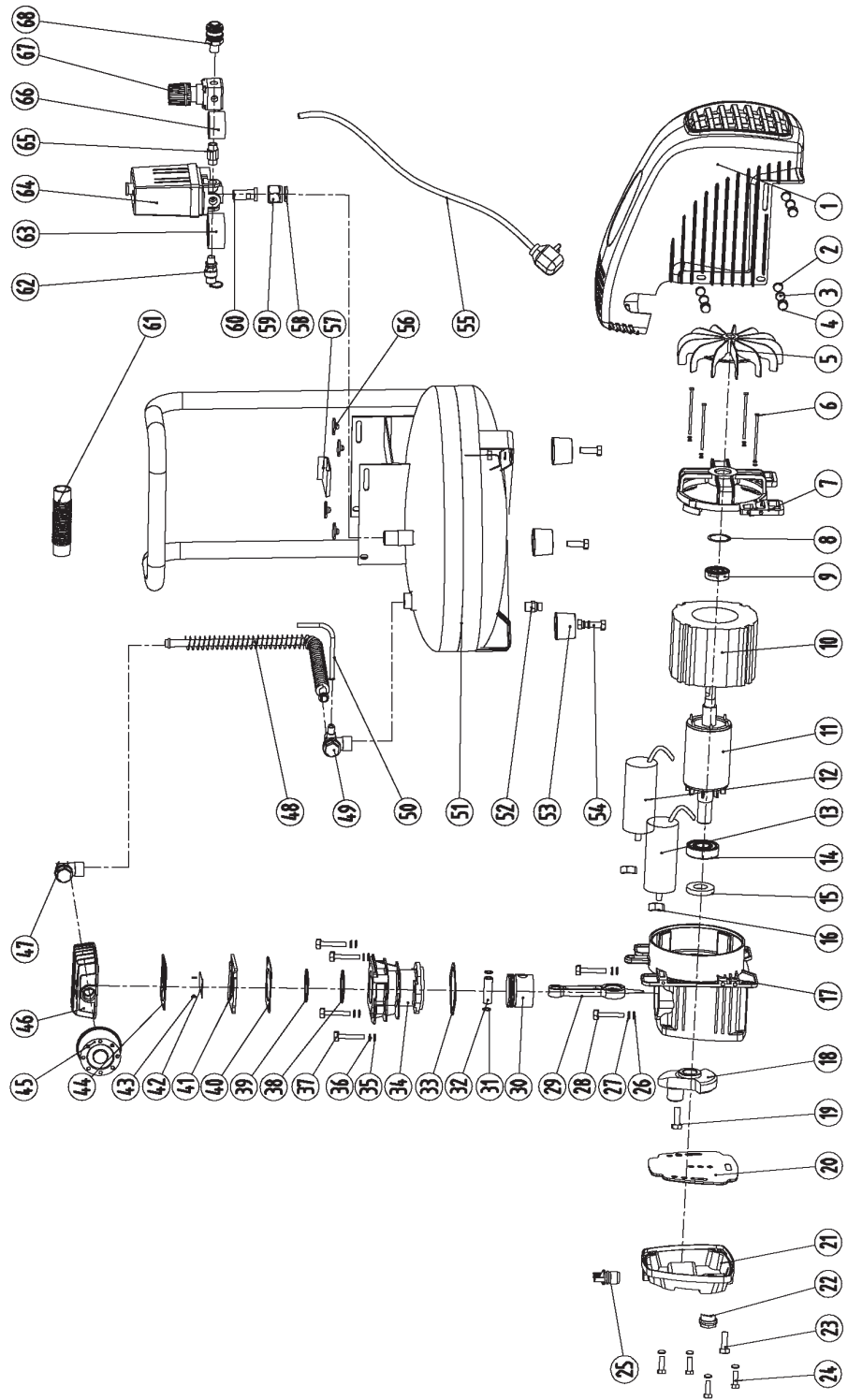

 **WARNING!**

Some dust created by power sanding, sawing, grinding, and other construction activities contains chemicals known to cause cancer, birth defects, or other reproductive harm. Some examples of these chemicals are:

- Lead, from lead-based paints
- Crystalline silica, from bricks, cement, and other masonry products
- Arsenic and chromium, from chemically treated lumber

Your risk from these exposures varies, depending on how often you do this type of work. To reduce your exposure to these chemicals: work in a well-ventilated area, and use approved personal protective equipment, such as dust masks that are specially designed to filter out microscopic particles.



Northern Tool + Equipment Co.,
2800 Southcross Drive West
P.O. Box 1499 Burnsville, MN55337-0499
Made in China