

Grizzly Industrial, Inc.®

MODEL H8209 14-PIECE AIR TOOL KIT INSTRUCTION MANUAL



COPYRIGHT © SEPTEMBER, 2007 BY GRIZZLY INDUSTRIAL, INC.
WARNING: NO PORTION OF THIS MANUAL MAY BE REPRODUCED IN ANY SHAPE
OR FORM WITHOUT THE WRITTEN APPROVAL OF GRIZZLY INDUSTRIAL, INC.
#JM9879 PRINTED IN CHINA

SAFETY

WARNING

For Your Own Safety Read Instruction Manual Before Operating This Equipment

The purpose of safety symbols is to attract your attention to possible hazardous conditions. This manual uses a series of symbols and signal words which are intended to convey the level of importance of the safety messages. The progression of symbols is described below. Remember that safety messages by themselves do not eliminate danger and are not a substitute for proper accident prevention measures.



Indicates an imminently hazardous situation which, if not avoided, **WILL** result in death or serious injury.



Indicates a potentially hazardous situation which, if not avoided, **COULD** result in death or serious injury.



Indicates a potentially hazardous situation which, if not avoided, **MAY** result in minor or moderate injury. It may also be used to alert against unsafe practices.

NOTICE

This symbol is used to alert the user to useful information about proper operation of the equipment.

WARNING

Safety Instructions For Pneumatic Tools

- 1. READ THIS MANUAL.** This tool may cause personal injury if used incorrectly. This manual contains proper safety and operating instructions that must be followed to reduce this risk.
- 2. WEAR EYE PROTECTION.** This tool may throw small fragments during operation, which may cause serious eye injury. Always wear ANSI approved safety glasses or face shield to reduce your risk from this hazard.
- 3. WEAR A RESPIRATOR.** This tool may produce fine dust during operation, which can cause respiratory injury if inhaled. Always wear a respirator NIOSH approved for the type of material being processed.
- 4. WEAR HEARING PROTECTION.** Operating this tool for prolonged time periods may damage your hearing. Your risk depends on length and frequency of use. To reduce your risk of this hazard, wear hearing protection.
- 5. MAINTAIN SAFETY GUARDS.** Your tool may be equipped with safety guards or other structural components designed to reduce the risk of injury during operation. Never modify or operate this tool with any guards or components removed or damaged.
- 6. KEEP CHILDREN AWAY.** Prevent children from injury by keeping them away from this tool. Disconnect and lock the tool away when not in use.

7. **AVOID ENTANGLEMENTS.** Do not wear loose clothing, gloves, neckties, rings, bracelets, or other jewelry, which may get caught in moving parts, when operating this tool. Wear a protective hair covering to contain long hair.
8. **USE CORRECT AIR PRESSURE.** Exceeding the maximum PSI rating of this tool may cause unpredictable operation or bursting.
9. **DISCONNECT AIR PRESSURE** before servicing, changing accessories, or moving to another location. Never leave this tool unattended when connected to air.
10. **SECURE TOOLING.** Always verify tooling is secure before operation.
11. **SHARP SURFACES.** DO NOT place hands near the tooling surfaces when in operation.
12. **REMOVE ADJUSTING KEYS AND WRENCHES AFTER USE.** These tools become dangerous projectiles if left on the tool when it is started.
13. **AVOID FLAMMABLES.** Do not use this tool around any flammables that may be ignited by sparks.
14. **SECURE WORK.** Use clamps or a vise to hold work when practical. It is safer than using your hand and frees both hands to operate tool.
15. **MAINTAIN TOOLS WITH CARE.** Keep tools lubricated and clean for best and safest performance. Follow instructions for lubricating and changing accessories.
16. **DO NOT FORCE TOOL.** It will do the job better and safer at the rate for which it was designed.
17. **CHECK FOR DAMAGED PARTS BEFORE USING.** Check for binding and alignment of parts, broken parts, part mounting, loose bolts, and any other conditions that may affect operation. Repair or replace damaged parts before operating.
18. **USE GOOD LIGHTING.** Keep work area well lighted. Dark work areas increase risk of accidental injury.
19. **AVOID UNINTENTIONAL OPERATION.** Always disconnect air when not in use, and do not carry tool with hand on trigger.
20. **USE THE RECOMMENDED ACCESSORIES.** Consult owner's manual for recommended accessories. Using improper accessories may increase the risk of injury.
21. **NEVER ALLOW UNTRAINED USERS TO USE THIS TOOL WHILE UNSUPERVISED.**
22. **IF YOU ARE UNSURE OF THE INTENDED OPERATION, STOP USING TOOL.** Seek formal training or research books or magazines that specialize in pneumatic tools.
23. **BE AWARE OF HOSE LOCATION.** Hoses can easily become a tripping hazard when laid across the floor in a disorganized fashion.
24. **DO NOT USE UNDER THE INFLUENCE OF DRUGS OR ALCOHOL, OR WHEN TIRED.**

CAUTION

No list of safety guidelines is complete, because every work environment is different. Always consider safety first and use common sense. Failure to use this tool with caution and respect could result in serious personal injury.

Inventory

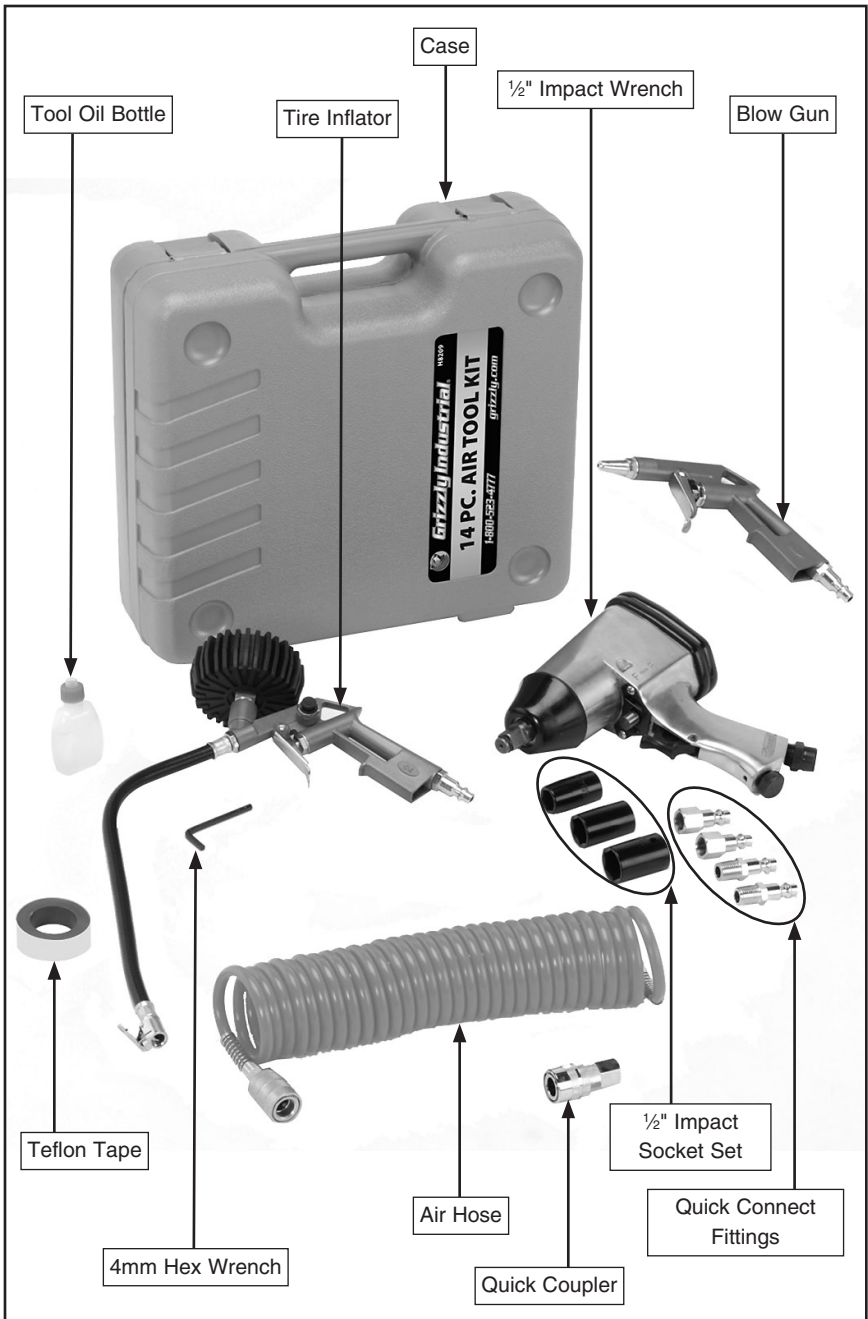
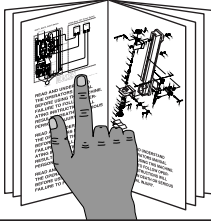

Figure 1. Model H8209 Inventory.

OPERATIONS

!WARNING



Read the manual before operation. Become familiar with this tool, its safety instructions, and its operation before beginning any work. Serious personal injury may result if safety or operational information is not understood or followed.

!WARNING



LUNG/EAR INJURY HAZARD!
Wear protective equipment when using this tool.

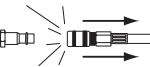

ACCIDENTAL START HAZARD!
Disconnect before service or tool changes.

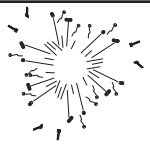

AIR PRESSURE HAZARD!
Never exceed 120 PSI.

Impact Wrench Specifications

Drive Size.....1/2"
No Load Speed.....7000 RPM
Max. Torque.....230 ft/lb (310N.m)
Air Inlet.....1/4"
Air Hose ID.....3/8"
Operating Air Pressure.....90 PSI
Average Air Consumption.....4 CFM
Weight.....5.4 lbs

Air Supply

The impact wrench requires 90 PSI to operate correctly. To improve air tool lifespan, use a filter/lubricator/regulator setup shown in **Figure 2**.

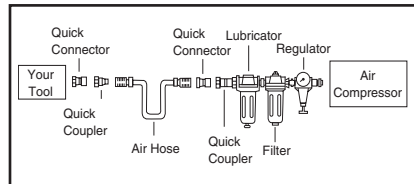

Figure 2. Installed filter lubricator regulator.

Otherwise, lubricate the impact wrench daily with a couple drops of pneumatic tool oil directly into the tool's air inlet fitting, as shown in **Figure 3**, before and after each use.

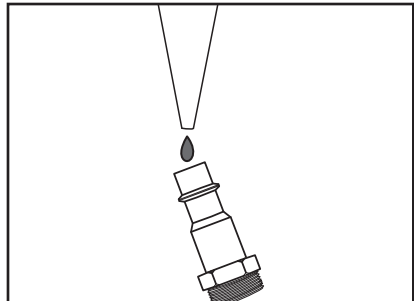

Figure 3. Manual oiling.

! WARNING



**EYE INJURY
HAZARD!**
Wear protective
equipment when
using these tools.

Impact Wrench

Your new single hammer $\frac{1}{2}$ " drive impact wrench (**Figure 2**) will generate up to 230 ft/lbs. of torque.

Only use thick-walled impact sockets with this air tool. The common thin-walled chrome sockets may explode if used as impact sockets causing serious injury.

At the end of the handle you can adjust the torque setting by pushing the knob in and turning the knob to 1, 2, 3, or 4; 1 is the lowest torque setting.

To change the impact rotation, push the slide button toward the front of the gun for clockwise rotation and to the rear for counterclockwise rotation.

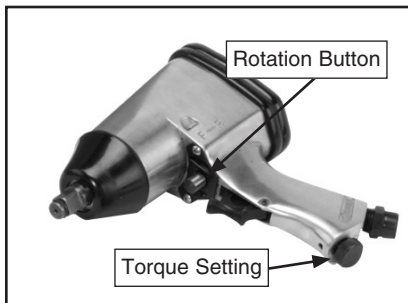

Figure 4. Impact wrench locations.

Tire Inflator

1. Connect the air hose to the tire inflator.
2. Connect inflator to the tire air valve.

3. Pull the trigger until the appropriate air pressure is reached.
4. If the pressure in the tire is too high, push the pressure release valve to bleed the excess pressure.

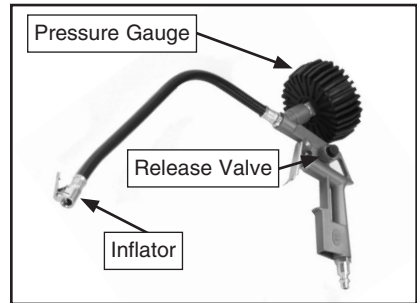

Figure 5. Tire inflator locations.

Blow Gun

1. Attach the blow gun to the air supply with the air hose.
2. Aim the blow gun at the workpiece and pull the trigger. *DO NOT point the blow gun in the direction of yourself or others.*

Daily Maintenance

Your impact wrench **MUST** have 2-6 drops of oil directly dropped into the air fitting before each use. In addition, we recommend using an in-line filter, lubricator, and regulator, as shown in **Figure 2**. If an in-line lubricator is not used, add 2-3 drops of oil into the tool air inlet every 2 hours of continued use.

These procedures should be done after each use:

- Before putting the impact wrench away, put 2-6 drops of oil into the air supply fitting and momentarily operate the impact wrench to distribute the oil inside the tool.
- Wipe the tool exterior and sockets with a slightly oiled cloth. Your goal is to leave a light film of oil on the tools to prevent rust.

AIR IMPACT WRENCH

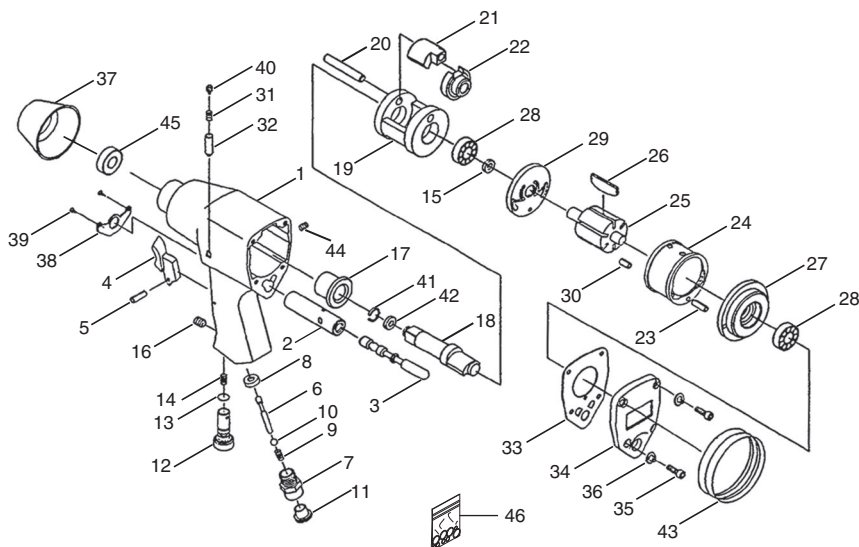

REF PART #	DESCRIPTION
1	PH8209001 HOUSING
2	PH8209002 VALVE BUSHING
3	PH8209003 REVERSE VALVE
4	PH8209004 TRIGGER
5	PRP02M ROLL PIN 3 X 16
6	PH8209006 VALVE STEM
7	PH8209007 AIR INLET
8	PH8209008 BALL SEAT
9	PH8209009 COMPRESSION SPRING
10	PH8209010 STEEL BALL
11	PH8209011 COVER
12	PH8209012 AIR REGULATOR
13	PORP009 O-RING 8.8 X 1.9 P9
14	PH8209014 COMPRESSION SPRING
15	PH8209015 OIL SEAL
16	PH8209016 PILOT SET SCREW M5-.8 X 6
17	PH8209017 BUSHING
18	PH8209018 ANVIL
19	PH8209019 HAMMER CAGE
20	PH8209020 HAMMER PIN
21	PH8209021 HAMMER DOG
22	PH8209022 DRIVE CAM
23	PRP15M ROLL PIN 3 X 8

REF PART #	DESCRIPTION
24	PH8209024 CYLINDER
25	PH8209025 ROTOR
26	PH8209026 ROTOR BLADE
27	PH8209027 REAR END PLATE
28	P6001 BALL BEARING 6001ZZ
29	PH8209029 FRONT END PLATE
30	PRP61M ROLL PIN 3 X 12
31	PH8209031 COMPRESSION SPRING
32	PH8209032 PIN 4 X 7
33	PH8209033 GASKET
34	PH8209034 REAR COVER
35	PSB15M CAP SCREW M5-.8 X 20
36	PLW01M LOCK WASHER 5MM
37	PH8209037 FRONT RUBBER
38	PH8209038 EXHAUST DEFLECTOR
39	PS12M PHLP HD SCR M3-.5 X 6
40	PSS26M SET SCREW M5-.8 X 6
41	PH8209041 C-CLIP 12MM
42	PORP006 O-RING 5.8 X 1.9 P6
43	PH8209043 RUBBER
44	PSS20M SET SCREW M8-1.25 X 8
45	PH8209045 OIL SEAL
46	PH8209046 O-RING KIT

ACCESSORIES

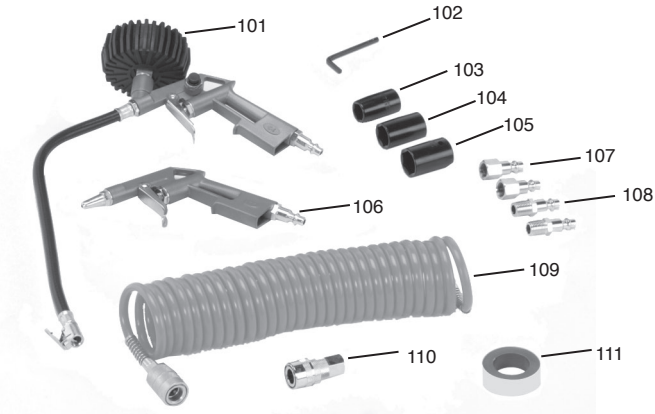

REF	PART #	DESCRIPTION
101	PH8209101	TIRE INFLATOR
102	PH8209102	HEX WRENCH 4MM
103	PH8209103	SOCKET 14MM
104	PH8209104	SOCKET 17MM
105	PH8209105	SOCKET 19MM
106	PH8209106	BLOW GUN

REF	PART #	DESCRIPTION
107	PH8209107	FEMALE CONNECT FITTING
108	PH8209108	MALE CONNECT FITTING
109	PH8209109	AIR HOSE
110	PH8209110	QUICK COUPLER
111	PH8209111	TEFLON TAPE