

Owner's Manual



Permanently Lubricated Tank Mounted **AIR COMPRESSOR**

Model No.
919.152160

- **Safety Guidelines**
- **Assembly**
- **Operation**
- **Maintenance**
- **Service and Adjustments**
- **Troubleshooting**
- **Repair Parts**

CAUTION: Read the Safety Guidelines
and All Instructions Carefully Before
Operating.

Sears, Roebuck and Co., Hoffman Estates, IL 60179 U.S.A.
Visit our Craftsman website: www.sears.com/craftsman

TABLE OF CONTENTS

WARRANTY	2
SPECIFICATION CHART	3
SAFETY GUIDELINES - DEFINITIONS	3
IMPORTANT SAFETY INSTRUCTIONS	3-9
GLOSSARY	9
ACCESSORIES	9
DUTY CYCLE	9
ASSEMBLY	10
INSTALLATION	10-11
OPERATION	12-14
MAINTENANCE	14-15
SERVICE AND ADJUSTMENTS	15-16
STORAGE	16
TROUBLESHOOTING	17-19
REPAIR PARTS	20-23
ESPAÑOL	24-41
REPAIR PROTECTION AGREEMENT	43
HOW TO ORDER REPAIR PARTS	back cover

WARRANTY

ONE YEAR FULL WARRANTY

If this product fails due to a defect in material or workmanship within one year from the date of purchase, Sears will at its option repair or replace it free of charge. Contact Sears at 1-800-4-MY-HOME® to arrange for repair, or return it to the place of purchase for replacement.

If this product is used for commercial or rental purposes, this warranty applies for only ninety days from the date of purchase.

This warranty gives you specific legal rights and you may have other rights which vary from state to state.

Sears, Roebuck and Co., Dept. 817WA, Hoffman Estates, IL 60179

SPECIFICATION CHART

Model No.	919.152160
Running HP	0.8*
Bore	1-7/8"
Stroke	1-1/4"
Voltage-Single Phase	120V
Minimum Branch Circuit Requirement	10 amps
Fuse Type	Time Delay
Air Tank Capacity	6 gallon
Approx. Cut-In	120 PSI
Approx. Cut-out	150 PSI
SCFM @ 40 PSIG	3.7*
SCFM @ 90 PSIG	2.6*

*Tested per ISO 1217

Refer to Glossary for abbreviations.

SAFETY GUIDELINES - DEFINITIONS

This manual contains information that is important for you to know and understand. This information relates to protecting **YOUR SAFETY** and **PREVENTING EQUIPMENT PROBLEMS**. To help you recognize this information, we use the symbols below. Please read the manual and pay attention to these symbols.

<p>▲ DANGER: Indicates an imminently hazardous situation which, if not avoided, will result in death or serious injury.</p>	<p>▲ CAUTION: Indicates a potentially hazardous situation which, if not avoided, <u>may</u> result in minor or moderate injury.</p>
<p>▲ WARNING: Indicates a potentially hazardous situation which, if not avoided, <u>could</u> result in death or serious injury.</p>	<p>CAUTION: Used without the safety alert symbol indicates a potentially hazardous situation which, if not avoided, may result in <u>property damage</u>.</p>

IMPORTANT SAFETY INSTRUCTIONS

▲ WARNING: This product contains chemicals known to the State of California to cause cancer, and birth defects or other reproductive harm. Wash hands after handling.

▲ WARNING: Some dust contains chemicals known to the State of California to cause cancer, birth defects or other reproductive harm such as asbestos and lead in lead based paint.

▲ WARNING: Do not operate this unit until you read and understand this instruction manual for safety, operation and maintenance instructions.



SAVE THESE INSTRUCTIONS

HAZARD



▲ DANGER: RISK OF EXPLOSION OR FIRE

WHAT CAN HAPPEN	HOW TO PREVENT IT
<ul style="list-style-type: none">It is normal for electrical contacts within the motor and pressure switch to spark.	<ul style="list-style-type: none">Always operate the compressor in a well ventilated area free of combustible materials, gasoline, or solvent vapors.
<ul style="list-style-type: none">If electrical sparks from compressor come into contact with flammable vapors, they may ignite, causing fire or explosion.	<ul style="list-style-type: none">If spraying flammable materials, locate compressor at least 20 feet (6.1 m) away from spray area. An additional length of air hose may be required.Store flammable materials in a secure location away from compressor.
<ul style="list-style-type: none">Restricting any of the compressor ventilation openings will cause serious overheating and could cause fire.	<ul style="list-style-type: none">Never place objects against or on top of compressor.Operate compressor in an open area at least 12" (30.5 cm) away from any wall or obstruction that would restrict the flow of fresh air to the ventilation openings.Operate compressor in a clean, dry well ventilated area. Do not operate unit indoors or in any confined area.
<ul style="list-style-type: none">Unattended operation of this product could result in personal injury or property damage. To reduce the risk of fire, do not allow the compressor to operate unattended.	<ul style="list-style-type: none">Always remain in attendance with the product when it is operating.Always turn off and unplug unit when not in use.

HAZARD



▲ DANGER: RISK TO BREATHING (ASPHYXIATION)

WHAT CAN HAPPEN	HOW TO PREVENT IT
<ul style="list-style-type: none">The compressed air directly from your compressor is not safe for breathing. The air stream may contain carbon monoxide, toxic vapors, or solid particles from the air tank. Breathing these contaminants can cause serious injury or death.	<ul style="list-style-type: none">Air obtained directly from the compressor should never be used to supply air for human consumption. In order to use air produced by this compressor for breathing, suitable filters and in-line safety equipment must be properly installed. In-line filters and safety equipment used in conjunction with the compressor must be capable of treating air to all applicable local and federal codes prior to human consumption.

- | | |
|--|--|
| <ul style="list-style-type: none"> • Exposure to chemicals in dust created by power sanding, sawing, grinding, drilling, and other construction activities may be harmful. • Sprayed materials such as paint, paint solvents, paint remover, insecticides, weed killers, may contain harmful vapors and poisons. | <ul style="list-style-type: none"> • Work in an area with good cross ventilation. Read and follow the safety instructions provided on the label or safety data sheets for the materials you are spraying. Always use certified safety equipment: NIOSH/OSHA respiratory protection or properly fitting face mask designed for use with your specific application. |
|--|--|

HAZARD



⚠ WARNING: RISK OF BURSTING

Air Tank: The air tank on your Air Compressor is designed and may be UM coded (for units with air tanks greater than 6" (122 mm) diameter) according to ASME Section VIII, Div. 1 rules. All pressure vessels should be inspected once every two years. To find your state pressure vessels inspector, look under the Division of Labor and Industries in the government section of a phone book .

The following conditions could lead to a weakening of the air tank, and result in a violent air tank explosion:

WHAT CAN HAPPEN	HOW TO PREVENT IT
<ul style="list-style-type: none"> • Failure to properly drain condensed water from air tank, causing rust and thinning of the steel air tank. 	<ul style="list-style-type: none"> • Drain air tank daily or after each use. If air tank develops a leak, replace it immediately with a new air tank or replace the entire compressor.
<ul style="list-style-type: none"> • Modifications or attempted repairs to the air tank. 	<ul style="list-style-type: none"> • Never drill into, weld, or make any modifications to the air tank or its attachments. Never attempt to repair a damaged or leaking air tank. Replace with a new air tank.
<ul style="list-style-type: none"> • Unauthorized modifications to the safety valve or any other components which control air tank pressure. 	<ul style="list-style-type: none"> • The air tank is designed to withstand specific operating pressures. Never make adjustments or parts substitutions to alter the factory set operating pressures.

Attachments & accessories:

- | | |
|--|---|
| <ul style="list-style-type: none"> • Exceeding the pressure rating of air tools, spray guns, air operated accessories, tires, and other inflatables can cause them to explode or fly apart, and could result in serious injury. | <ul style="list-style-type: none"> • Follow the equipment manufacturers recommendation and never exceed the maximum allowable pressure rating of attachments. Never use compressor to inflate small low pressure objects such as children's toys, footballs, basketballs, etc. |
|--|---|

Tires:

- Over inflation of tires could result in serious injury and property damage.
- Use a tire pressure gauge to check the tires pressure before each use and while inflating tires; see the tire sidewall for the correct tire pressure.
NOTE: Air tanks, compressors and similar equipment used to inflate tires can fill small tires similar to these very rapidly. Adjust pressure regulator on air supply to no more than the rating of the tire pressure. Add air in small increments and frequently use the tire gauge to prevent over inflation.

HAZARD



⚠️ WARNING: RISK OF ELECTRICAL SHOCK

WHAT CAN HAPPEN	HOW TO PREVENT IT
<ul style="list-style-type: none">• Your air compressor is powered by electricity. Like any other electrically powered device, If it is not used properly it may cause electric shock.	<ul style="list-style-type: none">• Never operate the compressor outdoors when it is raining or in wet conditions.• Never operate compressor with protective covers removed or damaged.
<ul style="list-style-type: none">• Repairs attempted by unqualified personnel can result in serious injury or death by electrocution.	<ul style="list-style-type: none">• Any electrical wiring or repairs required on this product should be performed by authorized service center personnel in accordance with national and local electrical codes.
<ul style="list-style-type: none">• Electrical Grounding: Failure to provide adequate grounding to this product could result in serious injury or death from electrocution. Refer to Grounding Instructions paragraph in the <i>Installation</i> section.	<ul style="list-style-type: none">• Make certain that the electrical circuit to which the compressor is connected provides proper electrical grounding, correct voltage and adequate fuse protection.

HAZARD



⚠ WARNING: RISK FROM FLYING OBJECTS

WHAT CAN HAPPEN	HOW TO PREVENT IT
<ul style="list-style-type: none">The compressed air stream can cause soft tissue damage to exposed skin and can propel dirt, chips, loose particles, and small objects at high speed, resulting in property damage or personal injury.	<ul style="list-style-type: none">Always wear certified safety equipment: ANSI Z87.1 eye protection (CAN/CSA Z94.3) with side shields when using the compressor.Never point any nozzle or sprayer toward any part of the body or at other people or animals.Always turn the compressor off and bleed pressure from the air hose and air tank before attempting maintenance, attaching tools or accessories.

HAZARD



⚠ WARNING: RISK OF HOT SURFACES

WHAT CAN HAPPEN	HOW TO PREVENT IT
<ul style="list-style-type: none">Touching exposed metal such as the compressor head, engine head, engine exhaust or outlet tubes, can result in serious burns.	<ul style="list-style-type: none">Never touch any exposed metal parts on compressor during or immediately after operation. Compressor will remain hot for several minutes after operation.Do not reach around protective shrouds or attempt maintenance until unit has been allowed to cool.

HAZARD



⚠ WARNING: RISK FROM MOVING PARTS

WHAT CAN HAPPEN	HOW TO PREVENT IT
<ul style="list-style-type: none">Moving parts such as the pulley, fly-wheel, and belt can cause serious injury if they come into contact with you or your clothing.	<ul style="list-style-type: none">Never operate the compressor with guards or covers which are damaged or removed.Keep your hair, clothing, and gloves away from moving parts. Loose clothes, jewelry, or long hair can be caught in moving parts.Air vents may cover moving parts and should be avoided as well.
<ul style="list-style-type: none">Attempting to operate compressor with damaged or missing parts or attempting to repair compressor with protective shrouds removed can expose you to moving parts and can result in serious injury.	<ul style="list-style-type: none">Any repairs required on this product should be performed by authorized service center personnel.

HAZARD



⚠ WARNING: RISK OF UNSAFE OPERATION

WHAT CAN HAPPEN	HOW TO PREVENT IT
<ul style="list-style-type: none">Unsafe operation of your air compressor could lead to serious injury or death to you or others.	<ul style="list-style-type: none">Review and understand all instructions and warnings in this manual.Become familiar with the operation and controls of the air compressor.Keep operating area clear of all persons, pets, and obstacles.Keep children away from the air compressor at all times.Do not operate the product when fatigued or under the influence of alcohol or drugs. Stay alert at all times.Never defeat the safety features of this product.Equip area of operation with a fire extinguisher.Do not operate machine with missing, broken, or unauthorized parts.

HAZARD



⚠ WARNING: RISK OF FALLING

WHAT CAN HAPPEN	HOW TO PREVENT IT
<ul style="list-style-type: none">A portable compressor can fall from a table, workbench, or roof causing damage to the compressor and could result in serious injury or death to the operator.	<ul style="list-style-type: none">Always operate compressor in a stable secure position to prevent accidental movement of the unit. Never operate compressor on a roof or other elevated position. Use additional air hose to reach high locations.

HAZARD



⚠ CAUTION: RISK FROM NOISE

WHAT CAN HAPPEN	HOW TO PREVENT IT
<ul style="list-style-type: none">Under some conditions and duration of use, noise from this product may contribute to hearing loss.	<ul style="list-style-type: none">Always wear certified safety equipment: ANSI S12.6 (S3.19) hearing protection.

**SAVE THESE INSTRUCTIONS
FOR FUTURE USE**

GLOSSARY

Become familiar with these terms before operating the unit.

CFM: Cubic feet per minute.

SCFM: Standard cubic feet per minute; a unit of measure of air delivery.

PSIG: Pounds per square inch gauge; a unit of measure of pressure.

Code Certification: Products that bear one or more of the following marks: UL, CUL, ETL, CETL, have been evaluated by OSHA certified independent safety laboratories and meet the applicable Underwriters Laboratories Standards for Safety.

Cut-In Pressure: While the motor is off, air tank pressure drops as you

continue to use your accessory. When the tank pressure drops to a certain low level the motor will restart automatically. The low pressure at which the motor automatically restarts is called "cut-in" pressure.

Cut-Out Pressure: When an air compressor is turned on and begins to run, air pressure in the air tank begins to build. It builds to a certain high pressure before the motor automatically shuts off, protecting your air tank from pressure higher than its capacity. The high pressure at which the motor shuts off is called "cut-out" pressure.

Branch Circuit: Circuit carrying electricity from electrical panel to outlet.

ACCESSORIES

This unit is capable of powering the following accessories. The accessories are available through the current Power and Hand Tool Catalog or full-line Sears stores.

Accessories

- In Line Filter
- Tire Air Chuck
- Quick Connector Sets (various sizes)
- Air Pressure Regulators
- Oil Fog Lubricators
- Air Hose: 1/4", 3/8" or 1/2" I.D. in various lengths

Refer to the selection chart located on the unit to select the tools this unit is capable of powering.

▲ WARNING: The use of any other accessory not recommended for use with this tool could be hazardous. Use only accessories rated equal to or higher than the rating of the air compressor.

DUTY CYCLE

This air compressor pump is capable of running continuously. However, to prolong the life of your air compressor, it is recommended that a 50%-75%

average duty cycle be maintained; that is, the air compressor pump should not run more than 30-45 minutes in any given hour.

ASSEMBLY

Unpacking

1. Remove unit from carton and discard all packaging.

INSTALLATION

HOW TO SET UP YOUR UNIT

Location of the Air Compressor

- Locate the air compressor in a clean, dry and well ventilated area.
- The air compressor should be located at least 12" (30.5 cm) away from the wall or other obstructions that will interfere with the flow of air.
- The air compressor pump and shroud are designed to allow for proper cooling. The ventilation openings on the compressor are necessary to maintain proper operating temperature. Do not place rags or other containers on or near these openings.

GROUNDING INSTRUCTIONS

⚠ WARNING Risk of Electrical Shock. In the event of a short circuit, grounding reduces the risk of shock by providing an escape wire for the electric current. This air compressor must be properly grounded.

The portable air compressor is equipped with a cord having a grounding wire with an appropriate grounding plug (see following illustrations).

1. The cord set and plug with this unit contains a grounding pin. This plug **MUST** be used with a grounded outlet.

IMPORTANT: The outlet being used must be installed and grounded in accordance with all local codes and ordinances.

2. Make sure the outlet being used has the same configuration as the grounded plug. **DO NOT USE AN ADAPTER.** See illustration.

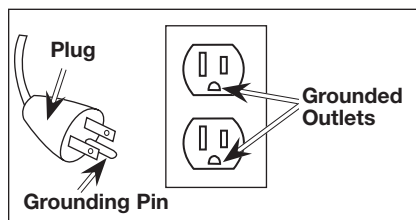

3. Inspect the plug and cord before each use. Do not use if there are signs of damage.
4. If these grounding instructions are not completely understood, or if in doubt as to whether the compressor is properly grounded, have the installation checked by a qualified electrician.

⚠ DANGER Risk of Electrical Shock. **IMPROPER GROUNDING CAN RESULT IN ELECTRICAL SHOCK.**

Do not modify the plug provided. If it does not fit the available outlet, a correct outlet should be installed by a qualified electrician.

Repairs to the cord set or plug MUST be made by a qualified electrician.

Extension Cords

If an extension cord must be used, be sure it is:

- a 3-wire extension cord that has a 3-blade grounding plug, and a 3-slot receptacle that will accept the plug on the product
- in good condition
- no longer than 50 feet
- 14 gauge (AWG) or larger. (Wire size increases as gauge number decreases. 12 AWG and 10 AWG may also be used. DO NOT USE 16 OR 18 AWG.)

CAUTION:

The use of an undersized

extension cord will cause voltage to drop resulting in power loss to the motor and overheating. Instead of using an extension cord, increase the working reach of the air hose by attaching another length of hose to its end. Attach additional lengths of hose as needed.

Voltage and Circuit Protection

Refer to the specification chart for the voltage and minimum branch circuit requirements.

CAUTION

Risk of Operation. Certain air compressors can be operated on a 15 amp circuit if the following conditions are met.

1. Voltage supply to circuit must comply with the National Electrical Code.
2. Circuit is not used to supply any other electrical needs.
3. Extension cords comply with specifications.
4. Circuit is equipped with a 15 amp circuit breaker or 15 amp time delay fuse. **NOTE:** If compressor is connected to a circuit protected by fuses, use only time delay fuses. Time delay fuses should be marked "D" in Canada and "T" in the US.

If any of the above conditions cannot be met, or if operation of the compressor repeatedly causes interruption of the power, it may be necessary to operate it from a 20 amp circuit. It is not necessary to change the cord set.

OPERATION

Know Your Air Compressor

READ THIS OWNER'S MANUAL AND SAFETY RULES BEFORE OPERATING YOUR UNIT. Compare the illustrations with your unit to familiarize yourself with the location of various controls and adjustments. Save this manual for future reference.

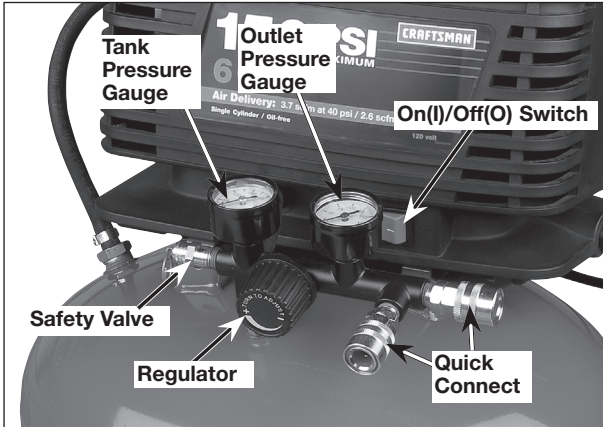

Description of Operation

Become familiar with these controls before operating the unit.

On(I)/Off(O) Switch: Place this switch in the On (I) position to provide automatic power to the pressure switch and Off (O) to remove power at the end of each use.

Pressure Switch (not shown): The pressure switch automatically starts the motor when the air tank pressure drops below the factory set "cut-in" pressure. It stops the motor when the air tank pressure reaches the factory set "cut-out" pressure.

Safety Valve: If the pressure switch does not shut off the air compressor at its "cut-out" pressure setting, the safety valve will protect against high pressure by "popping out" at its factory set pressure (slightly higher than the pressure switch "cut-out" setting).

Tank Pressure Gauge: The tank pressure gauge indicates the reserve air pressure in the tank.

Outlet Pressure Gauge: The outlet pressure gauge indicates the air pressure available at the outlet side of the regulator. This pressure is

controlled by the regulator and is always less than or equal to the tank pressure.

Regulator: Controls the air pressure shown on the outlet pressure gauge. Turn regulator knob clockwise to increase pressure and counterclockwise to decrease pressure.

Cooling System (not shown): This compressor contains an advanced design cooling system. At the heart of this cooling system is an engineered fan. It is perfectly normal for this fan to blow air through the vent holes in large amounts. You know that the cooling system is working when air is being expelled.

Air Compressor Pump (not shown): Compresses air into the air tank. Working air is not available until the compressor has raised the air tank pressure above that required at the air outlet.

Drain Valve: The drain valve is located at the base of the air tank and is used to drain condensation at the end of each use.



Check Valve: When the air compressor is operating, the check valve is "open", allowing compressed air to enter the air tank. When the air compressor reaches "cut-out" pressure, the check valve "closes", allowing air pressure to remain inside the air tank.



Motor Overload Protector (not shown): The motor has an automatic reset thermal overload protector. If the motor overheats for any reason, the overload protector will shut off the motor. The motor must be allowed to cool down before restarting. The compressor will automatically restart after the motor cools.

HOW TO USE YOUR UNIT

How to Stop

1. Set the On/Off switch to "Off" .

Before Starting

▲WARNING: Do not operate this unit until you read and understand this instruction manual for safety, operation and maintenance instructions.

Break-in Procedure

CAUTION Risk of Unsafe Operation. Serious damage may result if the following break-in instructions are not closely followed.

This procedure is required **before** the air compressor is put into service and when the check valve or a complete compressor pump has been replaced.

1. Make sure the On/Off switch is in the "Off" position.
2. Plug the power cord into the correct branch circuit receptacle. (Refer to **Voltage and Circuit Protection** paragraph in the *Installation* section of this manual.)

3. Open the drain valve (counter-clockwise) fully to permit air to escape and prevent air pressure build up in the air tank during the break-in period.
4. Move the On/Off switch to "On" position. The compressor will start.
5. Run the compressor for 15 minutes. Make sure the drain valve is open and there is minimal air pressure build-up in tank.
6. After 15 minutes, close the drain valve by turning clockwise. The air receiver will fill to "cut-out" pressure and the motor will stop.

The compressor is now ready for use.

Before Each Start-Up

1. Set the On/Off switch to "Off".
2. Turn the regulator knob counter-clockwise to set the outlet pressure to zero.
3. Attach hose and accessories.

▲WARNING Risk of unsafe operation. Firmly grasp air hose in hand when installing or disconnecting to prevent hose whip.

▲WARNING Risk of unsafe operation. Do not use damaged or worn accessories.

NOTE: The hose or accessory will require a quick connect plug if the air outlet is equipped with a quick connect socket.

▲WARNING Risk of Bursting. Too much air pressure causes a hazardous risk of bursting. Check the manufacturer's maximum pressure rating for air tools and accessories. The regulator outlet pressure must never exceed the maximum pressure rating.

▲CAUTION: Risk of unsafe operation. Compressed air from the unit may contain water condensation and oil mist. Do not spray unfiltered air at an item that could be damaged by moisture. Some air tools and accessories may require filtered air. Read the instructions for the air tools and accessories.

How to Start:

1. Set the On/Off switch to "On" and allow tank pressure to build. Motor will stop when tank pressure reaches "cut-out" pressure.
2. Turn regulator knob clockwise to increase pressure and stop when desired pressure is reached.

▲ WARNING If any unusual noise or vibration is noticed, stop the compressor immediately and have it checked by a trained service technician.

The compressor is ready for use.

MAINTENANCE

Customer Responsibilities

	Before each use	Daily or after each use
Check Safety Valve	X	
Drain Tank		X

▲ WARNING Unit cycles automatically when power is on. When performing maintenance, you may be exposed to voltage sources, compressed air, or moving parts. Personal injuries can occur. Before performing any maintenance or repair, disconnect power source from the compressor and bleed off all air pressure.

NOTE: See *Operation* section for the location of controls.

To Check Safety Valve

▲ WARNING: Risk of Bursting. If the safety valve does not work properly, over-pressurization may occur, causing air tank rupture or an explosion.

▲ WARNING: Risk from Flying Objects. Always wear certified safety equipment: ANSI Z87.1 eye protection (CAN/CSA Z94.3) with side shields

1. Before starting compressor, pull the ring on the safety valve to make sure that the safety valve operates freely. If the valve is stuck or does not operate smoothly, it must be replaced with the same type of valve.

To Drain Tank

▲ WARNING: Risk of Unsafe Operation. Risk from noise. Air tanks contain high pressure air. Keep face and other body parts away from outlet of drain. Use ANSI Z87.1 eye protection (CAN/CSA Z94.3) when draining as debris can be kicked up into face. Use ear protection [(ANSI S12.6 (S3.19))] hearing protection) as air flow noise is loud when draining.

1. Set the On/Off switch to "Off".
2. Turn the regulator knob counter-clockwise to set the outlet pressure to zero.
3. Remove the air tool or accessory.
4. Pull ring on safety valve allowing air to bleed from the tank until tank pressure is approximately 20 PSI. Release safety valve ring.
5. Drain water from air tank by opening drain valve on bottom of tank.

▲ WARNING: Risk of Bursting. Water will condense in the air tank. If not drained, water will corrode and weaken the air tank causing a risk of air tank rupture.

CAUTION: Risk of Property Damage. Drain water from air tank may contain oil and rust which can cause stains.

6. After the water has been drained, close the drain valve. The air compressor can now be stored.

NOTE: If drain valve is plugged, release all air pressure. The valve can then be removed, cleaned, the reinstalled.

SERVICE AND ADJUSTMENTS

ALL MAINTENANCE AND REPAIR OPERATIONS NOT LISTED MUST BE PERFORMED BY TRAINED SERVICE TECHNICIAN.

⚠ WARNING Risk of Unsafe Operation. Unit cycles automatically when power is on. When servicing, you may be exposed to voltage sources, compressed air, or moving parts. Before servicing unit unplug or disconnect electrical supply to the air compressor, bleed tank of pressure, and allow the air compressor to cool.

To Replace or Clean Check Valve

1. Release all air pressure from air tank. See **To Drain Tank** in the *Maintenance* section.
2. Unplug unit.
3. Remove the hose by removing the hose clamp. **NOTE:** The hose clamp is not reusable. You must purchase a new hose clamp, see the Parts List or purchase a standard hose clamp at a local hardware store.

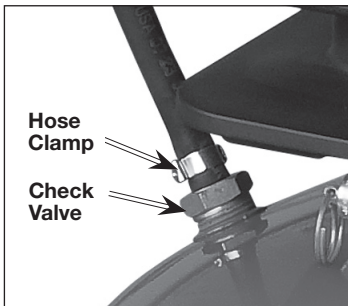

4. Unscrew the check valve (turn counter-clockwise) using a socket wrench.
5. Make sure the valve disc moves freely inside the check valve and the spring holds the disc in the upper, closed position. The check valve may be cleaned with a solvent, such as paint and varnish remover.

6. Apply sealant to the check valve threads. Reinstall the check valve (turn clockwise).
7. Replace hose and new hose clamp.
8. Perform the Break-in Procedure. See **Break-in Procedure** in the *Operation* section.

To Replace Regulator Manifold

1. Release all air pressure from air tank. See **To Drain Tank** in the *Maintenance* section.
2. Unplug unit.
3. Using an adjustable wrench remove the safety valve from the regulator manifold.

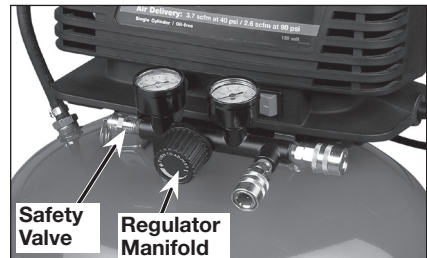

- Remove the hose by removing the hose clamp. **NOTE:** The hose clamp is not reusable. You must purchase a new hose clamp, see the Parts List or purchase a standard hose clamp at a local hardware store.

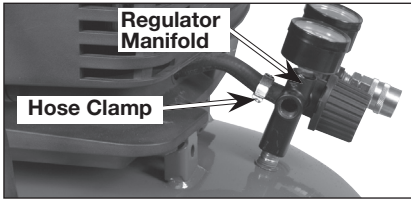

- Remove pump mounting screws securing pump (one on each side).

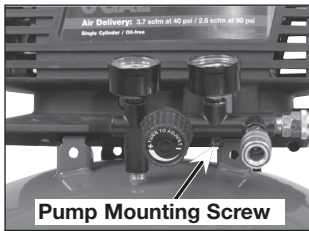

- Carefully slide pump from brackets and out of the way.

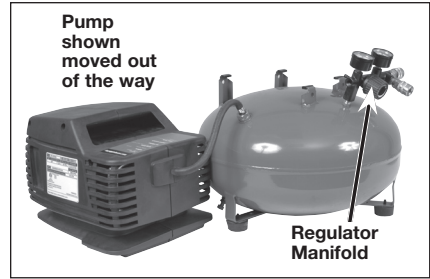

- Using an adjustable wrench remove the regulator manifold.
- Apply pipe sealant to new regulator manifold and assemble, tighten with wrench.
- Reapply pipe sealant to safety valve.
- Reassemble all components in reverse order of removal. Make sure to orient gauges to read correctly and use wrenches to tighten all components.

STORAGE

Before you store the air compressor, make sure you do the following:

- Review the Maintenance section on the preceding pages and perform scheduled maintenance as necessary.
- Set the On/Off switch to "Off" and unplug unit.
- Turn the regulator counterclockwise and set the outlet pressure to zero.
- Remove the air tool or accessory.
- Pull ring on safety valve allowing air to bleed from the tank until tank pressure is approximately 20 PSI. Release safety valve ring.
- Drain water from air tank by opening drain valve on bottom of tank.

⚠ WARNING

Risk of Bursting. Water will condense in the air tank. If not drained, water will corrode and weaken the air tank causing a risk of air tank rupture.

- After the water has been drained, close drain valve by turning clockwise.

NOTE: If drain valve is plugged, release all air pressure. The valve can then be removed, cleaned, then reinstalled.

- Protect the electrical cord and air hose from damage (such as being stepped on or run over). Wind them loosely around the compressor handle.
- Store the air compressor in a clean and dry location.

TROUBLESHOOTING

⚠ WARNING Risk of Unsafe Operation. Unit cycles automatically when power is on. When servicing, you may be exposed to voltage sources, compressed air, or moving parts. Before servicing unit unplug or disconnect electrical supply to the air compressor, bleed tank of pressure, and allow the air compressor to cool.

PROBLEM	CAUSE	CORRECTION
Excessive tank pressure - safety valve pops off.	<p>Pressure switch does not shut off motor when compressor reaches "cut-out" pressure.</p> <p>Pressure switch "cut-out" too high.</p>	<p>Move On/Off lever to the "Off" position, if the outfit does not shut off contact a Trained Service Technician.</p> <p>Contact a Trained Service Technician.</p>
Air leaks at fittings.	Tube fittings are not tight enough.	Tighten fittings where air can be heard escaping. Check fittings with soapy water solution. Do Not Overtighten.
Air leaks in air tank or at air tank welds.	Defective air tank.	<p>Air tank must be replaced. Do not repair the leak.</p> <p>⚠ WARNING: Risk bursting. Do not drill into, weld or otherwise modify air tank or it will weaken. The tank can rupture or explode.</p>
Air leaks between head and valve plate.	Leaking seal.	Contact a Trained Service Technician.
Air leak from safety valve.	Possible defect in safety valve.	Operate safety valve manually by pulling on ring. If valve still leaks, it should be replaced.
Knocking Noise.	Possible defect in safety valve.	Operate safety valve manually by pulling on ring. If valve still leaks, it should be replaced.

PROBLEM	CAUSE	CORRECTION
Pressure reading on the regulated pressure gauge drops when an accessory is used.	It is normal for "some" pressure drop to occur.	If there is an excessive amount of pressure drop when the accessory is used, adjust the regulator following the instructions in the Description of Operation paragraph in the <i>Operation</i> Section. NOTE: Adjust the regulated pressure under flow conditions (while accessory is being used).
Compressor is not supplying enough air to operate accessories.	<p>Prolonged excessive use of air.</p> <p>Compressor is not large enough for air requirement.</p> <p>Hole in hose.</p> <p>Check valve restricted.</p> <p>Air leaks.</p>	<p>Decrease amount of air usage.</p> <p>Check the accessory air requirement. If it is higher than the SCFM or pressure supplied by your air compressor, you need a larger compressor.</p> <p>Check and replace if required.</p> <p>Remove and clean, or replace.</p> <p>Tighten fittings.</p>
Regulator knob has continuous air leak.	Damaged regulator.	Replace.

PROBLEM	CAUSE	CORRECTION
Regulator will not shut off air outlet.	Damaged regulator.	Replace.
Motor will not run.	<p>Fuse blown, circuit breaker tripped.</p> <p>Extension cord is wrong length or gauge.</p> <p>Loose electrical connections.</p> <p>Faulty motor.</p> <p>Motor overload protection switch has tripped</p>	<p>Check fuse box for blown fuse and replace as necessary. Reset circuit breaker. Do not use a fuse or circuit breaker with higher rating than that specified for your particular branch circuit.</p> <p>Check for proper fuse. You should use a time delay fuse.</p> <p>Check for low voltage problem.</p> <p>Check the extension cord.</p> <p>Disconnect the other electrical appliances from circuit or operate the compressor on its own branch circuit.</p> <p>Check the extension cord.</p> <p>Check wiring connection inside terminal box.</p> <p>Have checked by a Trained Service Technician.</p> <p>Refer to Motor Overload Protection under <i>Operation</i>. If motor overload protection trips frequently, contact a Trained Service Technician.</p>

AIR COMPRESSOR DIAGRAM

Air Compressor Model Number 919.152160

PARTS SHOWN FOR REFERENCE ONLY

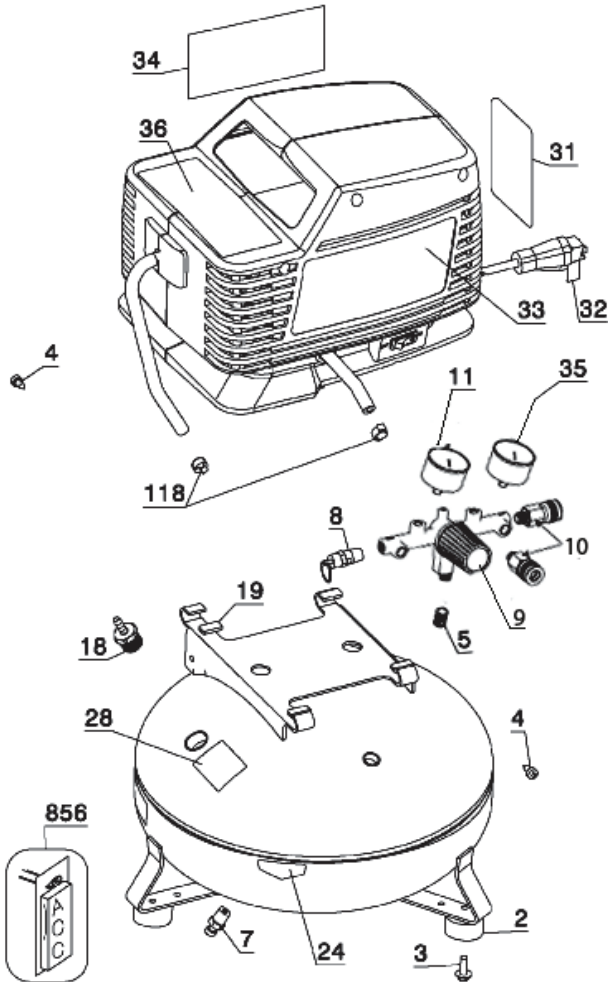

N014212

Air Compressor - MODEL NUMBER 919.15216

07/31/08

N014212

20 - ENG

PARTS LIST

Air Compressor Model Number 919.152160

ITEM NO.	PART NO.	DESCRIPTION	QTY
2	D24721	Isolator Kit	3
3	91895680	Screw	3
4	SSF-621	Screw	2
5	A14877	Nipple	1
7	A17038	Drain Valve	1
8	A17987	Safety Valve	1
9	1000002226	Manifold (incl. 5, 10, 11, 35)	1
10	A16182	Quick Connect Body	2
11	A17166	Gauge	1
18	A19714	Check Valve	1
19	CAC-1254	Pump Isolator	4
24	LA-3109	Drain Tank Warning Label	1
28	LA-3108	Hot Surface Label	1
31	LA-3270	Warning Label	1
32	LA-2876	Power Cord Label	1
33	1000003194	Identification Label	1
34	N014220	Nameplate	1
35	A17135	Gauge	1
36	1000002886	Rating Label	1

PUMP DIAGRAM

Air Compressor Model Number 919.152160

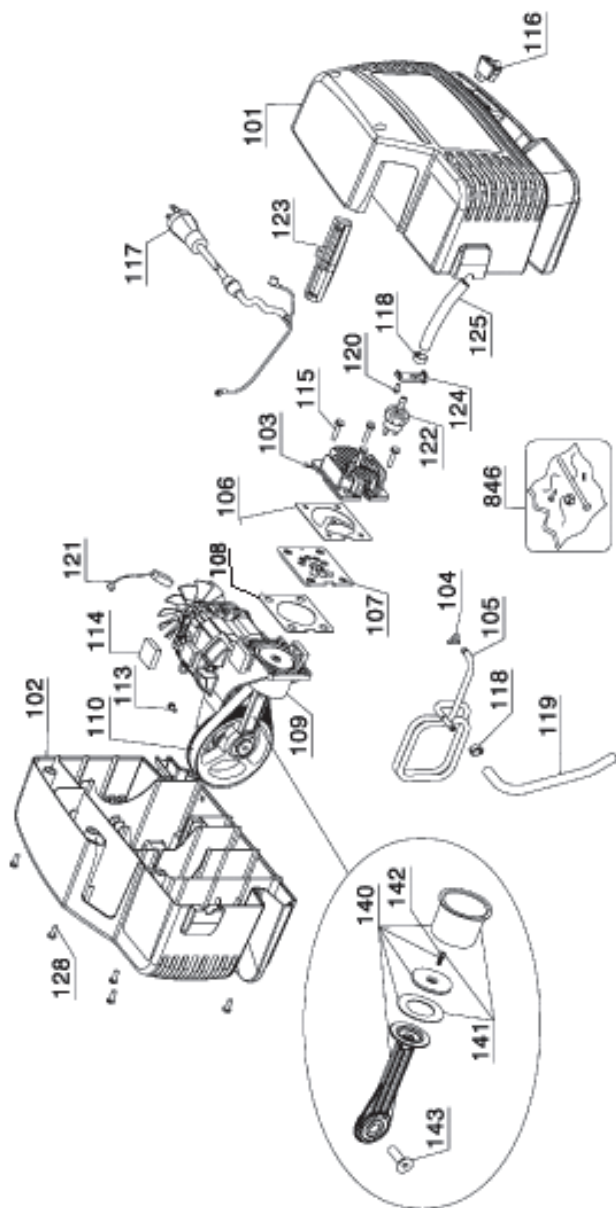

PARTS LIST

Air Compressor Model Number 919.152160

ITEM PART				
NO.	NO.	DESCRIPTION	QTY	
	101	1000002791	Shroud (Right)	1
	102	1000002792	Shroud (Left)	1
	103	D25877	Head	1
	104	CAC-1212	Seal	1
	105	D22253	Outlet Tube	1
	106	Z-D24819	Gasket Kit (Incl. 104)	1
	107	Z-A08548	Valve Plate Assembly	1
	108	A03865	Gasket	1
	109	Z-A04615	Pump	1
	110	AC-0815	Timing Belt	1
φ	113	SUDL-9-1	Screw	1
	114	D25731	Pump Isolator	5
φ	115	SSF-995	Screw	4
	116	A11027	Switch	1
	117	A04770	Cordset	1
	118	CAC-1206-1	Hose Clamp	4
	119	H-7051	Air Hose	1
	120	SSF-3156	Screw	1
	121	Z-D23825	Brush Motor (Ametek)	1
	121	Z-D27196	Brush Motor (Gold Tuning)	1
	122	N002119	Pressure Switch	1
	123	A00470	Support Handle	1
	124	A05239	Bracket	1
	125	A10162	Air Hose	1
	128	D29132	Screw	5
	140	KK-4964	Connecting Rod Kit	1
	141	D30324	Ring Kit	1
	142	D21127	Screw	1
φ	143	A19123	Screw	1
	846	KK-4929	Fastener Kit (Incl. 113,115, 128,143)	1
	856	AC-0625	Teflon Tape(not included)	1
	856	N004086	Air Hose	1
	856	1000000543	BlowGun Kit	1

φ NOTES:

- 113 Torque to 30-45 in.-lbs.
- 115 Torque to 49-55 in.-lbs.
- 143 Torque to 315-385 in.-lbs.

Master Protection Agreements

Congratulations on making a smart purchase. Your new Craftsman® product is designed and manufactured for years of dependable operation. But like all products, it may require preventive maintenance or repair from time to time. That's when having a Master Protection Agreement can save you money and aggravation.

Purchase a Master Protection Agreement now and protect yourself from unexpected hassle and expense.

The Master Protection Agreement also helps extend the life of your new product. Here's what's included in the Agreement:

- Expert service** by our 12,000 professional repair specialists
- Unlimited service and no charge** for parts and labor on all covered repairs
- "No-lemon" guarantee** – replacement of your covered product if four or more product failures occur within twelve months
- Product replacement** if your covered product can't be fixed
- Annual Preventive Maintenance Check** at your request – no extra charge
- Fast help by phone** - phone support from a Sears technician on products requiring in-home repair, plus convenient repair scheduling
- Power surge protection** against electrical damage due to power fluctuations
- Rental reimbursement** if repair of your covered product takes longer than promised

Once you purchase the Agreement, a simple phone call is all that it takes for you to schedule service. You can call anytime day or night, or schedule a service appointment online.

Sears has over 12,000 professional repair specialists, who have access to over 4.5 million quality parts and accessories. That's the kind of professionalism you can count on to help prolong the life of your new purchase for years to come. Purchase your Master Protection Agreement today!

Some limitations and exclusions apply. For prices and additional information call 1-800-827-6655.

Sears Installation Service

For Sears professional installation of home appliances, garage door openers, water heaters, and other major home items, in the U.S.A. call **1-800-4-MY-HOME®**

Contratos de Protección Maestra

Felicitaciones por hacer una compra inteligente. Su nueva unidad Craftsman® está diseñada y fabricada para años de operación confiable; pero como todos los productos de calidad, podría requerir reparaciones de vez en cuando. Ahí es cuando el Contrato de Protección Maestra le puede ahorrar dinero y molestias.

Compre ahora un Contrato de Protección Maestra y protéjase contra apuros y gastos inesperados.

El Contrato de Protección Maestra también permite prolongar la vida útil de su nueva unidad.

Este contrato incluye lo siguiente:

- Servicio Experto** a cargo de uno de nuestros 12.000 profesionales especializados en reparaciones.
- Servicio ilimitado sin cargo** por repuestos y mano de obra en todas las reparaciones cubiertas.
- Garantía por defectos de fábrica:** cubre el reemplazo de su unidad si dentro de los doce meses ocurren cuatro o más fallas.
- Reemplazo de la unidad** si su unidad cubierta no puede repararse.
- Control Anual de Mantenimiento Preventivo** a su solicitud, sin cargo adicional.
- Asistencia telefónica rápida** a cargo de personal técnico de soporte de Sears para las unidades que requieran repararse en su domicilio en horarios convenientes para usted.
- Protección contra los daños ocasionados** por sobretensión transitoria debido a fluctuaciones de energía.
- Reembolso de alquiler** si la reparación de su unidad cubierta lleva más tiempo del prometido.

Una vez que usted compre su Contrato, sólo necesita hacer una simple llamada telefónica para programar su servicio. Puede llamar a cualquier hora del día o la noche, o puede programar su servicio en línea vía Internet.

Sears tiene más de 12.000 profesionales especializados en reparaciones que tienen acceso a más 4,5 millones de repuestos y accesorios de calidad. Ése es el tipo de profesionalismo con el cual usted puede contar, que le ayudará a prolongar la vida útil de su unidad durante todos los años por venir. ¡Compre hoy su Contrato de Protección Maestra!

Se aplican algunas limitaciones y exclusiones. Para precios e información adicional, llame al 1-800-827-6655.

Servicio de Instalaciones de Sears

Para instalaciones profesionales de artefactos para el hogar a cargo de Sears, como abridores de puertas de garajes, calentadores de agua y otros artefactos grandes del hogar, en EE.UU. llame al **1-800-4-MY-HOME®**.

Get it fixed, at your home or ours!

Your Home

For repair – **in your home** – of **all** major brand appliances, lawn and garden equipment, or heating and cooling systems, **no matter who made it, no matter who sold it!**

For the replacement parts, accessories and owner's manuals that you need to do-it-yourself.

For Sears professional installation of home appliances and items like garage door openers and water heaters.

1-800-4-MY-HOME[®] Anytime, day or night
(1-800-469-4663) (U.S.A. and Canada)
www.sears.com **www.sears.ca**

Our Home

For repair of carry-in products like vacuums, lawn equipment, and electronics, call or go on-line for the nearest **Sears Parts and Repair Center.**

1-800-488-1222 Anytime, day or night (U.S.A. only)
www.sears.com

To purchase a protection agreement (U.S.A.) or maintenance agreement (Canada) on a product serviced by Sears:

1-800-827-6655 (U.S.A.)

1-800-361-6665 (Canada)

Para pedir servicio de reparación a domicilio, y para ordenar piezas:

1-888-SU-HOGARSM
(1-888-784-6427)

Au Canada pour service en français:

1-800-LE-FOYER^{MC}
(1-800-533-6937)
www.sears.ca

SEARS

© Sears, Roebuck and Co.

® Registered Trademark / TM Trademark / SM Service Mark of Sears, Roebuck and Co.

® Marca Registrada / TM Marca de Fábrica / SM Marca de Servicio de Sears, Roebuck and Co.

^{MC} Marque de commerce / ^{MD} Marque déposée de Sears, Roebuck and Co.