

Backhoes

BH3512

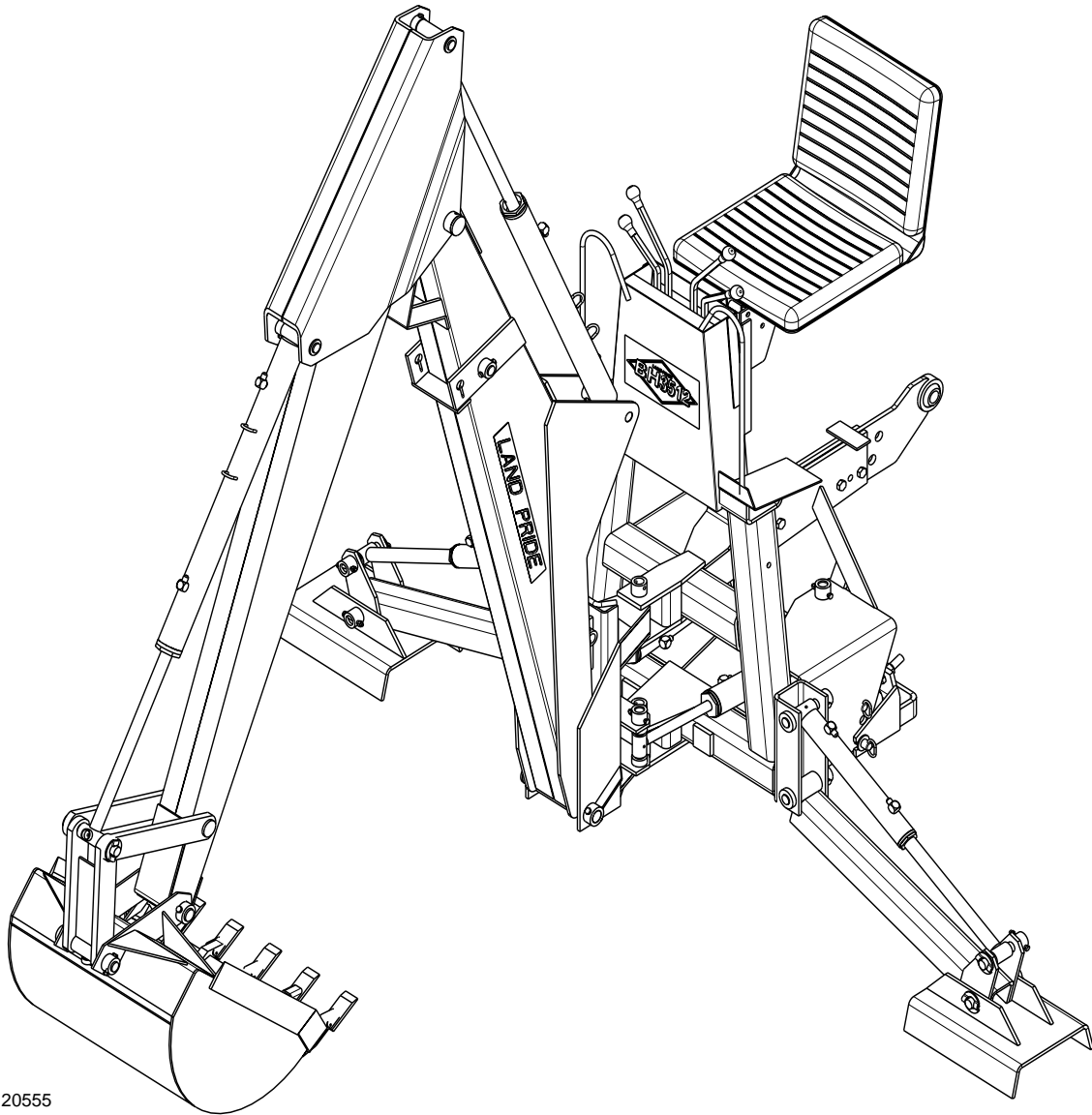

20555

340-131M Operator's Manual



Read the Operator's manual entirely. When you see this symbol, the subsequent instructions and warnings are serious - follow without exception. Your life and the lives of others depend on it!



© Copyright 2008 Printed 7/14/08

Cover photo may show optional equipment not supplied with standard unit.

Important Safety Information	1	Section 2: Operating Instructions	17
Safety at All Times	1	Preparing For Operation	17
Look For The Safety Alert Symbol	1	Preparing The Backhoe	17
Safety Labels	4	Preparing The Tractor	17
Introduction	6	Operating The Backhoe	17
Application	6	Transporting The Backhoe	17
Using This Manual	6	Control Functions	18
Terminology	6	Stabilizers	18
Definitions	6	Boom	18
Owner Assistance	6	Dipper Stick And Bucket	18
Serial Number Plate	6	Digging Suggestions	19
Further Assistance	6	Digging at the Correct Angle	19
Backhoe Operation, Maintenance & Safety Tips	7	Section 3: Maintenance and Lubrication 21	
Section 1: Assembly and Set-Up	8	Maintenance	21
Tractor Requirements	8	Storage	21
Hydraulic System Requirements	8	Bucket Tooth Replacement	21
Open Center System	8	Lubrication	22
Closed Center System	8	Bucket Pivot	22
Power Beyond Closed Center Kit Part No. 340-084A	8	Bucket Cylinder Base End	22
Power Beyond Hydraulic System	9	Dipper Stick Pivots	22
Power Beyond Closed Center Kit Part No. 340-084A	9	Boom Cylinder Rod End	23
Choose the Appropriate Hosing.	9	Boom Pivot	23
Independent P.T.O. Hydraulic Pump System	9	Boom Cylinder Base End	23
Testing Procedure for Hydraulic Circuits	11	Stabilizer Arms	24
Testing Open Center System	11	Boom Swing Cylinder Rod End	24
Checking a Single Circuit	11	Boom Swing Cylinder Base End	24
Checking the Cylinders	12	Section 4: Specifications & Capacities 25	
Return Hose:	12	Section 5: Features and Benefits	26
Testing Closed Center System	12	Section 6: Troubleshooting	27
Checking a Single Circuit	12	Section 7: Appendix	29
Checking the Pump	12	Torque Values Chart	29
Checking The Cylinders	12	Notes	30
Using Tractor Hydraulics All Tractors	13	Warranty	31
Using Tractor Hydraulics John Deere	13		
Mounting The Backhoe	13		
Description of Major Backhoe Parts	13		
Bucket Installation	16		
Locking Bar Installation (Optional)	16		
Seat Assembly	16		

© Copyright 2008 All rights Reserved

Land Pride provides this publication "as is" without warranty of any kind, either expressed or implied. While every precaution has been taken in the preparation of this manual, Land Pride assumes no responsibility for errors or omissions. Neither is any liability assumed for damages resulting from the use of the information contained herein. Land Pride reserves the right to revise and improve its products as it sees fit. This publication describes the state of this product at the time of its publication, and may not reflect the product in the future.

Land Pride is a registered trademark.

All other brands and product names are trademarks or registered trademarks of their respective holders.

Printed in the United States of America.

Important Safety Information

These are common practices that may or may not be applicable to the products described in this manual.

Safety at All Times

Thoroughly read and understand the instructions given in this manual before operation. Refer to the "Safety Label" section, read all instructions noted on them.

Do not allow anyone to operate this equipment who has not fully read and comprehended this manual and who has not been properly trained in the safe operation of the equipment.

- ▲ Operator should be familiar with all functions of the unit.
- ▲ Operate implement from the driver's seat only.
- ▲ Make sure all guards and shields are in place and secured before operating the implement.
- ▲ Do not leave tractor or implement unattended with engine running.
- ▲ Dismounting from a moving tractor could cause serious injury or death.
- ▲ Do not stand between the tractor and implement during hitching.
- ▲ Keep hands, feet, and clothing away from power-driven parts.
- ▲ Wear snug fitting clothing to avoid entanglement with moving parts.
- ▲ Watch out for wires, trees, etc., when raising implement. Make sure all persons are clear of working area.
- ▲ Turning tractor too tight may cause implement to ride up on wheels. This could result in injury or equipment damage.

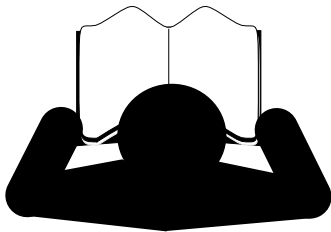

Look For The Safety Alert Symbol

The SAFETY ALERT SYMBOL indicates there is a potential hazard to personal safety involved and extra safety precaution must be taken. When you see this symbol, be alert and carefully read the message that follows it. In addition to design and configuration of equipment, hazard control and accident prevention are dependent upon the awareness, concern, prudence and proper training of personnel involved in the operation, transport, maintenance and storage of equipment.

Be Aware of Signal Words

A Signal word designates a degree or level of hazard seriousness. The signal words are:

DANGER

Indicates an imminently hazardous situation which, if not avoided, will result in death or serious injury. This signal word is limited to the most extreme situations, typically for machine components that, for functional purposes, cannot be guarded.

WARNING

Indicates a potentially hazardous situation which, if not avoided, could result in death or serious injury, and includes hazards that are exposed when guards are removed. It may also be used to alert against unsafe practices.

CAUTION

Indicates a potentially hazardous situation which, if not avoided, may result in minor or moderate injury. It may also be used to alert against unsafe practices.

For Your Protection

- ▲ Thoroughly read and understand the "Safety Label" section, read all instructions noted on them.

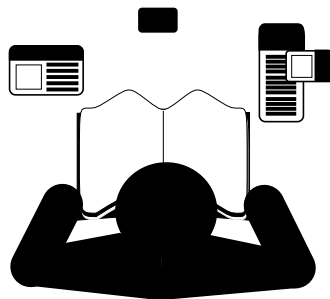

Shutdown and Storage

- ▲ Lower machine to ground, put tractor in park, turn off engine, and remove the key.
- ▲ Detach and store implements in a area where children normally do not play. Secure implement by using blocks and supports.

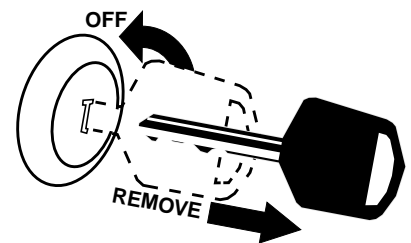

Important Safety Information

These are common practices that may or may not be applicable to the products described in this manual.

Use Safety Lights and Devices

- ▲ Slow moving tractors, self-propelled equipment, and towed implements can create a hazard when driven on public roads. They are difficult to see, especially at night.
- ▲ Flashing warning lights and turn signals are recommended whenever driving on public roads.

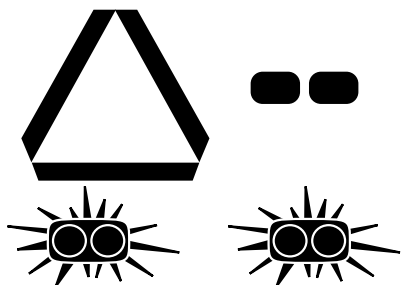

Transport Machinery Safely

- ▲ Comply with state and local laws.
- ▲ Maximum transport speed for implement is 20 mph. **DO NOT EXCEED.** Never travel at a speed which does not allow adequate control of steering and stopping. Some rough terrain require a slower speed.
- ▲ Sudden braking can cause a towed load to swerve and upset. Reduce speed if towed load is not equipped with brakes.
- ▲ Use the following maximum speed - tow load weight ratios as a guideline:

20 mph when weight is less than or equal to the weight of tractor.

10 mph when weight is double the weight of tractor.

IMPORTANT: Do not tow a load that is more than double the weight of tractor.

Transporting the Loader and Attachment

- ▲ Always drive up the ramp with heavy end uphill. Engage parking brake.
- ▲ Secure loader and attachments using tiedowns and chains. Use towing vehicle and trailer of adequate capacity.

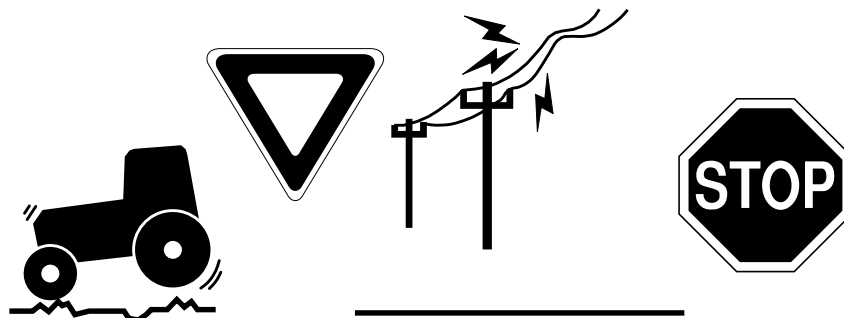

Practice Safe Maintenance

- ▲ Understand procedure before doing work. Use proper tools and equipment, refer to Operator's Manual for additional information.
- ▲ Work in a clean dry area.
- ▲ Lower the implement to the ground, put tractor in park, turn off engine, and remove key before performing maintenance.

- ▲ Allow implement to cool completely.
- ▲ Do not grease or oil implement while it is in operation.
- ▲ Inspect all parts. Make sure parts are in good condition & installed properly.
- ▲ Remove buildup of grease, oil or debris.
- ▲ Remove all tools and unused parts from implement before operation.

**Tractors With Cabs
Tractors Equipped With ROPS**

- ▲ There should be sufficient clearance for the operator when mounted to a tractor with a cab or that is equipped with ROPS.
- ▲ The ROPS may need to be extended or flipped around to obtain sufficient clearance.



Important Safety Information

These are common practices that may or may not be applicable to the products described in this manual.

Prepare for Emergencies

- ▲ Be prepared if a fire starts.
- ▲ Keep a first aid kit and fire extinguisher handy.
- ▲ Keep emergency numbers for doctor, ambulance, hospital and fire department near phone.

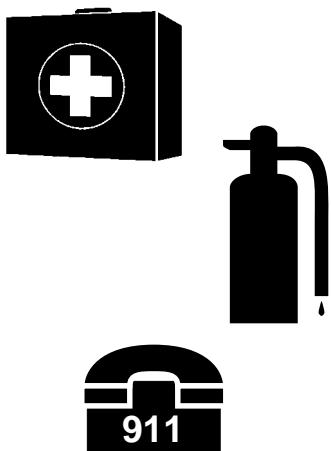

Wear Protective Equipment

- ▲ Protective clothing and equipment should be worn.
- ▲ Wear clothing and equipment appropriate for the job. Avoid loose fitting clothing.
- ▲ Prolonged exposure to loud noise can cause hearing impairment or hearing loss. Wear suitable hearing protection such as earmuffs or earplugs.
- ▲ Operating equipment safely requires the full attention of the operator. Avoid wearing radio headphones while operating machinery.



Keep Riders Off Machinery

- ▲ Riders obstruct the operator's view, they could be struck by foreign objects or thrown from the machine.
- ▲ Never allow children to operate equipment.

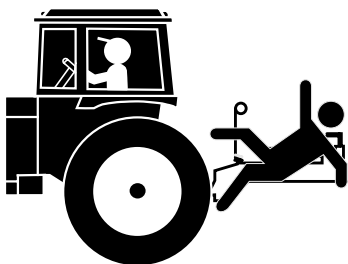

Avoid High Pressure Fluids Hazard

- ▲ Escaping fluid under pressure can penetrate the skin causing serious injury.
- ▲ Avoid the hazard by relieving pressure before disconnecting hydraulic lines.
- ▲ Use a piece of paper or cardboard, NOT BODY PARTS, to check for suspected leaks.
- ▲ Wear protective gloves and safety glasses or goggles when working with hydraulic systems.
- ▲ If an accident occurs, see a doctor immediately. Any fluid injected into the skin must be surgically removed within a few hours or gangrene may result.

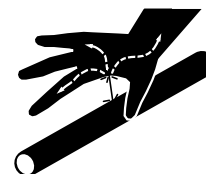

Important Safety Information

Safety Labels

Your backhoe comes equipped with all safety labels in place. They were designed to help you safely operate your implement. Read and follow their directions.

1. Keep all safety labels clean and legible.
2. Replace all damaged or missing labels. To order new labels go to your nearest Land Pride dealer.
3. Some new equipment installed during repair requires safety labels to be affixed to the replaced component as specified by Land Pride. When ordering new components

make sure the correct safety labels are included in the request.

4. Refer to this section for proper label placement. To install new labels:
 - a. Clean the area the label is to be placed.
 - b. Spray soapy water on the surface where the label is to be placed.
 - c. Peel backing from label. Press firmly onto the surface.
 - d. Squeeze out air bubbles with the edge of a credit card.

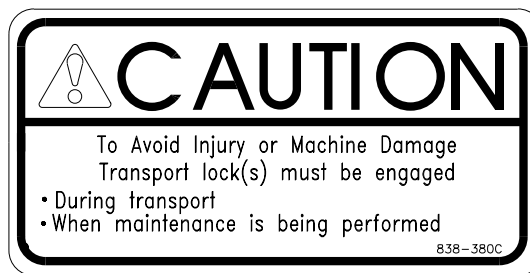
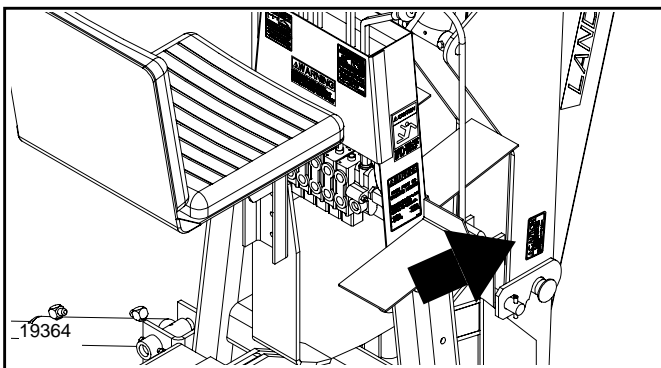

838-380C

Caution: Lock For Transport

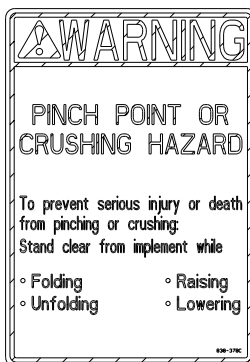
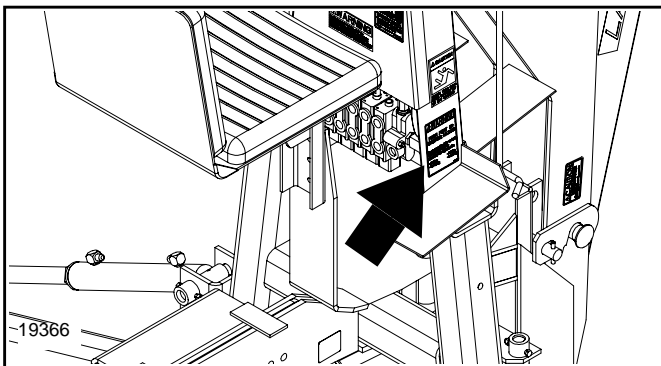

838-378C

Warning: Pinch or Crush Hazard

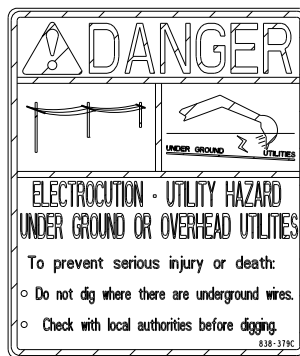
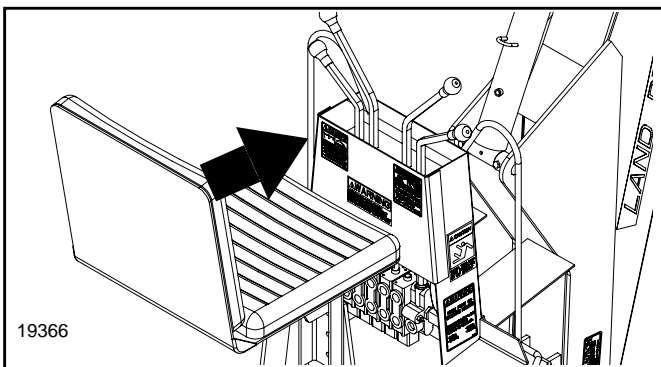

838-379C

Danger: Overhead/
Underground Utilities

Important Safety Information

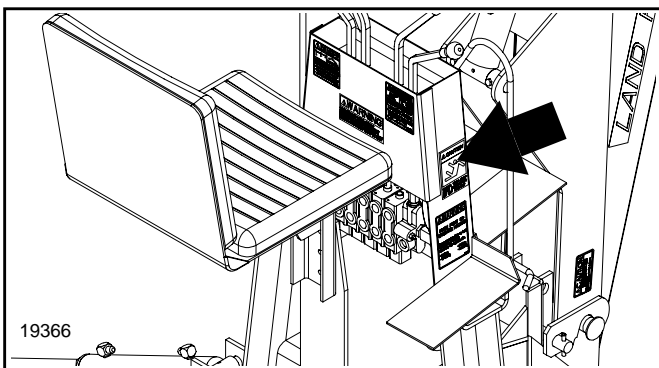
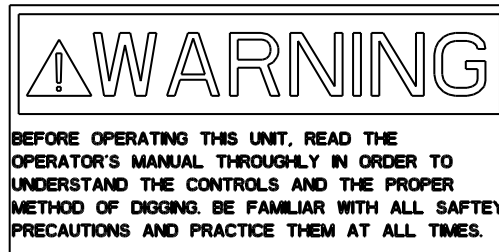
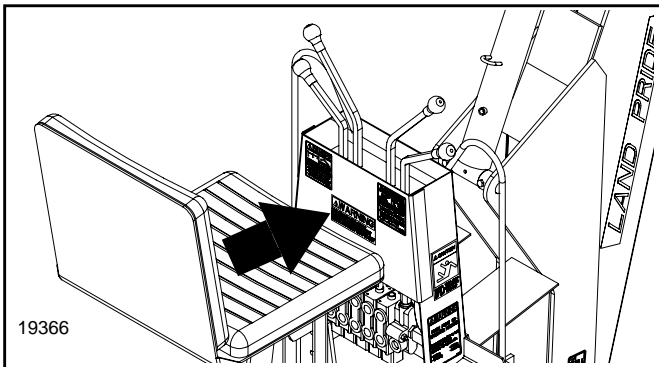
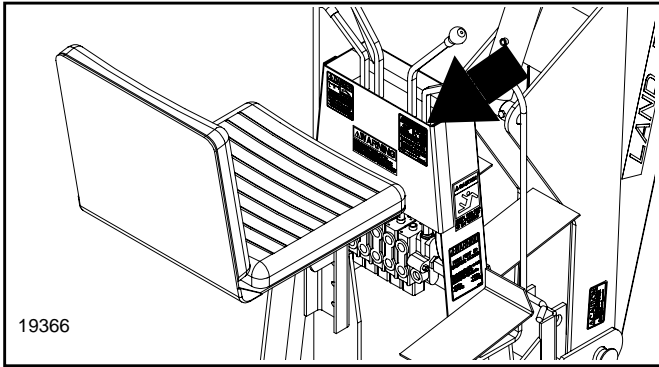

Introduction

Land Pride welcomes you to the growing family of new product owners.

This Backhoe has been designed with care and built by skilled workers using quality materials. Proper assembly, maintenance, and safe operating practices will help you get years of satisfactory use from the machine.

Application

The BH3512 Backhoe is the ideal tool for farms, drainage ditches, nurseries, golf courses, utilities and cemeteries. An unobstructed view of the work area, comfortable positioning of the controls and walk through platform allow for hours of fatigue free work. Stabilizer legs provide a stance of 10' 7" assuring more stability and safer operational control. Optional rubber shoes can be added to the stabilizer legs for working on concrete. Selected skid steer loader mounting kits are available for added versatility. See "**Features and Benefits**", "**Section 6**" for additional information.

Using This Manual

- This Operator's Manual is designed to help familiarize you with safety, assembly, operation, adjustments, troubleshooting, and maintenance. Read this manual and follow the recommendations to help ensure safe and efficient operation.
- The information contained within this manual was current at the time of printing. Some parts may change slightly to assure you of the best performance.
- To order a new Operator's or Parts Manual contact your authorized dealer. Manuals can also be downloaded, free-of-charge from our website at www.landpride.com or printed from the Land Pride Service & Support Center by your dealer.

Terminology

"Right" or "Left" as used in this manual is determined by facing the direction the machine will operate while in use unless otherwise stated.

Definitions

NOTE: A special point of information that the operator must be aware of before continuing.

IMPORTANT: A special point of information related to its preceding topic. Land Pride's intention is that this information should be read and noted before continuing.

Owner Assistance

The Warranty Registration card should be filled out by the dealer at the time of purchase. This information is necessary to provide you with quality customer service.

If customer service or repair parts are required contact a Land Pride dealer. A dealer has trained personnel, repair

parts and equipment needed to service the backhoe.

The parts on your backhoe have been specially designed and should only be replaced with genuine Land Pride parts. Therefore, should your backhoe require replacement parts go to your Land Pride Dealer.

Serial Number Plate

For prompt service always use the serial number and model number when ordering parts from your Land Pride dealer. Be sure to include your serial and model numbers in correspondence also. Refer to Figure 1 for the location of your serial number plate.

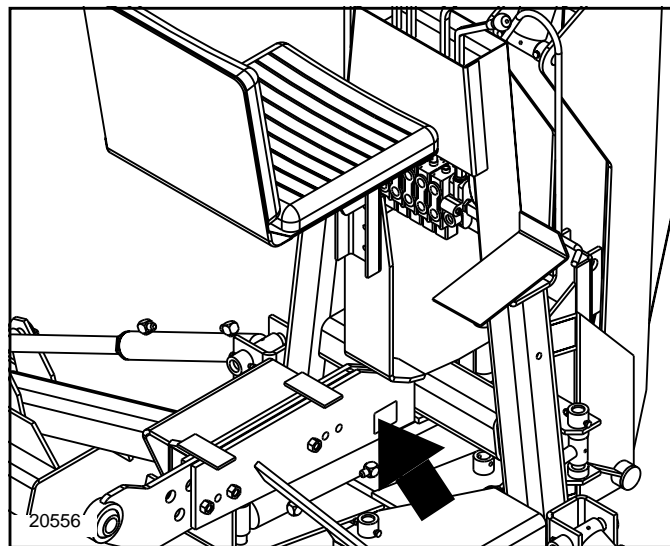

Serial Number Plate Location
Figure 1

Further Assistance

Your dealer wants you to be satisfied with your new backhoe. If for any reason you do not understand any part of this manual or are not satisfied with the service received, the following actions are suggested:

1. Discuss the matter with your dealership service manager making sure he is aware of any problems you may have and that he has had the opportunity to assist you.
2. If you are still not satisfied, seek out the owner or general manager of the dealership, explain the problem and request assistance.
3. For further assistance write to:

Land Pride Service Department
1525 East North Street
P.O. Box 5060
Salina, Ks. 67402-5060

E-mail address
lp servicedept@landpride.com

Introduction**Backhoe Operation, Maintenance & Safety Tips**

1. Your backhoe must be mounted only on a tractor equipped with a Category 1 or 2 hitch or Skid Steer Hitch. Failure to do so may result in serious injury.
2. When servicing the backhoe, make sure all moving parts are on the ground.
3. To avoid injury from escaping pressurized hydraulic fluid, move the control levers in all directions before disconnecting any hoses, steel lines, or couplers.
4. Keep footpads clean to prevent feet from slipping while mounting backhoe.
5. Do not transport your backhoe with the bucket fully raised.
6. Be sure your tractor has sufficient front end weight to operate and transport the backhoe.
7. When traveling on highways and roads, be sure the boom and stabilizers are in the fully raised position and transport lock is in the transport lock position.
8. When traveling on a road with your backhoe, use proper safety lights and warning sign. Check local regulations.
9. When traveling with your backhoe, do not make sudden starts, stops or turn at high speeds. Do not exceed safe speed limits on rough ground. Do not make sudden starts when climbing grades.
10. Always wear protective headgear while operating backhoe.
11. Be sure to lower the stabilizers to the ground before operating the backhoe.
12. Lookout for overhead low hanging wires. Do not touch wires with any part of the backhoe.
13. Do not operate from any position other than the backhoe's operator's seat.
14. Before swinging the backhoe for any reason, make sure you have room to swing and that all persons are clear of the backhoe.
15. Be extra careful when working on hillsides and close to ditches or any place where danger of tipping or sliding is possible.
16. Do not dig under the stabilizers or backhoe, as a cave-in could occur.
17. Be sure you are not digging over underground wiring or other underground obstructions.
18. When digging to either side and close to the tractor, be extremely careful that the backhoe does not contact the stabilizers as serious damage could occur.
19. Do not attempt to raise the tractor off the ground or move the tractor forward or backward using the boom or stabilizers.
20. When leaving the backhoe for any reason, lower the bucket to the ground for safety.
21. Never leave the backhoe unattended with tractor engine running.
22. To prevent injury during assembly, installation, operation, adjustment, or removal of the backhoe, it is recommended that gloves, safety glasses or face shield, and safety toe shoes be worn.
23. Do not wear loose clothing while operating or working near the backhoe. Keep hair and clothing away from all moving parts of the backhoe.
24. Only the operator should be near the backhoe during operation. Keep all others a minimum of fifty feet away from your work area.
25. Keep your work area clear of obstacles at all times.
26. Children should never be permitted to operate the backhoe.
27. Do not attempt any repairs, maintenance, or adjustments of your backhoe while it is in operation. Always turn off your tractor before making repairs or adjustments or performing maintenance procedures.
28. When the use of hand tools is required to perform any part of assembly, installation, removal or adjustment of the backhoe, be sure that the tools are designed and recommended by the tool manufacturer for the specific task in which they are being used.
29. Keep all bolts and nuts tight. Replace any damaged or worn parts such as hydraulic hoses and fittings immediately. Always use Land Pride replacement parts.
30. Perform all maintenance procedures as recommended.
31. Anytime hoses are disconnected from your backhoe, cover all open ports with protective caps or plugs in order to prevent contamination of the oil supply.

IMPORTANT: Make sure that there is sufficient clearance for the operator if the backhoe is mounted to a tractor with a cab or is equipped with a ROPS. The ROPS may need to be extended or flipped around to obtain sufficient clearance.

Tractor Requirements

CAUTION!

Your backhoe must be mounted only on a tractor equipped with a Category 2 and 3 hitch. Failure to do so may result in serious injury.

NOTE: In order to maintain steering control on your tractor, ballast may need to be added to your tractor. To determine whether or not to add the ballast, refer to your tractor's operator manual.

Hydraulic System Requirements

CAUTION!

The backhoe valve must be compatible with the hydraulic system that will power it. Make sure that if you are powering the backhoe with an open center hydraulic system, the backhoe is set for open center operation. If you are using a closed center hydraulic system, the valve must be set for closed center operation. If you are using a power beyond setup, the valve must be converted for this use. See the appropriate section of this manual on how to convert your valve. If you do not know how your valve is currently setup, check with your Land Pride dealer.

Your backhoe cylinders have been filled with oil at the factory. The oil in the unit is compatible with most tractor manufacturers' oil. Do not move any control levers on the unit until after hydraulic connections to the tractor or the independent hydraulic system have been made.

The Land Pride Backhoe has been designed to be operated at a flow rate of 8-11 GPM.

Since many tractor systems exceed a flow rate specified for your backhoe, the flow may have to be adjusted by throttling the engine RPM down to obtain an acceptable flow rate. By adjusting the flow rate correctly, you will prevent sudden shock loads on the cylinders, pins, hoses seals, etc. This results in a smooth operation and reduced maintenance costs and down time.

Open Center System

Remove cap from the 1/2" high pressure hose connected to the right hand side of backhoe valve. The high pressure hose may be connected to any high pressure outlet in the tractor system. A tractor remote hydraulic valve is usually the preferable source. An oil quick coupler that is compatible to the oil coupler on the tractor valve is permissible.

The return hose must be connected so that the oil returns directly to the tractor oil sump. DO NOT connect the return hose directly to the tractor remote valve. If the operator would be reversed. This could result in damage to the return hose or the backhoe's hydraulic valve.

CAUTION!

The hydraulic valve can be damaged by reverse flow of oil through the valve, disconnecting the return hose while the tractor is running, and by using more than 12 GPM of oil flow while operating. The valve manufacturer will not warrant the valve when damaged under these circumstances.

Closed Center System

Power Beyond Closed Center Kit Part No. 340-084A

CAUTION!

*If you are going to use a closed center tractor hydraulic system to power your **Land Pride Backhoe**, A Power Beyond and Closed Center Kit must be purchased from your **Land Pride Dealer**, then you must follow carefully the directions below. Failure to do so may cause extensive damage to your tractor and/or **Land Pride Backhoe**.*

Section 1: Assembly and Set-Up

Refer to Figure 1-1:

1. Adjust the Valve Bypass for Closed Center Conversion only.
 - a. Remove the cover nut (#3) from the valve bypass. This exposes a socket head screw.
 - b. Loosen locknut and turn socket head screw in approximately four complete turns, then tighten locknut.
 - c. Replace cover nut. Be sure to replace the washer with the cover nut as it acts as a gasket.
2. Installing the Closed Center Sleeve.
 - a. Return hose must be connected to the return section of the valve at point "A" and with the other end to the tractor.
 - b. Remove elbow at point "B" and install the closed center sleeve (#1). Use the plug (#2) that was removed from port "A" to plug the sleeve.
 - c. With the removal of the O-Ring plug from the front of outlet section of the valve Point "A" and replace with a 839-768C O-Ring adapter. Connect return line to the adapter and return to oil sump of the tractor.

19516

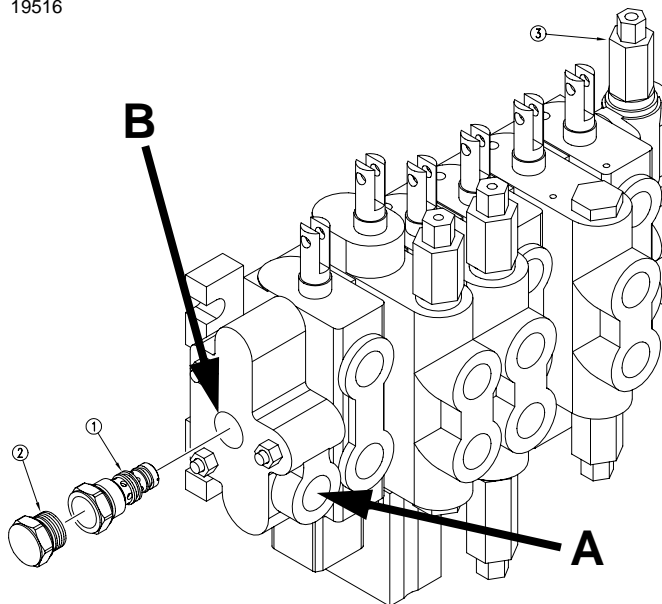

Closed Center Hydraulic Systems
Figure 1-1

This procedure converts the valve to a closed center operation. If the valve is set for closed center operation, it may be converted back to open center by reversing the above procedure.

Power Beyond Hydraulic System

If you wish to run both a loader and a backhoe from the same hydraulic system, make your connection as illustrated in Figure 1-2. Since there are so many variations for this type of setup, we are showing only a generalized hosing scheme. If you have any questions concerning the specifics for your situation, please contact your dealer before attempting operation.

Power Beyond Closed Center Kit Part No. 340-084A

For power beyond applications, a Power Beyond and Closed Center Kit (Part # 340-084A) must be purchased from your Land Pride Dealer, then perform the following steps:

3. Remove return hose and elbow, only if it was installed at point "B".
4. Remove plug (#4) from port "A" and install Power beyond sleeve (#1) in port "B" as shown in Figure 1-2.
5. Install a #8 O-Ring ell (Part # 839-882C) (#2) into closed center sleeve (#1) opening. This converts it to a power beyond sleeve.
6. Install a high pressure hose going to the inlet of another valve (front loader valve). This hose is not furnished.
7. If the return hose was installed at Point "B" it must be relocated and installed at point "A" of the outlet section. Remove the O'Ring plug and install one 839-768C adapter. Connect the return hose to the elbow and the other end to the oil sump of the tractor.

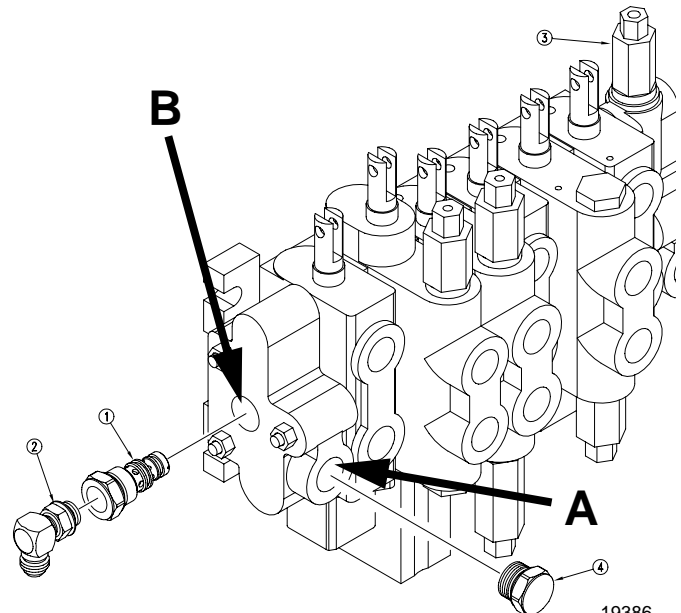

Power Beyond Hydraulic Systems
Figure 1-2

19386

Choose the Appropriate Hosing.

Independent P.T.O. Hydraulic Pump System

Install the independent hydraulic system onto the backhoe according to the following procedures. Refer to Figure 1-3 and Figure 1-4 for the identification of the parts. During the assembly, use pipe compound on all pipe fittings. None is required on the O-Ring fittings.

- a. Insert the filter into the SUCTION PORT of the reservoir. This is the port that is located on the left side of the reservoir.

Section 1: Assembly and Set-Up

- b. Attach the 1/2" street ell to the RETURN PORT on the reservoir. This is the port located on the right side of the reservoir.
- c. Attach the reservoir to the backhoe as shown in the drawings that come with the pump kit.
- d. Bolt the torque bar to the flange mounting of the pump. Use the bolts, lock washers and nuts supplied.
- e. Connect all fittings as illustrated in the instruction with the PTO hydraulic pump kit for your backhoe.

CAUTION!

Do not connect the pressure supply hose to return port of the backhoe valve. This will destroy a hydraulic pump in seconds.

CAUTION!

This power beyond circuit should be used only when powering your tractor and backhoe from a tractor internal system where you have relief valve protection of the pump. If it is used on an external pump, disconnection of any quick-coupler with the engine running will result in almost certain pump damage.

CAUTION!

The hydraulic valve can be damaged by:

1. Reversing the flow of oil through the valve.
2. Hydraulic lines disconnected during transport.
3. Disconnecting the return line while the tractor is running.
4. A faulty quick coupler.
5. More than 12 GPM of oil flow while operating the backhoe.
6. By connecting the backhoe to a tractor valve and actuating the valve in the wrong direction causing a reverse flow through the backhoe valve.

IMPORTANT: If removing backhoe from tractor, quick coupler reconnections should be made with tractor engine off.

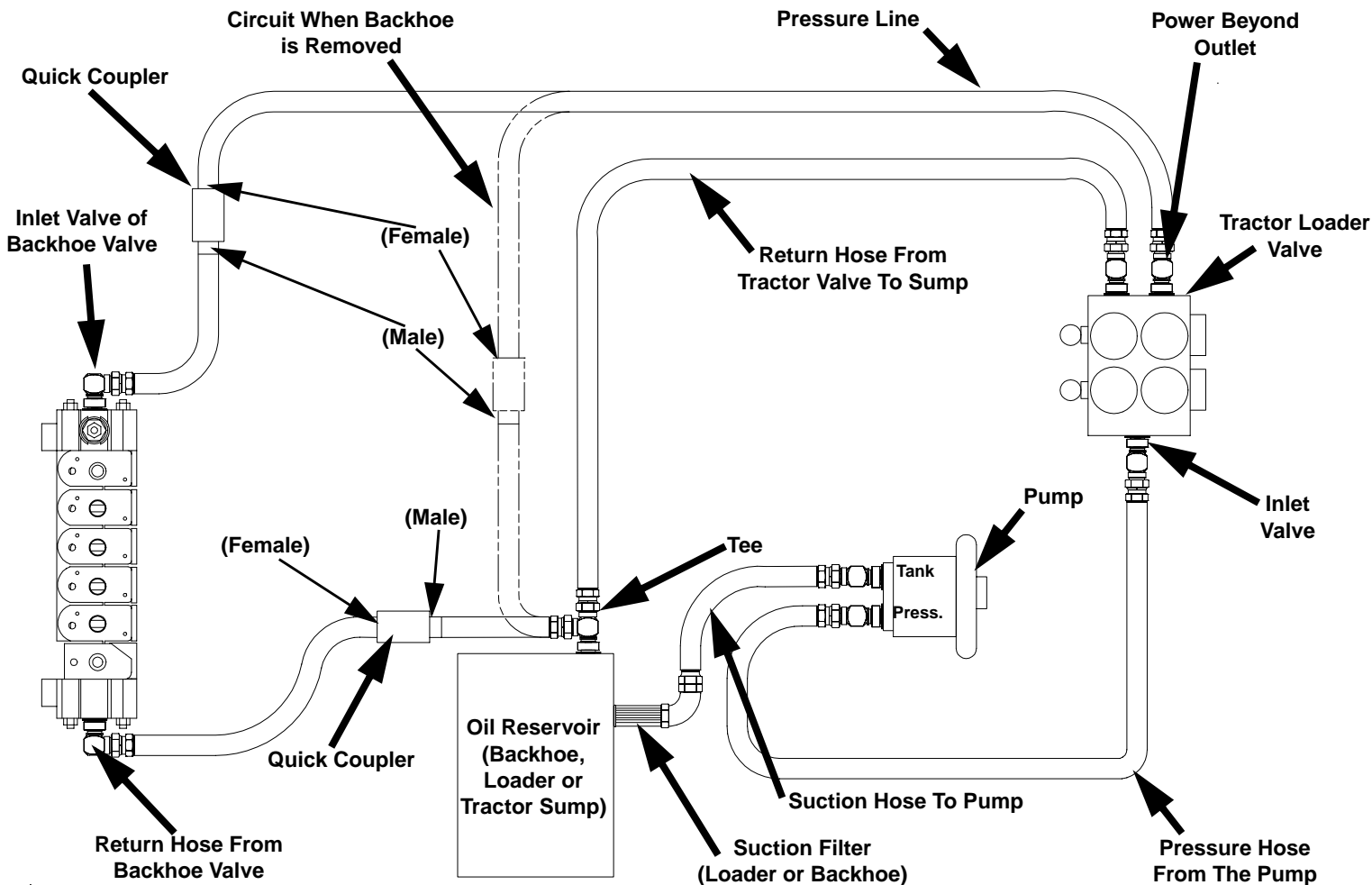

Power Beyond Independent Hydraulic Systems
Figure 1-3

19388

Section 1: Assembly and Set-Up

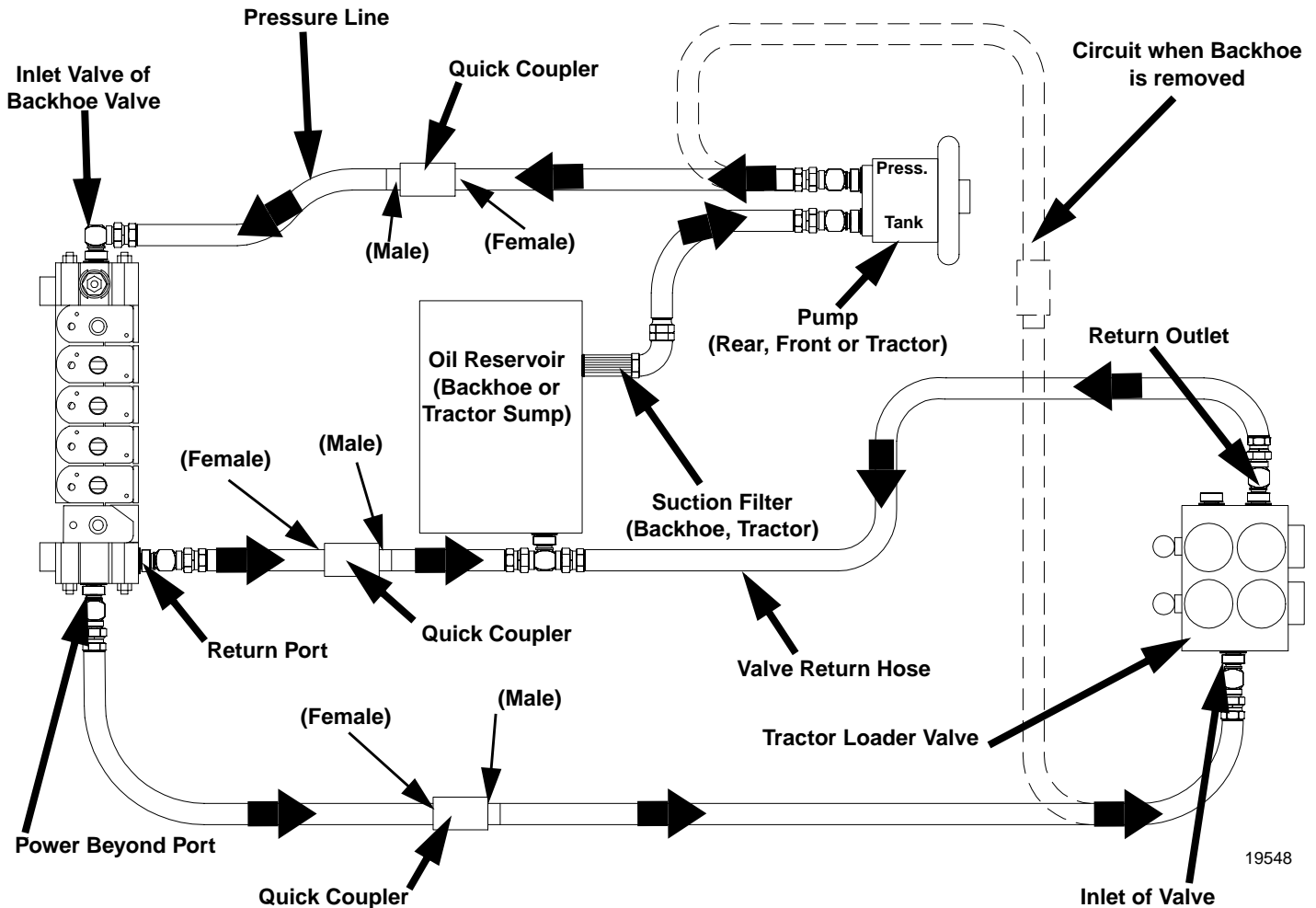

Backhoe Independent Hydraulic Systems

Figure 1-4

Testing Procedure for Hydraulic Circuits

Identification of terminology:

1. PSI (Pounds per square inch)-Represents Power
2. GPM (Gallons per minute)-Represents Speed

A glycerin filled hydraulic pressure gauge (located on the right hand side of the valve) is factory installed on your Land Pride Backhoe for your convenience in testing and diagnosing any problem that may arise in the backhoe hydraulic system.

The gauge indicates only PSI, but with proper use, one can diagnose almost any hydraulic problem in a backhoe's hydraulic system. The first thing to remember is the backhoe hydraulic valve is made of six individual valves, each doing a single function. The only thing that is common to the valve bank is the hydraulic valve and the master relief valve.

Testing Open Center System

Check the pump and master relief: If a problem exists on all hydraulic circuits, the pump or master relief usually causes it. To check these, operate the tractor at a very

low speed while actuating the stabilizer control in the UP position until the cylinder is entirely collapsed, continue holding the control lever and read the PSI on the gauge. Next, speed the tractor up. If the PSI increases as the speed increases, this indicates a worn pump. If the PSI remains steady, but less than 2250 lbs, then the backhoe's master relief is set too low (See HOW TO SET PRESSURE ON MAIN RELIEF VALVE section).

CAUTION!

Never attempt to adjust any relief valve without a gauge in a pressure line.

Checking a Single Circuit

If the power or speed goes down on one function the problem is in that valve section, circuit relief, cylinder, or a restriction in the hoses (The boom and stick are restricted to prevent sudden drop). To check the individual circuit, move the cylinder to the end of its stroke, and continue holding the valve, then take a pressure reading and compare the readings, they should be the same. If they are not the same it could be a faulty circuit relief. Circuit reliefs are on the down stroke of the

Section 1: Assembly and Set-Up

boom, the power crowd side of the dipper stick, and both sides of the swing. If the circuit relief is faulty, it could be caused by dirt. This could be rectified by removing and cleaning the circuit relief. See instructions for Circuit Relief Valve.

Checking the Cylinders

Take a reading at idle speed, with cylinder at end of stroke. Next take another reading at high speed. If the pressure increases with speed, it would indicate a faulty cylinder.

Return Hose:

If the return hose bursts, check to see if the high-pressure line is connected to pressure port of the backhoe, or if the return hose is restricted (usually by an oil coupler).

Testing Closed Center System

On a closed center system the gauge will read the same as the tractor's system pressure rating. (e.i. older Closed Center John Deere's will read 2200 to 2250 PSI)

Checking a Single Circuit

If there is a loss of power on one circuit, it may be checked by actuating the valve. The pressure should drop until the end of cylinder stroke, if the pressure does

not return to the original reading, this would indicate a faulty cylinder or circuit relief. Circuit reliefs are on the down stroke of the boom, the power crowd side of the dipper stick, and both sides of the swing. If the circuit relief is faulty, it could be caused by dirt. This could be rectified by removing and cleaning the circuit relief.

Checking the Pump

If the tractor's PSI is rated at 2250 lbs, and the gauge reads less, the tractor's hydraulic system is faulty or the backhoe's valve is improperly set for closed center operation. See Closed Center Hydraulic System Section.

Checking The Cylinders

Take a pressure reading at idle speed, with cylinder at end of stroke. Next take another pressure reading at high speed. If the pressure increases with speed it would indicate a faulty cylinder.

For other hydraulic problems refer to Troubleshooting Section.

Before calling your dealer, fill in the Hydraulic Testing Chart below. The chart below will enable the service man to diagnose nearly all-hydraulic problems you may be having with your backhoe. Be certain that the cylinder is at the end of the stroke when the readings are taken.

Hydraulic Testing Chart

Cylinder Function*	PSI Idle Speed	PSI Full Speed
Stabilizer - Up R.H.		
Stabilizer - Down R.H.		
Stabilizer - Up L.H.		
Stabilizer - Down R.H.		
Dipper Stick - In		
Dipper Stick - Out		
Swing - Left		
Swing - Right		
Bucket - Open		
Bucket - Closed		
Boom - Up		
Boom - Down		

* Reder to Figure 1-5 on Page 13 for Cylinder Locations.

Section 1: Assembly and Set-Up

Using Tractor Hydraulics All Tractors

If you wish to use the tractor hydraulic system, consult the dealer of your tractor for a safe and proper method of connecting the Land Pride BACKHOE to your tractor.

Using Tractor Hydraulics John Deere

The return hose supplied with your Backhoe will not be long enough. You will have to purchase a 1/2" return hose with a length suitable for the following procedure.

Purchase a Port Filter Cover (JOHN DEERE Part number AT301970) from your dealer if filter cover is not already ported for an auxiliary return line. Install it on your tractor.

NOTE: Many newer John Deere tractors will already be equipped for this return hose porting through filter cover cap back to transmission sump.

Attach the backhoe's pressure hose to the tractor quick coupler. Attach the backhoe's return hose to the port filter cover that you installed. Move the control lever on

the tractor so that it starts a flow to the backhoe valve, and secure it in full open position.

The above procedure results in a direct connection to the JOHN DEERE master pump, and eliminates a return into the rear transfer pump chamber. The problem with returning oil into the rear transfer pump chamber is that if the tractor engine RPM is throttled down to a point at which the oil transfer pump cannot supply sufficient oil to the main system pump, the main pump runs out of oil in its sump and starts chattering.

Mounting The Backhoe

IMPORTANT: Make sure that there is sufficient clearance for the operator if the backhoe is mounted to a tractor with a cab or is equipped with a ROPS. The ROPS may need to be extended or flipped around to obtain sufficient clearance.

Description of Major Backhoe Parts

Refer to Figure 1-5:

1. Familiarize yourself with all of the terms in the following instructions "Description of Major Backhoe Parts".

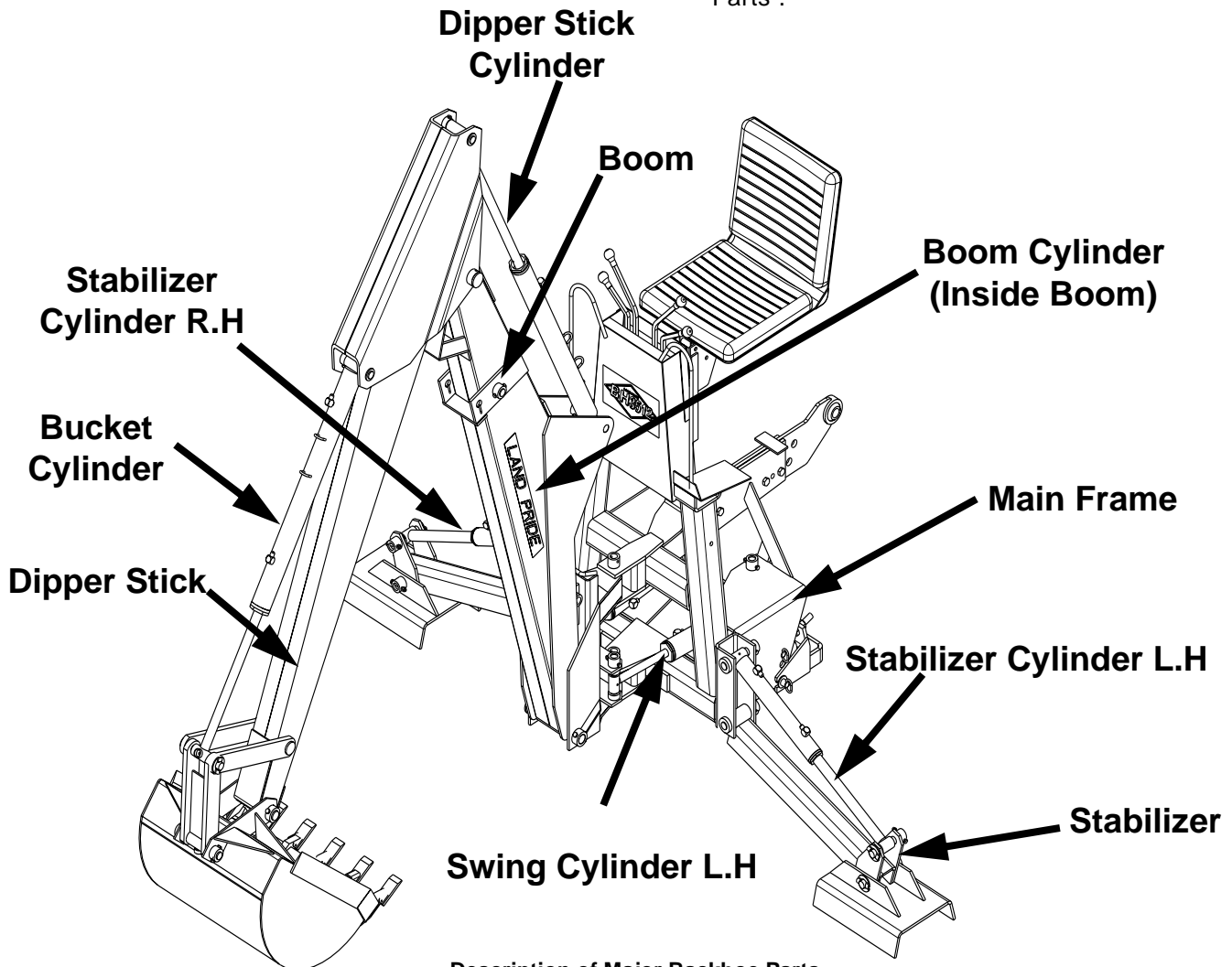

Description of Major Backhoe Parts
Figure 1-5

Section 1: Assembly and Set-Up

2. Back tractor against backhoe in mounting position.
3. Connect tractor's upper 3-point to backhoe.
4. Apply hydraulic power to the backhoe.
5. Raise the boom to take the tension off of the boom lock so you can release the lock. Figure 1-6.

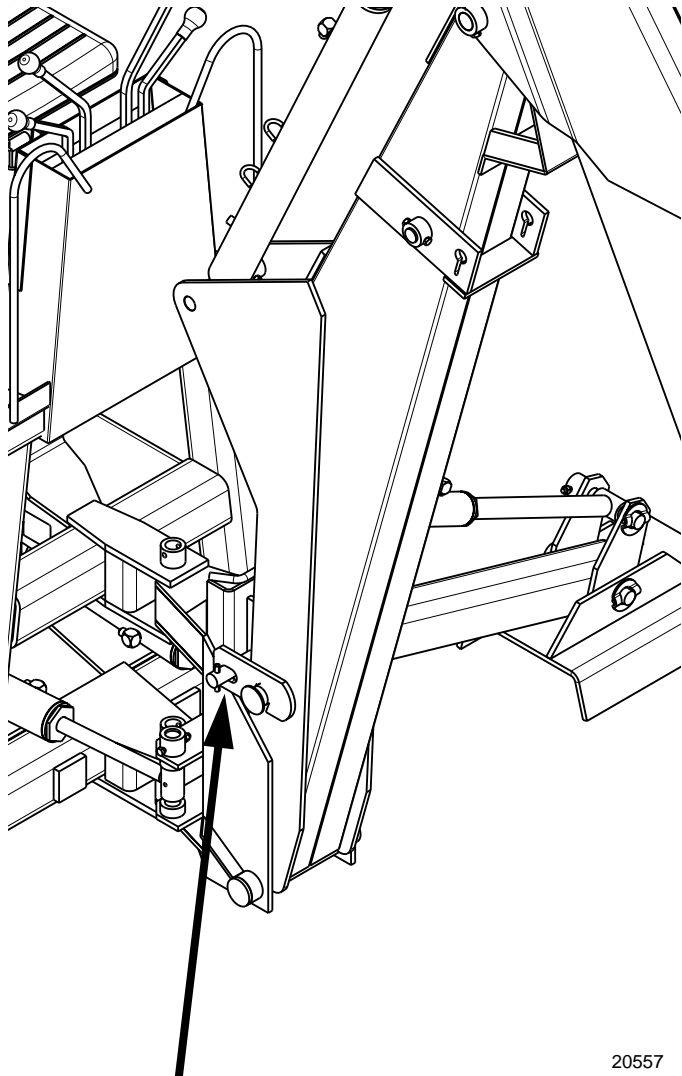

Transport Lock

**Transport Lock
Figure 1-6**

6. Remove the pin (#3) and extend the dipper stick cylinder until the rod end lines up with the holes in the dipper stick, re-install pin (#3), bolt (#1) & lock nut (#2). Refer to Figure 1-7.

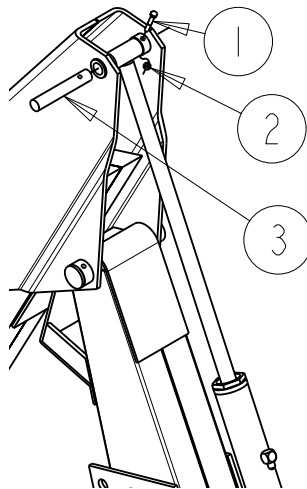

**Dipper Cylinder Installation
Figure 1-7**

20559

CAUTION!

Keep all people clear of your work area during the next steps. Until the backhoe is securely mounted, the operator should make sure that no portion of his body is beneath any part of the backhoe.

7. Extend boom and lower dipper stick until they contact the ground.
8. By manipulating the cylinder and placing down pressure on the boom and stabilizers, lift the backhoe vertically to approximately 10" to 12" of ground clearance.

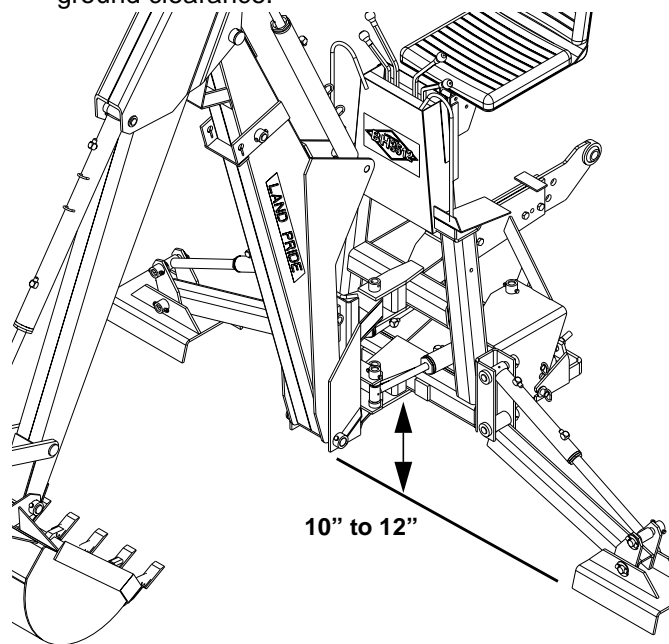

**Ground Clearance
Figure 1-8**

19380

Section 1: Assembly and Set-Up

9. Attach the backhoe to the lower lift arms of the tractor using the pins that are attached to the pallet. Refer to Figure 1-9.
10. Remove the two 7/8" bolts in order to free the top link. Refer to Figure 1-9.
11. Mount the top link to the tractor. There is no correct side up for the top link. There are four different offset positions for the top link's vertical and horizontal adjustment to match backhoe frame depending on your tractor's 3-point.
12. Mount the top link of the backhoe to the main frame of the backhoe. To do this, maneuver the backhoe until you can align two holes in the backhoe frame with a set of holes in the top link. It is important to pick a set of holes that places the backhoe in a vertical position in relationship to the ground with a 10" to 12" ground clearance. There are four possible positions.

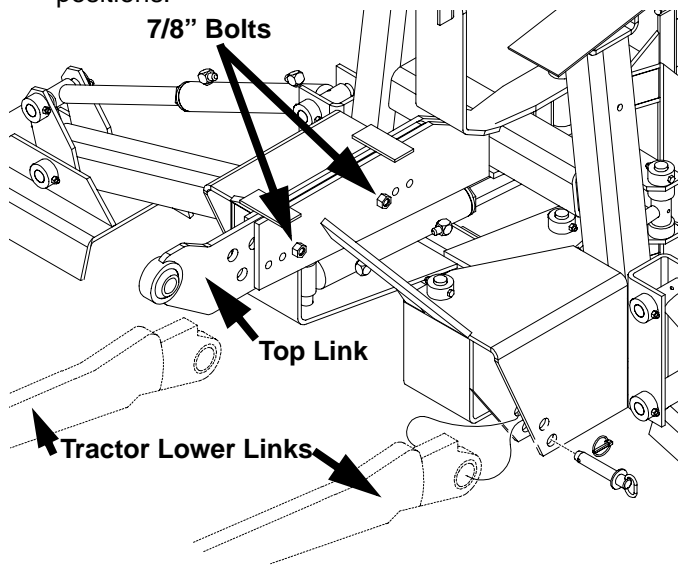

Mounting Top Link
Figure 1-9

13. If you have to make adjustments, make sure that the backhoe tilts towards the tractor rather than away. If you cannot find a satisfactory set of holes, turn the top link upside down and try again. In some cases it may be necessary to drill additional holes in the top link or to shorten the top link.

14. Once an appropriate set of holes is found, secure the backhoe to the top link using the two 7/8" x 2-1/2" bolts and hardware that were removed in Step 20.

WARNING!

Tractor roll bars and tractor cabs can present a danger in the operation of a three point mounted backhoe. We do not recommend the use of a three-point backhoe in conjunction with either a roll bar and/or a tractor cab.

WARNING!

Tractors with cabs must have at least 24" minimum clearance between the end of lower links and tractor cab. Operator must have at least 8" clearance between his back and tractor cab.

WARNING!

Tractor should be equipped with a front end loader or equivalent front-end weight for safe and stable operation.

CAUTION!

No warranty shall be allowed as to the attachment of the backhoe to specific tractors. It is beyond our control that tractor manufacturers make changes which may require minor alterations of the BH3512.

CAUTION!

For tractors with a top link draft control system, make sure the draft control is in its heavy position. It is very important to prevent the top link from exerting pressure that may activate the draft control system. Continued operation with the draft control system activated can cause overheating of the hydraulic fluid and can cause tractor hydraulic pump failure. Put the draft control lever to the bottom of the quadrant.

WARNING!

*You must secure the backhoe top link to the main backhoe frame with TWO 7/8" x 2-1/2" bolts and hardware. **EXTREME DANGER** exists to the operator if the procedure is not properly followed.*

Section 1: Assembly and Set-Up

Bucket Installation

Refer to Figure 1-10:

Assemble the bucket (#1) with the pins (#2) and roll pins (#3) as shown.

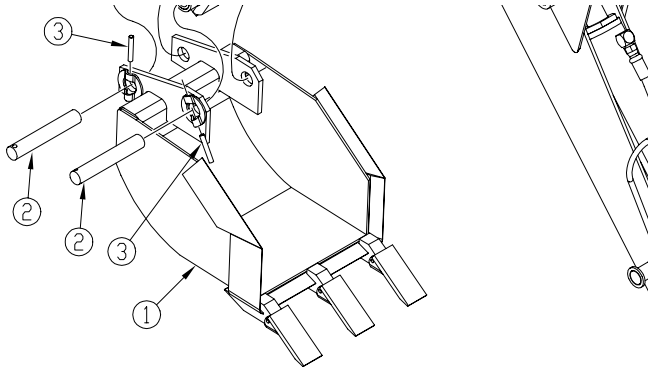

**Bucket Installation
Figure 1-10**

19369

Locking Bar Installation (Optional)

1. After the backhoe is attached to the tractor in working position proceed with the following steps to install the lower drawbar link locks in Figure 1-9.
2. Install pins (#3) through eyebolt (#2) with the eyebolts being located on each side of backhoe lower link sockets. Secure pins in place with lynch pins(#4).
3. Install lower link lock angles right (J) and left (K) as indicated in the drawing. Place lockwashers (L) and install nuts (M) on eyebolts and snug nuts in place.
4. Adjust the 3/4" bolt against the tractor drawbar link. Lock adjustment screw (N) with locknut (O).
5. Tighten eyebolt (#2) with nut and jam nut.

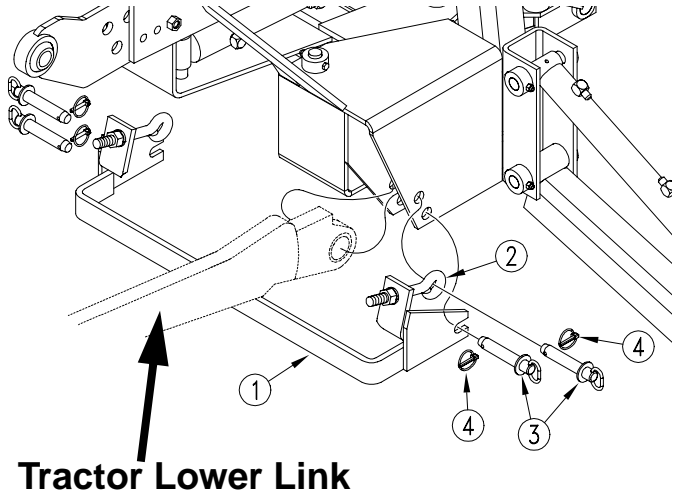

**Locking Bar Installation
Figure 1-9**

Seat Assembly

Refer to Figure 1-11:

Assemble the seat as shown with the 3/8" flange nuts. Adjust seat positioning to your comfort by releasing latch located beneath the front of the seat.

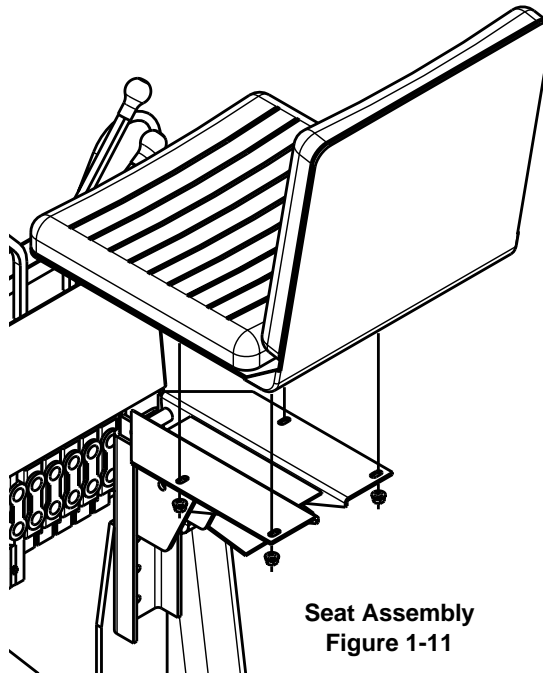

**Seat Assembly
Figure 1-11**

19368

Section 2: Operating Instructions

IMPORTANT: When loading or unloading, dipper stick Must be extended to avoid contact with ground. Failure to do so may result in serious damage to backhoe assembly. Refer to Figure 2-1.

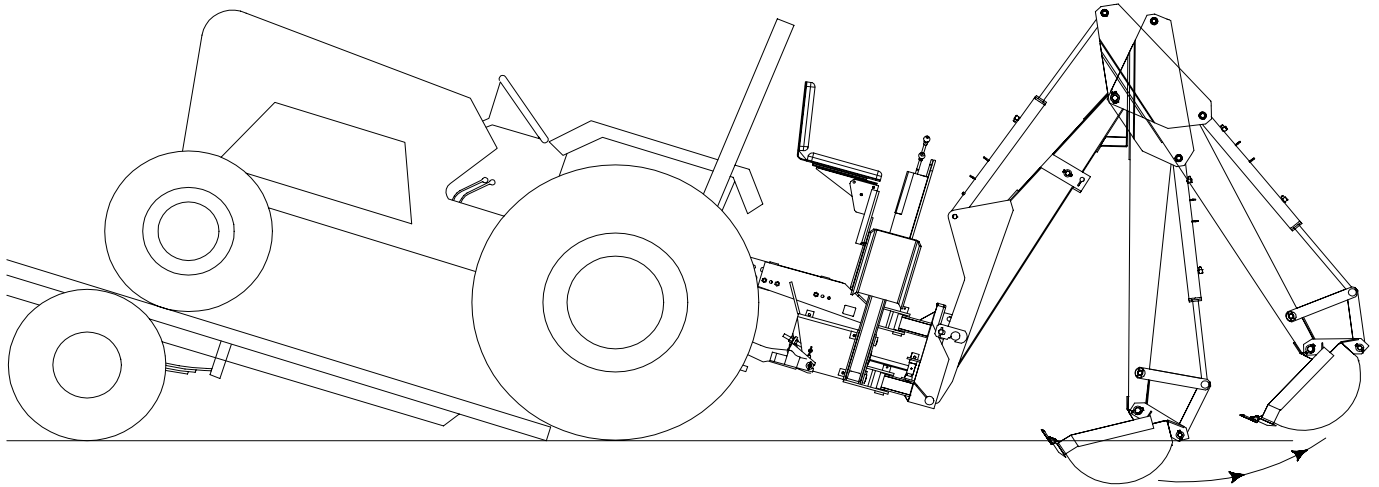

Unloading Backhoe From Trailer
Figure 2-1

19563

Preparing For Operation

Preparing The Backhoe

Unlock the boom lock. You may have to raise the boom in order to relax the tension on the lock.

Preparing The Tractor

Move the tractor's gearshift lever to a neutral position. Set the engine throttle to the correct RPM. For added stability, lower the front-end loader to the ground (if equipped). Move the draft control lever to the bottom-most position (Refer to your Tractor Operator's Manual for Draft Control Terminology). If you are using an independent hydraulic system, engage the PTO.

Operating The Backhoe



CAUTION!

Operate the backhoe only from the backhoe operator's seat. Be sure to place your feet on the footpads during operation. This protects them from injury that could result from moving parts.



CAUTION!

For tractors with a top link draft control system, make sure the draft control is in its heavy position. It is very important to prevent the top link from exerting pressure that may activate the draft control system. Continued operation with the draft control system activated can cause overheating of the hydraulic fluid and can cause tractor hydraulic pump failure. Put the draft control lever to the bottom of the quadrant.

IMPORTANT: If you are not familiar with the operation of the Backhoe, **DO NOT PROCEED** until you have studied the following "Transporting the Backhoe" section.

Transporting The Backhoe



CAUTION!

While traveling with the backhoe, the tractor must have at least 20% of the combined tractor and backhoe weight on its front wheels. Add additional front-end weight, if necessary, to meet this requirement. This is necessary in order to maintain complete control of the tractor during travel.

When loading or unloading from the trailer, you may need to extend the dipper stick out to keep the bucket from dragging. Refer to Figure 2-1.

Your backhoe comes equipped with a transport lock. See Figure 1-6 on page 14. This transport lock should be put into proper position anytime you are transporting your backhoe. To ready your backhoe for transport, perform the following:

Section 2: Operating Instructions

When hauling the backhoe on a trailer lower the dipper stick to the trailer if possible. See Figure 2-2.

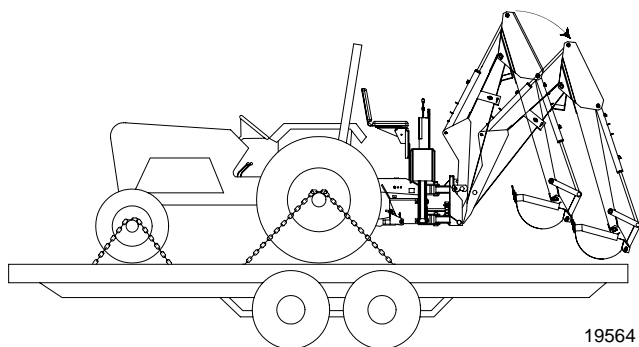

Transporting on Trailer
Figure 2-2

Observe the following precautions while transporting the backhoe with tractor:

1. When traveling on roads, use the proper safety lights and warning signs. (Check your local regulations.)
2. When traveling over rough ground, do not exceed safe speed limits.
3. Do not make sudden starts or stops.
4. When climbing grades, be particularly careful not to make sudden starts.

Control Functions

Refer to Figure 2-3:

In front of you there are four control levers. Right and Left are determined from a seated position in the operator's seat.

Refer to "Description of Major Backhoe Parts" Figure 1-5 on page 13 for the following controls.

Stabilizers

To the outside of the operator's console are the controls for the stabilizers. The left lever controls the left stabilizer, and the right lever controls the right stabilizer. To raise the stabilizers, pull the levers towards yourself. To lower the stabilizers, push the levers forward (away from yourself).

Boom

The center lever on the left side of console controls the boom up and down. Pulling the lever towards you raises the boom; pushing the lever forward lowers the boom. Pushing the lever further into detent float position renders the valve functions inoperable.

Moving this lever to the left swings the boom to the left; moving the lever to the right swings the boom to the right.

Dipper Stick And Bucket

The centered lever on the right side of console controls the dipper stick in and out and the bucket curl and uncurl. Pulling lever towards yourself moves the dipper stick in; pushing the lever forward moves the dipper stick out.

Moving this lever to the left curls the bucket; moving the lever to the right uncurls the bucket.

Familiarize yourself with these controls before beginning to operate the backhoe. After a little experience, you will be able to operate the unit with a smooth, steady motion.

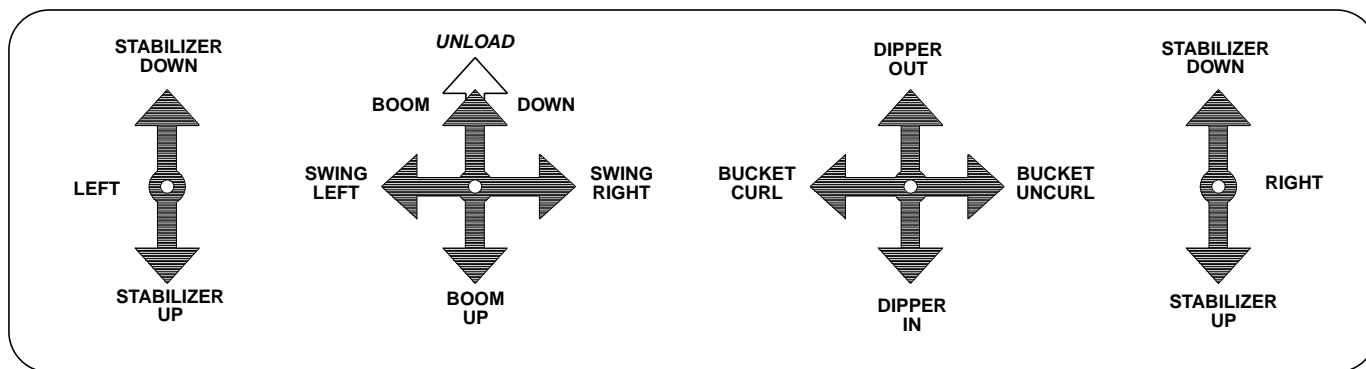

Control Levers
Figure 2-3

Section 2: Operating Instructions

Digging Suggestions



CAUTION!

Always be sure that the stabilizers maintain contact with the ground during digging operations. Take the time to readjust the stabilizers when necessary during digging. Before you begin digging, extend the stabilizers so that they make a firm contact with the ground. This is essential in order to gain the necessary stability and weight transfer to insure safe digging.

Observe the following cautions while digging.



CAUTION!

Before swinging the backhoe, make sure you have room to swing and that all people are clear of the backhoe. For added protection, place a barricade around the swing area before commencing operation.



CAUTION!

Be sure that you are not digging over any underground wiring, pipes, or other obstructions. If there is any doubt, call your public service agency.



CAUTION!

When digging to either side and/or close to the tractor, be extremely careful that the bucket does not contact the stabilizers, as serious damage may occur.



CAUTION!

Be extra careful when working on hillsides and/or close to ditches. It is always extremely dangerous to work in a position where the danger of tipping or sliding exists.



CAUTION!

Digging on a slope should be done from the top down. When digging across a slope, use the stabilizers to keep the backhoe level and ALWAYS dump uphill. Use caution when digging under these conditions. Move the unit carefully and at a safe ground speed.

The following suggestions should aid you in gaining maximum efficiency with your backhoe.

Digging at the Correct Angle

Dipper Stick & Boom

To obtain the best penetration, the dipper stick should be at an angle. Do not extend the boom and the dipper stick out into a straight line. See Figure 2-4.

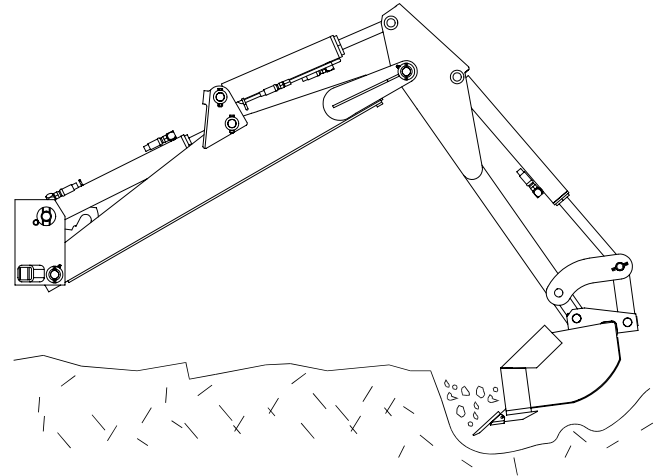

Correct Angle

19374

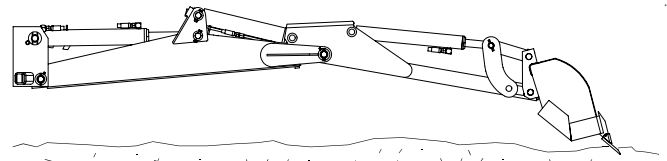

Incorrect Angle

19375

Dipper Stick & Boom Digging Angle
Figure 2-4

Section 2: Operating Instructions

Bucket

After you have filled the bucket, do not pull the dipper stick any closer to the boom than is necessary in order to clear the hole. When the bucket is clear, swing it to the side to dump. Always start dumping far enough to the

side so as not to run out of dumping room. It is desirable while swinging to the side to make contact with the already removed material in order to lessen shock on the machine. This also aids the operator in pushing the material away from the working area.

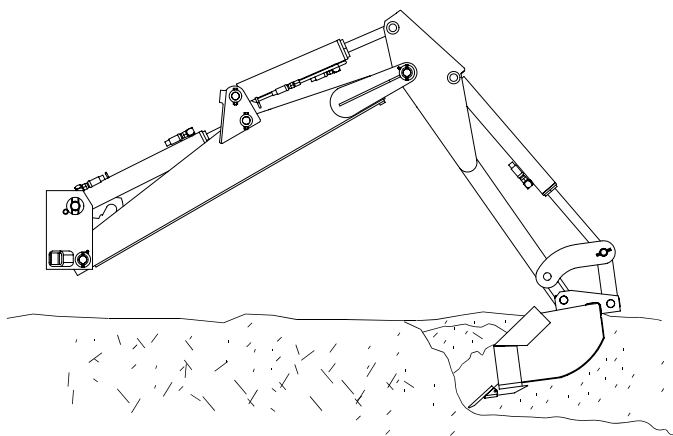

Correct Angle

19376

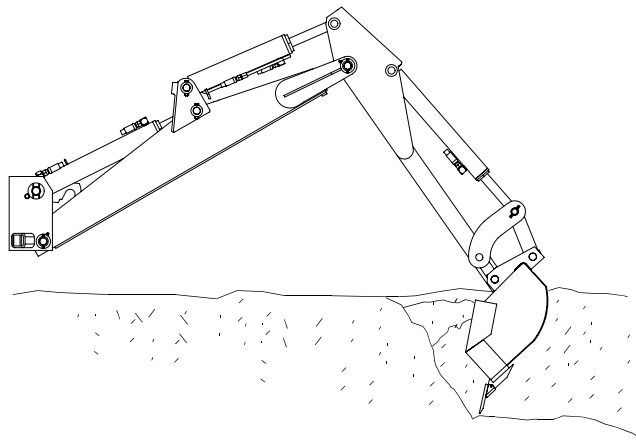

Incorrect Angle

19377

**Bucket Digging Angle
Figure 2-5**

The length of the pass should be just long enough so that the bucket will be full at the end of the pass. The depth of the pass will depend upon the type of soil. Do not drag a full bucket of dirt. After making a pass you will be able to determine how deep you will be able to dig. To control the depth of the pass, work the bucket and dipper stick controls alternately. In this way you can take an even bite each time you make a pass and obtain a full bucket. Refer to Figure 2-6.

When loading trucks, curling the bucket close to the dipper stick will prevent undue spillage when the bucket is raised so that it can be dumped in the truck bed.

To obtain a level bottom, set the bucket teeth at a slight angle. Keep this angle as you drag the bucket with the dipper stick by gradually uncurling the bucket. Intermittently pull the boom lever at the same time to maintain a level bottom.

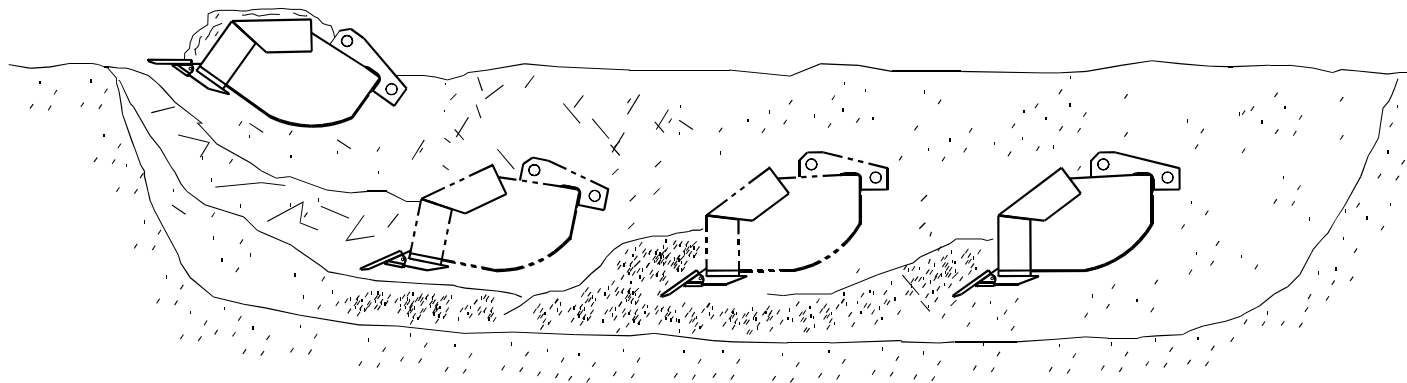

**Level Bottom
Figure 2-6**

19371

Section 3: Maintenance and Lubrication

Maintenance

Proper servicing and adjustment can increase the life of any implement. With careful and systematic inspection, you can avoid costly maintenance, time and repair.



CAUTION!

For safety reasons, each maintenance operation must be performed with the backhoe lowered completely to the ground or folded with the transport boom lock engaged and the tractor engine shut off with ignition key removed.

- After using the backhoe for several hours, check all bolts to be sure they are tight.
- Lubricate items as listed under *Lubrication*, this section, starting on page 22.
- Replace any worn, damaged or illegible safety labels by obtaining new labels from your Land Pride Dealer. Information about labels is located under *Safety Labels* in the “**Important Safety Information**” section starting on page 1.

Storage

For short periods coat all exposed cylinder shafts with grease or a corrosion preventive.

Install dust caps on the quick couplers, if equipped, to prevent dirt contamination of the hydraulic system. Or, if possible, connect the quick couplers together.

At the end of the working season or when the backhoe will not be used for a long period, it is good practice to clean off any dirt or grease that may have accumulated on the backhoe and any of the moving parts. It may be necessary to scrape off compacted dirt from the bucket, then use a garden hose to thoroughly clean the surface.

Inspect the backhoe for loose, damaged or worn parts and adjust or replace if needed.

Lubricate as noted in the *Lubrication* portion of this section starting on page 22.

Repaint parts where paint is worn or scratched to prevent rust. Aerosol touch-up paint is available from your Land Pride dealer. Order Land Pride part # 821-002C for Black.

Store backhoe in a clean, dry place.

Bucket Tooth Replacement

To remove a tooth:

1. Heat the tooth with a torch at point “A” (this is the compressed area that overlaps “B”).
2. Hammer at the top of the tooth until the tooth comes free from the shank.

To replace a tooth:

1. Hammer the tooth onto the shank.
2. Heat at point “A” and hammer the heated section into recess “B”.

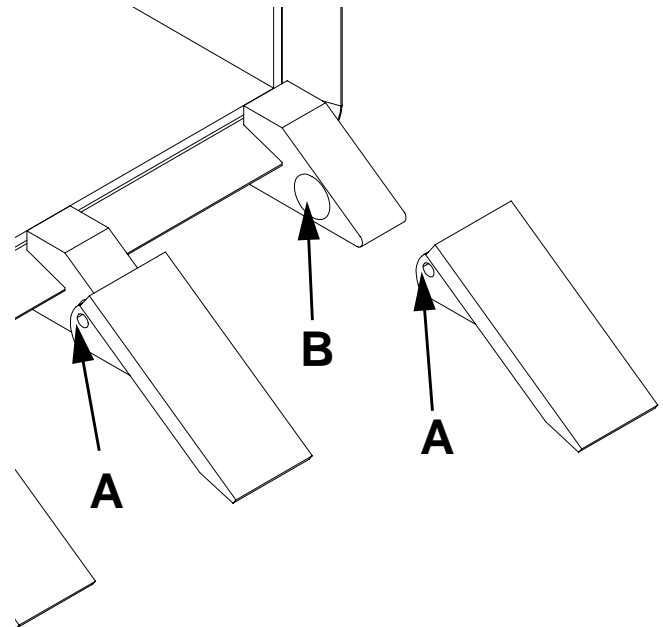





Bucket Tooth Replacement
Figure 5-1

19382



Section 3: Maintenance and Lubrication

Lubrication

Lubrication Legend

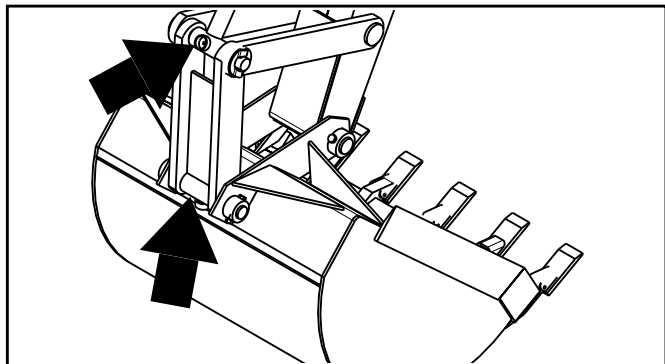
 Multipurpose spray lube	 Multipurpose grease lube	 Multipurpose oil lube	 50	Intervals at which lubrication is required
---	--	---	--	--





	 25
---	--

Bucket Pivot

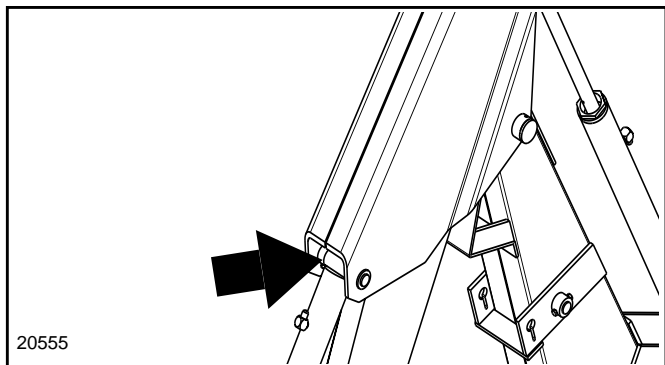
Type of Lubrication: Multipurpose Grease
Quantity = As required





	 25
--	---

Bucket Cylinder Base End

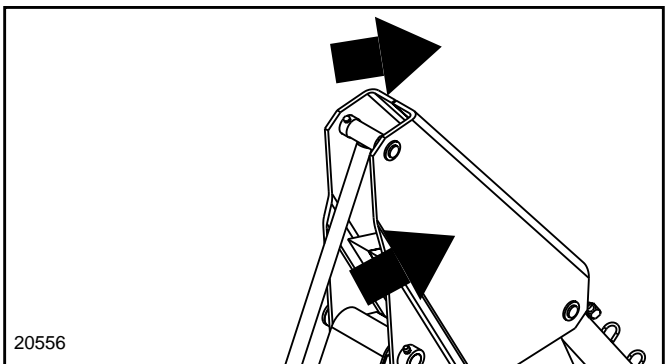
Type of Lubrication: Multipurpose Grease
Quantity = As required



	 25
---	--

Dipper Stick Pivots

Type of Lubrication: Multipurpose Grease
Quantity = As required

Section 3: Maintenance and Lubrication

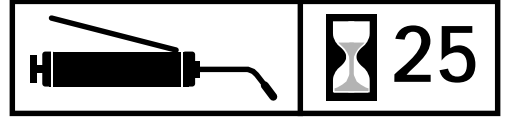
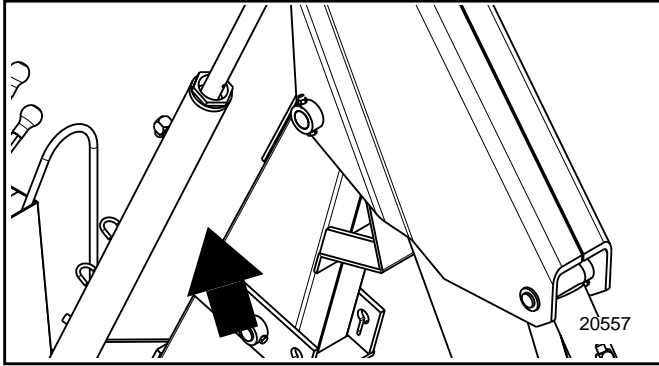

Boom Cylinder Rod End

Type of Lubrication: Multipurpose Grease
Quantity = As required

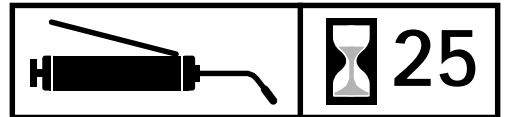
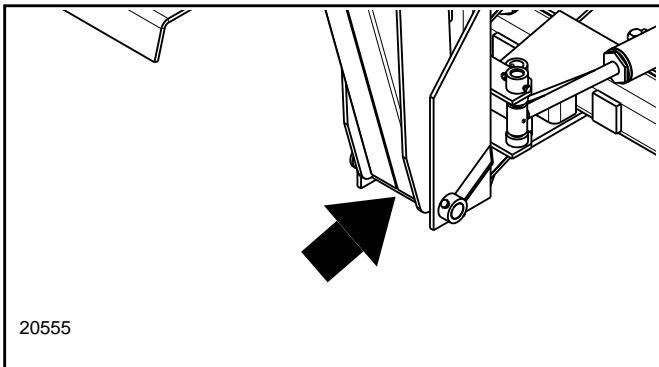

Boom Pivot

Type of Lubrication: Multipurpose Grease
Quantity = As required

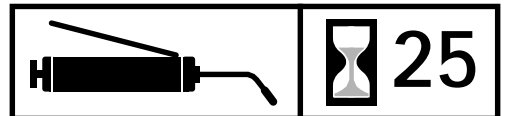
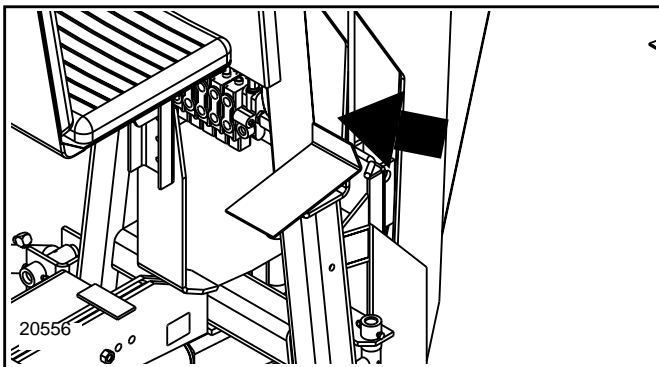

Boom Cylinder Base End

Type of Lubrication: Multipurpose Grease
Quantity = As required

Section 3: Maintenance and Lubrication

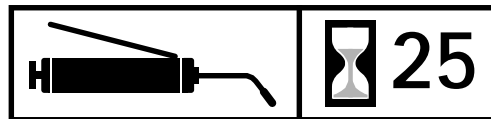
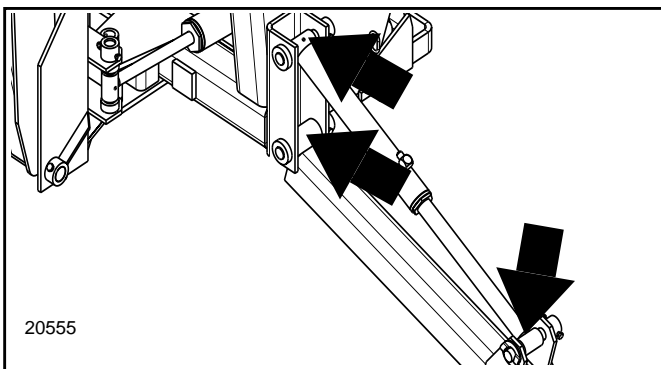

Stabilizer Arms

Type of Lubrication: Multipurpose Grease

Quantity = As required

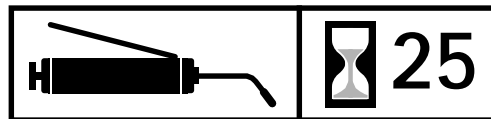
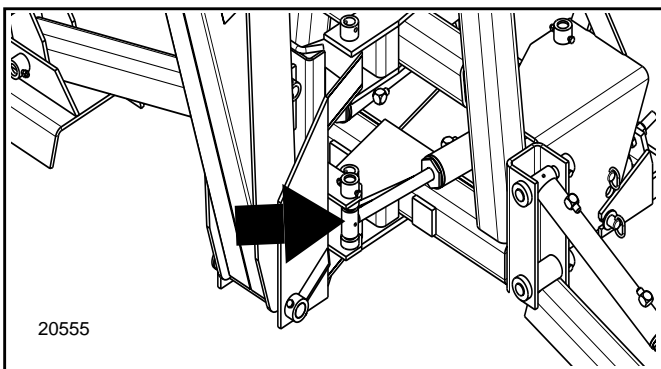

Boom Swing Cylinder Rod End

Type of Lubrication: Multipurpose Grease

Quantity = As required

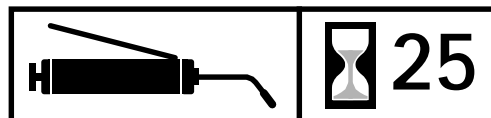
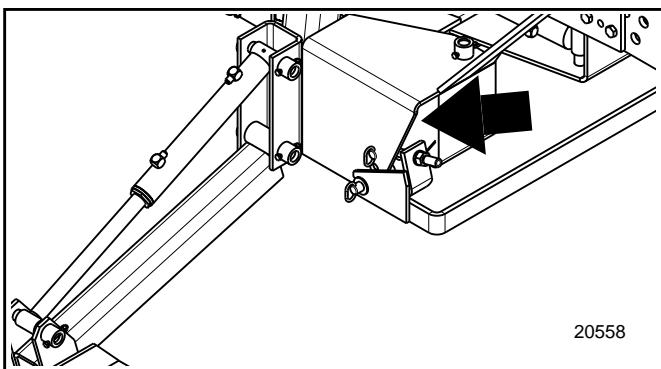

Boom Swing Cylinder Base End

Type of Lubrication: Multipurpose Grease

Quantity = As required

Section 4: Specifications & Capacities

BH35 Series Backhoes	
	BH3512
Tractor Horse Power Rating	50 -150
Maximum Digging Depth	12' 6"
Digging Depth 2" Flat Bottom	12'
Reach from Swing Pivot	14' 6"
Transport Height	9' 3"
Bucket Clearance or Loading Height	9' 2"
Bucket Curl	172 deg.
Swing Arc	180 deg.
Stabilizer Spread-Folded Down, Operating Position	10' 7"
Stabilizer Spread-Folded Down, Transport Position	6' 5"
Hydraulic System	Four Lever 6-spool control valve
Main Circuit Relief	2250 PSI four individual circuit reliefs
Hydraulic Fluid Minimum	8.0 GPM
Hydraulic Fluid Maximum	11.0 GPM
Boom Lifting Power (boom straight out, dipper stick at 90 deg.)	1729 lbs. (less bucket)
Boom Lifting Power (boom and dipper stick extended.)	900 lbs.
Bucket Cylinder Digging Force	5,500 lbs.
Dipper Stick Cylinder Digging Force	3,300 lbs.
Bucket Pryout Power (partially curled)	12,500 lbs.
Tractor 3-Point Hitch	Cat. 2 & 3
Hydraulic Cylinders	Equipped with NitroSteel corrosive resistant black shafting
Swing Cylinders	Dual
Swing Shock Absorbers	Hydraulic swing cushion protection
Pins	Locked in place, grease zerks at pivot points
Transport Lock	Safety transport boom flip-over lock
Bushings	Replaceable, steel, at all major pivot points
Hydraulic Pressure Gauge	Standard
Adjustable Hinged Seat	Standard
Ripper Tooth	Optional
Locking Bar Mount	Optional
Independent Hydraulic System	Optional

BH35 Series Backhoes

Features	Benefits
Tractor HP range	50-150 HP
Hitch – 3-Point	Rigid Hitch Mount with Stabilizing Kit for Maximum digging stability.
Tubular Construction	Tubular and box designed frame, on boom and dipper stick assemblies for added strength and longer life.
Relief Valve Protection	One master and four circuit relief valves with anti-cavitation feature to protect against accidental overloads and errors in operation.
Wide Stance Stabilizer Legs	Wide support base with large steel foot pads for more stable and safer operational control.
Optional Rubber Street Pads	Rubber pads can be added to steel stabilizer pads when using on concrete to keep from sliding.
Plated and Locked Wear Pins	Plated and locked pins on all pivot points for added safety.
Pivot Point Replaceable Bushings	All pivot points have replaceable and greaseable plated wear bushings for longer life.
Double Acting Cylinders	With Nitro-Steel black piston rods for superior wear and corrosive resistance over chrome shafts. High quality internal seals for dependable long life performance.
Six spool valve	Two lever hydraulic valve with excellent feathering characteristics and minimum cylinder cavitation for easy operation and control.
Safety Boom Lock	Standard on all models for transportation safety.
Hydraulic Swing Cushion Protection	Patented swing cushion slows down and stops swing automatically, prevents 'shock loads' at the end of arm travel.
Two Double Acting Swing Cylinders	One cylinder pushing and one pulling for a powerful, smooth and controllable swing arch.
Lower Drawbar Link Locks	Standard on all models for more stability in operation and less stress in transportation.
Hydraulic Hose Protection	Abrasive-resistant coverings for longer life.
Adjustable Folding Seat	Offering more comfort and room for operation and less operator fatigue.
Hydraulic Pressure Gauge Kit	Standard equipment and positioned on control valve for easy observation.
Independent Hydraulic System	Optional with 540 gear type pump
Bucket Options	12" to 36" Bucket options
Power Beyond Option	Control valve adaptability - available as an optional kit.
Digging Depth Maximum Range	12' - 6"
Maximum Reach from Swing Point	14' - 6"
Swing Arch	180 degrees
Bucket Rotation	172 degrees
Bucket Pry Out Power	12,500 lbs.

Section 6: Troubleshooting

Problem	Cause	Solution
Sticking plungers in Hydraulic Valve	Excessively high oil temperature.	Eliminate restrictions in pipe lines and filtering system.
	Dirt in oil.	Change oil-clean system.
	Pipe fittings too tight.	Check torque.
	Valve warped from mounting.	Loosen valve and check.
	Excessively high pressure in valve	Check with gauge on inlet and cylinder lines.
	Handle or linkage binding.	Free up linkage.
	Plunger bent.	Replace valve or section.
	Return spring damaged.	Replace faulty parts.
	Spring or detent cap binding.	Loosen cap, re-center and re-tighten.
	Valve not at thermal equilibrium.	Let system warm up.
Leaking Seals in Hydraulic Valve	Paint on or under seal.	Remove and clean.
	Excessive back pressure.	Open or enlarge line to reservoir.
	Dirt under seal.	Remove and clean.
	Scored plunger.	Replace valve or section.
	Loose seal plates.	Clean and tighten.
	Cut or scored seal.	Replace faulty parts.
Unable to move plunger in Hydraulic Valve	Dirt in valve.	Clean and flush out.
	Plunger cap full of oil.	Replace seals.
	Bind in linkage.	Free up linkage.
Blown or leaking O-ring seals between valve sections in Hydraulic Valve	Improperly connected.	Replace O-Ring seals. Make sure all connections are as shown in the assembly section of this manual.
	Return line was replaced with high pressure hose.	Replace O-Ring seals. Remove high pressure hose and replace it with correct low pressure hose.
	Valve used in power beyond application without installation of power beyond sleeve.	Replace O-Ring seals. Install power beyond sleeve as shown in assembly section of this manual.
Can't get pressure in Relief Valve	Poppet stuck open or dirt under seat.	Check for foreign matter between poppets and their mating members. Members must slide freely.
Erratic pressure in Relief Valve	Pilot poppet seat damaged. Poppet sticking in relief valve housing.	Remove and clean dirt out. If parts are damaged, replace complete relief valve.
Pressure setting not correct in Relief Valve	Wear due to dirt. Locknut and adjustment screw loose.	See "How to Set Pressure". Check seats for scratches, nicks or other marks. Replace valve if damaged.
Relief Valve leaks	Damaged seats, worn O-Rings, parts sticking due to dirt.	Replace worn or damaged O-Rings and back up rings. Inspect for free movement of components, check seat for scratches, nicks or other marks. Replace complete relief if metal parts are damaged.
Backhoe does not operate	Low oil supply.	Add oil.
	Hoses not properly connected.	Check hose connections.
	Worn or damaged pump.	Replace or repair pump.
	Broken line.	Check for leaks. Replace line.

Section 6: Troubleshooting

Problem	Cause	Solution
Slow operation and poor Hydraulic System performance	Engine speed too low.	Adjust RPM's.
	Defective pump.	Check pressure or replace.
	Load too heavy.	Check line pressure.
	Faulty main relief valve.	Clean or replace main relief valve.
	Internal valve crack.	Replace valve section.
	Suction line filter plugged.	Clean.
	Oil too heavy for cold weather use.	Replace with lighter oil.
	Power supply may not be plumbing enough oil.	Use a flow meter to check out whether 4-8 GPM flow rate is being achieved.
	Low oil level.	Add oil.
	Pressure line restricted.	Check for obstruction.
	Collapsed suction line.	Check for damage.
	Valve spool not at full stroke.	Check movement and linkage.
Backhoe does not hold up load	Cylinder seals leaking.	Replace seals.
	Valve spool leaking.	Replace seals.
	Oil bypassing valve spool.	Replace valve bank.
Load drops when valve spool moved from neutral	Dirt in load check valve.	Disassemble and clean.
Excess oil heat	Damaged or worn pump.	Repair or replace.
	Too fast of an engine speed.	Reduce throttle.
	Main relief bypass valve improperly set.	Check relief setting.
	Draft control lever not all the way down.	Position correctly.
Oil leakage	Valve spool seals.	Replace seals.
	Loose hose fittings.	Tighten just enough to stop leakage.
	Broken oil line.	Replace hose or line.
Independent Hydraulic system pump failure	Improperly set relief valve.	Set relief at 1400 PSI.
Independent Hydraulic system pump Noisy	Suction line filter plugged.	Clean filter.
	Oil too heavy.	Use a lighter oil.
Jerky or erratic action	Air in system.	Check for loose connections and/or cycle all valves to remove air.
	Wrong type of oil.	Check tractor manual. For Independent Hydraulic System use Type A non-foaming hydraulic oil.
	Foamy oil.	Check tractor manual. For Independent Hydraulic System, use a Type A non-foaming hydraulic oil.
Blown Return Valve	Improperly connected.	Make sure all connections are as shown in the assembly section of this manual.

Section 7: Appendix

Torque Values Chart													
in-tpi ¹	Bolt Head Identification						mm x pitch	Bolt Head Identification					
	Grade 2		Grade 5		Grade 8			Class 5.8		Class 8.8		Class 10.9	
	N · m	ft-lb ³	N · m	ft-lb	N · m	ft-lb	N · m	ft-lb	N · m	ft-lb	N · m	ft-lb	
1/4" - 20	7.4	5.6	11	8	16	12	M 5 X 0.8	4	3	6	5	9	7
1/4" - 28	8.5	6	13	10	18	14	M 6 X 1	7	5	11	8	15	11
5/16" - 18	15	11	24	17	33	25	M 8 X 1.25	17	12	26	19	36	27
5/16" - 24	17	13	26	19	37	27	M 8 X 1	18	13	28	21	39	29
3/8" - 16	27	20	42	31	59	44	M10 X 1.5	33	24	52	39	72	53
3/8" - 24	31	22	47	35	67	49	M10 X 0.75	39	29	61	45	85	62
7/16" - 14	43	32	67	49	95	70	M12 X 1.75	58	42	91	67	125	93
7/16" - 20	49	36	75	55	105	78	M12 X 1.5	60	44	95	70	130	97
1/2" - 13	66	49	105	76	145	105	M12 X 1	90	66	105	77	145	105
1/2" - 20	75	55	115	85	165	120	M14 X 2	92	68	145	105	200	150
9/16" - 12	95	70	150	110	210	155	M14 X 1.5	99	73	155	115	215	160
9/16" - 18	105	79	165	120	235	170	M16 X 2	145	105	225	165	315	230
5/8" - 11	130	97	205	150	285	210	M16 X 1.5	155	115	240	180	335	245
5/8" - 18	150	110	230	170	325	240	M18 X 2.5	195	145	310	230	405	300
3/4" - 10	235	170	360	265	510	375	M18 X 1.5	220	165	350	260	485	355
3/4" - 16	260	190	405	295	570	420	M20 X 2.5	280	205	440	325	610	450
7/8" - 9	225	165	585	430	820	605	M20 X 1.5	310	230	650	480	900	665
7/8" - 14	250	185	640	475	905	670	M24 X 3	480	355	760	560	1050	780
1" - 8	340	250	875	645	1230	910	M24 X 2	525	390	830	610	1150	845
1" - 12	370	275	955	705	1350	995	M30 X 3.5	960	705	1510	1120	2100	1550
1-1/8" - 7	480	355	1080	795	1750	1290	M30 X 2	1060	785	1680	1240	2320	1710
1 1/8" - 12	540	395	1210	890	1960	1440	M36 X 3.5	1730	1270	2650	1950	3660	2700
1 1/4" - 7	680	500	1520	1120	2460	1820	M36 X 2	1880	1380	2960	2190	4100	3220
1 1/4" - 12	750	555	1680	1240	2730	2010							
1 3/8" - 6	890	655	1990	1470	3230	2380							
1 3/8" - 12	1010	745	2270	1670	3680	2710							
1 1/2" - 6	1180	870	2640	1950	4290	3160							
1 1/2" - 12	1330	980	2970	2190	4820	3560							

¹ in-tpi = nominal thread diameter in inches-threads per in.
² N · m = newton-meters
³ ft-lb= foot pounds
⁴ mm x pitch = nominal thread diameter in millimeters x thread pitch

Torque tolerance + 0%, -15% of torquing values. Unless otherwise specified use torque values listed above.

Section 7: Appendix

Notes

Section 7: Appendix

Warranty

Land Pride warrants to the original purchaser that this Land Pride product will be free from defects in material and workmanship beginning on the date of purchase by the end user according to the following schedule when used as intended and under normal service and conditions for personal use.

Overall Unit: One year Parts and Labor

Hydraulic Cylinder: One year Parts and Labor.

Hoses and Seals: Considered wear items.

This Warranty is limited to the replacement of any defective part by Land Pride and the installation by the dealer of any such replacement part, and does not cover common wear items such as blades, belts, tines, etc. Land Pride reserves the right to inspect any equipment or parts which are claimed to have been defective in material or workmanship.

This Warranty does not apply to any part or product which in Land Pride's judgment shall have been misused or damaged by accident or lack of normal maintenance or care, or which has been repaired or altered in a way which adversely affects its performance or reliability, or which has been used for a purpose for which the product is not designed. Misuse also specifically includes failure to properly maintain oil levels, grease points, and driveline shafts.

Claims under this Warranty must be made to the dealer which originally sold the product and all warranty adjustments must be made through such dealer. Land Pride reserves the right to make changes in materials or design of the product at any time without notice.

This Warranty shall not be interpreted to render Land Pride liable for damages of any kind, direct, consequential, or contingent to property. Furthermore, Land Pride shall not be liable for damages resulting from any cause beyond its reasonable control. This Warranty does not extend to loss of crops, any expense or loss for labor, supplies, rental machinery or for any other reason.

No other warranty of any kind whatsoever, express or implied, is made with respect to this sale; and all implied warranties of merchantability and fitness for a particular purpose which exceed the obligations set forth in this written warranty are hereby disclaimed and excluded from this sale.

This Warranty is not valid unless registered with Land Pride within 30 days from the date of purchase by the end user.



Corporate Office: PO. Box 5060
Salina, Kansas 67402-5060 USA
www.landpride.com
