



73 SAE NET HORSEPOWER

J

LOADER

304J



Agile, productive, powerful, and ready for anything.



Need a compact loader to get big results? Choose the 304J. This versatile 73-hp machine combines outstanding maneuverability, travel speed, breakout force, reach, and stability in an innovative package. Its oscillating stereo steering delivers a turning radius that's 20-percent tighter than comparable loaders for fast work cycles.

Delivers smooth moves and better material retention over rough terrain, too. Add to that a redesigned, more spacious cab, and extra uptime from sealed electrical connections, more durable axles, and extended service intervals, and you've got a multi-purpose machine that's ready, able, and willing to take on your many tasks.



304J Loader key specifications

Operating Weight.....	13,404 lb.
Net Horsepower.....	73 hp
Full Turn Tip Load.....	9,315 lb.
Bucket Size.....	1.4 cu. yd.
Bucket Breakout Force.....	12,364 lb.

Unique stereo steering makes this compact loader even more productive, for tight turns and extra agility in close quarters.

Comes with standard items others call options — return to dig, quick-coupler, high travel-speed range, and 1.4-cubic-yard bucket.

Extended service intervals help maximize uptime.

100-percent manual differential lock helps you dig down deep for more power.

Tier 3 emissions-certified five-cylinder turbocharged John Deere diesel delivers power without compromise.

Unlike comparable-size machines, return-to-dig is standard on the 304J.

Oscillating stereo steering combines machine articulation and rear-axle steering, giving the 304J the tightest turn radius in its class.

Twenty-inch tires are standard.



1



2



3



4



5

1. Boom float allows easy backdragging for finish grading and cleaning up jobsites.
2. The 304J's unique design turns tight but articulates less, keeping the center of gravity and ballast in line to counteract load forces — for superior full-turn tipping load capacity.
3. An oscillating rear axle and elastic articulation at the pivot smoothes the ride for greater material retention and reduced operator fatigue.
4. 304J's long reach lets it easily dump to the center of tandem-axle trucks for quicker and easier loading.
5. Manual low-speed differential lock delivers the traction needed to go deeper into the pile for bigger bucket loads.





Give crowded conditions the runaround.

When the going gets rough, get your hands on a 304J and get going. Unlike other machines that are frequently forced into three-point turns (or worse), this nimble loader's stereo steering allows a tight 148-inch turn radius for unsurpassed maneuverability. Delivers higher tipping load capacities, too. What's more, the

hydrostatic drivetrain's infinitely variable range lets you precisely match travel speed to the work at hand. So you can inch ahead while maintaining full hydraulic power. Or max out at a fastest-in-class 19 mph. The 304J lets you move more materials, more quickly, and more efficiently. Without running you ragged.



Efficient interior provides plenty of room for productivity.

When operation is easy, maximum productivity becomes second nature. The 304J's sound-suppressed spacious cab provides ample leg- and headroom, best-in-class all-around visibility, and one smooth ride. A single lever with FNR switch controls all boom and bucket functions, and standard

return-to-dig is just a flick-of-the-wrist away. Gauges in the forward console are clearly visible, intuitive, and easy to read. Tilt steering, multi-adjustable high-back suspension seat, electronic monitor, and many more productivity-boosting features also are standard.



Inching/brake pedal lets you slow travel speed while keeping engine rpm high for optimum hydraulic response and control.

Interior and exterior convex mirrors further enhance the 304J's best-in-class visibility.

Add a highly efficient HVAC system and make your operator even more productive. Automotive-type louvers help keep the view clear, the cab comfortable.



1

1. Walk-through cab lets you enter or exit easily from either side.

2. Boom and bucket control, FNR, and differential lock are on the same low-effort lever for convenient single-handed control.

3. Easy-to-read monitor tracks rpm, time, hours, engine oil pressure, and more. Issues both visible and audible warnings.

4. Low- and high-speed ranges provide infinitely variable travel speeds from standstill to a best-in-class 19 mph.

5. Oscillating axle/elastic articulation reduces cab tilt by as much as 50 percent for a smoother ride that's easier on both machine and operator.



2



3



5



4

Wet-disc brakes in the heavy-duty axles self-adjust and are sealed from moisture and contaminants for long, trouble-free life.

Proportional fan runs only as needed to provide optimal cooling — for reduced wear-and-tear on cooling components, reduced noise, and lower fuel consumption.

Turbocharged Deere PowerTech™ diesel runs quiet and meets EPA Tier 3 non-road emissions regulations. So it can work where rigid sound- and air-quality regulations exist.

Remote test ports enable technicians to quickly troubleshoot problems.



1. Steering linkage is positioned where it's protected, and supported by brackets with easily replaceable wear strips.



2. Angled self-cleaning steps and ergonomically positioned grab bars make getting in and out of the cab easier.



3. A/C condenser tilts out and away from the radiator for easier clean-out. Doesn't require draining fluids or disconnecting hoses.



4. Articulation joints and major structures are so strong and durable, they're covered by a three-year/10,000-hour StructurAll™ warranty.



Built to handle the toughest jobs – yours.

The hard-working 304J limits downtime with its toughness and improves your bottom line with its long-term reliability. Incorporating many of the same features found on our larger loaders, it's built to keep downtime down with sealed electrical connectors, flat-face O-ring seal hydraulic couplings, and self-adjusting

wet-disc brakes. The 304J helps keep your operator out of harm's way, too, with numerous safety features such as an automatic park brake, bypass-start protection, slip-resistant steps, and convenient handholds. If it's uptime you demand, the 304J provides all you and your operator need to stay productive.

If it's not one thing, it's another.



Why invest in a bunch of specialized machines when the highly versatile 304J can do the job? With its standard pin-type hydraulic quick-coupler, the 304J lets you go from bucket to forks, quickly and easily. Or opt for the Worksite Pro™ skid-steer-style coupler that enables this jack-of-all-trades

machine to utilize an even wider array of skid-steer-compatible Worksite Pro attachments. Operation is easy, with joystick and third- and fourth-function pilot controls conveniently located at your fingertips. Regardless of how you equip it, the 304J will be the most versatile compact machine on your worksite.



Change hydraulic flow with a twist of your wrist.

Unobstructed line of sight to attachments makes switchover quick and easy.

The optional fourth-function valve delivers plenty of flow for running hydraulic-driven attachments like power rakes and augers.



1

1. If you change attachments often, you'll appreciate the hydraulic-actuated skid-steer-style coupler that lets you attach and release attachments quickly, without tools or leaving the seat.

Attachments shown:

2. Utility/snow blade
3. Scrap grapple
4. Utility bucket
5. Pallet fork
6. Auger

Available attachments:

- Power rakes
- Utility/snow blades
- Augers
- Bale spears
- Construction or utility buckets
- Tooth buckets
- Pallet forks
- Scrap and brush-tined grapples
- Pick-up brooms



2



3



4



6



5

Fuel-efficient Tier 3 emission-certified John Deere diesel runs 500 hours between oil changes. Hydraulic valve lifters and serpentine belt never require adjustment.

Remote lube bank puts rear axle zerks within easy reach. Convenient maintenance chart helps ensure that nothing gets overlooked.

Locking fuel cap and electrical disconnect switch help prevent theft or vandalism.

Easily accessible maintenance-free batteries are connected in parallel for reliable electrical power.

Easy-lift hood and transverse-mounted engine provide convenient ground-level access to daily checkpoints.



Lower operating costs, raise expectations.

We spared no expense to help keep the 304J's operating costs low. From the transverse-mounted John Deere diesel that provides convenient ground-level service access, to easy-to-change vertical spin-on filters, this versatile loader will

require less of your time and attention. Extended service intervals, environmentally friendly drains, sight gauges — the list of J-Series features that help minimize maintenance go on and on. And so will the daily operating cost savings you'll enjoy.

1. Hydraulically driven fan runs only as needed for efficient cooling, reduced noise, and lower fuel consumption.

2. Easy-access fuse panel accommodates quick checks and changes.

3. Electronic control unit lets service technicians easily retrieve vital operating information and helps diagnose problems more quickly.

4. Hydraulic fluid sight gauge and see-through coolant reservoir let you check fluid levels at a glance.

5. Easy access vertical spin-on filters and environmental drains make fluid changes quicker and cleaner.

6. Nobody backs you better than the 400-plus John Deere dealers throughout North America.



Specifications

Engine **304J**

Manufacturer and Model	John Deere PowerTech™ 5030T
Non-Road Emission Standards	certified to EPA Tier 3 emissions
Cylinders	5
Valves per Cylinder	2
Displacement	184 cu. in. (2.9 L)
Net Rated Power @ 2,800 rpm, SAE	.73 hp (54 kW)
Net Peak Power @ 2,800 rpm, SAE	.75 hp (56 kW)
Maximum Net Torque @ 1,500 rpm	195 lb.-ft. (265 Nm)
Lubrication	pressure system with full-flow spin-on filter
Fuel System	electronically controlled unit injection pump
Aspiration	turbocharged
Air Cleaner	dual safety element dry type

Cooling

Hydraulically driven, proportionally controlled fan	
Engine Coolant Rating	-34 deg. F (-37 deg. C)

Powertrain

Hydrostatic (HST) with infinitely variable speed control over full range of operating speeds; two speed ranges; joystick-mounted F-N-R; acceleration pedal; HST inching pedal, which allows infinitely reduced travel speeds while maintaining full engine rpm and hydraulic flow	
Two Travel Speeds In Forward and Reverse (equipped with 405/70R20 tires)	
Gear 1	4.3 mph (6.9 km/h)
Gear 2	18.6 mph (29.9 km/h)
Axles	rear center-pivot axle with 10-deg. rear axle oscillation and 10-deg. frame oscillation
Rear Axle Oscillation Versus Front Axle	20 deg. total, stop to stop
Differentials	manual (push-button) locking front, conventional rear
Maximum Rise and Fall, Single Wheel	11 in. (290 mm)
Steering	hydraulic power steering (SAE J1511); 26-deg. rear-wheel steering tied mechanically to articulation; equivalent of 97-deg. conventional steering system articulation
Articulation Angle	56-deg. arc (28 deg. each direction)
Final Drive	heavy-duty outboard planetary
Brakes (SAE J1473 and ISO 3450)	
Service Brakes	hydraulically actuated, self-adjusting internal wet-disc brake and driveline drum brake
Parking Brake	automatically spring-applied, hydraulically released, internal wet disc

Hydraulics

Main Pump (loader and steering)	fixed-displacement gear pump; open-center system
Maximum Rated Flow @ 1,000 psi (6895 kPa)	25 gpm (95 L/m)
System Relief Pressure (loader and steering)	2,750 psi (18 961 kPa)
Hydraulic Cycle Times	
Raise	5.3 sec.
Dump	1.6 sec.
Lower	
Float Down	4.5 sec.
Power Down	6.3 sec.
Total	13.2 sec.
Maximum Lift Capacity	with 1.4-cu.-yd. (1.1 m ³) stockpiling/general-purpose bucket with bolt-on cutting edge
Lift at Ground Level	12,136 lb. (5510 kg)
Lift at Maximum Height	7,868 lb. (3572 kg)
Turning Radius	
Measured to Centerline of Outside Tire	12 ft. 5 in. (3.78 m)
Controls	pilot-operated, 3-function valve with single-lever control for boom and bucket, and auxiliary level for standard pin disconnect and auxiliary hydraulics, with control-lever lockout feature; optional additional 4-function valve with push-button control

Electrical

304J

Electrical load center with blade-type multi-fused circuits	
Voltage	12 volt
Battery Capacity	1,700 CCA
Reserve Capacity	160 min.
Alternator Rating	.65 amp
Lights (SAE 99)	driving/front working lights (2), turn signals, flashers, stop- and taillights

Tires/Wheels

	Tread Width	Width Over Tires	Change In Vertical Height
Standard-Size, 405/70R20 Tires on Single-Piece Rims	.654 in. (1661 mm)	81.7 in. (2075 mm)	0 in. (0 mm)

Serviceability

Refill Capacities

Cooling System (engine and radiator)	12.7 qt. (12.0 L)
Differential and Planetary Axle	
Front	7.7 qt. (7.3 L)
Rear	7.1 qt. (6.7 L)
Engine Oil with Filter	11.9 qt. (11.0 L)
Fuel Tank	21.5 gal. (81.0 L)
Hydraulic/Hydrostatic Reservoir with Filter	21.1 gal. (80.0 L)
Hydrostatic Motor Gearbox	0.8 qt. (0.8 L)
Front/Rear Axle Planetary Hubs (each)	0.9 qt. (0.9 L)

Operating Weights

With standard equipment, 405/70R20 tires, standard counterweight, cab, 175-lb. (79 kg) operator, and full fuel tank

With Quick-Coupler and 1.4-cu.-yd.

(1.1 m³) Stockpiling/General-Purpose

Bucket with Bolt-On Edge 13,404 lb. (6080 kg)

With Quick-Coupler and Fork. 13,058 lb. (5923 kg)

Optional Components

Bucket, 1.4 cu. yd. (1.1 m³), Stockpiling/General Purpose 946 lb. (429 kg)

Machine Dimensions

DIMENSIONS WITH QUICK-COUPLER AND BUCKET

A Height to Top of Cab	.9 ft. 2 in. (2.79 m)
B Height to Top of Exhaust	.8 ft. 9 in. (2.67 m)
C Ground Clearance	15.2 in. (386 mm)
D Length from Centerline of Front Axle	29.5 in. (749 mm)
E Wheelbase	7 ft. 7 in. (2.30 m)
F Dump Clearance, 42-deg. Full Height	▲ (see page 16)
G Height to Hinge Pin, Fully Raised	11 ft. 0 in. (3.35 m)
H Dump Reach, 42-deg., 7-ft. (2.13 m) Clearance	▲▲ (see page 16)
I Maximum Digging Depth	2.7 in. (69 mm)
J Overall Length	▲▲▲ (see page 16)
K Maximum Rollback at Full Height	.56 deg.
L Bucket Dump at Full Height	.42 deg.
M Maximum Rollback at Ground Level	.40 deg.

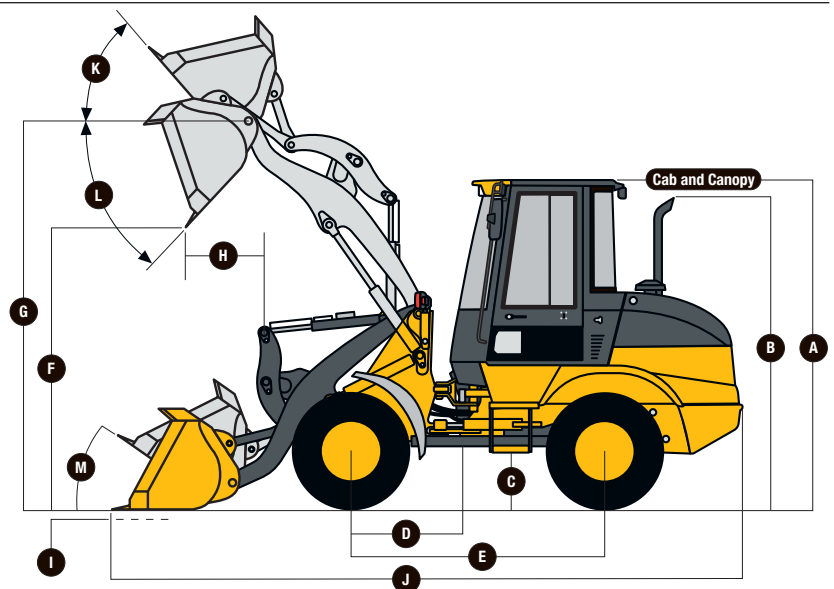

Machine Dimensions (continued) 304J

DIMENSIONS WITH QUICK-COUPLER AND FORK

- A** Reach, Fully Raised 22.4 in. (569 mm)
 - B** Fork Height, Fully Raised 10 ft. 6 in. (3.19 m)
 - C** Maximum Reach, Fork Level 5 ft. 0 in. (1.52 m)
 - D** Fork Height, Maximum Reach 4 ft. 6 in. (1.36 m)
 - E** Reach, Ground Level 29.5 in. (749 mm)
 - F** Depth Below Ground 1.4 in. (36 mm)
 - G** Tine Length 3 ft. 11 in. (1.20 m)
 - H** Overall Length 20 ft. 2 in. (6.14 m)
- As Measured with Fork Level, Load Centered on Tine
- Tipping Load, Straight 7,877 lb. (3573 kg)
 - Tipping Load, Full Turn 7,165 lb. (3250 kg)

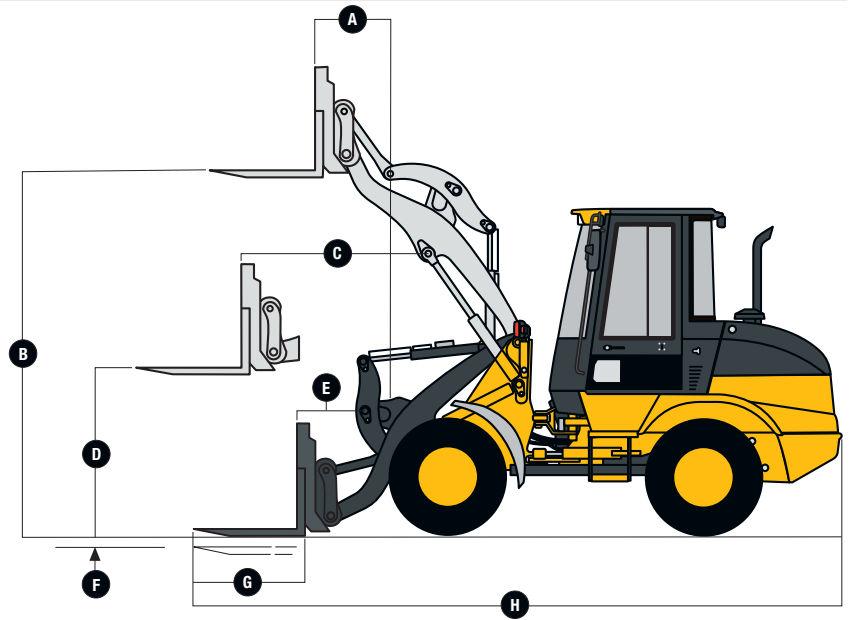

Standard Z-Bar Pin-On Bucket

- | Bucket Type/Size | <i>Stockpiling/General Purpose w/Bolt-on Edge</i> |
|----------------------------------------------------------|---------------------------------------------------|
| Capacity, Heaped SAE | 1.4 cu. yd. (1.1 m ³) |
| Capacity, Struck SAE | 1.2 cu. yd. (0.9 m ³) |
| Bucket Width | 7 ft. 3 in. (2.20 m) |
| Breakout Force, SAE J732C | 12,364 lb. (5608 kg) |
| Tipping Load, Straight | 10,241 lb. (4645 kg) |
| Tipping Load, Full Turn, SAE | 9,315 lb. (4225 kg) |
| ▲▲ Reach, 42-Deg. Dump, 7-ft. (2.13 m) | |
| Clearance | 4 ft. 3 in. (1.30 m) |
| ▲▲ Reach, 42-Deg. Dump, Full Height | 34.8 in. (884 mm) |
| ▲ Dump Clearance, 42 Deg., Full Height | 8 ft. 9 in. (2.67 m) |
| ▲▲▲ Overall Length, Bucket on Ground | 18 ft. 11 in. (5.76 m) |
| Loader Clearance Circle, Bucket Carry Position | 27 ft. 3 in. (8.30 m) |

Loader operating information is based on machine with standard equipment, 405/70R20 tires, standard counterweight, cab, 175-lb. (79 kg) operator, and full fuel tank. This information is affected by tire size, ballast, and different attachments.

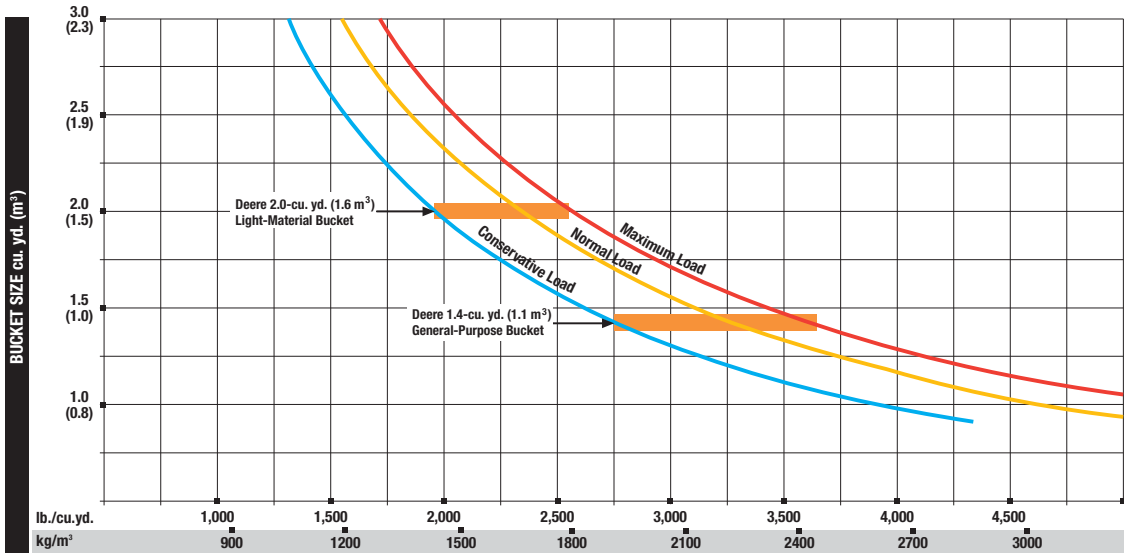

LOOSE MATERIALS	lb./cu. yd.	kg/m ³
Chips, pulpwood	486	288
Cinders (coal, ashes, clinkers)	1,134	673
Clay and gravel, dry	2,700	1602
Clay, compact, solid	2,943	1746
Clay, dry in lump loose	1,701	1009
Clay, excavated in water	2,160	1282
Coal, anthracite, broken, loose	1,458	865
Coal, bituminous, moderately wet	1,350	801
Earth, common loam, dry	2,052	1218
Earth, mud, packed	3,105	1843
Granite, broken	2,592	1538
Gypsum	3,834	2275
Limestone, coarse, sized	2,646	1570
Limestone, mixed sizes	2,835	1682
Limestone, pulverized or crushed	2,295	1362
Sand, damp	3,510	2083
Sand, dry	2,970	1762
Sand, voids, full of water	3,510	2083
Sandstone, quarried	2,214	1314
Shale, broken crushed	2,295	1362
Slag, furnace granulated	3,294	1955
Stone or gravel, 1-1/2" to 3-1/2" size	2,430	1442
Stone or gravel, 3/4" size	2,700	1602

*This guide, representing bucket sizes not necessarily manufactured by Deere, will help you in selecting proper bucket size for material density, loader configuration, and operating conditions. Optimum bucket size is determined after adding or subtracting all tipping load changes due to optional equipment. The "conservative load" line on this guide is recommended when operating in conditions such as soft ground and uneven surfaces. The "maximum load" condition on this guide is sometimes utilized when operating on firm ground and level surfaces.

304J LOADER

Key: ● Standard equipment ▲ Optional or special equipment

304J Engine

- Certified to EPA Tier 3 emissions
- Antifreeze, -34°F (-37°C)
- Coolant recovery tank
- Fan safety guard
- Fan, suction type, hydraulically driven, proportional speed
- Muffler, under hood with curved end exhaust stack
- Environmentally friendly engine oil drain
- Spin-on engine oil and fuel filter
- Engine oil cooler
- Quick-release fuel filter and water separator
- Under-hood dual-element air cleaner with restriction indicator
- Under-hood prescreened air intake with dust evacuator valve
- Serpentine drive belt with automatic tensioner
- ▲ Engine coolant heater, 1,000 watts, 110 volts
- ▲ Special application: Trash screens, etc.*

Electrical

- Starter switch with electric fuel cutoff
- 12-volt system
- Electrical load center with blade-type fuses
- Standard batteries (2), 12 volt with 1,700 CCA
- Master electrical disconnect switch
- Alternator, 12 volts, 65 amps
- Horn (conforms to SAE J994, J1446)
- Lights (conform to SAE 99): Driving / Front working (2) / Turn signals / Flashers / Stop / Taillights
- Pre-wired for rear worklights
- ▲ Worklights, rear (2)
- Reverse warning alarm (conforms to SAE J994, J1446)
- Multifunction monitor with audible and visual warnings: Low engine oil pressure / Engine coolant temperature / HST transmission oil temperature / Parking brake indicator / Gauges and indicators: Engine coolant temperature, fuel level, speedometer, clock, and hour meter
- Indicator lights: Engine air filter / Fasten seat belt / Parking brake actuated / Forward/reverse travel / 1st or 2nd speed range / Turn signal and hazard lights / High-beam indicator / Battery voltage

304J Electrical (continued)

- Radio-ready cab, fused 12-volt radio electrical lead and speakers, power port
- By-pass starter safety cover on starter, positive terminal battery cover
- Pre-wired for roof beacon
- Sealed external electrical connectors

Powertrain/Brakes

- Hydrostatic (HST) transmission: Electric shift control / Single-lever joystick F-N-R / Hydrostatic oil cooler / Inching pedal / Two speeds forward and reverse / Infinitely variable speed control
- Service brakes, hydraulically actuated, self-adjusting internal wet-disk brake and driveline drum brake
- Parking brake, spring applied, hydraulically released, switch operated
- Axles, manual locking front and conventional rear differentials, heavy-duty outboard planetaries

Hydraulic System

- Hydraulic system oil cooler
- Automatic bucket return-to-dig control
- Boom float function
- Reservoir sight gauge for hydraulic/hydrostatic oil
- Fine-micron hydraulic filter, vertical mounting
- Hydraulic lever lockout
- Pilot-operated three-function valve with single joystick lever control for boom and bucket, and auxiliary lever for standard pin disconnect and auxiliary hydraulics
- ▲ Four-function hydraulic valve with pilot joystick control and pilot auxiliary lever for third function, and push buttons for fourth function
- ▲ Hydraulic conversion kits, four-function valve
- Quick-coupler diagnostic ports: Priority pressure / Hydraulic pump pressure / Control valve pressure / HST pressure

Operator's Station

- Cab (conforms to SAE J1040, SAE J231, ISO3471, ISO3449): ROPS/FOPS / Heater/defroster / Rubber-plane isolation mounted for noise/vibration reduction / Intermittent front and rear windshield

*See your John Deere dealer for further information.

304J Operator's Station (continued)

- wipers and washers / Tinted safety glass / Full-width adjustable sun visor / Pre-wired for radio speakers / Deluxe high-back cloth seat with mechanical and 2-inch (51 mm) retractable seat belt / Left and right doors / One sliding window in each door
- ▲ AM/FM/WB radio
- ▲ AM/FM/WB radio with cassette player
- ▲ AM/FM/WB radio with CD player
- ▲ Air conditioning (factory or dealer installed)
- Storage compartment
- Rubber floor mat
- Tilt steering column
- Rearview mirrors, outside (2) and inside (1) (conform to SAE J985)
- Handholds and steps, ergonomically located and slip resistant (conform to SAE J185)

Loader Linkage

- Z-bar loader linkage
- Loader boom service locking bar (conforms to SAE J38)

Buckets and Attachments

- ▲ Full line of buckets with selection of bolt-on cutting edges and teeth
- Standard quick-coupler, less bucket
- ▲ Worksite Pro™ skid-steer-style coupler
- ▲ Full line of construction utility forks, pallet forks, extendible boom with hook, and other attachments*

Tires

- 405/70R20 tires on single-piece rims

Other

- Fenders, front and rear
- Articulation locking bar (conforms to SAE J276)
- Vandal protection, includes lockable engine enclosure and fuel fill
- Counterweight, full
- Rear bottom guard
- Drawbar, with locking pin
- ▲ Material-weighing system*
- ▲ Ride control
- ▲ JDLINK™ wireless communication system

CONTROL OWNING AND OPERATING COSTS

Customer Personal Service (CPS) is part of John Deere's proactive, fix-before-fail strategy on machine maintenance that will help control costs, increase profits, and reduce stress. Included in this comprehensive lineup of ongoing programs and services are:

Fluid analysis program – tells you what's going on inside *all* of your machine's major components so you'll know if there's a problem *before* you see a decline in performance. Fluid analysis is included in most extended coverage and preventive-maintenance agreements.

Component life-cycle data – gives you vital information on the projected life span of components and lets you make informed decisions on machine maintenance by telling you approximately how many hours of use you can expect from an engine, transmission, or hydraulic pump. This information can be used to preempt catastrophic downtime by servicing major components at about 80 percent of their life cycle.

Preventive Maintenance (PM) agreements – give you a fixed cost for maintaining a machine for a given period of time. They also help you avoid downtime by ensuring

that critical maintenance work gets done right and on schedule. On-site preventive maintenance service performed where and when you need it helps protect you from the expense of catastrophic failures and lets you avoid waste-disposal hassles.

Extended coverage – gives you a fixed cost for machine repairs for a given period of time so you can effectively manage costs. Whether you work in a severe-service setting or just want to spread the risk of doing business, this is a great way to custom-fit coverage for your operation. And an extended coverage contract also travels well because it's backed by John Deere and is honored by *all* Deere construction dealers.

Customer Support Advisors (CSAs) – Deere believes the CSA program lends a *personal* quality to Customer Personal Service (CPS). Certified CSAs have the knowledge and skills for helping make important decisions on machine maintenance and repair. Their mission is to help you implement a plan that's right for *your* business and take the burden of machine maintenance off your shoulders.



JOHN DEERE
DKA304J Litho in U.S.A. (09-03)

Net engine power is with standard equipment including air cleaner, exhaust system, alternator, and cooling fan, at standard conditions per SAE J1349 and DIN 70 020, using No. 2-D fuel at 35 API gravity. No derating is required up to 5,000-ft. (1500 m) altitude. Gross power is without cooling fan.

Specifications and design subject to change without notice. Wherever applicable, specifications are in accordance with SAE standards. Except where otherwise noted, these specifications are based on a unit with all standard equipment, 405/70R20 tires, ROPS cab, full fuel tank, and 175-lb. (79 kg) operator.

