



AD-75V / AD-758V Parts Manual

Phase 7 / Dual Timer / OPL with
Fire Suppression System Options

American Dryer Corporation
88 Currant Road
Fall River, MA 02720-4781
Telephone: (508) 678-9000 / Fax: (508) 678-9447
E-mail: techsupport@amdry.com

www.amdry.com

Retain This Manual In A Safe Place For Future Reference

American Dryer Corporation products embody advanced concepts in engineering, design, and safety. If this product is properly maintained, it will provide many years of safe, efficient, and trouble free operation.

ONLY qualified technicians should service this equipment.

OBSERVE ALL SAFETY PRECAUTIONS displayed on the equipment or specified in the installation manual included with the dryer.

The following “**FOR YOUR SAFETY**” caution must be posted near the dryer in a prominent location.

FOR YOUR SAFETY

Do not store or use gasoline or other flammable vapors and liquids in the vicinity of this or any other appliance.

POUR VOTRE SÉCURITÉ

Ne pas entreposer ni utiliser d'essence ni d'autres vapeurs ou liquides inflammables à proximité de cet appareil ou de tout autre appareil.

We have tried to make this manual as complete as possible and hope you will find it useful. ADC reserves the right to make changes from time to time, without notice or obligation, in prices, specifications, colors, and material, and to change or discontinue models.

Important

For your convenience, log the following information:

DATE OF PURCHASE _____ **MODEL NO.** _____

RESELLER'S NAME _____

Serial Number(s) _____

Replacement parts can be obtained from your reseller or the ADC factory. When ordering replacement parts from the factory, you can FAX your order to ADC at (508) 678-9447 or telephone your order directly to the ADC Parts Department at (508) 678-9000. Please specify the dryer model number and serial number in addition to the description and part number, so that your order is processed accurately and promptly.

The illustrations on the following pages may not depict your particular dryer exactly. The illustrations are a composite of the various dryer models. Be sure to check the descriptions of the parts thoroughly before ordering.

“IMPORTANT NOTE TO PURCHASER”

Information must be obtained from your local gas supplier on the instructions to be followed if the user smells gas. These instructions must be posted in a prominent location near the dryer.

Table of Contents

Phase 7 OPL Control Door Assembly	4
Coin Control Door Assembly	5
Dual Timer OPL Control Door Assembly	6
Phase 7 OPL Microprocessor Control Panel Assembly	7
Phase 7 Coin Microprocessor Control Panel Assembly	8
Dual Timer "Tap Touch" Controls	9
Phase 7 Microprocessor Control Box Assembly	10
Coin Vault Assembly	11
Dual Timer Control Box Assembly	12
Front Panel Assembly	13
37-1/4" Main Door Assembly for Models Mfd. as of September 11, 2006	14
25-1/2" Main Door Assembly for Models Mfd. prior to September 11, 2006	15
Main Door Switch Assembly for Models Mfd. as of September 11, 2006	16
Main Door Switch Assembly for Models Mfd. prior to September 11, 2006	17
Tumbler / Support Assemblies	18
Lint Drawer / Lint Drawer Switch Assembly	19
Idler Bearing Assembly	20
Tumbler Bearing Assembly	21
Non-Reversing Motor Mount Assembly	22
Reversing Motor Mount Assembly	24
Sensor Bracket Assemblies	26
Direct Spark Ignition Burner Assembly	28
Direct Spark Ignition Burner CE Assembly	30
Electric Oven Assembly	32
Sail Switch Assembly	34
Single-Phase (1 \emptyset) Microprocessor Rear Electric Relay Panel Assembly	35
208-240V 3-Phase (3 \emptyset) Microprocessor Rear Electric Relay Panel Assembly	36
460-480V Microprocessor Rear Electric Relay Panel Assembly	37
208-240V Microprocessor Reversing Rear Electric Relay Panel Assembly	38
460-480V Microprocessor Reversing Rear Electric Relay Panel Assembly	39
Single-Phase (1 \emptyset) Dual Timer Rear Electric Relay Panel Assembly	40
460-480V Dual Timer Rear Electric Relay Panel Assembly	42
208-240V Dual Timer Reversing Rear Electric Relay Panel Assembly	43
Air-Operated Steam Damper Assembly	44
Fire Suppression System Assemblies	46
Outer Top / Back Guard Assemblies for Models Mfd. as of January 5, 2003	47
Outer Top / Back Guard Assemblies for Models Mfd. prior to January 5, 2003	48
Microprocessor Electric Oven Component Application Chart	49
Dual Timer Electric Oven Component Application Chart	50
Additional Parts Available	51

Phase 7 OPL Control Door Assembly

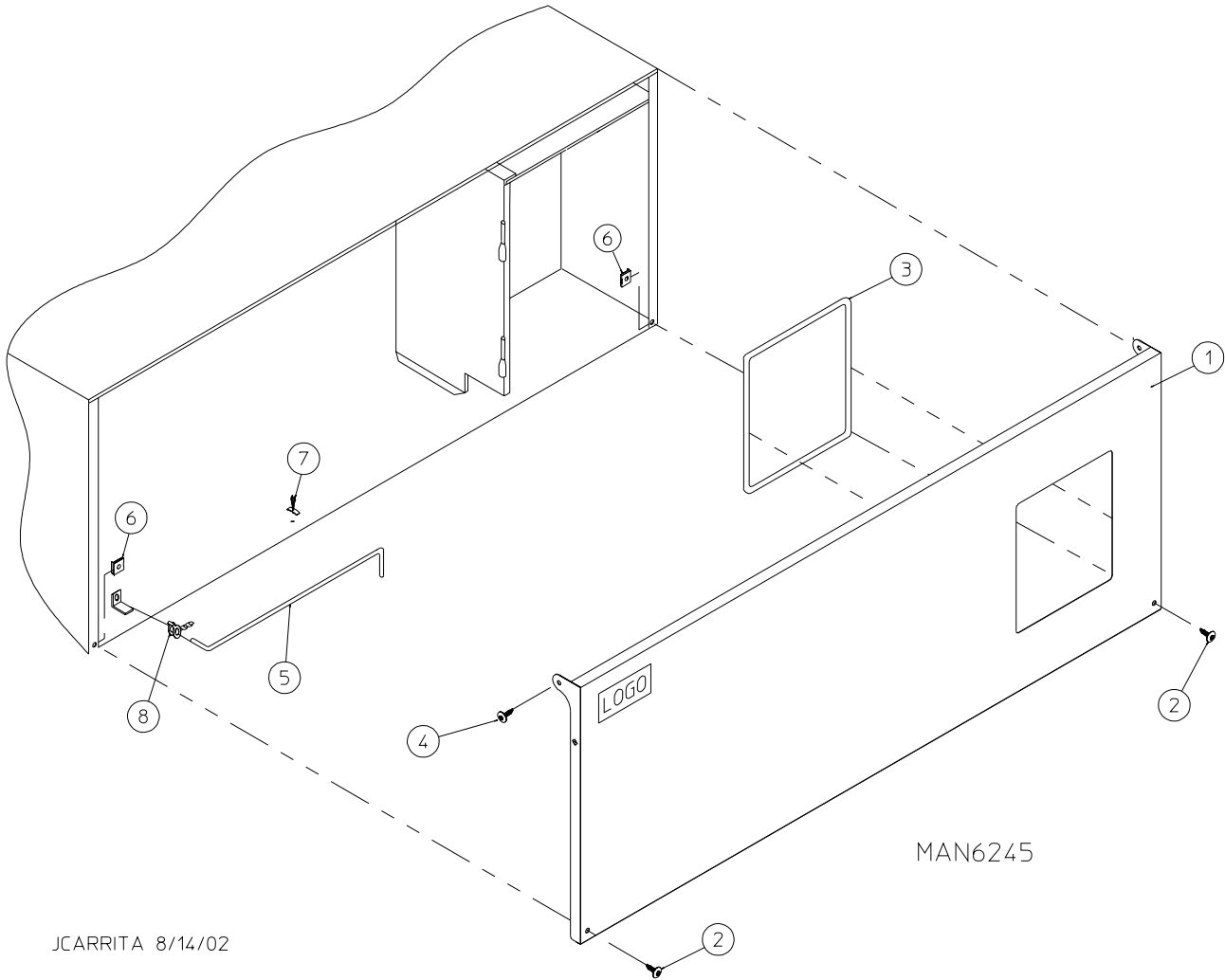

JCARRITA 8/14/02

<u>Illus. No.</u>	<u>Part No.</u>	<u>Qty.</u>	<u>Description</u>
1	883758	1	White OPL Control Door (includes illus. nos. 1 and 3)
	883756	1	Ivory OPL Control Door (includes illus. nos. 1 and 3)
	883759	1	Coral Blue OPL Control Door (includes illus. nos. 1 and 3)
2	150321	2	#10-32 x 1/2" Phillips Machine Screw
3	117604	4	Noise Suppression Tape (sold by the foot)
4	150317	2	#10-16 x 3/4" TORX PLUS® BTN, Type 1
5	102503	1	Control Door Support Rod
6	154011	2	#10-32 Multi-Thread U-Nut
7	102603	1	Control Door Rod Support Catch
8	102601	1	Control Door Rod Retainer Clip

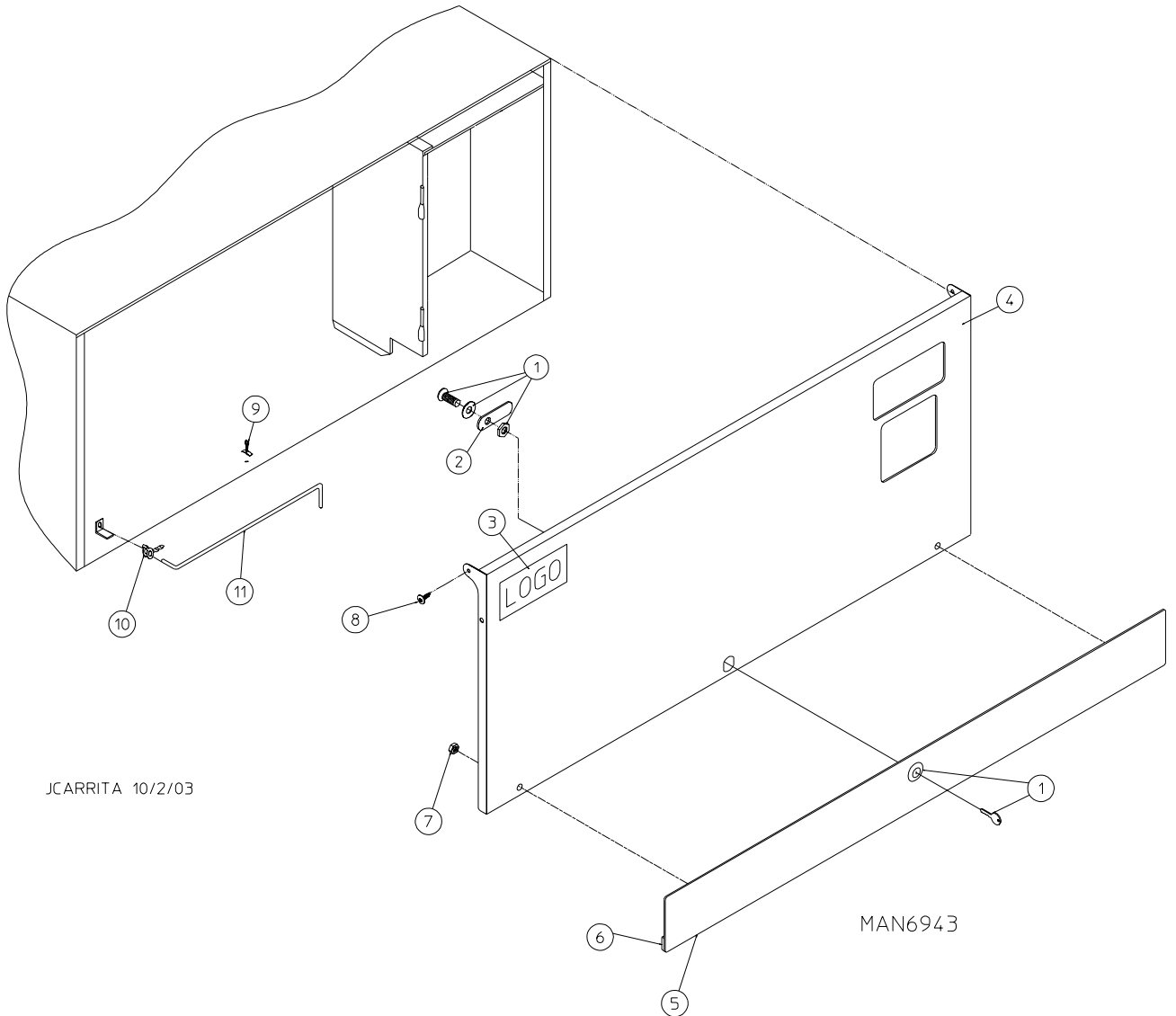

<u>Illus. No.</u>	<u>Part No.</u>	<u>Qty.</u>	<u>Description</u>
1	160015	1	High Security MK-100 Lock Assembly with Key
	160104	1	MK-100 Key ONLY
2	160032	1	Lock Cam ONLY
3	881053	1	ADC Logo with Tape
4	817246*	1	Control Door Assembly with Black Trim (includes illus. nos. 4 through 7)
5	817164	1	Black Trim
6	117604	6	Neoprene Sponge Tape (sold by the foot)
7	152014	4	1/4-20 Free Spin Wash Nut
8	150317	2	#10-16 x 3/4" TORX PLUS® BTN, Type 1
	150318	1	TORX PLUS® Bit
9	102603	1	Control Door Support Rod Catch
10	102601	1	Control Door Rod Retainer Clip
11	102503	1	Control Door Support Rod

* Specify color when ordering.

Dual Timer OPL Control Door Assembly

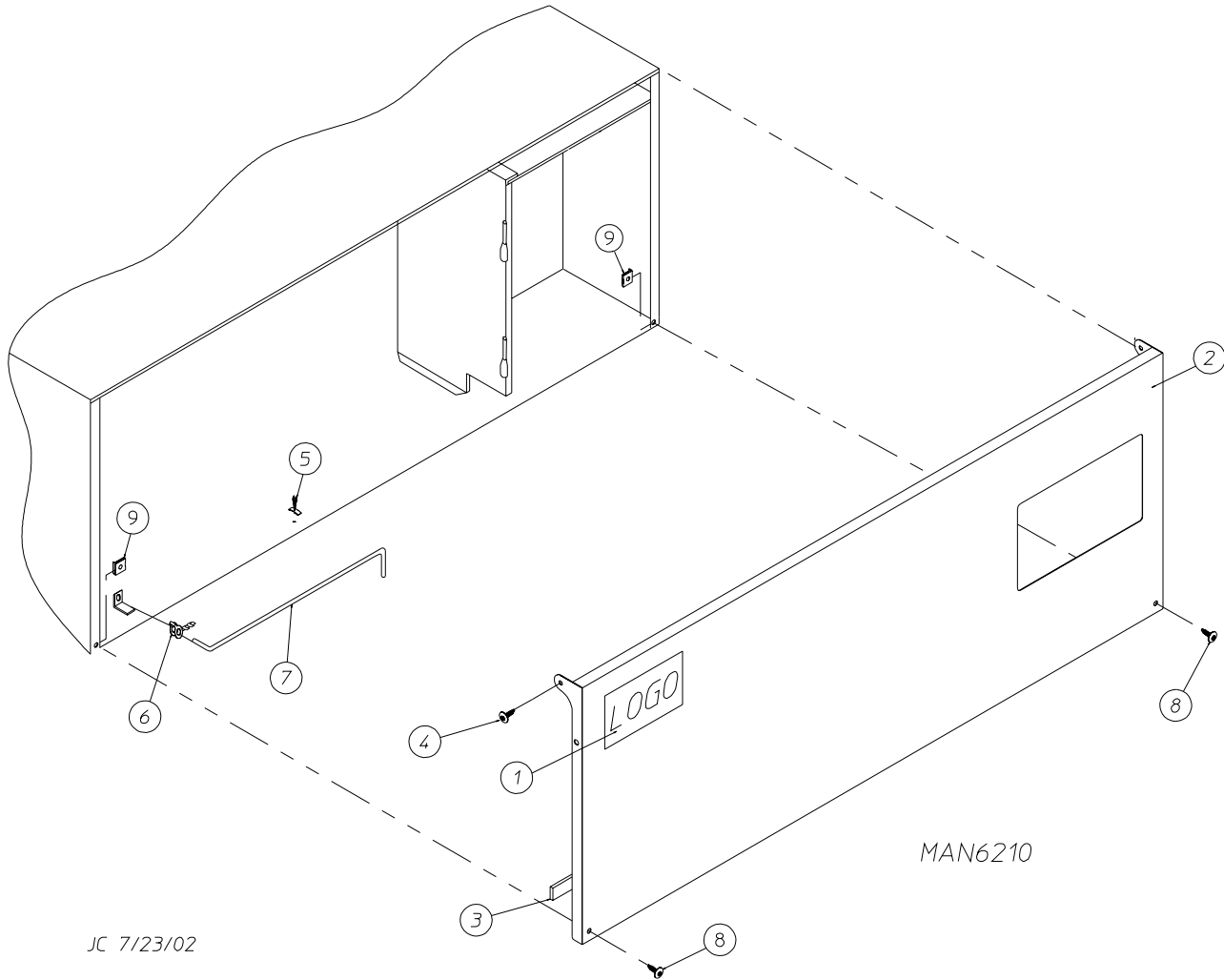

JC 7/23/02

1	881053	1	ADC Logo with Tape
	870011	1	Double Sided Tape Kit
2	883616	1	White Control Door Assembly (includes illus. nos. 2 and 3)
	883618	1	Ivory Control Door Assembly (includes illus. nos. 2 and 3)
	883617	1	Coral Blue Control Door Assembly (includes illus. nos. 2 and 3)
3	117604	3	Noise Suppression Tape (sold by the foot)
4	150317	2	#10-16 x 3/4" TORX PLUS® BTN, Type 1
5	102603	1	Control Door Rod Support Catch
6	102601	1	Control Door Rod Retainer Clip
7	102503	1	Control Door Support Rod
8	150321	2	#10-32 x 1/2" Phillips Machine Screw
9	154011	2	#10-32 Multi-Thread U-Nut

Phase 7 OPL Microprocessor Control Panel Assembly

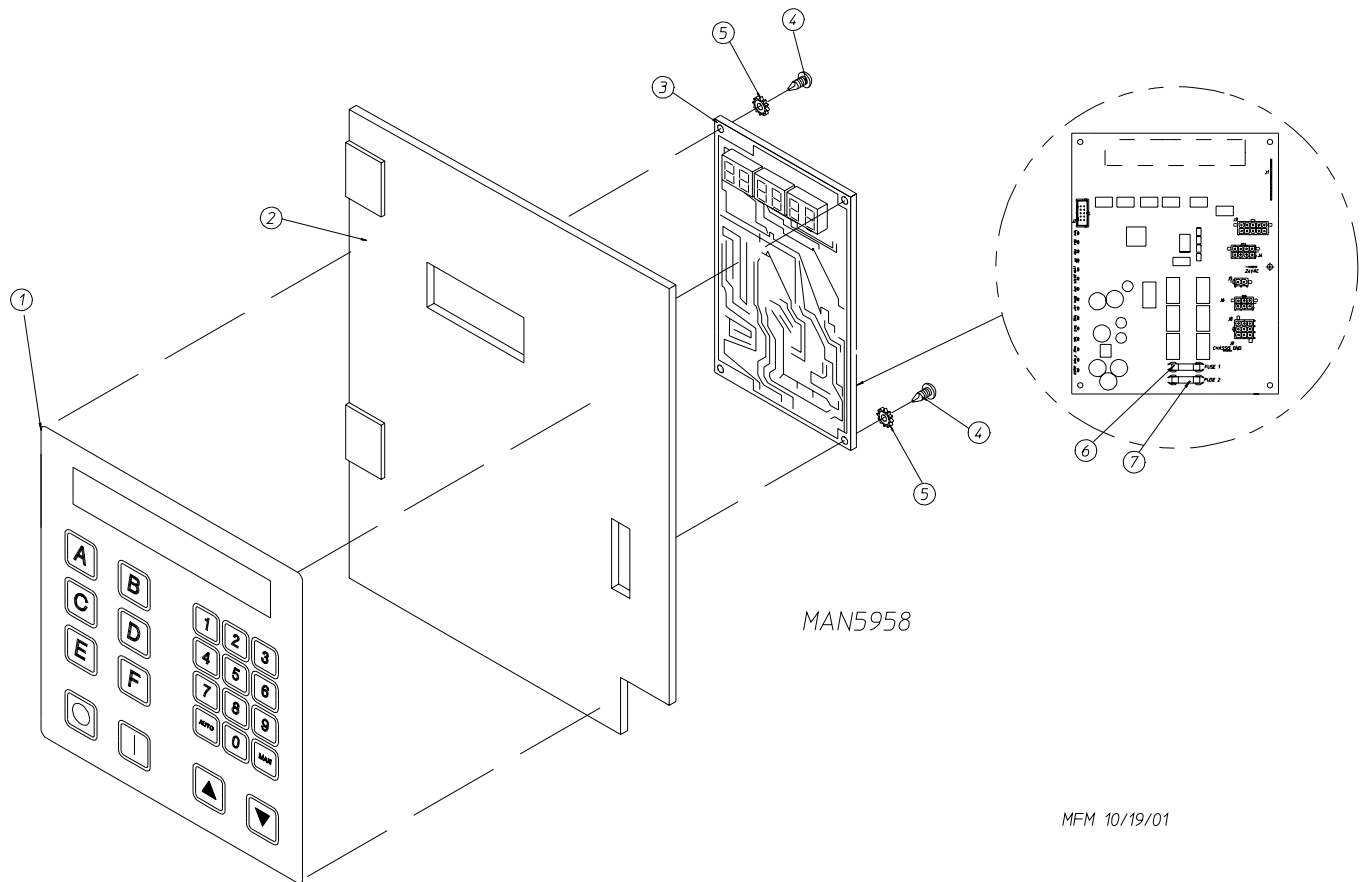

Illus. No.	Part No.	Qty.	Description
1	112577	1	Phase 7 OPL Keypad
2	850984	1	Phase 7 OPL Microprocessor Controller (computer) Panel ONLY
3	887003	1	Phase 7.2.2 Board with Fire Suppression System and H ₂ O (pressure) Switch
	887000		Phase 7.2.2 Board with Fire Suppression System and no H ₂ O (pressure) Switch
	887023		Phase 7.2.2 Board "Dutch" and "Polish" with Fire Suppression System and H ₂ O Pressure Switch
	887024		Phase 7.2.2 Board without Fire Suppression System
4	150005	2	#6-32 x 3/4" Phillips Round Head Machine Screw
5	153010	2	#6 Star Washer
6	136097	1	500 mA Fuse
7	136016	1	5-Amp Fuse

Phase 7 Coin Microprocessor Control Panel Assembly

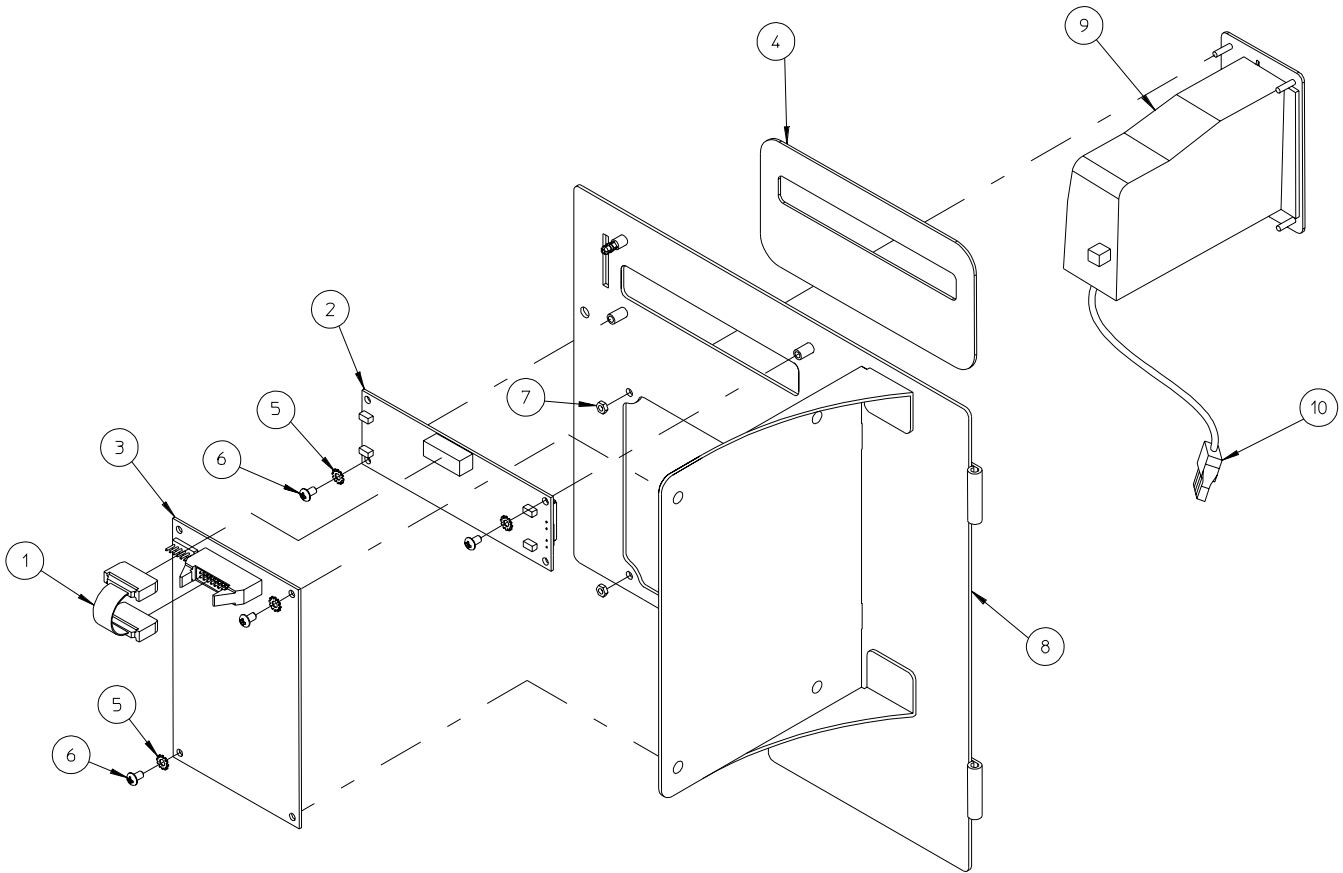

JCARRITA 10/17/02

MAN6308

Illus. No.	Part No.	Qty.	Description
1	137250	1	Phase 7 Coin Ribbon Cable
2	137270	1	16" x 1" Large Character Display
3	887007	1	Phase 7 Coin Board (for models without Fire Suppression System)
	887009	1	Phase 7 Coin Board (for models with Fire Suppression System)
	887012	2	Phase 7 Coin Board (for models mfd. with Fire Suppression System and H ₂ O switch)
4	112575	1	Phase 7 Keypad
5	153010	4	#6 Internal and External Star Washers
6	150005	4	#6-32 x 1/4" Phillips Round Head Machine Screw
7	152102	4	M3 Metric Hex Nut
8	823145	1	Phase 7 Coin Control Panel ONLY
9	818232	1	Phase 7 25¢ Coin Acceptor Assembly
	830159		Phase 7 Programmable Euro Coin Acceptor Assembly
	830136		Phase 7 Programmable Shekel Coin Acceptor Assembly
	830006		Phase 7 Programmable NZD / AUD / HKD Coin Acceptor Assembly
10	122633	1	3-Pin Connector

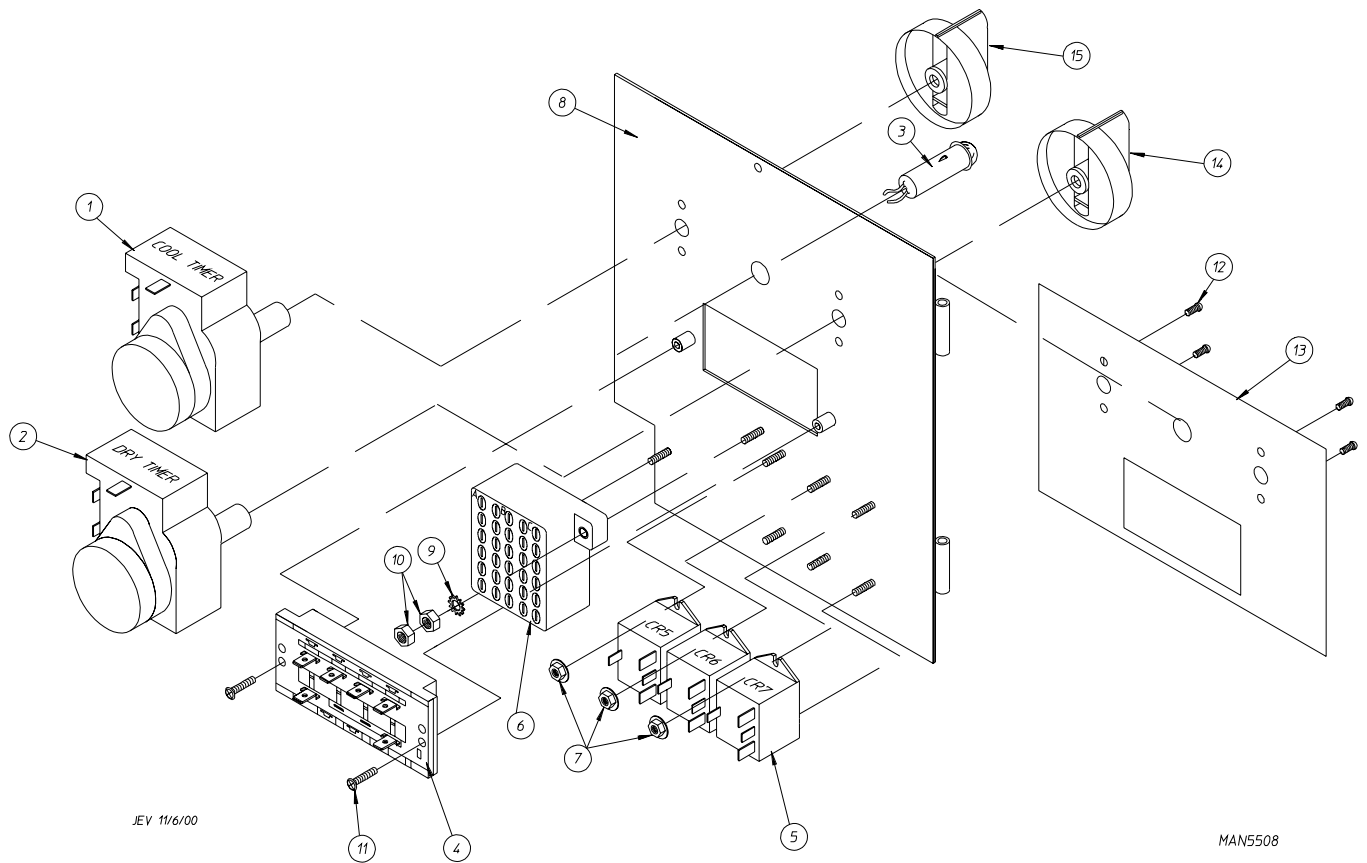

Illus. No.	Part No.	Qty.	Description
1	824298	1	15 Minute Timer – 24 VAC
2	824299	1	60 Minute Timer – 24 VAC
3	824175	1	Red Pilot Light – 24 VAC
4	122301	1	"Tap Touch" Switch
5	131932	3	Relay SPST 24v
6	120730	1	30-Position Terminal Block
7	151000	6	#6-32 Pal Nut
8	882903	1	Dual Timer Panel Complete (includes illus. nos. 1 through 15)
	850392	–	Dual Timer Panel ONLY
9	153010	2	#6 Star Washer
10	152000	3	#6-32 Hex Nut
11	150207	2	#10-24 x 1/2" Phillips Pan Head Machine Screw
12	150110	4	#8-32 x 1/4" Phillips Round Head Machine Screw
13	112563	1	Dual Timer Panel Overlay
14	124104	1	Pure Touch Knob with Red Pointer
15	124105	1	Pure Touch Knob with Blue Pointer

Phase 7 Microprocessor Control Box Assembly

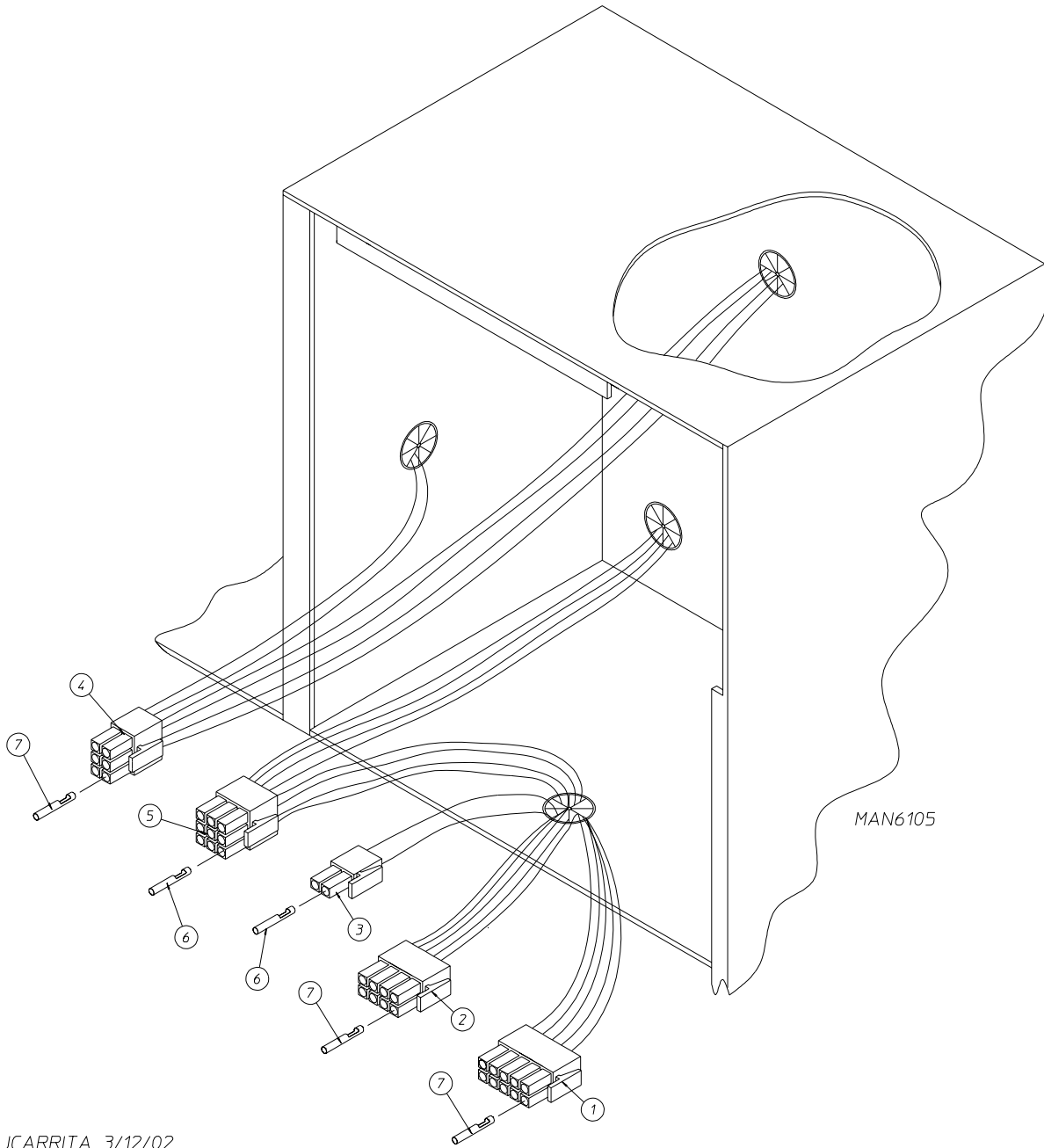

JCARRITA 3/12/02

<u>Illus. No.</u>	<u>Part No.</u>	<u>Qty.</u>	<u>Description</u>
1	122681	1	10-Pin Connector
2	122676	1	8-Pin Connector
3	122646	1	2-Pin Connector
4	122683	1	6-Pin Connector (OPL computer Only)
5	122640	1	9-Pin Connector
6	122706	*	#20-16 U.M.N.L. Socket
7	122669	*	Female Crimp Terminal

* As needed.

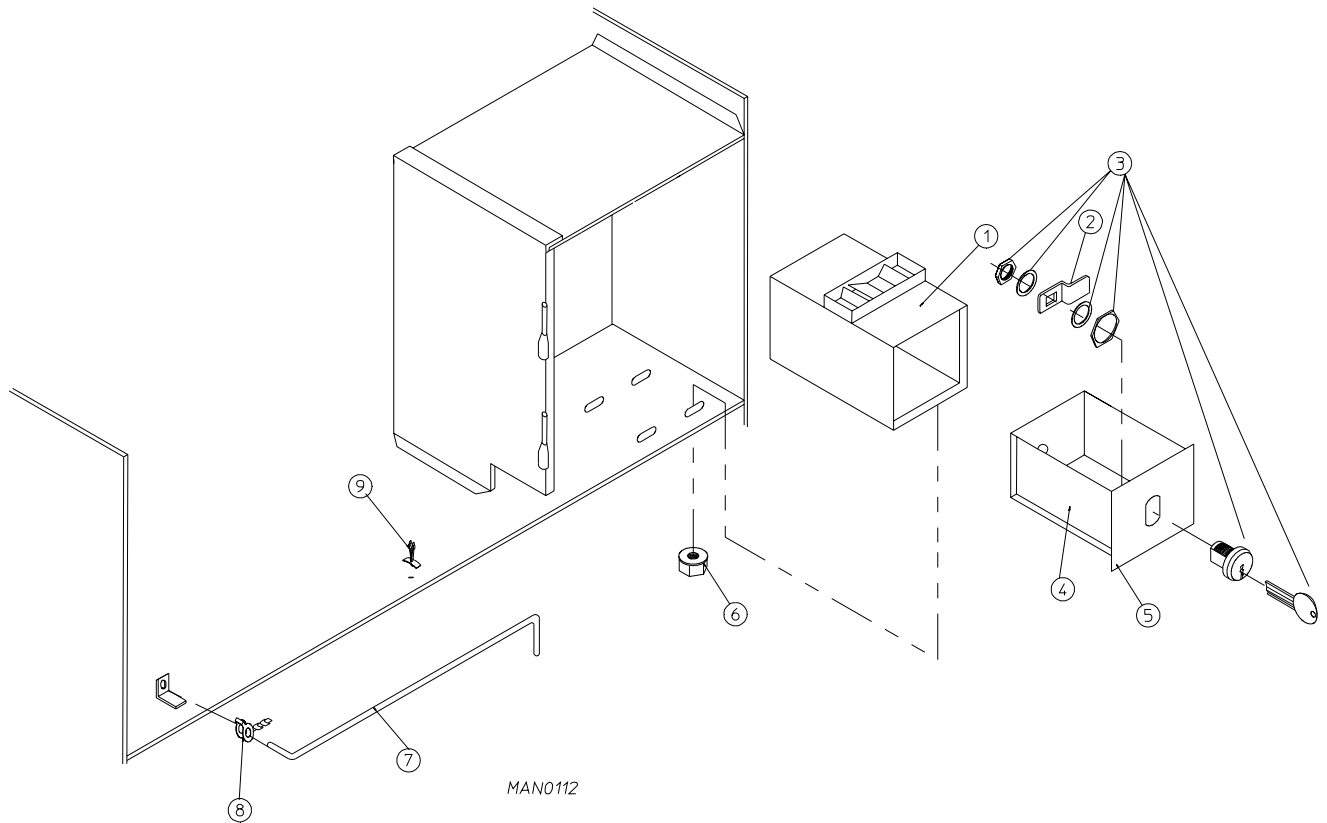

<u>Illus. No.</u>	<u>Part No.</u>	<u>Qty.</u>	<u>Description</u>
1	884050	1	Microprocessor Coin Vault Assembly Complete (includes illus. nos. 1 through 6)
	823143	1	Microprocessor Coin Vault ONLY
2	160028	1	Cam ONLY for 1/4 Turn Lock
3	875061	1	1/4 Turn Lock with Key and Cam
	160105*	1	1/4 Turn Mer-Pel Key ONLY
4	802020	1	1/4 Turn Coin Box Assembly (includes illus. nos. 2 through 5)
	802019	1	1/4 Turn Coin Box ONLY without Faceplate
	125915	1	High Security (Greenwald) Coin Box ONLY with Key
5	802018	1	1/4 Turn Coin Box Faceplate ONLY
6	152014	4	1/4-20 Free Spin Wash Nut
7	102502	1	Control Door Support Rod
8	102601	1	Control Door Rod Retainer Clip
9	102603	1	Control Door Rod Support Catch

* Specify key number when ordering.

Dual Timer Control Box Assembly

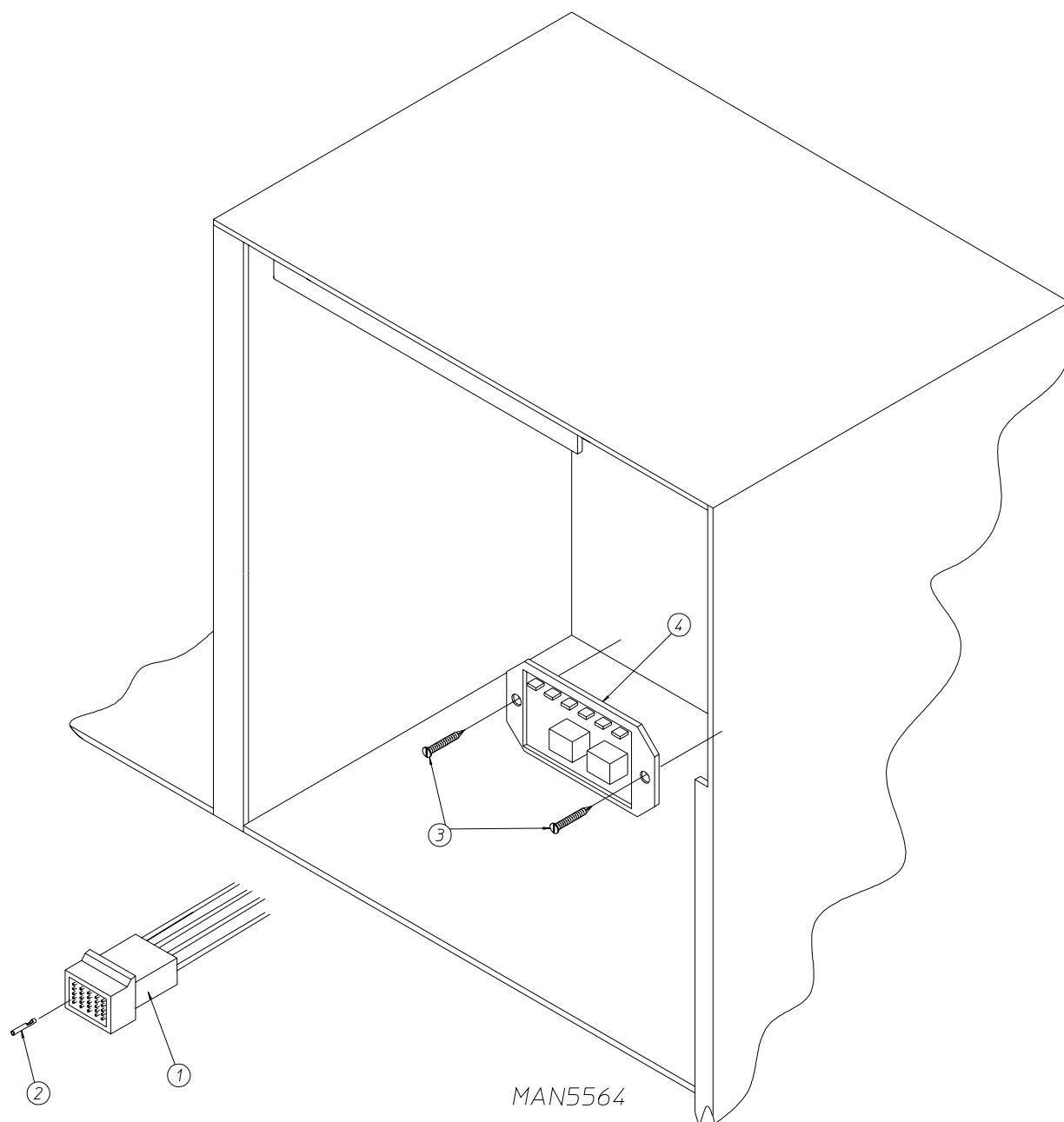

JCARRITA 12/26/00

<u>Illus. No.</u>	<u>Part No.</u>	<u>Qty.</u>	<u>Description</u>
1	122641	1	15-Pin Connector
2	122706	15	Socket Terminal
	122801	1	Pin / Socket Terminal Extraction Tool ... Not Illustrated
3	150301	2	#8-18 x 7/16" Phillips Pan Head TEK Screw
4	884252	1	Reversing Timer 24 Volt (for reversing dual timer models Only)

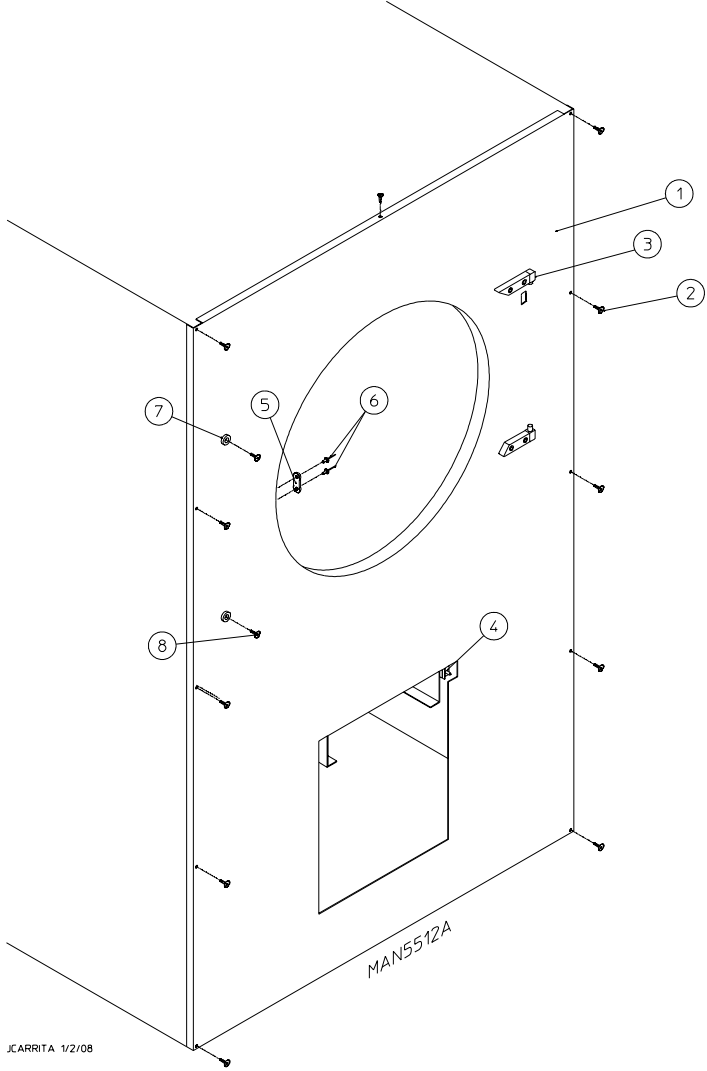

<u>Illus. No.</u>	<u>Part No.</u>	<u>Qty.</u>	<u>Description</u>
1*	801604	1	Front Panel Assembly (for models mfd. as of September 11, 2006) (includes illus. nos. 1, 7, and 8)
	802267	1	Front Panel Assembly (for models mfd. prior to September 11, 2006) (includes illus. nos. 1, 5, and 6)
2	150313	11	#10-16 x 1/2" TORX PLUS®
	150318	1	25 IP TORX PLUS® Bit 1/4 Hex (for removal of TORX® head screw)
3	881152	1	Main Door Hinge Block Assembly (top)
	881151	1	Main Door Hinge Block Assembly (bottom)
4	—	1	Lint Drawer Switch (refer to Lint Drawer / Lint Drawer Switch Assembly on page 19)
5	881987	1	Friction Door Latch Kit (includes illus. nos. 5 and 6)
6	154215	2	5/32" Pop Rivet
7	102004	2	0.750 Round Door Magnet
8	152223	2	1/2" TORX® Head Screw

* Specify color when ordering.

37-1/4" Main Door Assembly

For Models Mfd. as of September 11, 2006

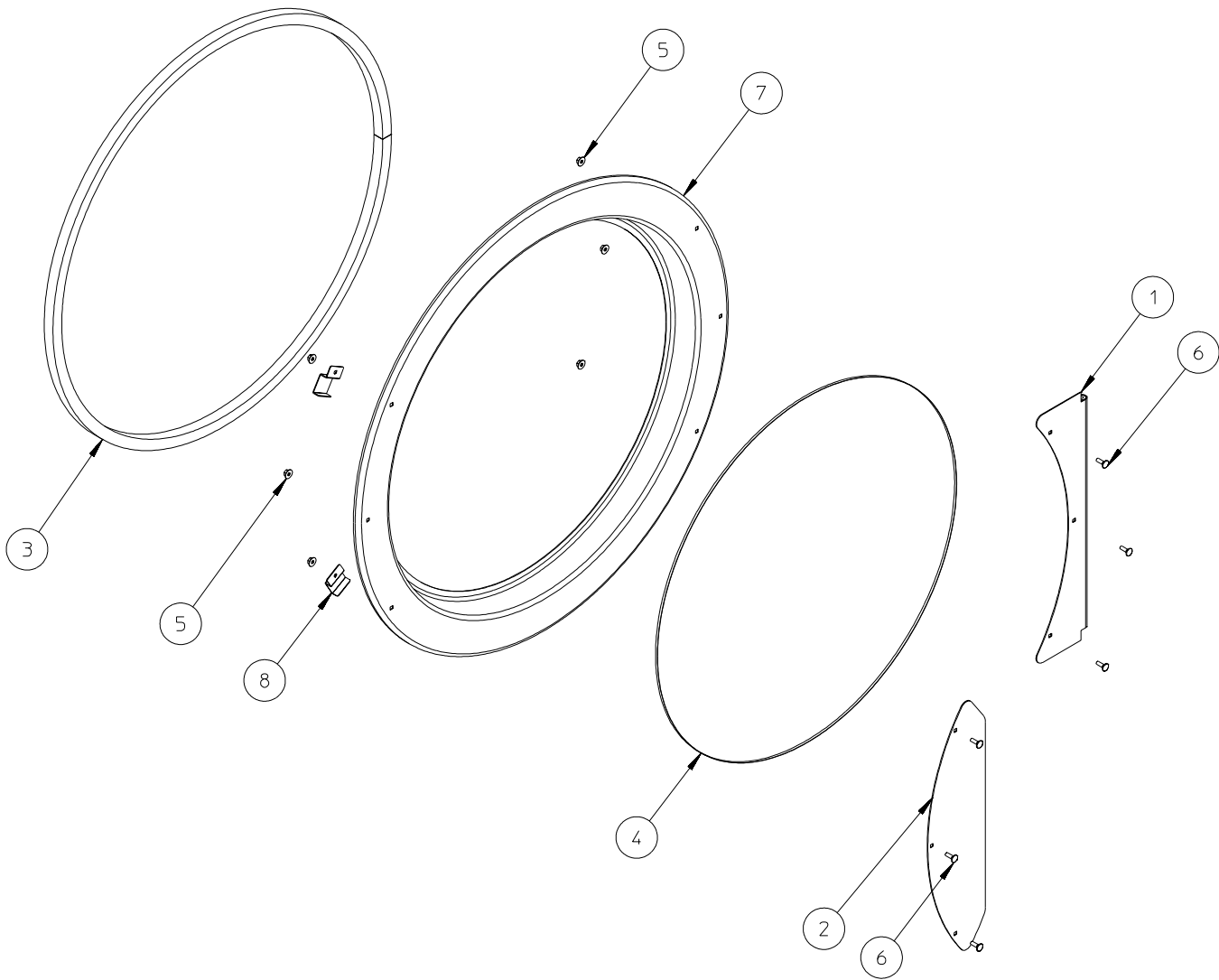

JCARRITA 1/2/08

MAN7532

<u>Illus. No.</u>	<u>Part No.</u>	<u>Qty.</u>	<u>Description</u>
1	835128	1	Main Door Hinge
2	314729	1	Main Door Handle
3	102357	1	Door Gasket
	170731	1	Black Adhesive (10.3 oz. cartridge)
4	102221	1	Door Glass
	170731	1	Black Adhesive (10.3 oz. cartridge)
5	152014	6	1/4-20 Free Spin Wash Nut
6	150683	6	1/4-20 x 5/8" Carriage Bolt
7	801600	1	Main Door Assembly Complete
8	185522	2	Main Door Magnet Bracket

25-1/2" Main Door Assembly

For Models Mfd. prior to September 11, 2006

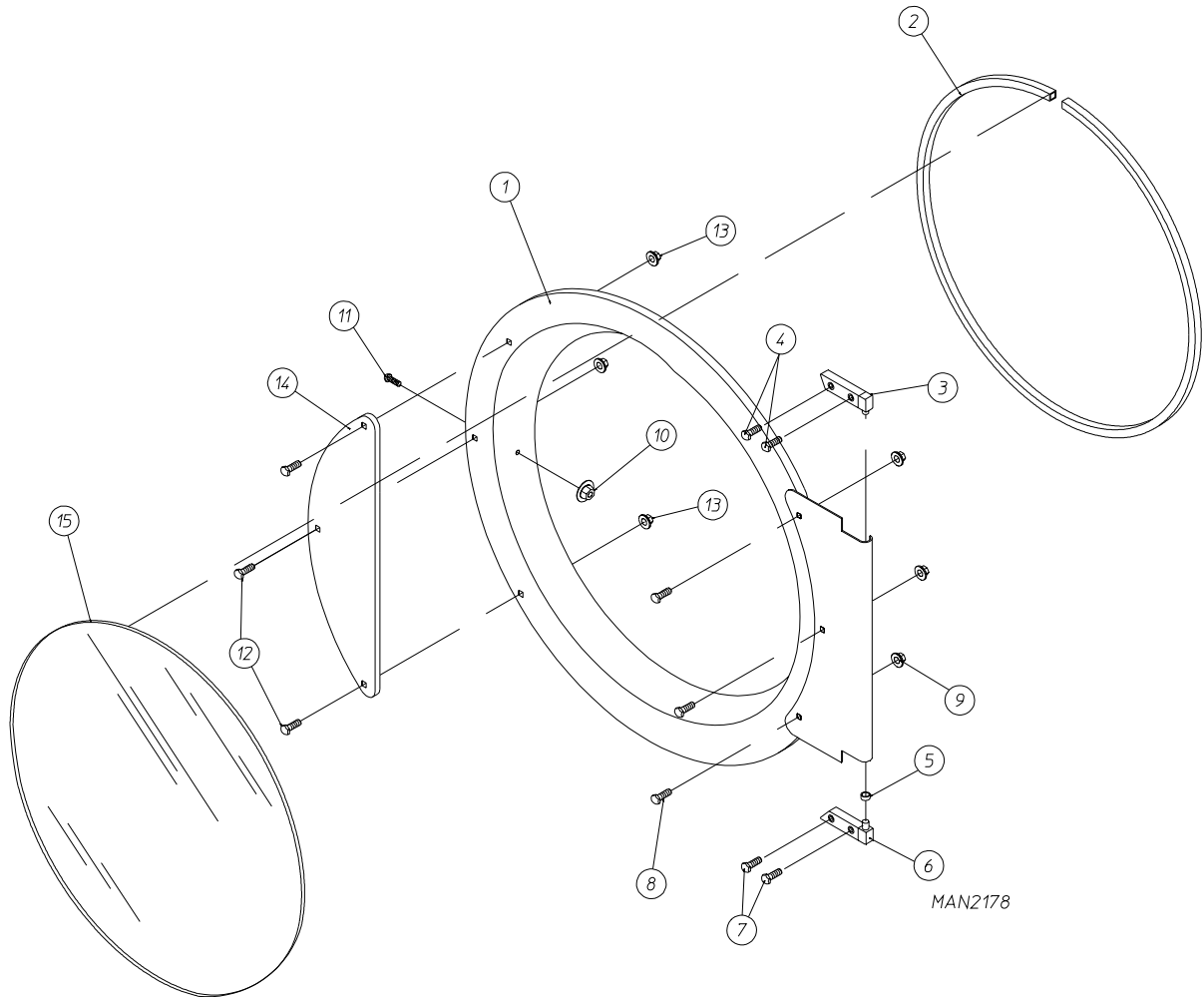

MAN2178

<u>Illus. No.</u>	<u>Part No.</u>	<u>Qty.</u>	<u>Description</u>
1	881150	1	Black Main Door Assembly Complete (includes illus. nos. 1, 2, and 8 through 15)
2	102354	1	Door Gasket
	170731	1	Black Gasket Adhesive (10.3 oz. cartridge)
3	881152	1	Black Top Hinge Block Assembly (includes illus. nos. 3 and 4)
4	150445	2	1/4-20 x 3/4" Black Cap Head Setscrew
5	153031	1	1/4" Nylon Washer
6	881151	1	Black Bottom Hinge Block Assembly (includes illus. nos. 5 through 7)
7	150445	2	1/4-20 x 3/4" Black Cap Head Setscrew
8	150683	3	1/4-20 x 5/8" Black Carriage Bolt
9	152014	3	1/4-20 Free Spin Wash Nut
10	151010	1	#10-32 Black Hex Acorn Nut
11	150120	1	Door Latch Screw
12	150683	3	1/4-20 x 5/8" Black Carriage Bolt
13	152014	3	1/4-20 Free Spin Wash Nut
14	881210	1	Black Main Door Handle ONLY
15	102211	1	20-7/16" Door Glass
	170731	1	Black Glass Adhesive (10.3 oz. cartridge)

Main Door Switch Assembly

For Models Mfd. as of September 11, 2006

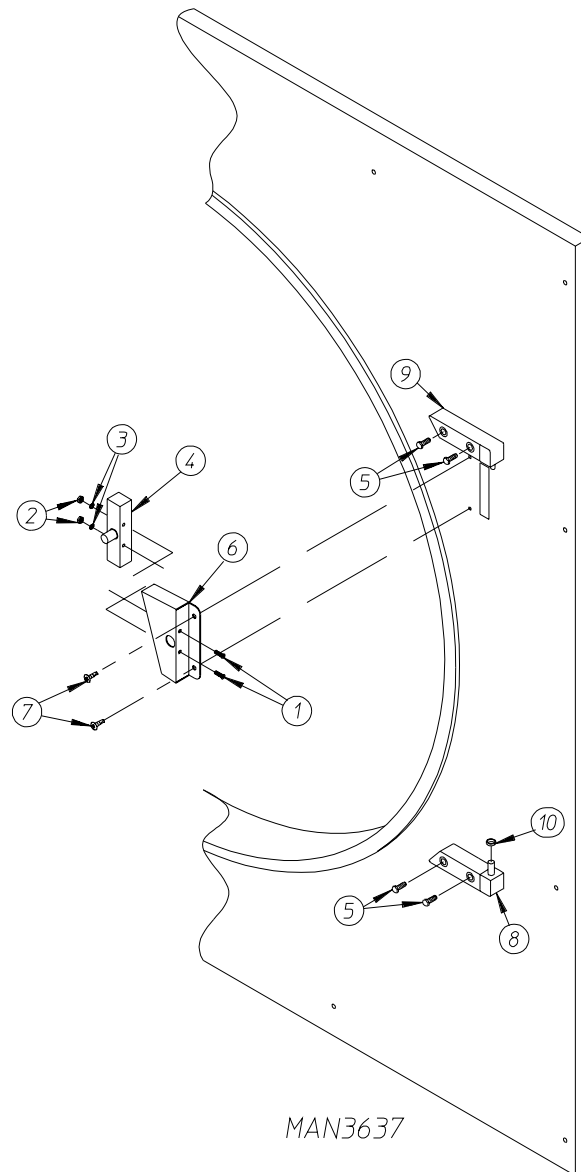

Illus. No.	Part No.	Qty.	Description
1	150006	2	#6-32 x 7/8" Phillips Pan Head Machine Screw
2	152013	2	#6-32 Hex Nut
3	153010	2	#6 Star Washer
4	137005	1	Single-Pole Door Switch
5	150445	4	1/4-20 x 3/4" Cap Screw
6	882866	1	Black Main Door Switch Housing
	883338	1	Black Main Door Switch with Housing Assembly (includes illus. nos. 1 through 4 and 6)
7	150301	2	#8-18 x 7/16" Phillips Pan Head TEK Screw
8	881151	1	Bottom Hinge Block (includes illus. nos. 5, 8, and 10)
9	881152	1	Top Hinge Block (includes illus. nos. 5 and 9)
10	153031	1	Nylon Washer

Main Door Switch Assembly

For Models Mfd. prior to September 11, 2006

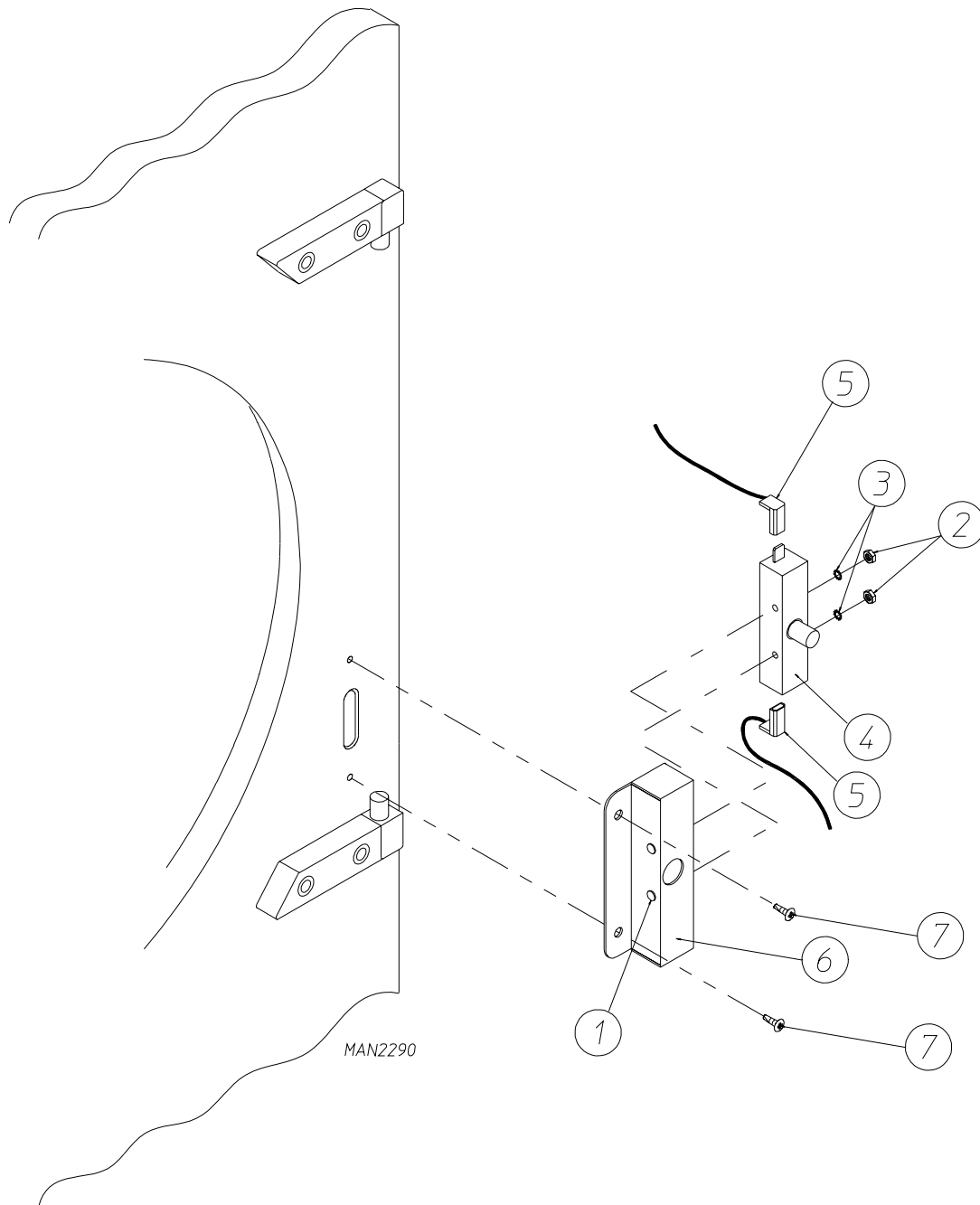

Illus. No.	Part No.	Qty.	Description
1	150006	2	#6-32 x 7/8" Phillips Pan Head Machine Screw
2	152013	2	#6-32 Hex Nut
3	153010	2	#6 Star Washer
4	137005	1	Door Switch
5	122636	2	Flag Terminal
6	881211	1	Black Main Door Switch Housing ONLY
	881153	1	Black Main Door Switch Housing Complete (includes illus. nos. 1 through 4 and 6)
7	150301	2	#8-18 x 7/16" Phillips Pan Head TEK Screw

Tumbler / Support Assemblies

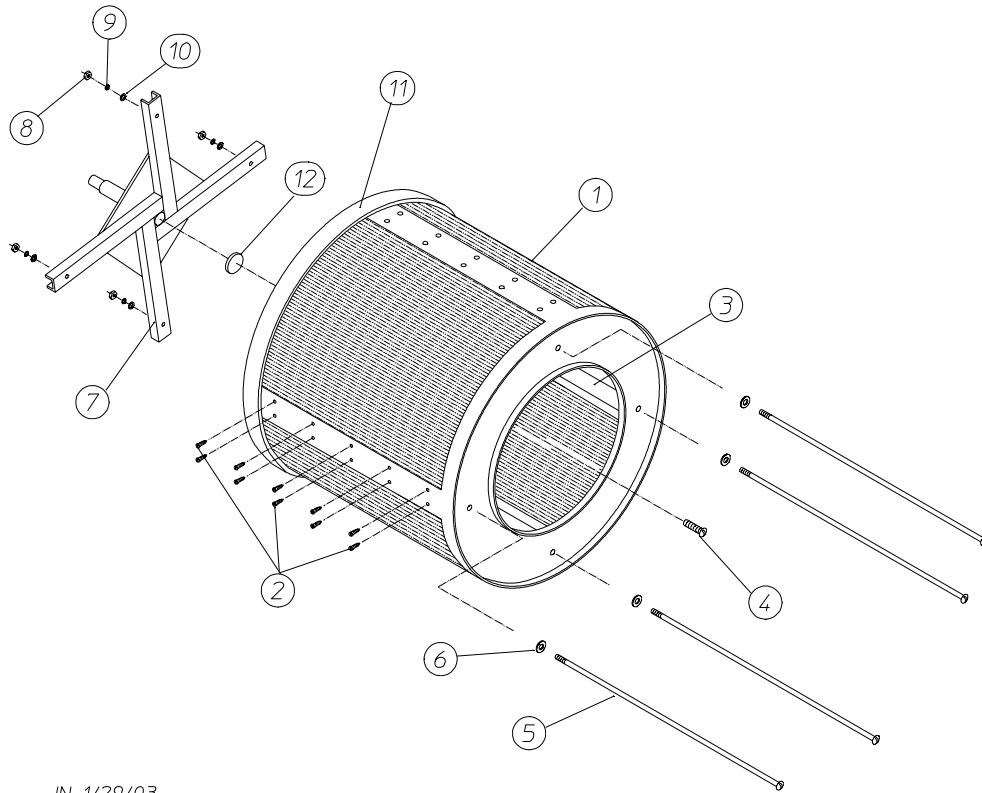

JN 1/29/03

MAN6526

Illus. No.	Part No.	Qty.	Description
1*	859032	1	Tumbler ONLY without Felt Collar (for models mfd. as of September 11, 2006)
	800708	1	Tumbler ONLY without Felt Collar (for models mfd. prior to September 11, 2006)
	859305	1	Tumbler and Support Assembly Complete (for models mfd. as of September 11, 2006)
	800816	1	Tumbler and Support Assembly Complete (for models mfd. prior to September 11, 2006) (includes illus. nos. 1 through 10)
2	150313	40	#10-16 x 1/2" TORX PLUS® Crimptite Screw
	150429	1	TORX® Hand Driver (for removal of TORX® head screw)
3	390074	4	Tumbler Rib ONLY (for models mfd. as of September 11, 2006)
	301308	4	Tumbler Rib ONLY (for models mfd. prior to September 11, 2006)
4	150518	1	5/16-18 x 3/8" Socket Button Head Screw
5	100905	4	3/8-16 x 37" Tie Rod
6	153004	4	3/8" Flat Washer
7	800613	1	Tumbler Support ONLY
8	152005	4	3/8-16 Hex Nut
9	153005	4	3/8" Lock Washer
10	153004	4	3/8" Flat Washer
11	116000	1	Felt Collar ONLY
—	401010	1	#847 Adhesive for Felt Collar
12	115986	1	Felt Pad

* Felt collar is not included and must be ordered separately.

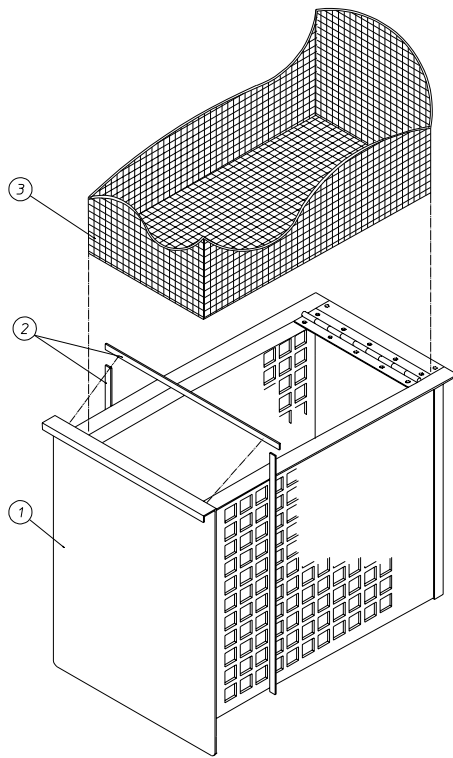

LINT DRAWER

MAN6473

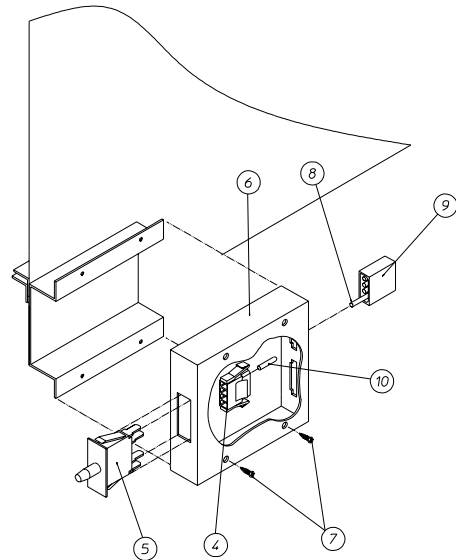

LINT DRAWER SWITCH ASSY

JCARRITA V20703

<u>Illus. No.</u>	<u>Part No.</u>	<u>Qty.</u>	<u>Description</u>
1	884055	1	White Lint Drawer Assembly (includes illus. nos. 1 and 2)
	884056	1	Coral Blue Lint Drawer Assembly (includes illus. nos. 1 and 2)
	884057	1	Ivory Lint Drawer Assembly (includes illus. nos. 1 and 2)
	884149		White Lock Lint Drawer with Bag
	884150		Blue Lock Lint Drawer with Bag
	884151		Ivory Lock Lint Drawer with Bag
	160001	1	AD100 Lock with 1 Key / Hardware ... Not Illustrated
	160052	1	1" Cam with 3/16" Offset ... Not Illustrated
	160103		Key ONLY ... Not Illustrated
2	117605	5	Neoprene Sponge Tape (sold by the foot)
3	108222	1	Lint Screen Assembly
4	122605	*	4-Pin Connector (female)
5	122116	1	Lint Drawer Switch
6	833123	1	Lint Drawer Switch Box Assembly (for micro models Only) (includes illus. nos. 4 through 6 and 10)
	818087	1	Lint Drawer Switch Box Assembly (for dual timer models Only) (includes illus. nos. 4 through 6 and 10)
	304136	1	Lint Drawer Switch Box Cover ONLY
7	150301	2	#8-18 x 7/16" Phillips Pan Head TEK Screw
8	122700	*	Pin Terminal ONLY
9	122604	*	4-Pin Connector (male)
10	122701	*	Socket Terminal ONLY
	122801	1	Pin / Socket Extraction Tool ... Not Illustrated

* As needed.

Idler Bearing Assembly

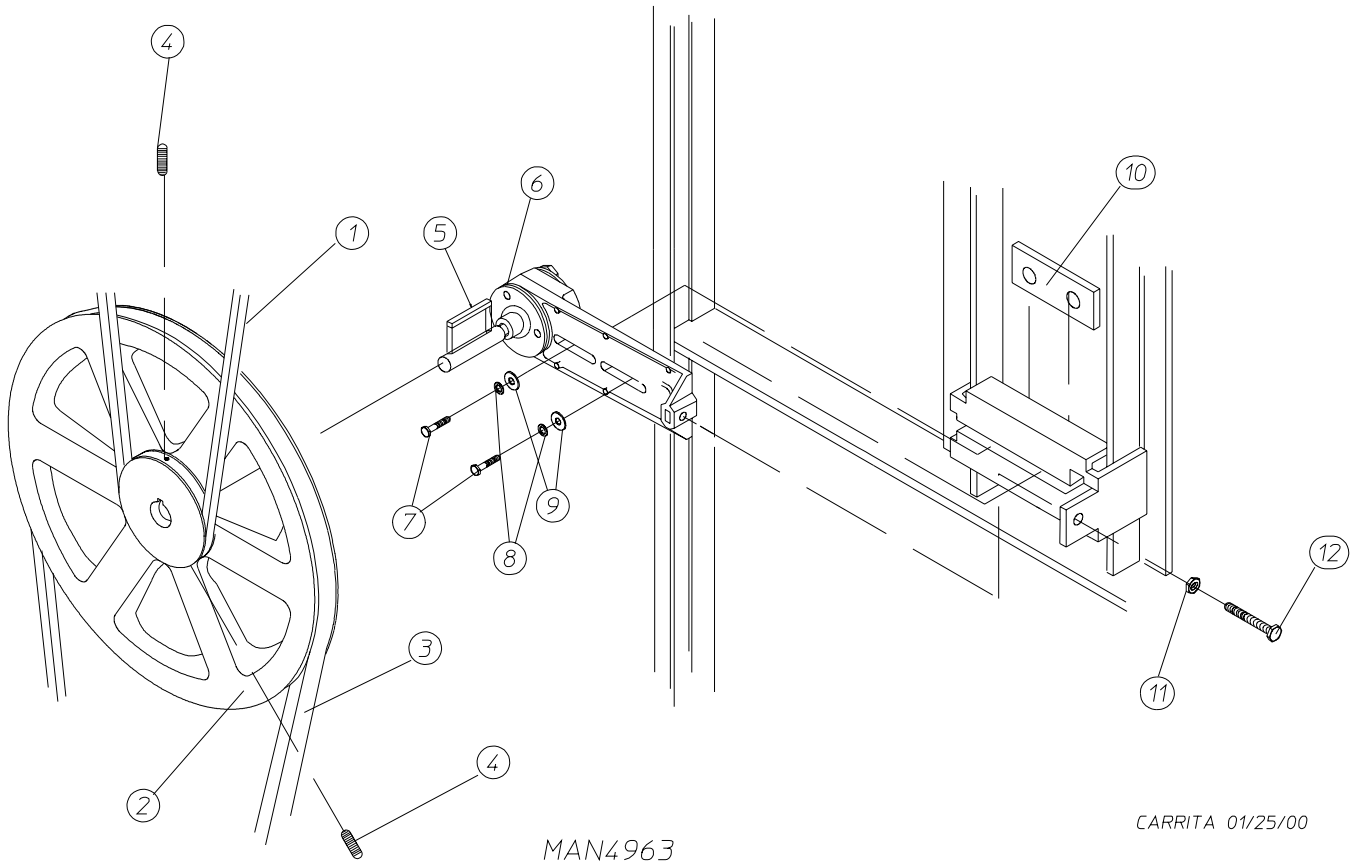

Illus. No.	Part No.	Qty.	Description
1	100108	1	5L-680 V-Belt (tumbler to idler)
2	101140	1	14" x 3" Compound Pulley
3	100194	1	4L-720 V-Belt (idler to motor) for Non-Reversing Models ONLY
	100109	1	4L-650 V-Belt (idler to motor) for Reversing Models ONLY
4	154301	2	5/16-18 x 1" Allen Setscrew
5	100705	1	3/16" x 3/16" x 1-3/8" Key
6	882576	1	Idler Bearing Assembly Complete (includes illus. nos. 5 through 12)
7	150617	2	3/8-16 x 1" Hex Head Machine Bolt
8	153005	2	3/8" Lock Washer
9	153004	2	3/8" Flat Washer
10	801009	1	Idler Square Washer
11	152004	1	5/16-18 Hex Nut
12	150509	1	5/16-18 x 3" Hex Head Machine Bolt

Tumbler Bearing Assembly

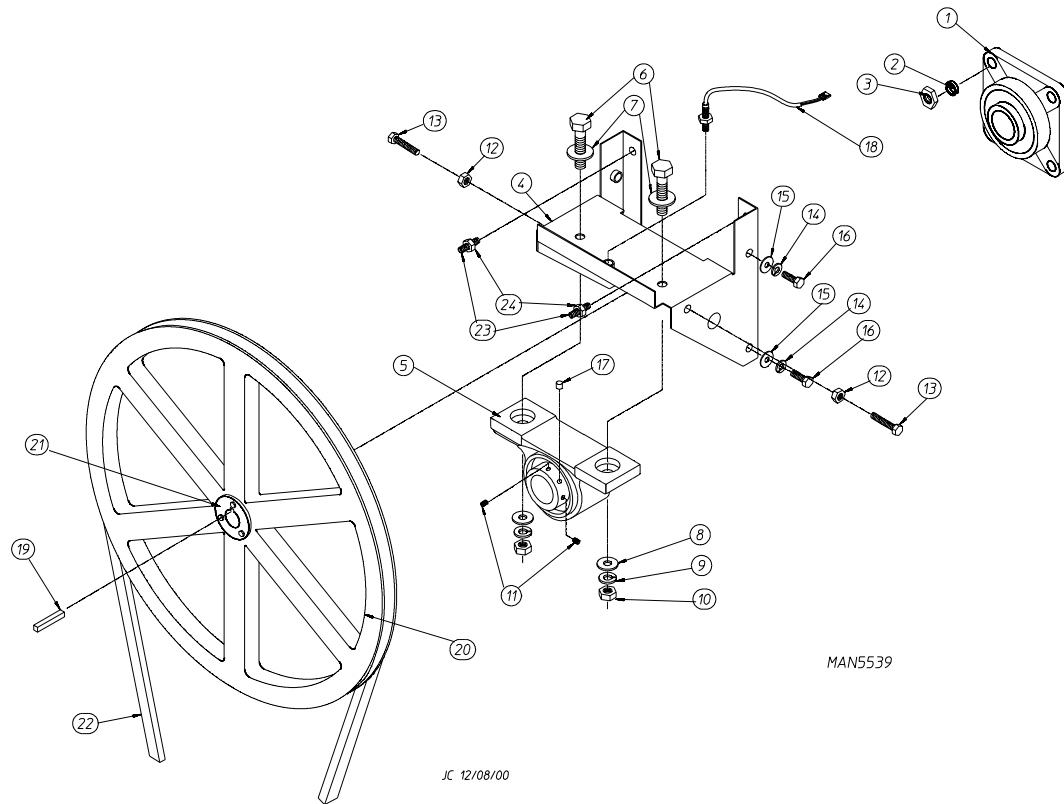

MAN5539

JC 12/08/00

<u>Illus. No.</u>	<u>Part No.</u>	<u>Qty.</u>	<u>Description</u>
1	880220	1	1-3/4" Flange Bearing
2	153025	4	9/16" Lock Washer
3	152050	4	9/16-12 Hex Nut
4	883387	1	Pillow Block Bearing Assembly Complete (includes illus. nos. 4 through 18, 23 and 24)
	882543	1	Pillow Block Bearing Platform ONLY
5	880779	1	1-3/8" Pillow Block Bearing
6	150601	2	3/8-16 x 2" Hex Bolt
7	153004	2	3/8" Flat Washer
8	153004	2	3/8" Flat Washer
9	153005	2	3/8" Lock Washer
10	152005	2	3/8-16 Hex Nut
11	154326	2	5/16-24 x 3/8" Setscrew
12	152004	2	5/16-18 Hex Nut
13	150621	2	5/16-18 x 1-1/2" Tap Bolt
14	153002	4	5/16" Lock Washer
15	153004	6	3/8" Flat Washer
16	150501	4	5/16-18 x 3/4" Tap Bolt
17	102120	1	Sintered 8 Magnet
18	883386	1	Rotational Sensor Assembly
19	100735	1	Shaft Key (for reversing models Only)
	100724	1	Shaft Key (for non-reversing models Only)
20	884042	1	18" Pulley (for non-reversing models Only)
	101118	1	18-3/4" Pulley (for reversing models Only)
21	101110	1	1" Taper Lock Bushing (for reversing models Only)
22	100108	1	5L-680 V-Belt (tumbler to idler)
23	150610	2	5/16-18 x 1-1/2 Allen Setscrew
24	152004	2	5/16-18 Hex Nut

Non-Reversing Motor Mount Assembly

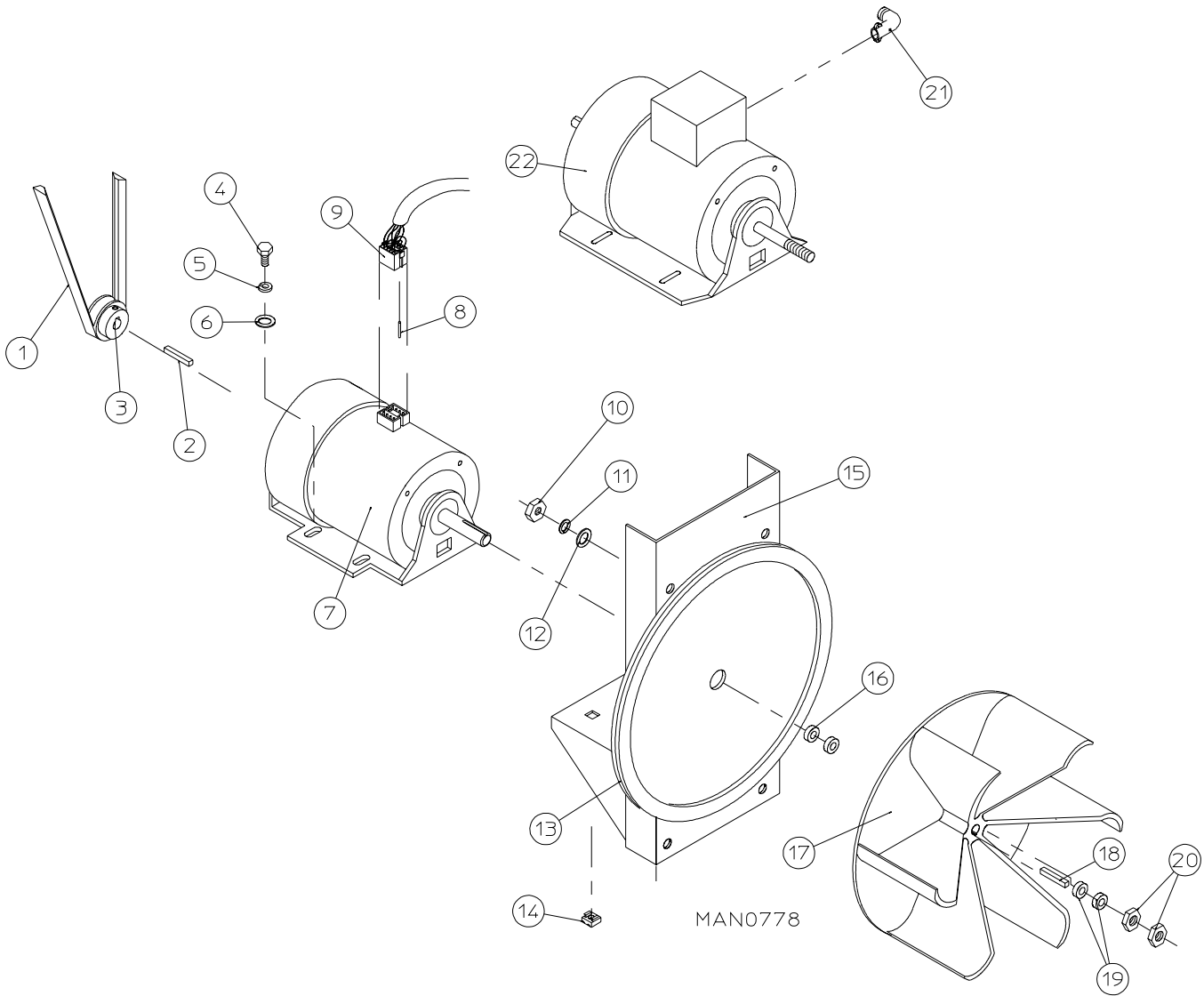

Illus. No.	Part No.	Qty.	Description
1	100194	1	4L-720 V-Belt (idler to motor)
2	100701	1	3/16" x 3/16" x 1" Key
3	101130	1	5/8" x 2-1/2" Motor Pulley (60 Hz Only) (for models mfd. as of September 11, 2006)
	101139	1	5/8" x 2-3/4" Motor Pulley (50 Hz Only) (for models mfd. as of September 11, 2006)
	101133	1	5/8" x 2-1/4" Motor Pulley (60 Hz Only) (for models mfd. prior to September 11, 2006)
	101130	1	5/8" x 2-1/2" Motor Pulley (50 Hz Only) (for models mfd. prior to September 11, 2006)
4	150501	4	5/16-18 x 3/4" Tap Bolt
5	153002	4	5/16" Lock Washer

Non-Reversing Motor Mount Assembly

<u>Illus. No.</u>	<u>Part No.</u>	<u>Qty.</u>	<u>Description</u>
6	153001	4	5/16" Flat Washer
7	100073	1	1 hp 120/208/230v (1Ø) 60 Hz Motor with Plug (56Z frame)
	181050	1	1 hp 200-240v (1Ø) 50 Hz Motor with Plug
8	122701	8	Socket Terminal ONLY
	122801	1	Pin / Socket Extraction Tool ... Not Illustrated
9	137030	1	8-Pin Housing Connector
10	152004	4	5/16-18 Hex Nut
11	153002	4	5/16" Lock Washer
12	153001	4	5/16" Flat Washer
13	117604	4	Noise Suppression Tape (sold by the foot)
14	154000	4	5/16-18 Tinnerman Nut
15	803561	1	Non-Reversing Motor Mount ONLY (56Z frame)
	803876	1	1 hp 120/230v (1Ø) 60 Hz Motor Mount Assembly with Plug Complete (for models mfd. as of September 11, 2006) (includes illus. nos. 2 through 7 and 13 through 20)
	823212	1	1 hp 200-240v (1Ø) 50 Hz Non-Reversing Motor Mount Assembly Complete (for models mfd. as of September 11, 2006) (includes illus. nos. 2 through 7 and 13 through 20)
	803877*	1	1 hp 200-460v (3Ø) 60 Hz Non-Reversing Motor Mount Assembly Complete (for models mfd. as of September 11, 2006) (includes illus. nos. 2 through 6 and 13 through 22)
	803879*	1	1 hp 200-416v (3Ø) 50 Hz Non-Reversing Motor Mount Assembly Complete (for models mfd. as of September 11, 2006) (includes illus. nos. 2 through 6 and 13 through 22)
	803945*	1	1 hp 120/230v (1Ø) 60 Hz Motor Mount Assembly with Plug Complete (for models mfd. prior to September 11, 2006) (includes illus. nos. 2 through 7 and 13 through 20)
	801824	1	1 hp 200-240v (1Ø) 50 Hz Non-Reversing Motor Mount Assembly Complete (for models mfd. prior to September 11, 2006) (includes illus. nos. 2 through 7 and 13 through 20)
	803955*	1	1 hp 200-460v (3Ø) 60 Hz Non-Reversing Motor Mount Assembly Complete (for models mfd. prior to September 11, 2006) (includes illus. nos. 2 through 6 and 13 through 22)
	803958*	1	1 hp 200-416v (3Ø) 50 Hz Non-Reversing Motor Mount Assembly Complete (for models mfd. prior to September 11, 2006) (includes illus. nos. 2 through 6 and 13 through 22)
16	153051	1	3/4" Flat Washer
17	882670	1	16" Impellor with 3/4" Bore
18	100714	1	3/16" x 3/16" x 1-7/8" Key
19	153050	2	1/2" Flat Washer
20	152006	2	1/2-20 Left Hand Jam Nut
21	120200	1	3/8" x 90° Connector
22	100075*	1	1 hp 208/230/460v (3Ø) 50/60 Hz Motor

* Specify voltage when ordering.

Reversing Motor Mount Assembly

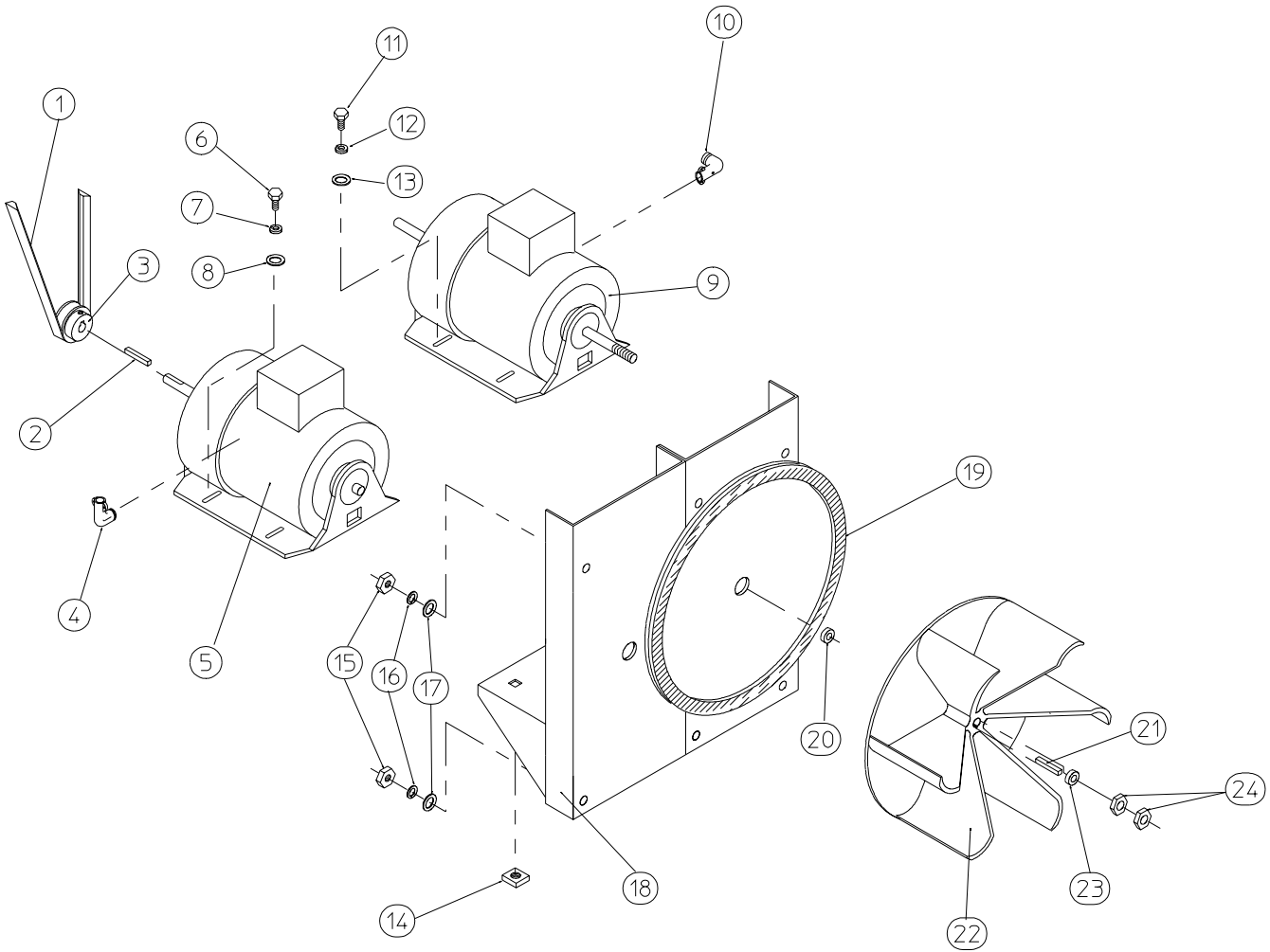

MAN0250

<u>Illus. No.</u>	<u>Part No.</u>	<u>Qty.</u>	<u>Description</u>
1	100109	1	4L-650 V-Belt (to idler assembly)
2	100701	1	3/16" x 3/16" x 1" Key
3	101130	1	5/8" x 2-1/2" Motor Pulley (60 Hz Only) (for models mfd. as of September 11, 2006)
	101139	1	5/8" x 2-3/4" Motor Pulley (50 Hz Only) (for models mfd. as of September 11, 2006)
	101133	1	5/8" x 2-1/4" Motor Pulley (60 Hz Only) (for models mfd. prior to September 11, 2006)
	101130	1	5/8" x 2-1/2" Motor Pulley (50 Hz Only) (for models mfd. prior to September 11, 2006)
4	120200	1	3/8" x 90° Connector
5	181003	1	1/2 hp 208/230/380/460v (3ø) 50/60 Hz Motor (56Z frame)
6	150501	4	5/16-18 x 3/4" Tap Bolt
7	153002	4	5/16" Lock Washer
8	153001	4	5/16" Flat Washer
9	100075	1	1 hp 200/230/460v (3ø) 60 Hz 380v-415v (3ø) 50 Hz Motor with 3/4" Shaft (56Z frame)
10	120200	1	3/8" x 90° Connector
11	150501	4	5/16-18 x 3/4" Tap Bolt
12	153002	4	5/16" Lock Washer
13	153001	4	5/16" Flat Washer
14	154000	8	5/16-18 Tinnerman Nut
15	152004	6	5/16-18 Hex Nut
16	153002	6	5/16" Lock Washer
17	153001	6	5/16" Flat Washer
18	803566	1	Reversing Motor Mount ONLY (56Z frame)
	803882*	1	60 Hz Reversing Motor Mount ONLY (56Z frame) (for models mfd. as of September 11, 2006) (includes illus. nos. 2 through 14 and 18 through 24)
	803879*	1	50 Hz Reversing Motor Mount ONLY (56Z frame) (for models mfd. as of September 11, 2006) (includes illus. nos. 2 through 14 and 18 through 24)
	804029*	1	60 Hz Reversing Motor Mount Assembly Complete (includes illus. nos. 2 through 14 and 18 through 24)
	804030*	1	50 Hz Reversing Motor Mount Assembly Complete (includes illus. nos. 2 through 14 and 18 through 24)
19	117604	5	Noise Suppression Tape (sold by the foot)
20	153051	1	3/4" Flat Washer
21	100714	1	3/16" x 3/16" x 1-7/8" Key
22	882670	1	16" Impellor with 3/4" Bore
23	153050	**	1/2" Flat Washer
24	152006	2	1/2-20 Left Hand Jam Nut

* Specify voltage when ordering.

** As required.

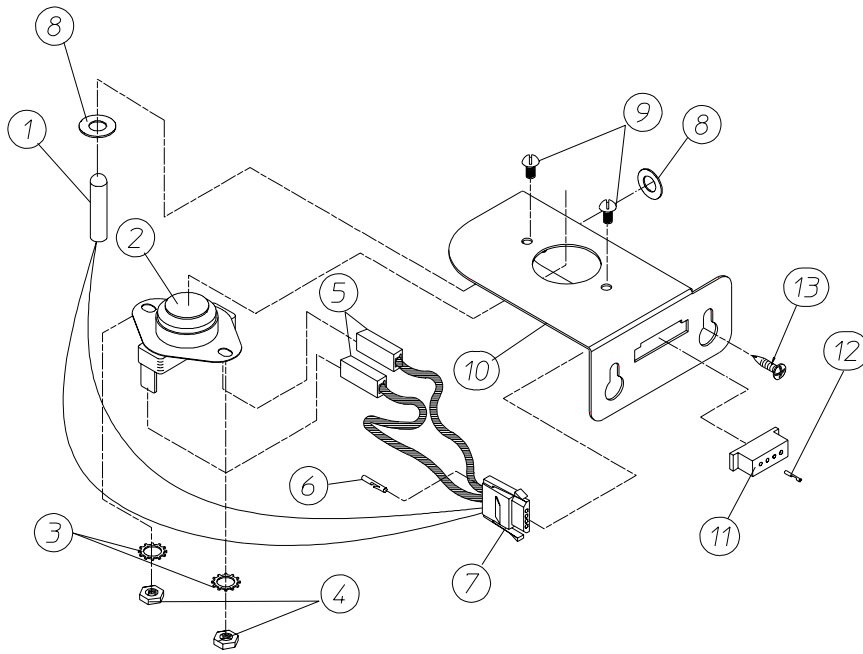

MICROPROCESSOR SENSOR BRACKET ASSEMBLY

MAN6453

JNERY 1/23/03

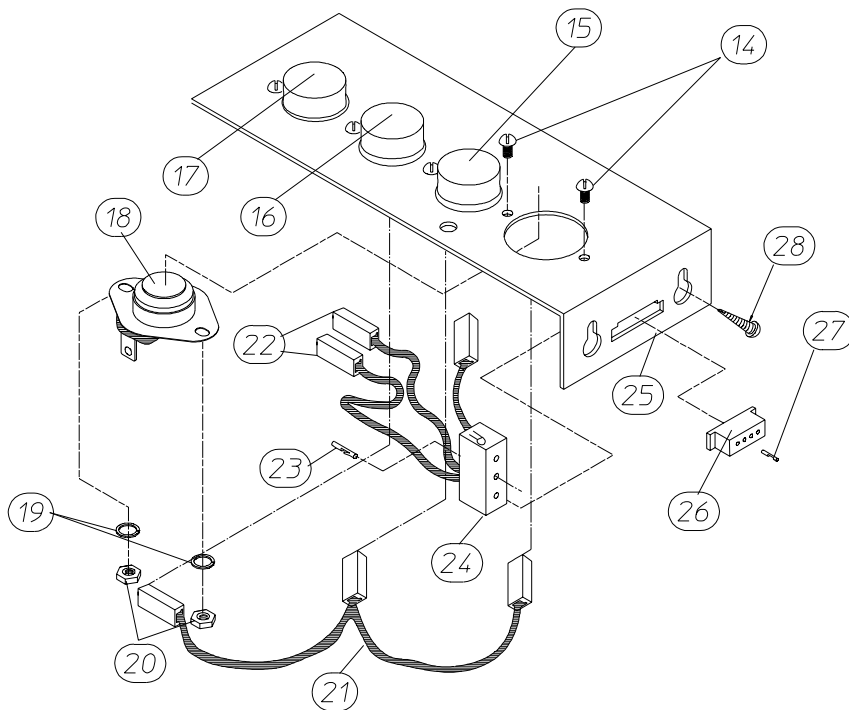

NON-COMPUTER SENSOR BRACKET ASSEMBLY

<u>Illus. No.</u>	<u>Part No.</u>	<u>Qty.</u>	<u>Description</u>
1	880251	1	1/4" Temperature Sensor Probe Assembly (includes illus. nos. 1 and 5 through 8)
2	130103	1	225° Automatic Reset Thermostat
3	153010	2	#6 Star Washer
4	152000	2	#6-32 Hex Nut
5	121028	2	Insulated Female Terminal
6	122701	4	Socket Terminal ONLY
	122801	1	Pin / Socket Extraction Tool ... Not Illustrated
7	122605	1	4-Pin Connector (female)
8	154007	2	1/4" Tinnerman Push On Fastener
9	150005	2	#6-32 x 1/4" Phillips Round Head Machine Screw
10	817046	1	Microprocessor Sensor Bracket Assembly Complete (includes illus. nos. 1 through 10)
	322214	1	Microprocessor Sensor Bracket ONLY
11	122604	1	4-Pin Connector (male)
12	122700	4	Pin Terminal ONLY
13	150301	2	#8-18 x 7/16" Phillips Pan Head TEK Screw
14	150005	5	#6-32 x 1/4" Phillips Round Head Machine Screw
15	130111	1	130° Large Thermostat
16	130100	1	150° Large Thermostat
17	130103	1	225° Automatic Reset Thermostat
18	130101	1	180° Large Thermostat
19	153010	5	#6 Star Washer
20	152000	5	#6-32 Hex Nut
21	882535	1	Sensor Jumper ONLY
22	121028	4	Insulated Female Terminal
23	122701	4	Socket Terminal ONLY
24	122605	1	4-Pin Connector (female)
	882534	1	Sensor Bracket Harness Assembly (includes illus. nos. 22 through 24)
25	882536	1	Noncomputer Sensor Bracket Assembly Complete (includes thermostats) (includes illus. nos. 14 through 25)
	322062	1	Universal Sensor Bracket ONLY
26	122604	1	4-Pin Connector (male)
27	122700	4	Pin Terminal ONLY
	122801	1	Pin / Socket Extraction Tool ... Not Illustrated
28	150301	2	#8-18 x 7/16" Phillips Pan Head TEK Screw

Direct Spark Ignition Burner Assembly

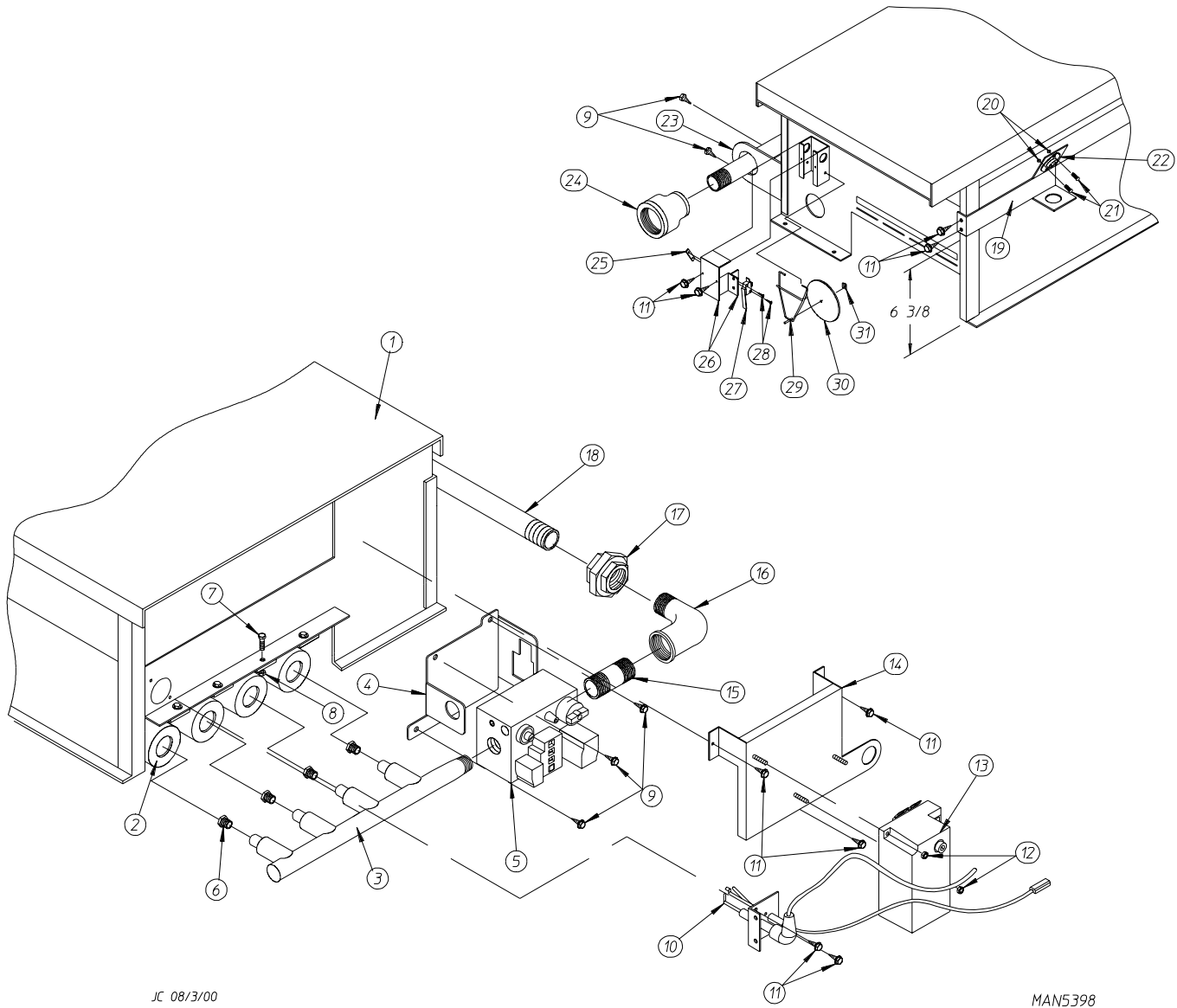

JC 08/3/00

MAN5398

Direct Spark Ignition Burner Assembly

<u>Illus. No.</u>	<u>Part No.</u>	<u>Qty.</u>	<u>Description</u>
1*	817086	1	ADG-75V / ADG-758DV Natural Gas Burner Assembly Complete (includes illus. nos. 1 through 31)
	817137	1	ADG-75V / ADG-758DV Liquid Propane Gas Burner Assembly Complete (includes illus. nos. 1 through 31)
	810047	1	Burner Box ONLY
2	141105	4	Large Burner Tube
3	141210	1	3/4" Direct Spark Ignition Manifold (4-port)
4	318714	1	Bracket for Horizontal Facing Gas Valve
5	128927	1	1/2" 24 VAC Redundant (natural gas) Gas Valve
	880960	1	1/2" 24 VAC Direct Spark Ignition Liquid Propane Gas Valve Assembly
	882575**	1	ADG-75V Liquid Propane Conversion Kit
	883299**	1	ADG-758DV Liquid Propane Conversion Kit
6**	140820	4	#29 Burner Orifice (natural gas) ADG-75V ONLY
	140805	4	#47 Burner Orifice (liquid propane gas) ADG-75V ONLY
	140819	4	#30 Burner Orifice (natural gas) ADG-758DV ONLY
	140803	4	#49 Burner Orifice (liquid propane gas) ADG-758DV ONLY
7	150103	4	#8-32 x 3/4" Phillips Round Head Machine Screw
8	151001	4	#8-32 Pal Nut
9	150300	5	#10-16 x 1/2" Hex Washer TEK Screw
10	884265	1	Ignitor Probe Assembly
	884279	1	High Voltage Wire with 1/4" Spade Connection
	883031	1	High Voltage Wire with Socket Connection (for models with spike style connection at module)
11	150309	9	#10-16 x 1/2" Hex Head TEK Crimptite Screw
12	152013	2	#6-32 Hex Nut
13	883849	1	Direct Spark Ignition Module with High Voltage Wire
14	810029	1	Direct Spark Ignition Module Mounting Bracket
15	142707	4	1/2" x 1-1/2" Long Black Nipple
16	142506	1	1/2" Street Elbow
17	142600	1	1/2" Black Union
18	142809	1	1/2" x 29-1/8" Nipple
19	319704	1	Hi-Limit Mounting Bracket
20	151000	2	#6-32 Pal Nut
21	150001	2	#6-32 x 1/2" Phillips Round Head Machine Screw
22	130201	1	330° Hi-Limit Manual Reset
23	318700	1	Pipe Bracket (bent)
24	143000	1	3/4" to 1/2" Reducing Coupling
25	154004	1	Twin Speed Nut
26	802799	1	Sail Switch Box Cover and Bracket ONLY (refer to Sail Switch Assembly on page 34)
27	122200	1	Sail Switch ONLY
28	150303	2	#4 x 3/4" Pan Head "A" Machine Screw
29	105500	1	Sail Switch Actuator Rod
30	319202	1	Sail Switch Damper (flat)
31	154002	1	1/8" Push On Fastener

* Burner orifices are not included and must be ordered separately.

** Consult factory for elevations over 2,000 feet.

Direct Spark Ignition Burner CE Assembly

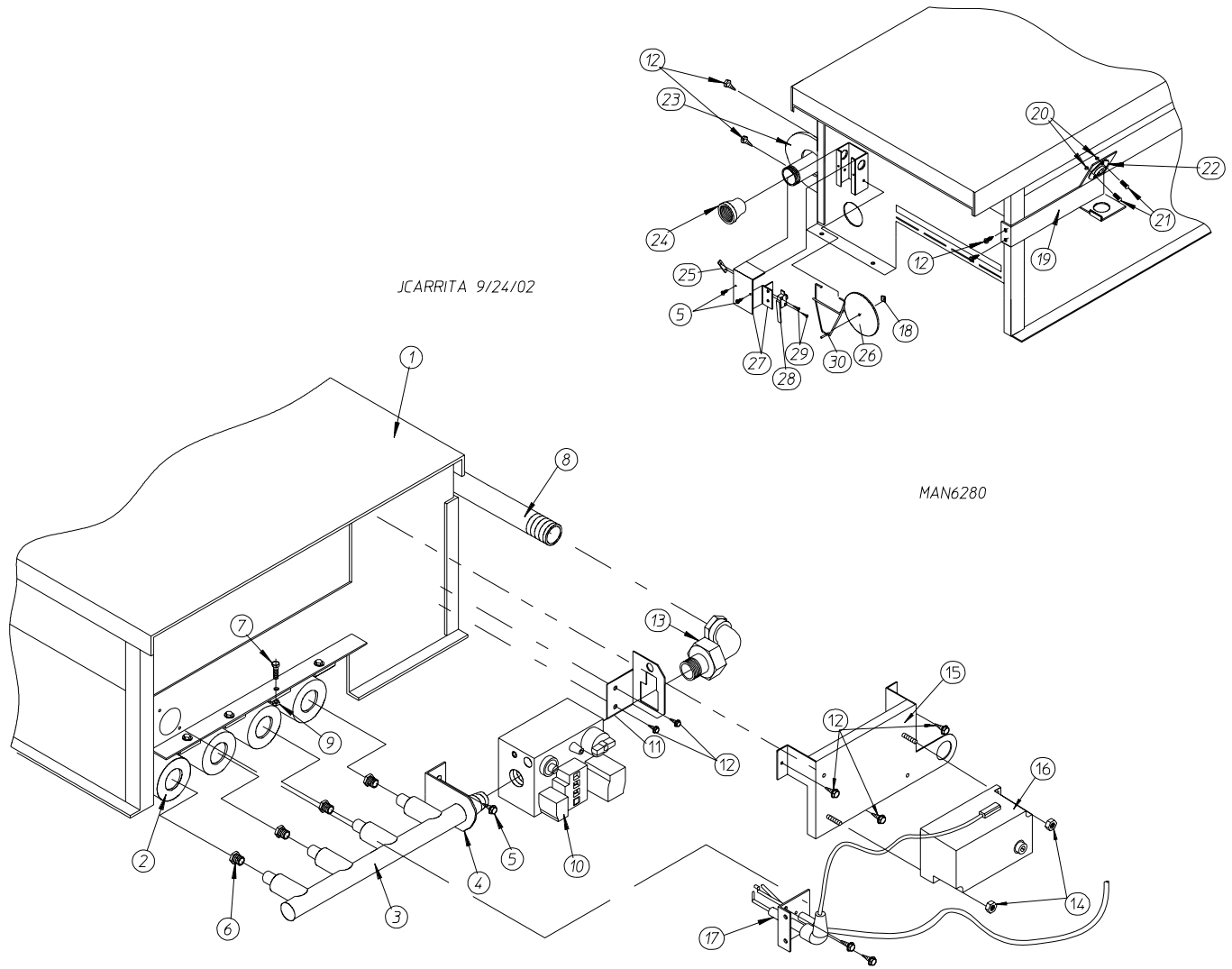

Direct Spark Ignition Burner CE Assembly

<u>Illus. No.</u>	<u>Part No.</u>	<u>Qty.</u>	<u>Description</u>
1	810047	1	Direct Spark Ignition Burner Box ONLY
	809686*	1	Natural Gas Burner Assembly (includes illus. nos. 1 through 5 and 7 through 30)
	817209*	1	Liquid Propane Gas Burner Assembly (includes illus. nos. 1 through 5 and 7 through 30)
2	141105	4	Large Tube Burner
3	141210	1	3/4" Direct Spark Ignition Manifold (4-port)
4	323737	1	Pipe Bracket (bent)
5	150300	2	#10-16 x 1/2" Hex Washer TEK Screw
6**	140820	4	#29 Burner Orifice (natural gas) ADG-75V ONLY
	140805	4	#47 Burner Orifice (liquid propane gas) ADG-75V ONLY
	140819	4	#30 Burner Orifice (natural gas) ADG-758DV ONLY
	140803	4	#49 Burner Orifice (liquid propane gas) ADG-758DV ONLY
7	150108	4	#8-32 x 1/2" Pan Head Machine Screw
8	142809	1	1/2" x 29-1/8" Pipe
9	151001	4	#8-32 Pal Nut
10	128933	1	1/2" 24 VAC CE Gas Valve (natural gas)
	883255	1	1/2" 24 VAC CE Gas Valve (liquid propane gas)
	882575**	1	ADG-75V Liquid Propane Conversion Kit
	883299**	1	ADG-758DV Liquid Propane Conversion Kit
11	318712	1	Gas Valve Bracket
12	150309	12	#10-16 x 1/2" Hex Head TEK Crimptite Screw
13	141317	1	1/2" Bronze Union Elbow
14	152013	2	#6-32 Hex Nut
15	817027	1	Direct Spark Ignition Module Mounting Bracket
16	884293	1	ADC CE Direct Spark Ignition Module (2 Tries)
17	884265	1	Ignitor Probe Assembly
	884279	1	High Voltage Wire with 1/4" Spade Connection
	883031	1	High Voltage Wire with Socket Connection (for models with spike style connection at module)
18	154002	1	1/8" Push On Fastener
19	319704	1	Hi-Limit Mounting Bracket
20	151000	2	#6-32 Pal Nut
21	150001	2	#6-32 x 1/2" Round Head Machine Screw
22	130201	1	330° Hi-Limit Manual Reset
23	318700	1	Pipe Bracket (bent)
24	142936	1	3/4" x 1/2" Coupling
25	154004	1	Twin Speed Nut
26	319202	1	Sail Switch Damper (flat)
27	802799	1	Sail Switch Top and Switch Bracket (refer to Sail Switch Assembly on page 34)
28	122200	1	Sail Switch
29	150303	2	3/4" Pan Head Machine Screw
30	105500	1	Sail Switch Actuator Rod

* Burner orifices are not included and must be ordered separately.

** Consult factory for elevations over 2,000 feet.

Electric Oven Assembly

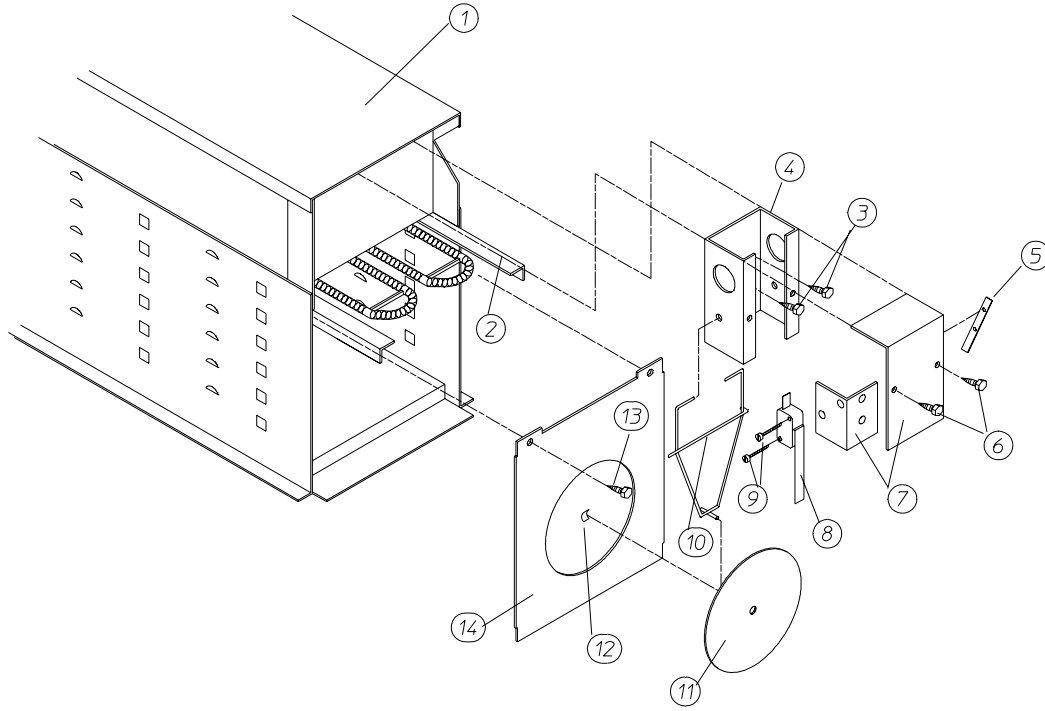

ELECTRIC OVEN (FRONT VIEW)

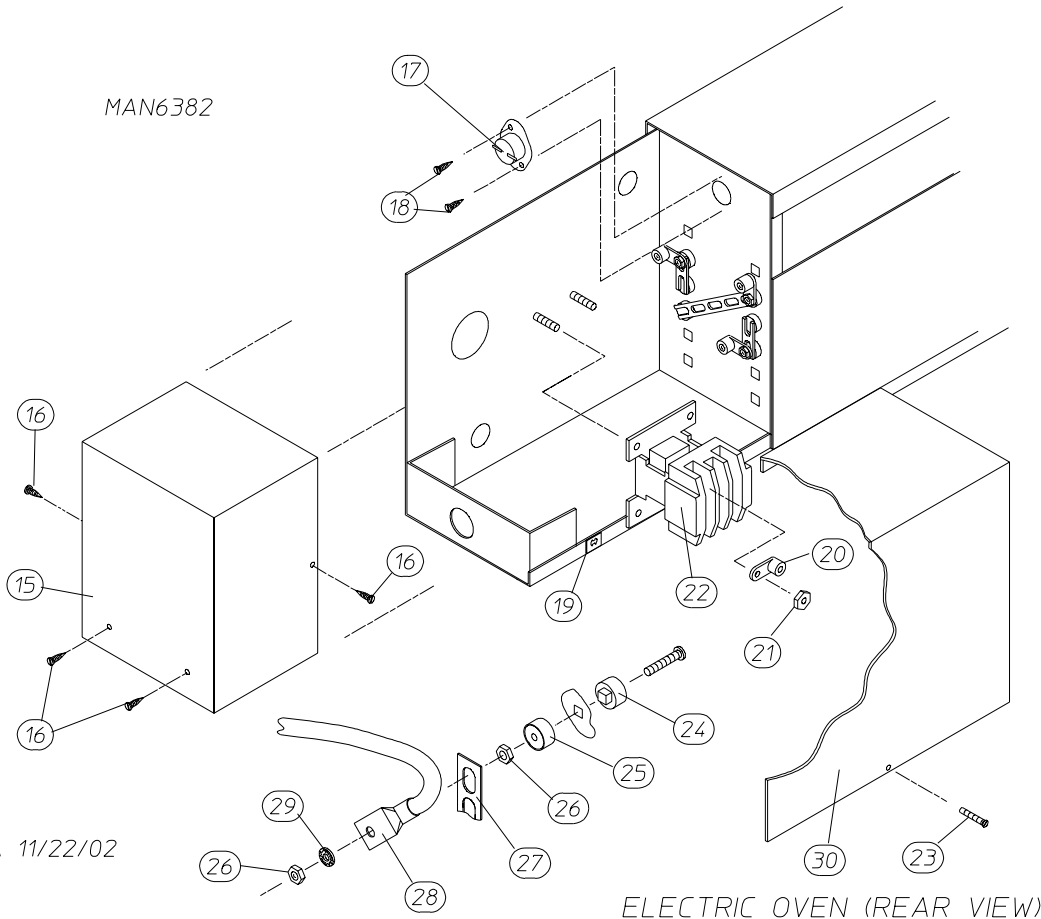

ELECTRIC OVEN (REAR VIEW)

<u>Illus. No.</u>	<u>Part No.</u>	<u>Qty.</u>	<u>Description</u>
1	803005	1	Large Electric Oven Box ONLY
	————*	1	Electric Oven Assembly Complete
2	————*	—	Electric Element
3	150300	2	#10-16 x 1/2" Hex Washer TEK Screw
4	802800	1	Sail Switch Box with Bracket and Cover ONLY
	802801	1	Sail Switch Box Assembly Complete (includes illus. nos. 4 through 12)
5	154004	1	Twin Speed Nut
6	150309	2	#10-16 x 1/2" Hex Head TEK Crimptite Screw
7	802799	1	Sail Switch Box Cover and Bracket ONLY
8	122200	1	Sail Switch ONLY
9	150303	2	#4 x 3/4" Pan Head "A" Machine Screw
10	105500	1	Sail Switch Actuator Rod
11	319202	1	Sail Switch Damper (flat)
12	154002	1	1/8" Push On Fastener
13	150300	2	#10-16 x 1/2" Hex Washer TEK Screw
14	803100	1	Electric Oven Front Cover ONLY
15	320611	1	Large Relay Box Cover ONLY
16	150301	2	#8-18 x 7/16" Phillips Pan Head TEK Screw
17	130400	1	290° Hi-Limit
18	150300	2	#10-16 x 1/2" Hex Washer TEK Screw
19	154001	1	#10-24 Speed Nut
20	121012	1	Terminal Lug for 110-8 Wire
21	152014	3	1/4-20 Free Spin Wash Nut
22	————*	1	Oven Relay
23	150207	2	#10-24 x 5/8" Truss Head Machine Screw
24	120081	—	Internal Ceramic Insulator (2 per element)
25	120080	—	External Ceramic Insulator (2 per element)
26	152008	—	#10-32 Hex Nut (4 per element)
27	121011*	—	Bus Bar
28	————**	—	Terminal Lug
29	153009	—	#10 Star Washer (2 per element)
30	320607	1	Large Electric Oven Right Side Cover ONLY

* Refer to Electric Oven Component Application Charts on page 49 and page 50.

** Consult factory for wiring harness required.

Sail Switch Assembly

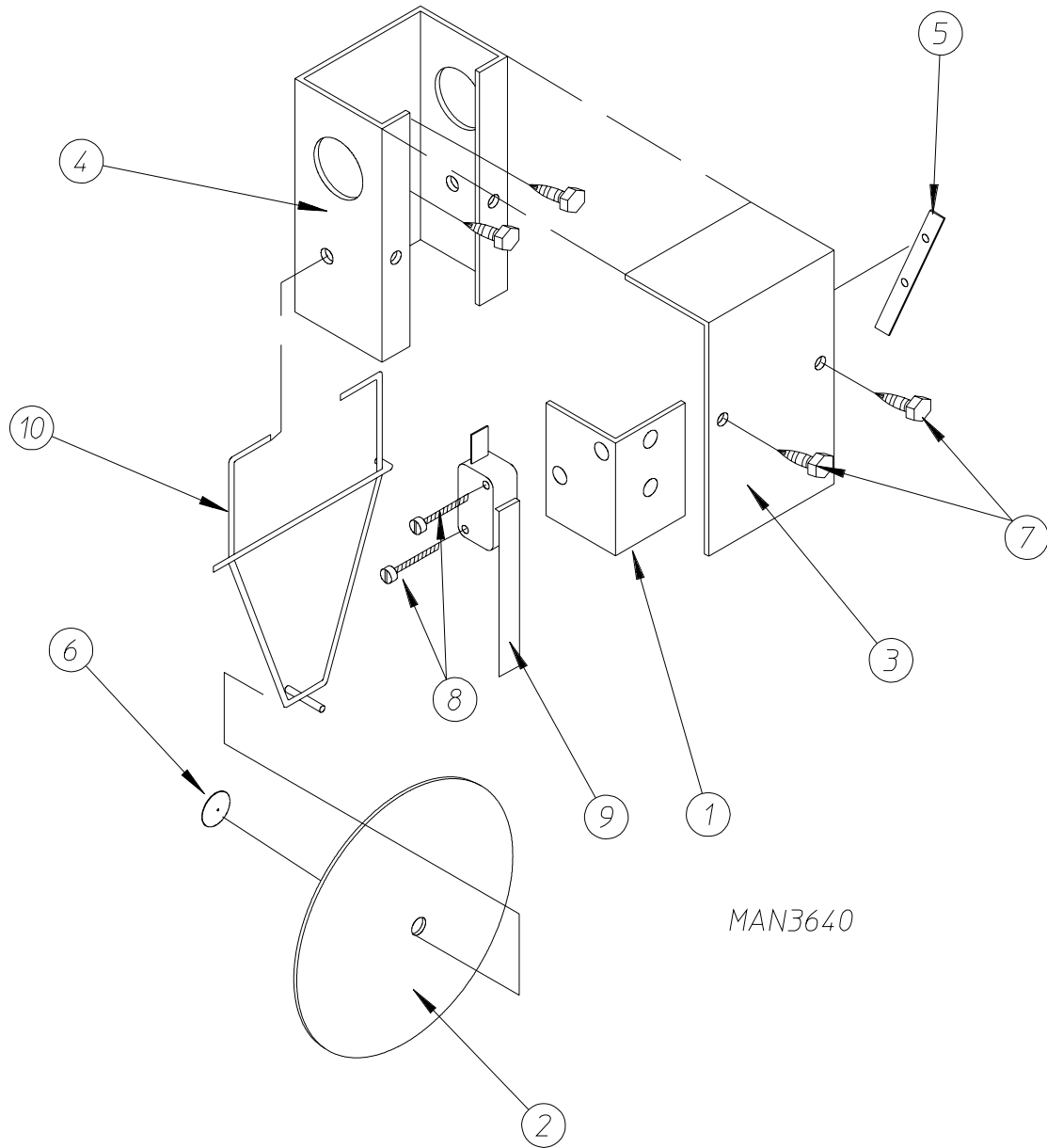

Illus. No.	Part No.	Qty.	Description
1	319203	1	Sail Switch Mounting Bracket
2	319202	1	Sail Switch Damper (flat)
3	319201	1	Sail Switch Box Cover
4	319200	1	Sail Switch Box
5	154004	1	Twin Speed Nut
6	154002	1	1/8" Push On Fastener
7	150309	4	#10-16 x 1/2" Hex Head TEK Crimptite Screw
8	150303	2	#4 x 3/4" Pan Head "A" Machine Screw
9	122200	1	Sail Switch ONLY
	802801	1	Sail Switch Box Assembly Complete (includes illus. nos. 1 through 10)
10	105500	1	Sail Switch Actuator Rod

Single-Phase (1 ϕ) Microprocessor Rear Electric Relay Panel Assembly

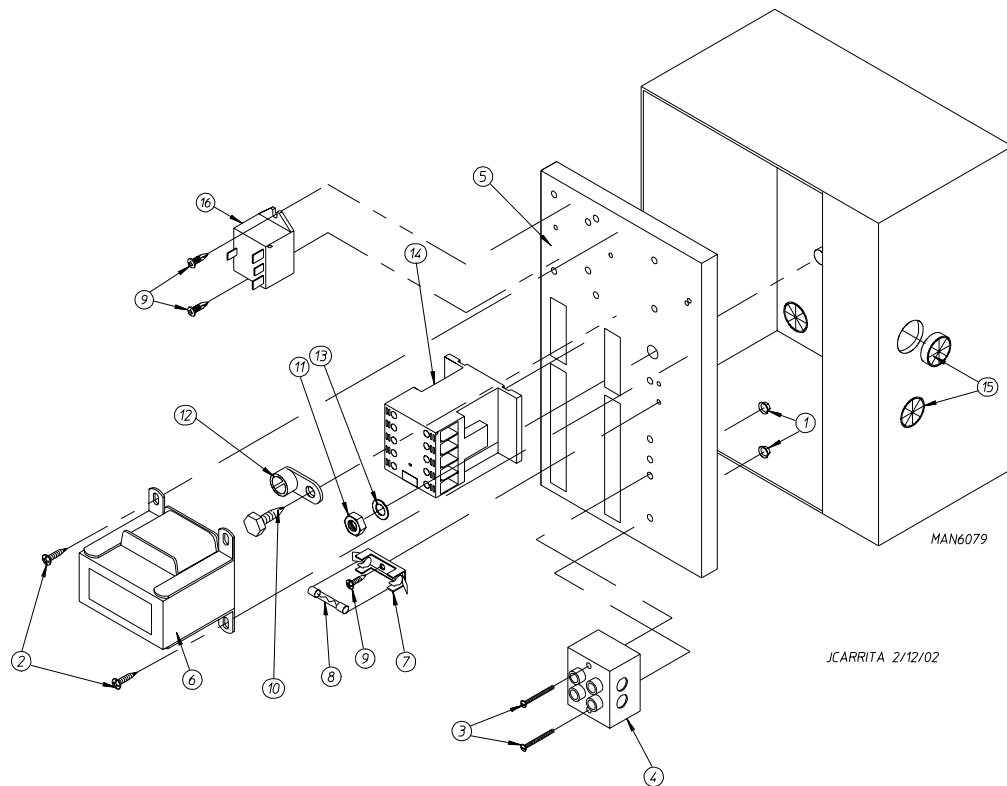

<u>Illus. No.</u>	<u>Part No.</u>	<u>Qty.</u>	<u>Description</u>
1	151000	2	#6-32 Pal Nut
2	150300	2	#10-16 x 1/2" Hex Washer TEK Screw
3	150009	2	#6-32 x 1-1/2" Phillips Pan Head Machine Screw
4	120716	1	2-Position Terminal Block
5	322812	1	Rear Electric Mounting Plate ONLY
	830468	1	Rear Electric Panel Assembly Complete – 115 Volt (1 ϕ) (for gas models Only) (includes illus. nos. 1 through 14)
	830477	1	Rear Electric Panel Assembly Complete – 115 Volt (1 ϕ) (for steam models Only) (includes illus. nos. 1 through 14)
	830469	1	Rear Electric Panel Assembly Complete – 208-240 Volt (1 ϕ) (for gas models Only) (includes illus. nos. 1 through 14)
	830478	1	Rear Electric Panel Assembly Complete – 208-240 Volt (1 ϕ) (for steam models Only) (includes illus. nos. 1 through 14)
	830131	1	Rear Electric Panel Assembly Complete – 208-240 Volt (for electric models Only) (includes illus. nos. 1 through 14 and 16)
6	132070	1	Transformer Assembly 115 – 208-240 Volt (for gas and steam models Only)
	822792	1	Transformer Assembly – 208-240 Volt (for electric models Only)
7	136008	*	Fuse Holder
8	136057	*	1/2-Amp (Slo-Blo) Fuse
9	150301	1	#8-18 x 7/16" Phillips Pan Head TEK Screw
10	150297	1	#10 x 1/2" Green Hex Washer TEK Screw
11	152004	1	5/16-18 Hex Nut
12	121010	1	L-70 Ground Lug
13	153002	1	5/16" Lock Washer
14	132514	1	3-Pole Contactor (115 volt models)
	132496	1	3-Pole Contactor (208-240 volt models)
15	121300	3	Open / Closed Bushing
16	131932	1	24V SPST Relay (for electric models Only)

* Quantity is 1 for 115v and 2 for 208-240v.

208-240V 3-Phase (3 ϕ) Microprocessor Rear Electric Relay Panel Assembly

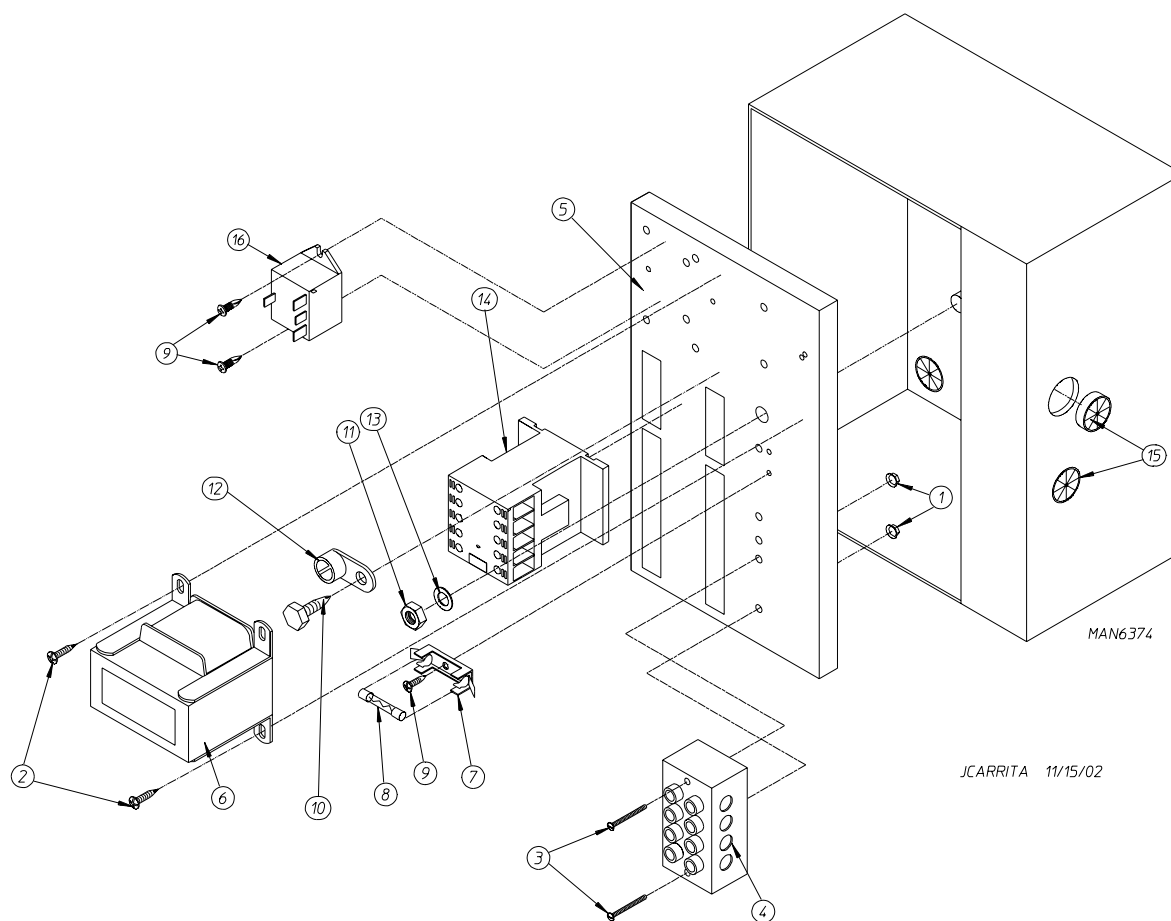

Illus. No.	Part No.	Qty.	Description
1	151000	2	#6-32 Pal Nut
2	150300	2	#10-16 x 1/2" Hex Washer TEK Screw
3	150008	2	#6-32 x 1-1/4" Phillips Pan Head Machine Screw
4	120701	1	4-Position Terminal Block
5	322812	1	Rear Electric Mounting Plate ONLY
	830470	1	Rear Electric Panel Assembly Complete – 208-240 Volt (for gas models Only) (includes illus. nos. 1 through 14)
	830480	1	Rear Electric Panel Assembly Complete – 208-240 Volt (for steam models Only) (includes illus. nos. 1 through 14)
	830157	1	Rear Electric Panel Assembly Complete – 208-240 Volt (for electric models Only) (includes illus. nos. 1 through 14 and 16)
6	132070	1	Transformer (for gas and steam models Only)
	822792	1	Transformer (for electric models Only)
7	136008	2	Fuse Holder
8	136057	2	1/2-Amp (Slo-Blo) Fuse
9	150301	4	#8-18 x 7/16" Phillips Pan Head TEK Screw
10	150297	1	#10 x 1/2" Green Hex Washer TEK Screw
11	152004	1	5/16-18 Hex Nut
12	121010	1	L-70 Ground Lug
13	153002	1	5/16" Lock Washer
14	132495	1	3-Pole Contactor
15	121300	3	Open / Closed Bushing
16	131932	1	24V SPST Relay (for electric models Only)

460-480V Microprocessor Rear Electric Relay Panel Assembly

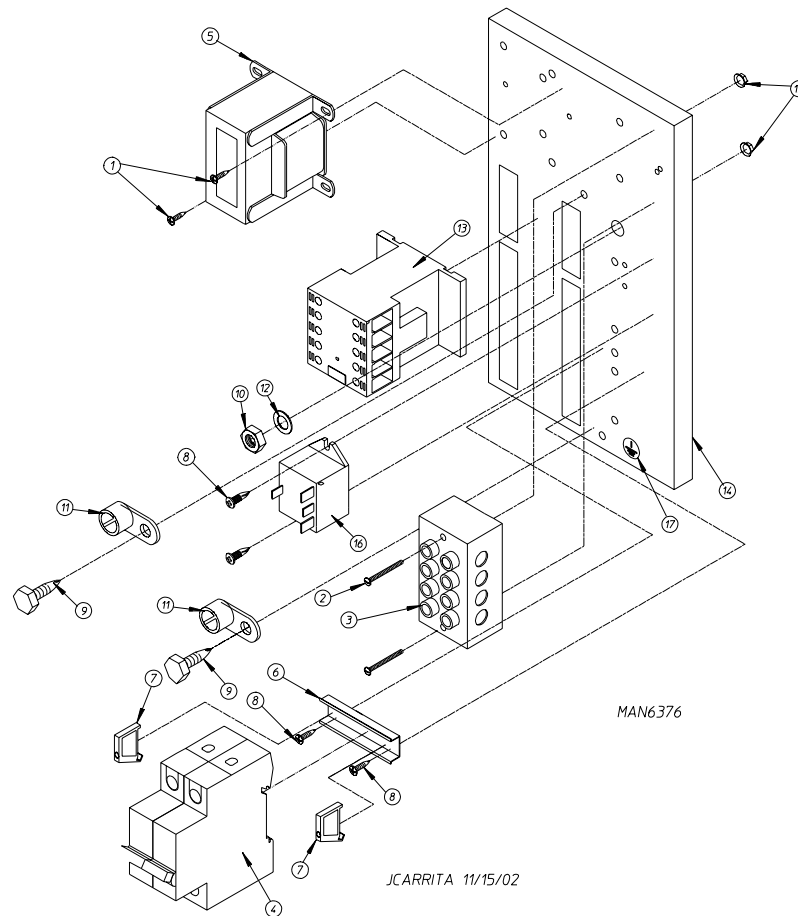

Illus. No.	Part No.	Qty.	Description
1	150300	2	#10-16 x 1/2" Hex Washer TEK Screw
2	150008	2	#6-32 x 1-1/4" Phillips Pan Head Machine Screw
3	120701	1	4-Position Terminal Block
4	135501	1	2-Pole 1-Amp Circuit Breaker
5	132067	1	Transformer 460-480 Volt
6	120768	2	35 x 15mm Din Rail
7	120765	2	Standard End Bracket
8	150301	4	#8-18 x 7/16" Phillips Pan Head TEK Screw
9	150297	2	#10 x 1/2" Green Hex Washer TEK Screw
10	152004	1	5/16-18 Hex Nut
11	121010	2	L-70 Ground Lug
12	153002	1	5/16" Lock Washer
13	132495	1	3-Pole Contactor
14	322812	1	Rear Electric Mounting Plate ONLY
	830474	1	Rear Electric Panel Assembly Complete – 460-480 Volt (for gas models Only) (includes illus. nos. 1 through 14)
	830486	1	Rear Electric Panel Assembly Complete – 460-480 Volt (for steam models Only) (includes illus. nos. 1 through 14)
	830199	1	Rear Electric Panel Assembly Complete – 460-480 Volt (for electric models Only) (includes illus. nos. 1 through 14)
15	151000	2	#6-32 Pal Nut
16	131932	1	24V SPST Relay (for electric models Only)
17	112075	1	Ground Label

208-240V Microprocessor Reversing Rear Electric Relay Panel Assembly

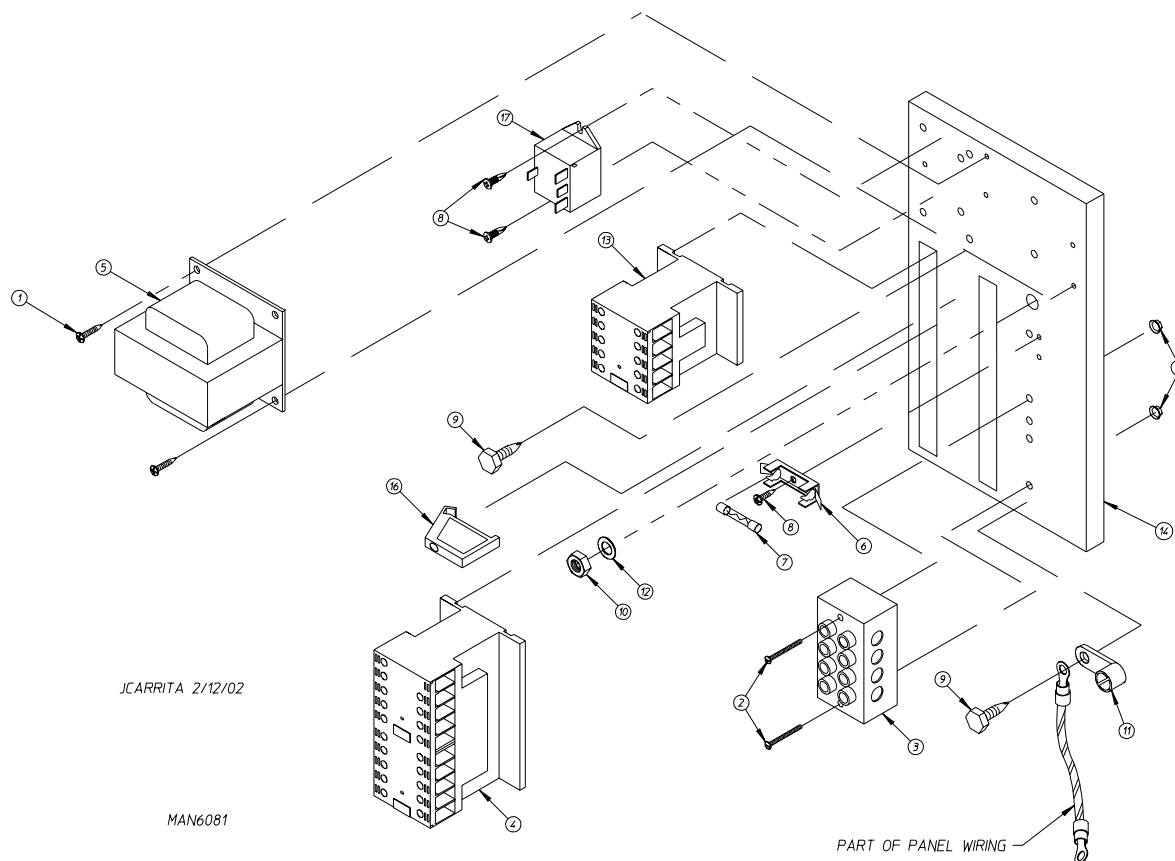

Illus. No.	Part No.	Qty.	Description
1	150300	2	#10-16 x 1/2" Hex Washer TEK Screw
2	150008	2	#6-32 x 1-1/4" Phillips Pan Head Machine Screw
3	120701	1	4-Position Terminal Block
4	132497	1	3-Pole Reversing Contactor
5	822764	1	Transformer 208-240 Volt (for gas and steam models Only)
	822792	1	Transformer 208-240 Volt (for electric models Only)
6	136008	2	Fuse Holder
7	136057	2	1/2-Amp (Slo-Blo) Fuse
8	150301	4	#8-18 x 7/16" Phillips Pan Head TEK Screw
9	150297	2	#10 x 1/2" Green Hex Washer TEK Screw
10	152004	1	5/16-18 Hex Nut
11	121010	1	L-70 Ground Lug
12	153002	1	5/16" Lock Washer
13	132495	1	3-Pole Contactor
14	322812	1	Rear Electric Mounting Plate ONLY
	830471	1	Rear Electric Panel Assembly Complete – 208-240 Volt (3ø) (for gas models Only) (includes illus. nos. 1 through 16)
	830482	1	Rear Electric Panel Assembly Complete – 208-240 Volt (3ø) (for steam models Only) (includes illus. nos. 1 through 16)
	822789	1	Rear Electric Panel Assembly Complete – 208-240 Volt (3ø) (for electric models Only) (includes illus. nos. 1 through 17)
15	151000	2	#6-32 Pal Nut
16	120765	1	Standard End Bracket
17	131932	1	24V SPST Relay (for electric models Only)

460-480V Microprocessor Reversing Rear Electric Relay Panel Assembly

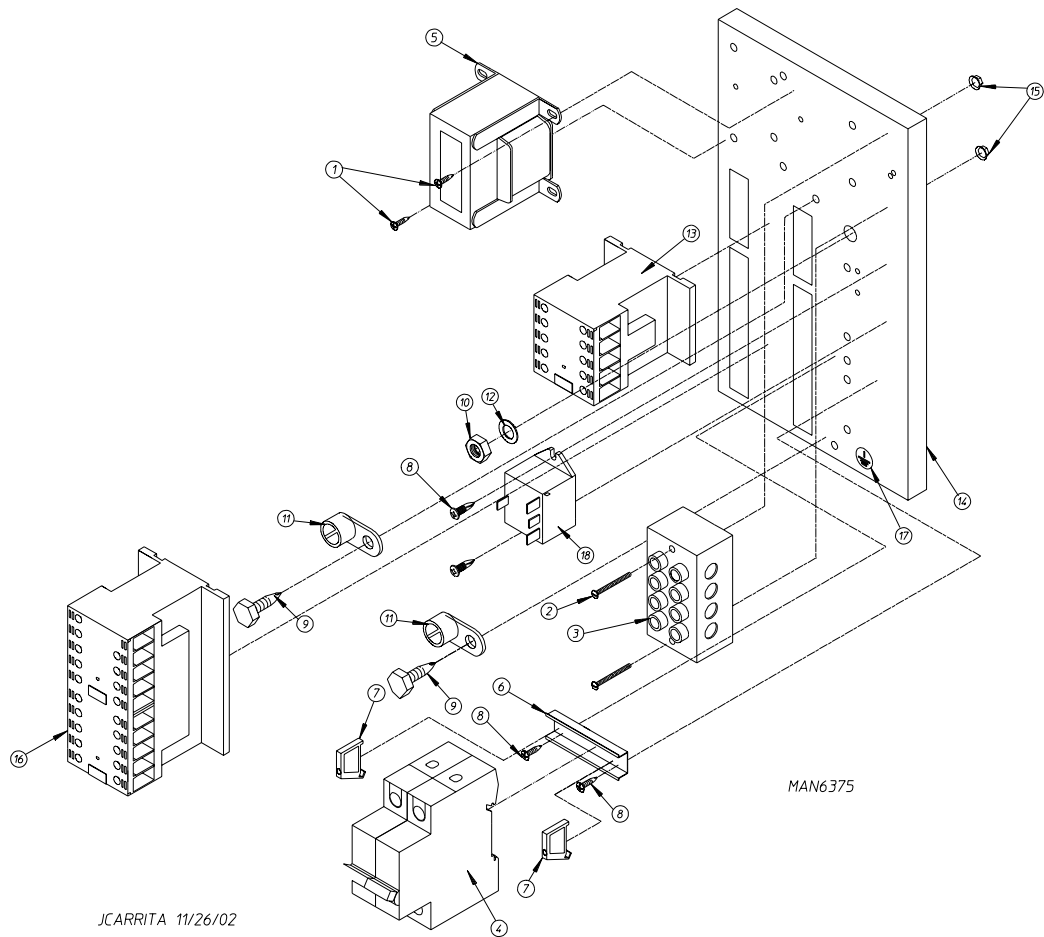

<u>Illus. No.</u>	<u>Part No.</u>	<u>Qty.</u>	<u>Description</u>
1	150300	2	#10-16 x 1/2" Hex Washer TEK Screw
2	150009	2	#6-32 x 1-1/2" Phillips Pan Head Machine Screw
3	120701	1	4-Position Terminal Block
4	135501	1	2-Pole 1-Amp Circuit Breaker
5	132067	1	Transformer 460-480 Volt
6	120768	2	35 x 15mm Din Rail
7	120765	2	Standard End Bracket
8	150301	4	#8-18 x 7/16" Phillips Pan Head TEK Screw
9	150297	2	#10 x 1/2" Green Hex Washer TEK Screw
10	152004	1	5/16-18 Hex Nut
11	121010	2	L-70 Ground Lug
12	153002	1	5/16" Lock Washer
13	132495	1	3-Pole Contactor
14	322812	1	Rear Electric Mounting Plate ONLY
	830475	1	Rear Electric Panel Assembly Complete – 460-480 Volt (for gas models Only) (includes illus. nos. 1 through 16)
	830487	1	Rear Electric Panel Assembly Complete – 460-480 Volt (for steam models Only) (includes illus. nos. 1 through 16)
	824371	1	Rear Electric Panel Assembly Complete – 460-480 Volt (for electric models Only) (includes illus. nos. 1 through 17)
15	151000	2	#6-32 Pal Nut
16	132497	1	3-Pole Reversing Contactor
17	112075	1	Ground Label
18	131932	1	24V SPST Relay (for electric models Only)

Single-Phase (1Ø) Dual Timer Rear Electric Relay Panel Assembly

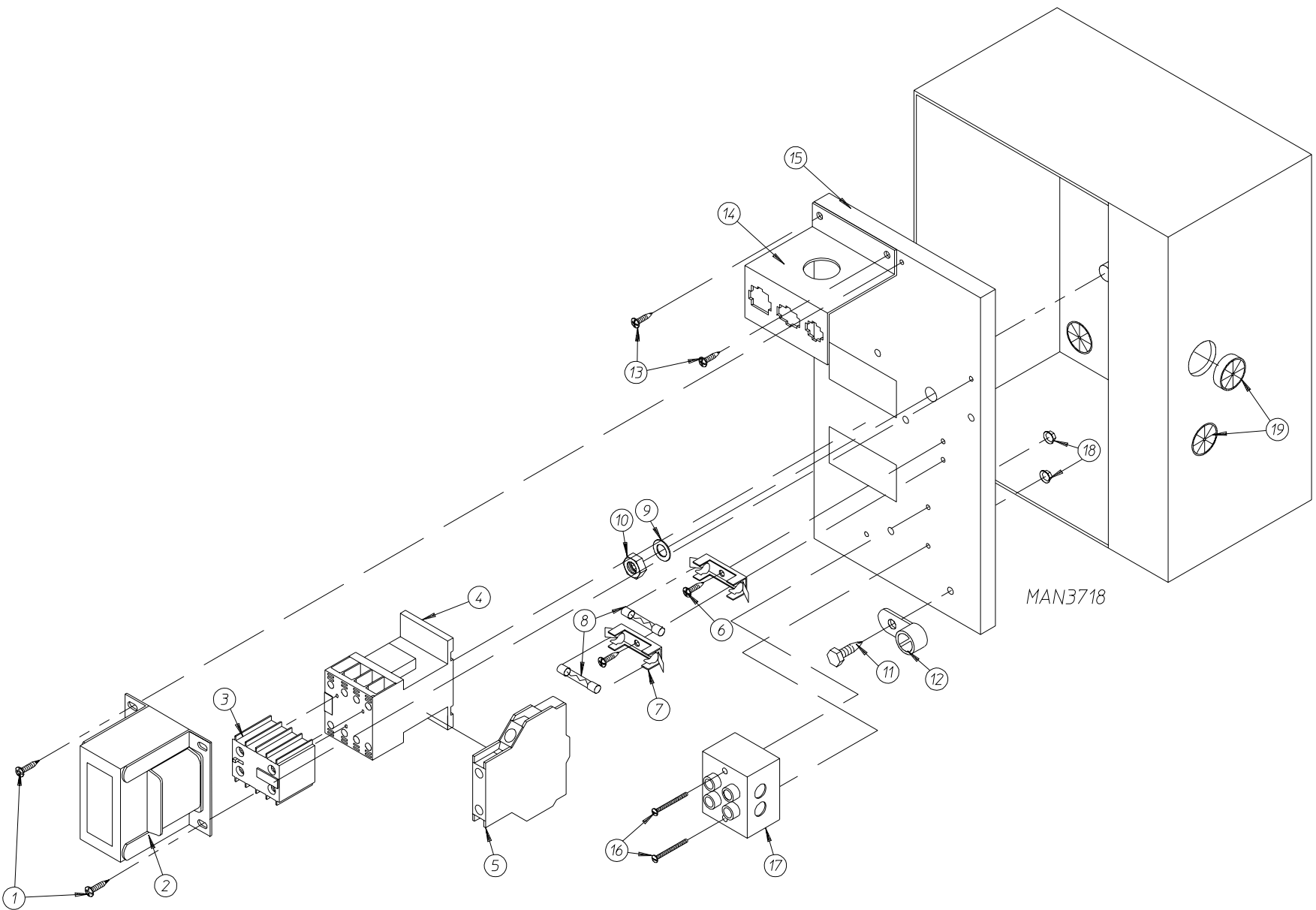

Single-Phase (1 ϕ) Dual Timer Rear Electric Relay Panel Assembly

<u>Illus. No.</u>	<u>Part No.</u>	<u>Qty.</u>	<u>Description</u>
1	150300	2	#10-16 x 1/2" Hex Washer TEK Screw
2	825462	1	24 VAC Transformer (for 115 volt gas models Only)
	825463	1	24 VAC Transformer (for 208-240 volt models Only)
3	132449	1	2-Pole Contact Block (for 208-240 volt models Only)
4	132445	1	3-Pole Contactor
5	132383	1	2-Pole Contact Block (for 120 volt models Only)
6	150301	*	#8-18 x 7/16" Phillips Pan Head TEK Screw
7	136008	*	Fuse Holder
8	136049	*	3/4-Amp (Slo-Blo) Fuse
9	153002	1	5/16" Lock Washer
10	152004	1	5/16-18 Hex Nut
11	150297	1	#10 x 1/2" Green Hex Washer TEK Screw
12	121010	1	L-70 Ground Lug
13	150300	2	#10-16 x 1/2" Hex Washer TEK Screw
14	353258	1	Rear Panel Connector Bracket
15	306304	1	Rear Electric Mounting Panel ONLY
	825445	1	Rear Electric Panel Assembly Complete – 115 Volt (for gas models Only) (includes illus. nos. 1, 2, and 4 through 18)
	825446	1	Rear Electric Panel Assembly Complete – 208-240 Volt (for gas models Only) (includes illus. nos. 1 through 4 and 6 through 18)
16	150009	2	#6-32 x 1-1/2" Phillips Round Head Machine Screw
17	120716	1	2-Position Terminal Block
18	151000	2	#6-32 Pal Nut
19	121300	3	Open / Closed Bushing

* Quantity is 1 for 115v and 2 for 208-240v.

460-480V Dual Timer Rear Electric Relay Panel Assembly

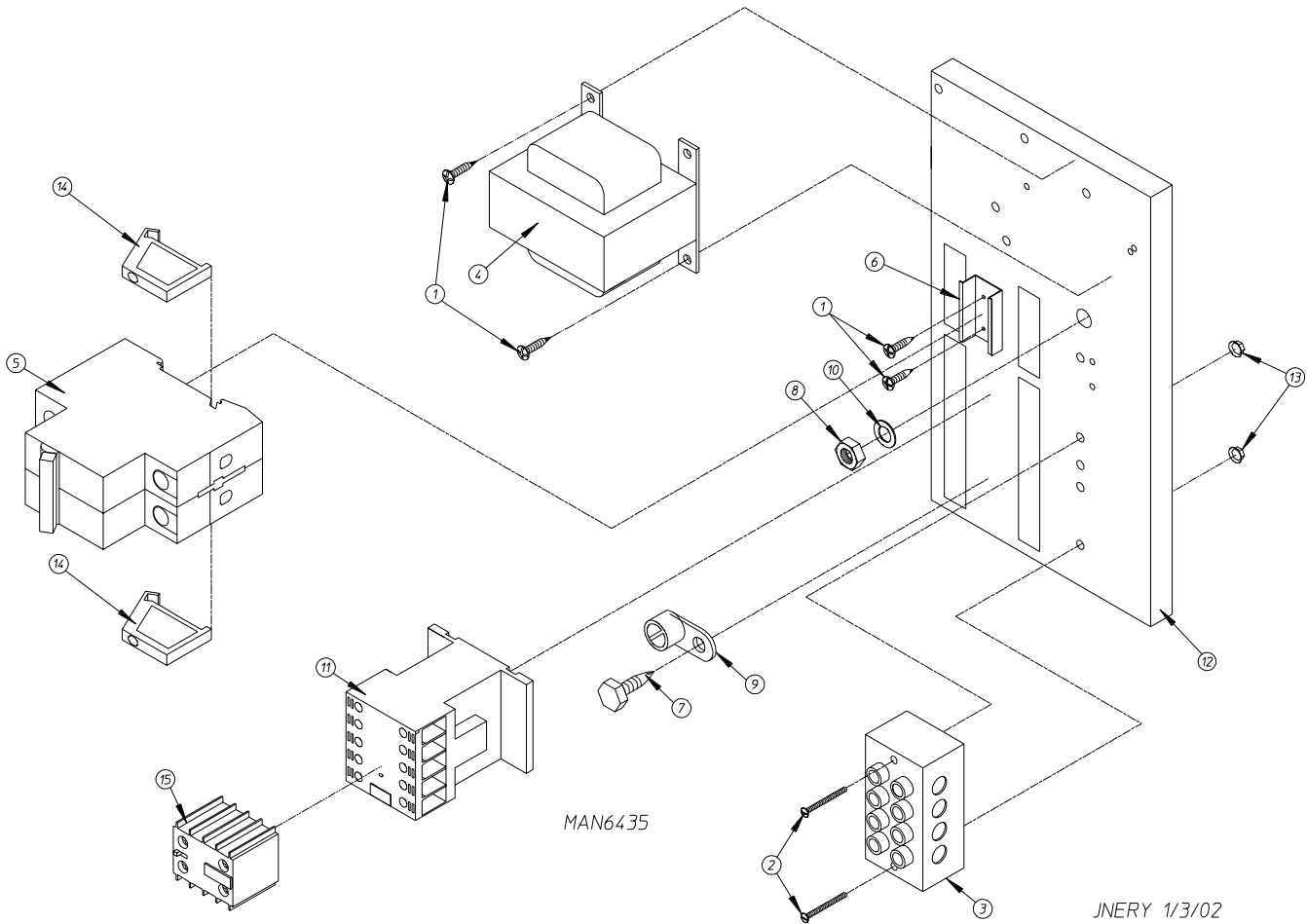

Illus. No.	Part No.	Qty.	Description
1	150300	2	#10-16 x 1/2" Hex Washer TEK Screw
2	150009	2	#6-32 x 1-1/2" Phillips Round Head Machine Screw
3	120701	1	4-Position Terminal Block
4	835143	1	24 VAC Transformer (for gas models Only)
5	135501	1	2-Pole 1-Amp Circuit Breaker
6	120768	2	35 x 15mm Din Rail
7	150297	1	#10 x 1/2" Green Hex Washer TEK Screw
8	152004	1	5/16-18 Hex Nut
9	121010	1	L-70 Ground Lug
10	153002	1	5/16" Lock Washer
11	132447	1	3-Pole Contactor
12	322812	1	Rear Electric Mounting Panel ONLY
	824231	1	Rear Electric Panel Assembly Complete (for gas models Only) (includes illus. nos. 1 through 15)
13	151000	2	#6-32 Pal Nut
14	120765	2	Standard End Bracket
15	132449	1	2-Pole Contact Block

208-240V Dual Timer Reversing Rear Electric Relay Panel Assembly

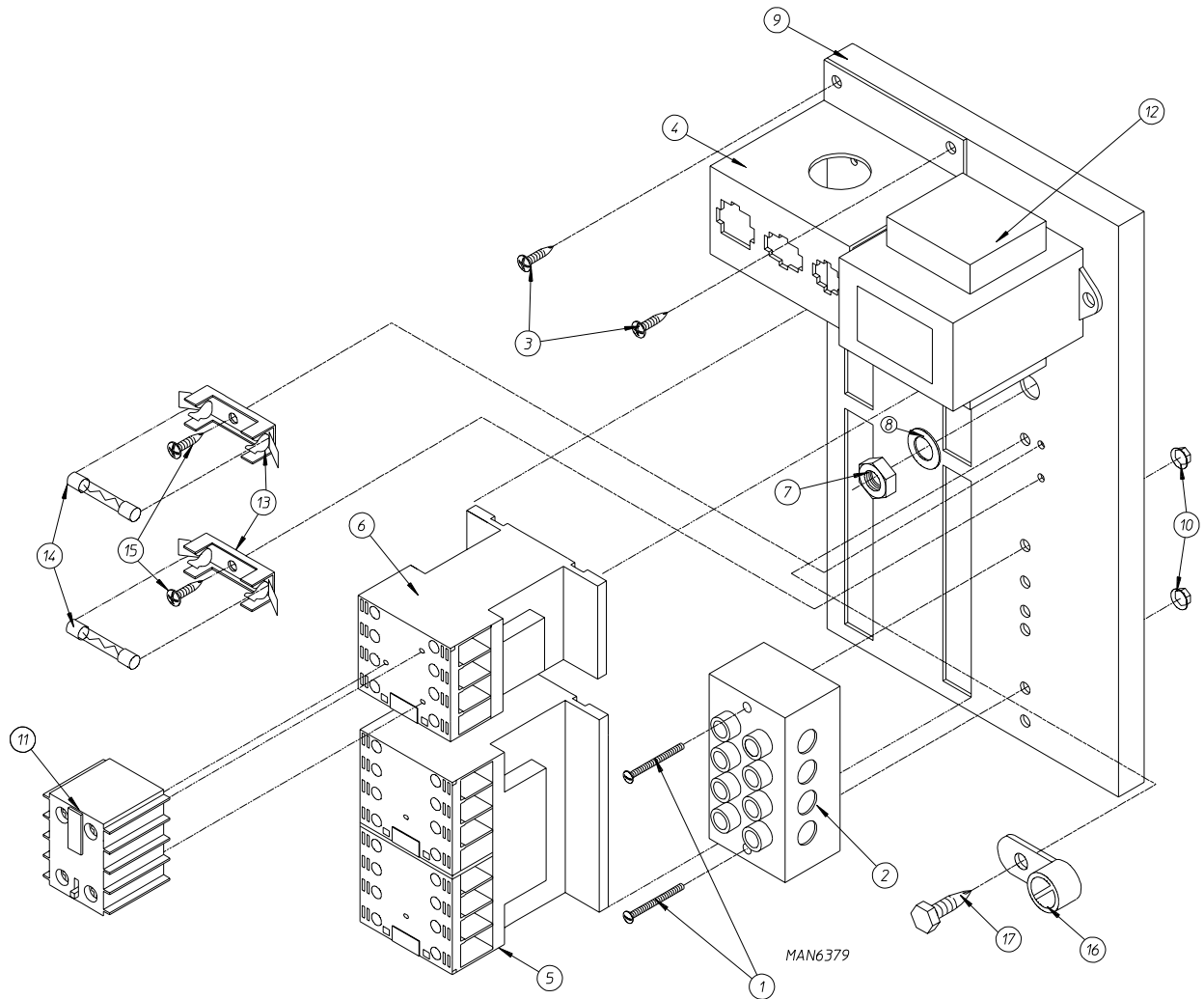

JCARRITA 11/15/02

Illus. No.	Part No.	Qty.	Description
1	150009	2	#6-32 x 1-1/2" Phillips Round Head Machine Screw
2	120701	1	4-Position Terminal Block
3	150300	2	#10-16 x 1/2" Hex Washer TEK Screw
4	353258	1	Rear Panel Connector Bracket
5	132497	1	Reversing Contactor
6	132495	1	Blower Motor Contactor
7	152004	1	5/16-18 Hex Nut
8	153002	1	5/16" Lock Washer
9	322812	1	Rear Electric Mounting Panel ONLY
	830236	1	Rear Electric Panel Assembly Complete (for gas models Only) (includes illus. nos. 1 through 17)
10	151000	2	#6-32 Pal Nut
11	132449	1	2-Pole Contact Block
12	830238	1	24 VAC Transformer (for gas models Only)
13	136008	2	Fuse Holder
14	136057	2	1/2-Amp (Slo-Blo) Fuse
15	150301	2	#8-18 x 7/16" Phillips Pan Head TEK Screw
16	121010	1	L-70 Ground Lug
17	150297	1	#10 x 1/2" Green Hex Washer TEK Screw

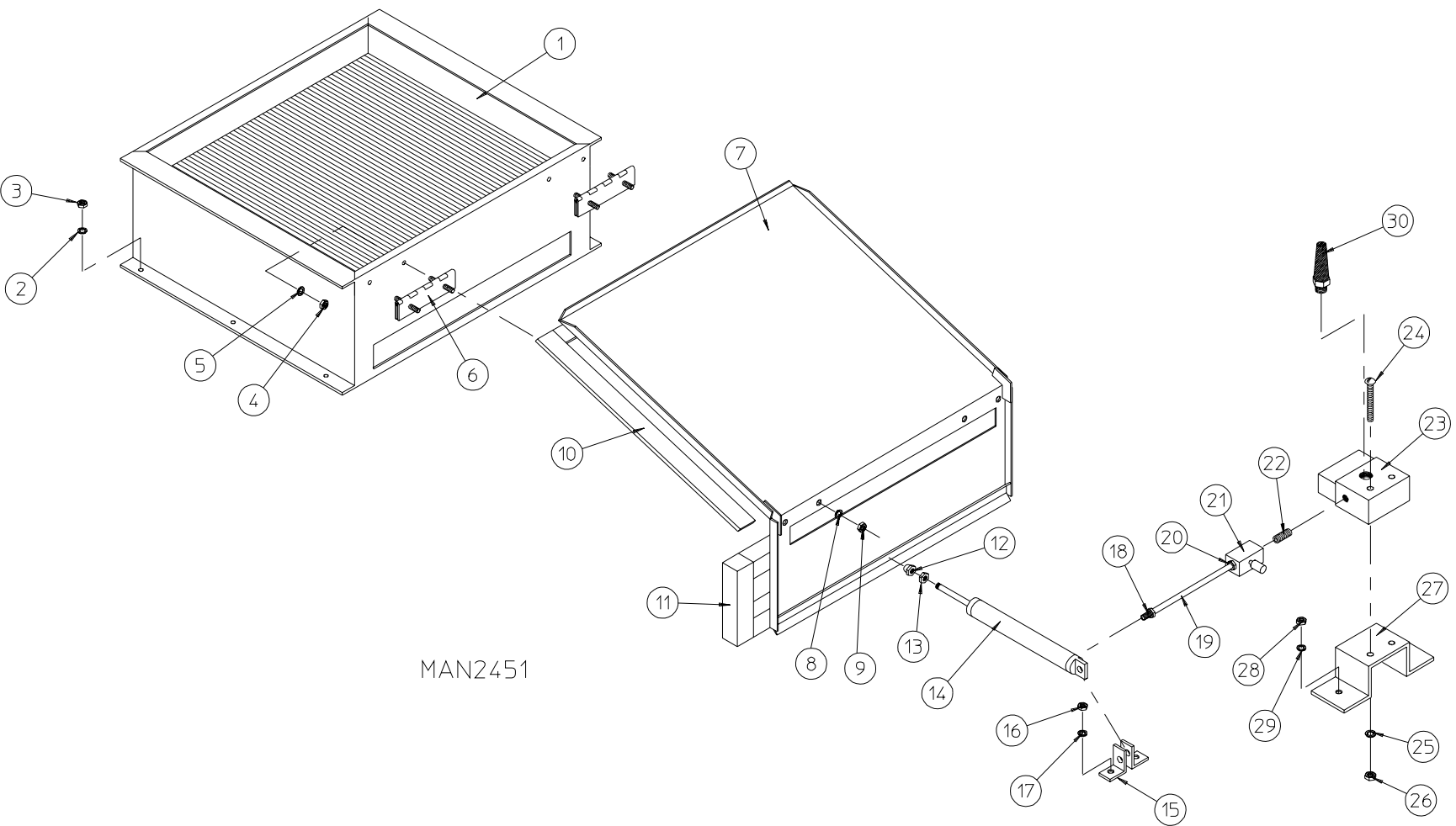

MAN2451

Air-Operated Steam Damper Assembly

<u>Illus. No.</u>	<u>Part No.</u>	<u>Qty.</u>	<u>Description</u>
1	165009	1	Steam Coil Assembly
2	153002	6	5/16" Lock Washer
3	152004	6	5/16-18 Hex Nut
4	152002	4	1/4-20 Hex Nut
5	153007	4	1/4" Lock Washer
6	820321	2	Steam Damper Hinge Assembly
7	803415	1	Steam Damper Assembly (includes illus. nos. 7, 10, and 11)
8	153007	4	1/4" Lock Washer
9	152002	4	1/4-20 Hex Nut
10	115995	108	Steam Damper Gasket (sold by the inch)
11	102350	1	Steam Damper Foam (68-1/2" length)
12	151007	1	7/16-20 Stainless Steel Acorn Nut
13	152007	1	7/16-20 Hex Nut
14	100497	1	1-1/4" Bore x 3" Stroke Piston
15	100492	1	Piston Support Bracket
16	152002	4	1/4-20 Hex Nut
17	153007	4	1/4" Lock Washer
18	100472	1	1/4" x 1/8" Connector
19	143110	1	1/4" Tubing (sold by the foot)
20	100472	1	1/4" x 1/8" Connector
21	100496	1	1/8" Needle Valve
22	143238	1	1/8" Close Nipple
23	100498	1	3-Way Micro Valve – 24 VAC
24	150002	2	#6-32 x 1" Phillips Round Head Machine Screw
25	153010	2	#6 Star Washer
26	152000	2	#6-32 Hex Nut
27	330987	1	Micro Valve Support Bracket
28	152002	2	1/4-20 Hex Nut
29	153007	2	1/4" Lock Washer
30	100520	1	1/8" N.P.T. Silencer (muffler)

Fire Suppression System Assemblies

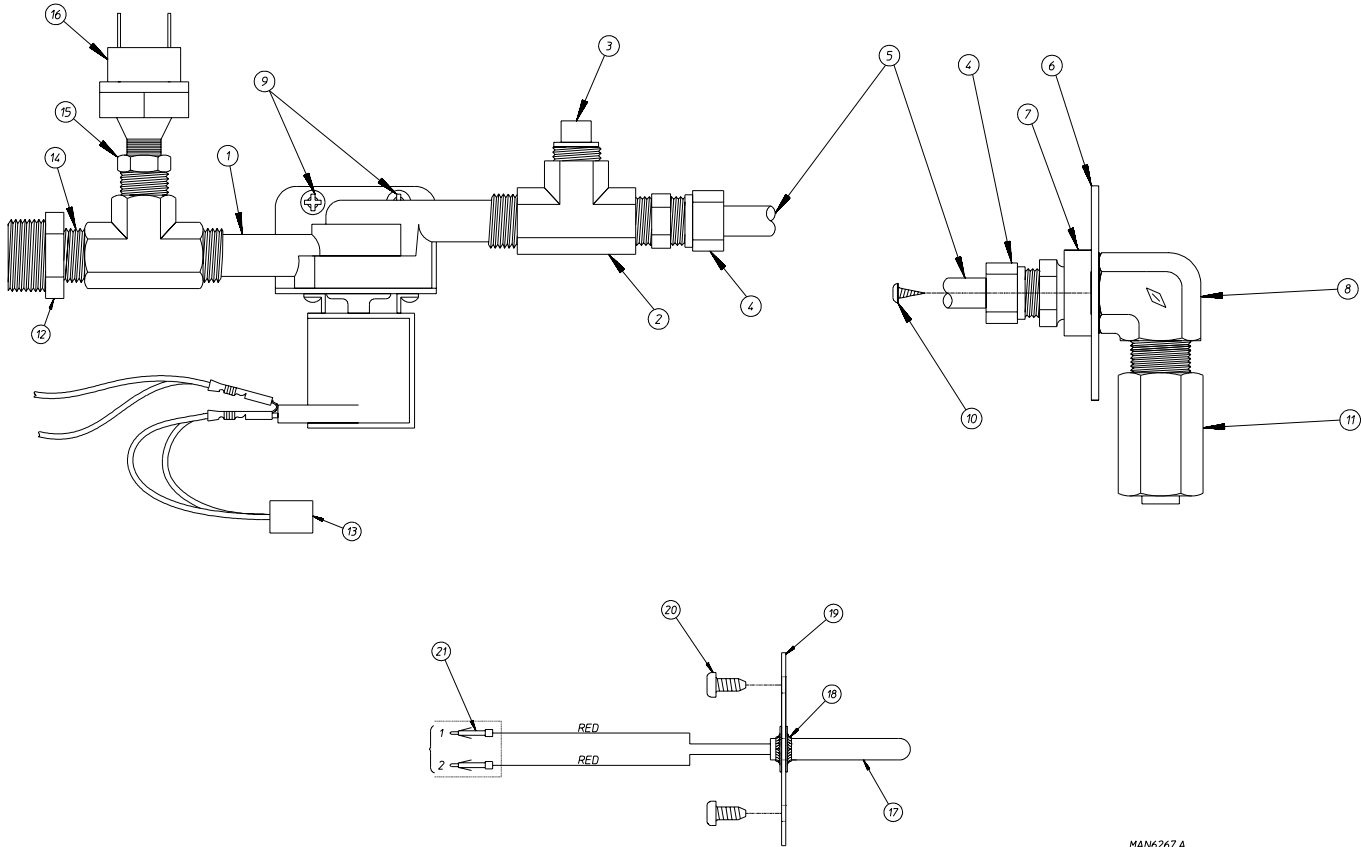

MAN6267.A

Illus. No.	Part No.	Qty.	Description
1	165114	1	Fire Suppression System Solenoid Valve 24V 50/60 Hz
2	143220	1	3/8" F.P.T. Brass Tee
3	143251	1	3/8" M.P.T. Brass Plug
4	143208	2	3/8" Comp x 3/8" M.P.T. Brass Connector
5	143099	6'	3/8" OD x 0.035 Wall Copper Tubing (sold by the foot)
6	311588	1	Sprinkler Head Mounting Plate
7	143303	1	3/8" N.P.T. Brass Locknut
8	143155	1	3/8" Brass Elbow 90°
9	150430	2	#10 x 1/2" Self-Drilling Screw
10	150301	2	#8-18 x 7/16" TEK Screw
11	143581	1	3 GPM 3/8" F.P.T. Spray Nozzle
12	143025	1	3/8 x 3/4 NH 60 Hz
	143177		3/4 M.P.T. x 3/8 Adapt 50 Hz
13	824081	1	R.C. Network Assembly
14	143241	1	3/8" x Close Brass Nipple
15	143315	1	3/8" M.N.P.T. x 1/8" F.N.P.T. Brass Bushing
16	136987	1	Water Jet Pressure Switch (for models mfd. as of December 1, 2003)
17	822752	1	Fire Suppression System Temperature Probe Assembly (includes illus. nos. 17 through 19 and 21)
18	154007	2	Push-On Fastener
19	390390	1	Sensor Bracket ONLY
20	150301	2	#8-18 x 7/16" Phillips Pan Head TEK Screw
21	122647	1	Connector ONLY (does not include terminals)

Outer Top / Back Guard Assemblies

For Models Mfd. as of January 5, 2003

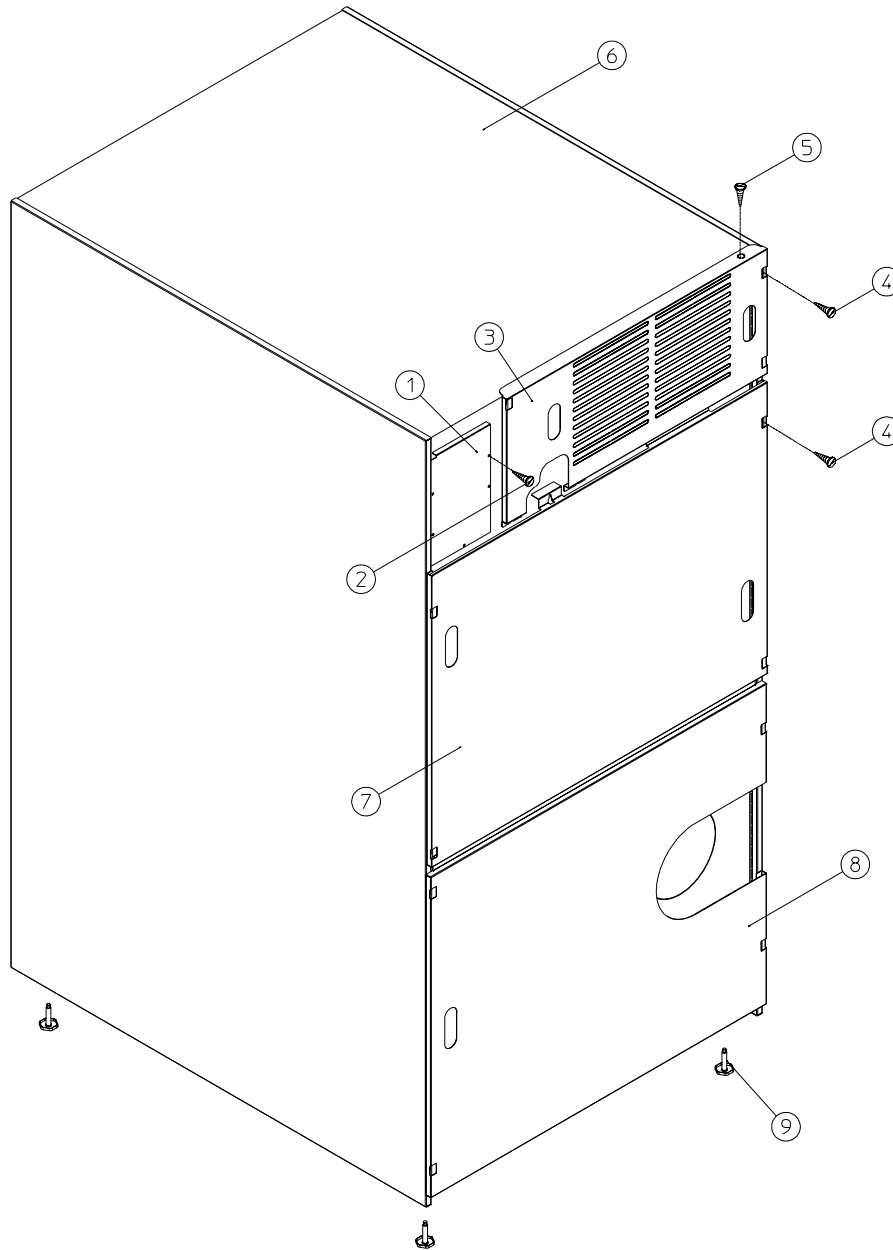

MAN7536

<u>Illus. No.</u>	<u>Part No.</u>	<u>Qty.</u>	<u>Description</u>
1	322809	1	Back Electrical Box Cover
2	150301	4	#8-18 x 7/16" Phillips Pan Head TEK Screw
3*	314534	1	Top Back Guard (for gas models Only)
	314540	1	Top Back Guard (for electric models Only)
4	150301	7	#8-18 x 7/16" Phillips Pan Head TEK Screw
5	150300	10	#10-16 x 1/2" Hex Washer TEK Screw
6*	312527	1	Outer Top (for gas models Only)
	320007	1	Outer Top (for electric models Only)
7	314535	1	Middle Back Guard
8	314539	1	Bottom Back Guard
9	103500	4	Leveling Leg

* There is no outer top or top back guard on steam models.

Outer Top / Back Guard Assemblies

For Models Mfd. prior to January 5, 2003

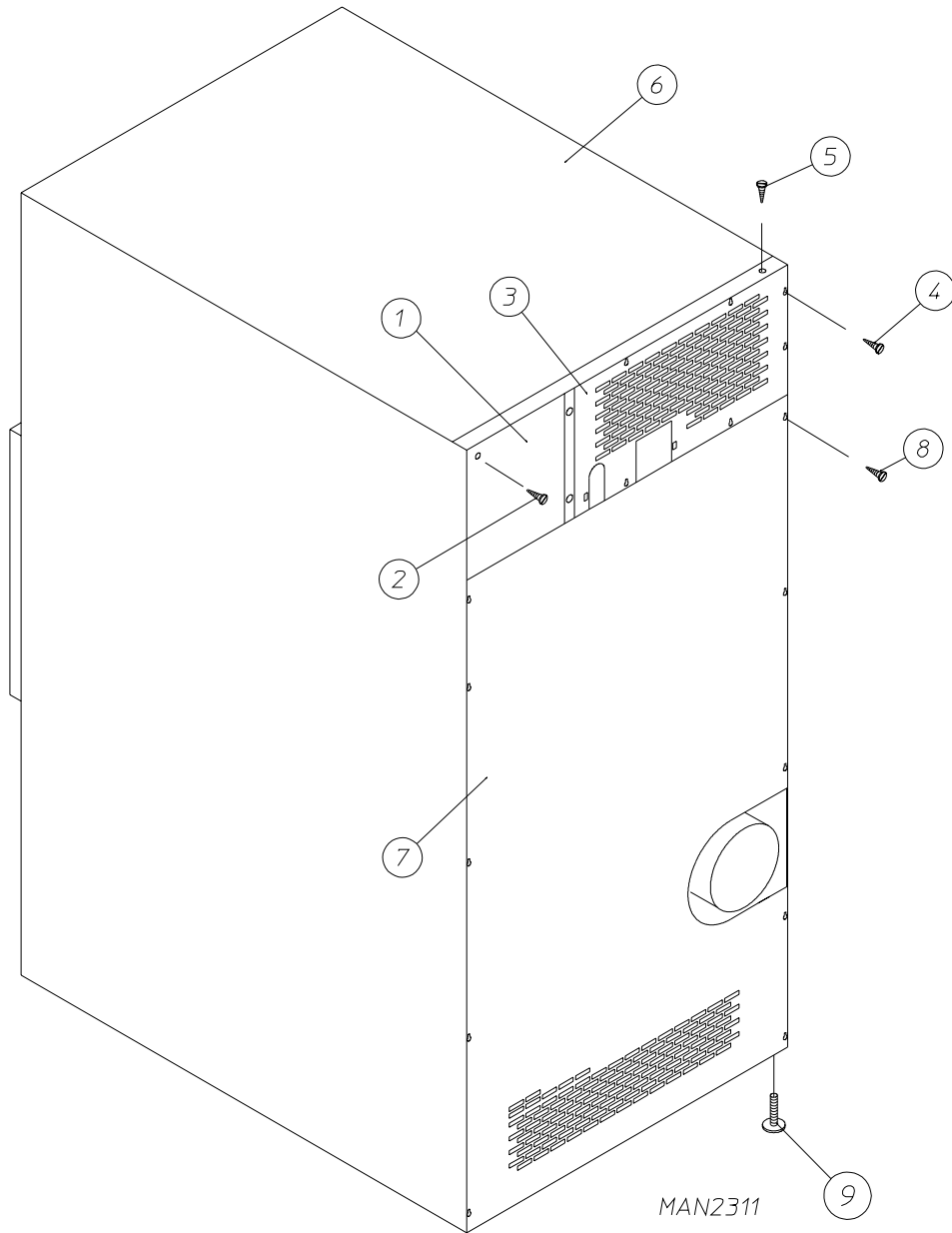

Illus. No.	Part No.	Qty.	Description
1	322809	1	Back Electrical Box Cover
2	150301	4	#8-18 x 7/16" Phillips Pan Head TEK Screw
3*	323738	1	Top Back Guard (for gas models Only)
	320008	1	Top Back Guard (for electric models Only)
4	150301	7	#8-18 x 7/16" Phillips Pan Head TEK Screw
5	150300	10	#10-16 x 1/2" Hex Washer TEK Screw
6*	312527	1	Outer Top (for gas models Only)
	320007	1	Outer Top (for electric models Only)
7	314518	1	Bottom Back Guard
8	150301	13	#8-18 x 7/16" Phillips Pan Head TEK Screw
9	103500	4	Leveling Leg

* There is no outer top or top back guard on steam models.

kW	Volt	Phase	Wire	Oven Assembly * Part No.	Elements			Oven Wire			Terminal Lug		Bus Bar P/N 121011	Oven Relay
					Qty.	kW	Part No.	Qty.	Size	Part No.	Qty.	Part No.		Part No.
36	480	3∅	3 or 4	824408	6	6	120014	1	#8	882572	1	121010	1	131359
33	380	3∅	3 or 4	830904	6	6	120002	1	#6	830403	1	121010	1	131359
30	208	3∅	3 or 4	835060	6	5	120012	1	#2	823066	1	121010	1	131362
30	240	3∅	3	833124	6	5	120013	1	#4	882566	1	121010	1	131363
30	480	3∅	3 or 4	826222	6	5	120013	1	#8	882572	1	121010	1	131357
25	380	3∅	3 or 4	833136	6	5	120013	1	#8	882571	1	121010	1	131357
24	208	3∅	3 or 4	835054	6	4	120010	1	#4	882566	1	121010	1	131363

* Consult factory for oven assemblies not listed.

kW	Volt	Phase	Wire	Oven Assembly * Part No.	Elements			Oven Wire			Terminal Lug		Bus Bar P/N 121011	Oven Relay
					Qty.	kW	Part No.	Qty.	Size	Part No.	Qty.	Part No.		Part No.
36	208	3ø	3 or 4	824921	6	6	120015	1	#2	823066	1	121010	1	131362
36	240	3ø	3	824026	6	6	120014	1	#2	882562	1	121010	1	131362
36	460/480	3ø	3 or 4	802764	6	6	120014	1	#8	882572	1	121010	1	131359
33	380	3ø	3 or 4	827044	6	6	120002	1	#6	882568	1	121033	1	131359
30	208	3ø	3 or 4	825376	6	5	120012	1	#2	823066	1	121010	1	131362
30	240	3ø	3	840259	6	5	120013	1	#4	882566	1	121010	1	131363
30	416	3ø	3 or 4	835064	6	5	120013	1	#8	882571	1	121010	1	131357
30	460/480	3ø	3 or 4	834804	6	5	120013	1	#8	882572	1	121010	1	131357
24	208	3ø	3 or 4	816138	6	4	120010	1	#4	882566	1	121010	1	131363

* When ordering oven assembly complete, specify 3-wire or 4-wire when applicable, as well as if dryer has microprocessor controller (computer) or non-microprocessor controls.

<u>Part No.</u>	<u>Description</u>
112075	1/2" Dia. Ground Symbol Label
112280	"Clean Lint Screen" Label
114001	"CAUTION – Exhaust / Lint Screen" Label
114006	"WARNING – Fire Hazards" Label
117505	Aluminum Duct Tape (sold by the foot)
120100	3/8" Straight (BX) Connector
120400	3/8" Red Jacket (BX) Insulator
120500	3/8" Jiffy Clip (BX retainer clip)
120600	3/8" Greenfield (BX)
120800	1/4" In-Line Connector
120802	Red Butt Connector
120902	#74B Wire Nut
120903	Closed End Connector
121014	1/4" Insulated (female) Terminal
121499	5-1/2" Wire Tie
121500	8" Harness Tie
122804	Manometer (hydro gauge) for Measuring Gas Pressure
404502	White Brush-In-Cap Bottle Touch-Up Paint
404515	Coral Blue Brush-In-Cap Bottle Touch-Up Paint
404516	Ivory Brush-In-Cap Bottle Touch-Up Paint
882458	Tumbler Puller Assembly

