

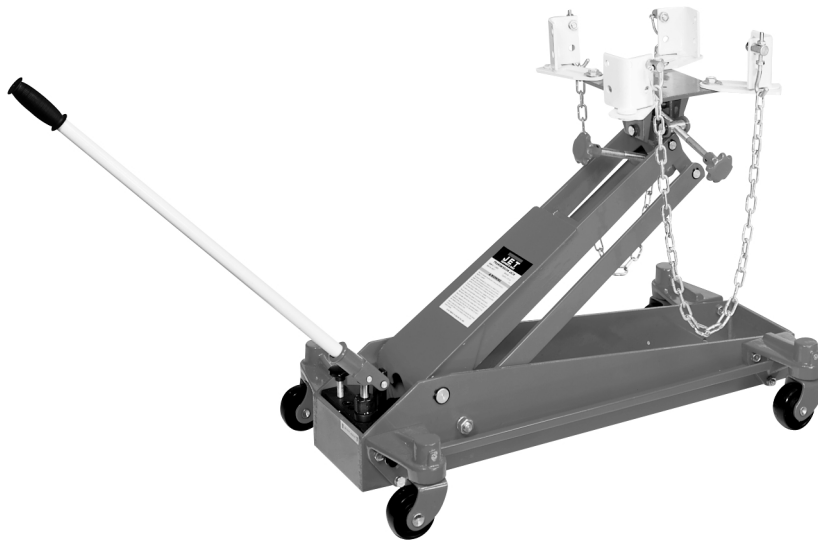

# OWNER'S MANUAL

## TJ-2000X Transmission Jack



**JET EQUIPMENT & TOOLS, INC.**

A WMH Company  
[www.jettools.com](http://www.jettools.com)

P.O. BOX 1349  
Auburn, WA 98071-1349  
e-mail [jet@jettools.com](mailto:jet@jettools.com)

Phone: 253-351-6000  
Fax: 1-800-274-6840  
**M-450077 12/01**

# Important Information

**1-YEAR  
LIMITED WARRANTY**

**JET offers a one-year limited  
warranty on this product**

## REPLACEMENT PARTS

Replacement parts for this tool are available directly from JET Equipment & Tools. To place an order, call 1-800-274-6848. Please have the following information ready:

1. Visa, MasterCard, or Discover Card number
2. Expiration date
3. Part number listed within this manual
4. Shipping address other than a Post Office box.

## REPLACEMENT PART WARRANTY

JET Equipment & Tools makes every effort to assure that parts meet high quality and durability standards and warrants to the original retail consumer/purchaser of our parts that each such part(s) to be free from defects in materials and workmanship for a period of thirty (30) days from the date of purchase.

## PROOF OF PURCHASE

Please retain your dated sales receipt as proof of purchase to validate the warranty period.

## LIMITED TOOL AND EQUIPMENT WARRANTY

JET makes every effort to assure that its products meet high quality and durability standards and warrants to the original retail consumer/purchaser of our products that each product be free from defects in materials and workmanship as follows: 1 YEAR LIMITED WARRANTY ON THIS JET PRODUCT. Warranty does not apply to defects due directly or indirectly to misuse, abuse, negligence or accidents, repairs or alterations outside our facilities or to a lack of maintenance. JET LIMITS ALL IMPLIED WARRANTIES TO THE PERIOD SPECIFIED ABOVE FROM THE DATE THE PRODUCT WAS PURCHASED AT RETAIL. EXCEPT AS STATED HEREIN, ANY IMPLIED WARRANTIES OR MERCHANTABILITY AND FITNESS ARE EXCLUDED. SOME STATES DO NOT ALLOW LIMITATIONS ON HOW LONG THE IMPLIED WARRANTY LASTS, SO THE ABOVE LIMITATION MAY NOT APPLY TO YOU. JET SHALL IN NO EVENT BE LIABLE FOR DEATH, INJURIES TO PERSONS OR PROPERTY OR FOR INCIDENTAL, CONTINGENT, SPECIAL OR CONSEQUENTIAL DAMAGES ARISING FROM THE USE OF OUR PRODUCTS. SOME STATES DO NOT ALLOW THE EXCLUSION OR LIMITATION OF INCIDENTAL OR CONSEQUENTIAL DAMAGES, SO THE ABOVE LIMITATION OR EXCLUSION MAY NOT APPLY TO YOU. To take advantage of this warranty, the product or part must be returned for examination, postage prepaid, to an authorized service station designated by our Auburn office. Proof of purchase date and an explanation of the complaint must accompany the merchandise. If our inspection discloses a defect, JET will either repair or replace the product or refund the purchase price, if we cannot readily and quickly provide a repair or replacement, if you are willing to accept such refund. JET will return repaired product or replacement at JET's expense, but if it is determined there is no defect, or that the defect resulted from causes not within the scope of JET's warranty, then the user must bear the cost of storing and returning the product. This warranty gives you specific legal rights, and you have other rights, which vary, from state to state.

**JET Equipment & Tools • P.O. Box 1349, Auburn, WA 98071-1349 • (253) 351-6000**

 **WARNING**

- Read and understand all operating instructions before use.
- The vehicle must be properly supported and blocked before starting repairs.
- Use a transmission jack of the proper size and capacity to handle the anticipated load. This jack is rated for a maximum load of 2,000 lbs. Do not overload beyond the jack's rated capacity. Overloading may cause damage to or failure of the jack.
- Keep hands, fingers, and arms away from moving parts of the jack at all times.
- Secure the load with the safety chain before lowering or moving the load.
- Lower the load slowly and avoid sudden starts or stops that may cause the load to shift.
- This jack is designed for use only on hard, level surfaces capable of sustaining the load. Use on other than hard, level surfaces can result in jack instability and possible loss of load.
- Do not use the transmission jack if under the influence of alcohol or drugs.
- This transmission jack is designed and intended for use by properly trained and experienced personnel only. If you are not familiar with the proper and safe operation of a transmission jack, do not use until proper training and knowledge have been obtained.
- The use of this jack is limited to the removal, installation, and transportation in the lowered position, of transmissions and differentials.
- Failure to comply with all of these warnings may cause loss of load, damage to the jack, and/or failure of the jack resulting in serious injury and/or property damage.

**Specifications:**

**TJ-2000X**

Stock Number.....	450077
Capacity .....	2,000 lbs.
Minimum Height .....	8-1/2"
Maximum Height .....	30-1/2"
Sideways Adjustment L/R .....	30°/30°
Forward/Backward Tilt .....	60°/17°
Saddle Size .....	7-3/4" x 7-3/4"
Base Size (LxW).....	35" x 19"
Net Weight .....	175 lbs.
Shipping Weight .....	184 lbs.

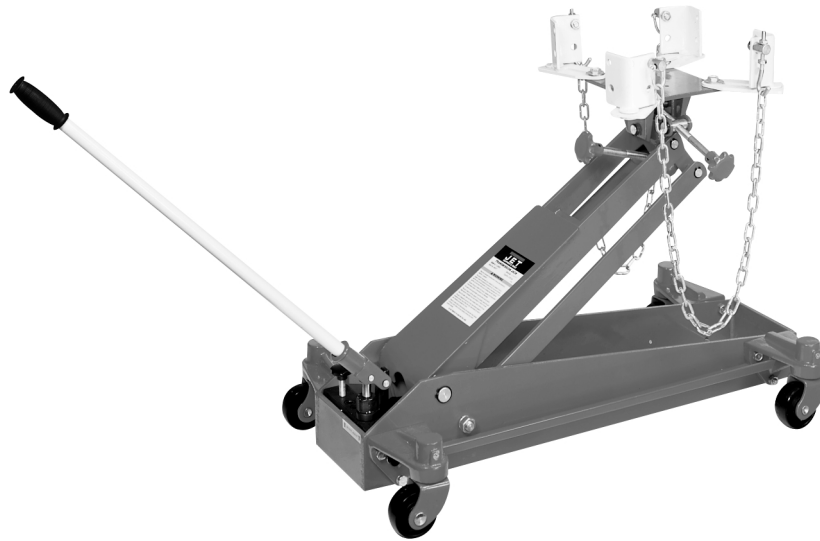

The specifications in this manual are given as general information and are not binding. JET Equipment & Tools reserves the right to effect, at any time and without prior notice, changes or alterations to parts, fittings, and accessory equipment deemed necessary for any reason whatsoever.

## **Assembly**

All numbers in parenthesis ( ) refer to the index number from the parts breakdown.

1. Mount the four angle brackets (100) to the saddle (94) using four hex cap screws (102), and four washers (101).
2. Insert four hook guides (91) into the angle bracket holes and tighten using four washers (96) and four hex nuts (95).
3. Place two chain screws (90) through hook guides and thread into chain connectors (92).
4. Thread hex nut (98) part way up the chain hook (99) followed by a washer (97). Place through hook guides and attach with washer (91), and hex nut (98). Repeat for second chain hook.
5. Screw pump handle (2) into handle socket (5).
6. Turn gear (32) clockwise to close the pump release valve. Pump handle up and down to lift the whole stroke. Turn gear (31) counter-clockwise for lowering. Test jack raising and lowering operation several times before use.

## **Operation**

All numbers in parenthesis ( ) refer to the index number from the parts breakdown.

1. Move the jack into position.
2. Turn the gear (32) clockwise fully to close the valve.
3. Move the pump lever (2) up and down to raise the saddle.
4. Adjust the angle screws (75 & 88) to align with the shape of the transmission.
5. Adjust angle brackets (100) and chain (93) to secure the transmission on the saddle. Tighten hex cap screws (102).
6. Remove the transmission from the vehicle.
7. Turn gear (32) counter-clockwise slowly to lower the saddle. Always lower the saddle slowly. Always transport the load in the lowered position with the chains securely fastened.
8. Reverse this procedure when mounting the transmission.

## **Maintenance**

1. The hydraulic cylinder assembly contains hydraulic fluid that must be kept at approximately 80% of full at all times for proper operation. To check the level and to fill, remove screw (26).
2. Fill with clean hydraulic fluid only.
3. Replace the screw.

## **Lubrication**

1. Lubricate the shaft threads of the angle screw assembly (75 & 88) with #2 tube grease when necessary.
2. Lubricate grease fitting (78) once every three months, depending on usage, with #2 tube grease.

# JET TJ-2000X Parts Breakdown

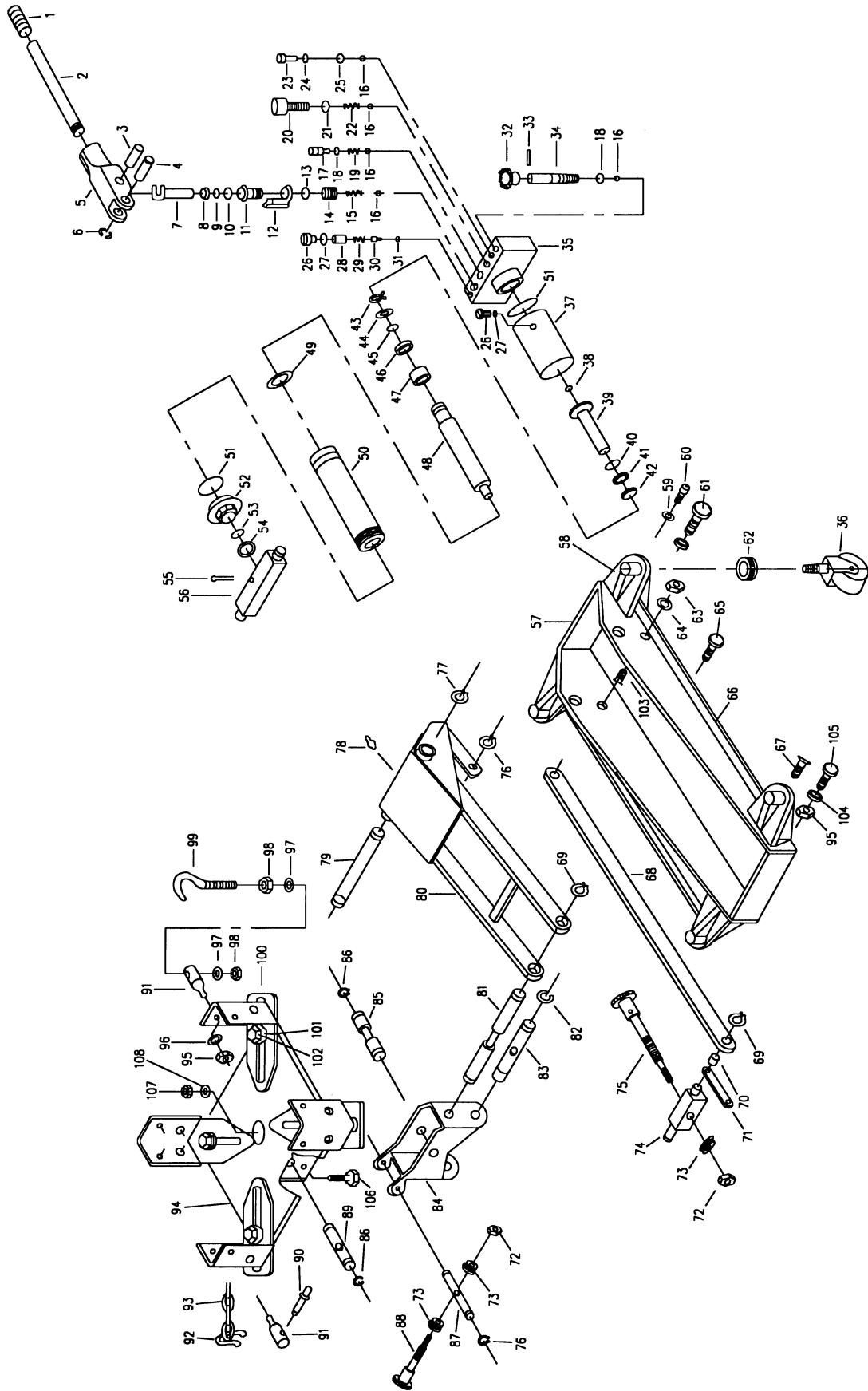

## Parts List for JET TJ-2000X

Index No.	Part No.	Description	Size	Quantity
1	TJ2000X-1	Handle Grip		1
2	TJ2000X-2	Pump Handle		1
3	TJ2000X-3	Pin	10x30	1
4	TJ2000X-4	Pin	10x30	1
5	TJ2000X-5	Socket		1
6	TJ2000X-6	Snap Ring	9	1
7	TJ2000X-7	Plunger		1
8	TJ2000X-8	Wiper *		1
9	TJ2000X-9	Back-up Ring *	Φ20x1	1
10	TJ2000X-10	O-ring *	14x2.65	1
11	TJ2000X-11	Pump		1
12	TJ2000X-12	Pump Seat		1
13	TJ2000X-13	Seal Ring	Φ22x1.5	1
14	TJ2000X-14	Screw	M10x1	1
15	TJ2000X-15	Spring	6x25	1
16	TJ2000X-16	Ball	6	5
17	TJ2000X-17	Screw	M10x1	1
18	TJ2000X-18	O-ring *	7.5x2.65	2
19	TJ2000X-19	Spring	7x19.6	1
20	TJ2000X-20	Screw	M10x20	1
21	TJ2000X-21	Seal Ring	10	1
22	TJ2000X-22	Spring	6x25	1
23	TJ2000X-23	Screw	M12x20	1
24	TJ2000X-24	Seal Ring	Φ19x2	1
25	TJ2000X-25	Ball	9	1
26	TJ2000X-26	Screw	M10x1	2
27	TJ2000X-27	O-ring *	19x2	2
28	TJ2000X-28	Screw	M10x1	1
29	TJ2000X-29	Spring	7.5x19.7	1
30	TJ2000X-30	Ball Seat		1
31	TJ2000X-31	Ball	4	1
32	TJ2000X-32	Knob		1
33	TJ2000X-33	Pin	Φ2x20	1
34	TJ2000X-34	Release Rod		1
35	TJ2000X-35	Valve Block Assembly		1
36	TJ2000X-36	Caster Assembly		4
37	TJ2000X-37	Reservoir		1
38	TJ2000X-38	O-ring *	Φ19x2.65	1
39	TJ2000X-39	Ram Assembly		1
40	TJ2000X-40	Retaining Ring *	Φ27x1.25	1
41	TJ2000X-41	O-ring *	Φ28x3	1
42	TJ2000X-42	Y-ring *	Φ30x6.3	1
43	TJ2000X-43	Retaining Ring	32	1
44	TJ2000X-44	Washer	Φ38x1.5	1
45	TJ2000X-45	O-ring *	33.2x4.6	1
46	TJ2000X-46	Retaining O-ring	42x6	1
47	TJ2000X-47	Bushing	42x20	1
48	TJ2000X-48	Piston Rod		1
49	TJ2000X-49	O-ring *	50.5x2.4	1
50	TJ2000X-50	Cylinder		1
51	TJ2000X-51	Seal Ring *	76x2	2
52	TJ2000X-52	Cylinder Nut		1
53	TJ2000X-53	O-ring *	37.5x3.55	1

Index No.	Part No.	Description	Size	Quantity
54	TJ2000X-54	Wiper *	46x6	1
55	TJ2000X-55	Split Pin	5x45	1
56	TJ2000X-56	Link Rod		1
57	TJ2000X-57	Side Plate		1
58	TJ2000X-58RF	Caster Seat Right Front		1
	TJ2000X-58RR	Caster Seat Right Rear (pump end)		1
	TJ2000X-58LR	Caster Seat Left Rear (pump end)		1
	TJ2000X-58LF	Caster Seat Left Front		1
59	TJ2000X-59	Lock Washer	12	2
60	TJ2000X-60	Screw	M12x40	2
61	TJ2000X-61	Screw	M10	6
62	TJ2000X-62	Thrust Bearing	8205	4
63	TJ2000X-63	Nut	M16	2
64	TJ2000X-64	Lock Washer	16	2
65	TJ2000X-65	Screw	M8x12	4
66	TJ2000X-66	Slot		2
67	TJ2000X-67	Screw	M6x12	4
68	TJ2000X-68	Long Link Rod		2
69	TJ2000X-69	Snap Ring	16	4
70	TJ2000X-70	Spacer	22x15	2
71	TJ2000X-71	Short Link Rod		2
72	TJ2000X-72	Nut	M10	2
73	TJ2000X-73	Thrust Bearing	8100	3
74	TJ2000X-74	Guide Axle		1
75	TJ2000X-75	Screw Assy	M14X221	1
76	TJ2000X-76	Snap Ring	20	4
77	TJ2000X-77	Snap Ring	25	2
78	TJ2000X-78	Grease Fitting		1
79	TJ2000X-79	Shaft Arm		1
80	TJ2000X-80	Lifting Arm Assembly		1
81	TJ2000X-81	Axle		1
82	TJ2000X-82	Retaining Ring	18	2
83	TJ2000X-83	Axle	18x88	1
84	TJ2000X-84	Saddle Base		1
85	TJ2000X-85	Axle		1
86	TJ2000X-86	Snap Ring	18	4
87	TJ2000X-87	Axle		1
88	TJ2000X-88	Screw Assy		1
89	TJ2000X-89	Axle		1
90	TJ2000X-90	Chain Screw		2
91	TJ2000X-91	Hook Guide		4
92	TJ2000X-92	Chain Connector		2
93	TJ2000X-93	Chain		2
94	TJ2000X-94	Saddle		1
95	TJ2000X-95	Hex Nut	M10	10
96	TJ2000X-96	Washer	10	4
97	TJ2000X-97	Washer	8	8
98	TJ2000X-98	Nut	M8	8
99	TJ2000X-99	Chain Hook		1
100	TJ2000X-100	Containing Angle		4
101	TJ2000X-101	Washer	12	4
102	TJ2000X-102	Screw	M12x20	4
103	TJ2000X-103	Bolt	Φ22x40	2
104	TJ2000X-104	Lock Washer	10	12
105	TJ2000X-105	Screw	M10x35	6
106	TJ2000X-106	Hex Cap Screw		1



<b>Index No.</b>	<b>Part No.</b>	<b>Description</b>	<b>Size</b>	<b>Quantity</b>
107	TJ2000X-107	Hex Nut		1
108	TJ2000X-108	Washer		1
	TJ2000X-109	Piston Packing Set (incls. 40-48)		
	TJ2000X-PA	Pump Assembly (incls. 7-35, 37-54)		
	TJ2000X-PRK	Pump Repair Kit (incls. 8-10, 18, 27, 38, 40-42, 45, 49, 51, 53, 54)		
	* indicates included in pump repair kit			



## TEST CERTIFICATE

COMMODITY	Transmission Jack
MODEL	TJ-2000X
SERIAL NO.	
CAPACITY	2,000 lbs
TEST LOAD	lbs
DATE OF INSPECTION	
JUDGEMENT	<b>PASSED</b>
INSPECTOR	

**JET EQUIPMENT & TOOLS, INC.**  
A WMH Company  
www.jettools.com

P.O. BOX 1349  
Auburn, WA 98071-1349  
e-mail jet@jettools.com

Phone:253-351-6000  
Fax: 1-800-274-6840