

INSTALLATION

1. GAS CONNECTION *(Gas dryers only)*

- a. Remove the shipping cap from gas pipe at the rear of the dryer.

NOTE: DO NOT connect the dryer to L.P. gas service without converting the gas valve. An L.P. conversion kit must be installed by a qualified gas technician.

- b. Connect a 1/2 inch (1.27 cm) I.D. semi-rigid or approved pipe from gas supply line to the 3/8 inch (0.96 cm) pipe located on the back of the dryer. Use a 1/2 inch to 3/8 inch (1.27 cm to 0.96 cm) reducer for a connection. Apply an approved thread sealer that is resistant to the corrosive action of liquefied gases on all pipe connections.
- c. Open the shutoff valve in the gas supply line.
- d. Test all connections by brushing on a soapy water solution. **NEVER TEST FOR GAS LEAKS WITH AN OPEN FLAME.**

2. Connect the exhaust duct to outside exhaust system. Use duct tape to seal all joints.

3. With the dryer in its final position, adjust one or more of the legs until the dryer is resting solid on all four legs. Place a level on top of the dryer. **THE DRYER MUST BE LEVEL AND RESTING SOLID ON ALL FOUR LEGS.**

4. Plug the power cord into a grounded outlet. **NOTE:** Check to ensure the power is off at circuit breaker/fuse box before plugging the power cord into the outlet.

5. Turn on the power at the circuit breaker/fuse box.

CAUTION Before operating the dryer, make sure the dryer area is clear and free from combustible materials, gasoline, and other flammable vapors. Also see that nothing (such as boxes, clothing, etc.) obstructs the flow of combustion and ventilation air.

6. Run the dryer through a cycle check for proper operation. **NOTE:** On gas dryers, before the burner will light, it is necessary for the gas line to be bled of air. If the burner does not light within 45 seconds the first time the dryer is turned on, the safety switch will shut the burner off. If this happens, turn the timer to "OFF" and wait 5 minutes before making another attempt to light.

7. Place these instructions in a location near the dryer for future reference.

NOTE: A wiring diagram is located inside the dryer.

REPLACEMENT PARTS

If replacement parts are needed for your dryer, contact the source where you purchased your dryer, or call Sears Parts and Service Toll Free Number 1-800-4-MY-HOME (1-800-469-4663).

CAUTION Label all wires prior to disconnection when servicing controls. Wiring errors can cause improper and dangerous operation. Verify proper operation after servicing.

WARNING Destroy the carton and plastic bags after the dryer is unpacked. Children might use them for play. Cartons covered with rugs, bedspreads, or plastic sheets can become airtight chambers causing suffocation. Place all materials in a garbage container or make materials inaccessible to children.

WARNING The instructions in this manual and all other literature included with this dryer are not meant to cover every possible condition and situation that may occur. Good safe practice and caution **MUST** be applied when installing, operating and maintaining any appliance.

Lint Blade Retaining Pin Location and Orientation

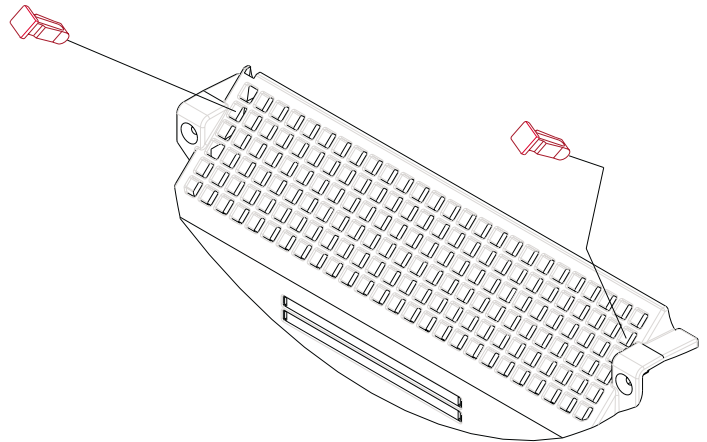

Install the pins after the lint blade is installed.

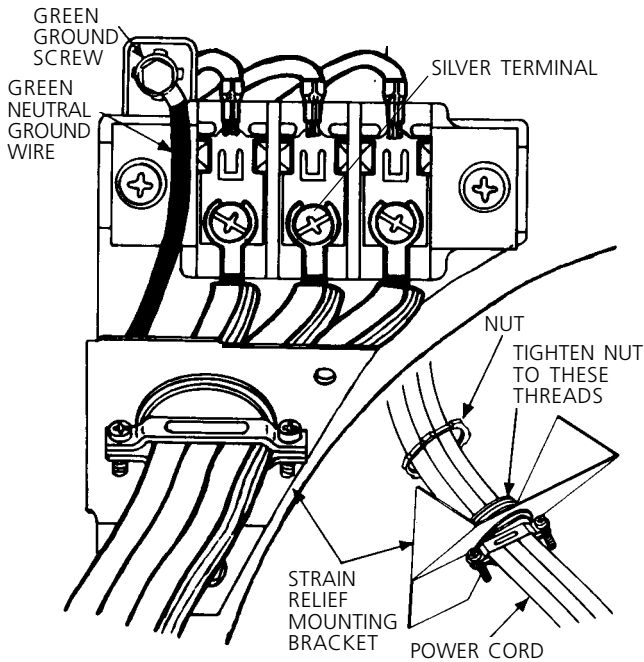

ELECTRICAL CONNECTIONS FOR 3-WIRE SYSTEM

ELECTRIC Dryer

1. Remove the screws securing the terminal block access cover and the strain relief mounting bracket located on the back of the dryer upper corner.
 2. Install a U.L. listed strain relief into the power cord entry hole of the mounting bracket. Finger tighten the nut only at this time.
 3. Thread a U.L. listed 30 amp. power cord, NEMA 10-30 Type SRDT, through the strain relief.
 4. Attach the power cord neutral (center wire) conductor to the silver colored center terminal on the terminal block. Tighten the screw securely.
 5. Attach the remaining two power cord outer conductors to the outer brass colored terminals on the terminal block. Tighten both screws securely.
- ⚠ WARNING** Do not make a sharp bend or crimp wiring/conductor at connections.
6. Reattach the strain relief mounting bracket to the back of the dryer with two screws. Tighten screws securely.
 7. Tighten the screws securing the cord restraint firmly against the power cord.
 8. Tighten the strain relief nut securely so that the strain relief does not turn.
 9. Reinstall the terminal block cover.

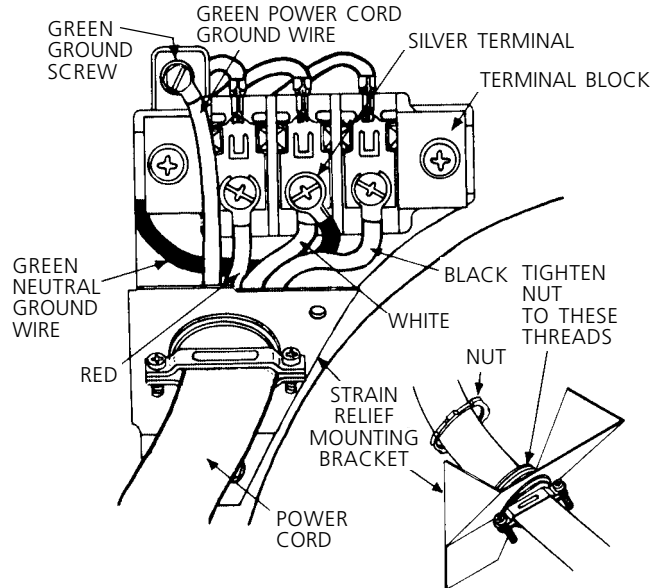

ELECTRICAL CONNECTIONS FOR 4-WIRE SYSTEM

ELECTRIC Dryer

1. Remove the screws securing the terminal block access cover and the strain relief mounting bracket located on the back of the dryer upper corner.
2. Install a U.L. listed strain relief in the entry hole of the mounting bracket. Finger tighten the nut only at this time.
3. Remove the green neutral ground wire from the green ground screw located above the terminal block.

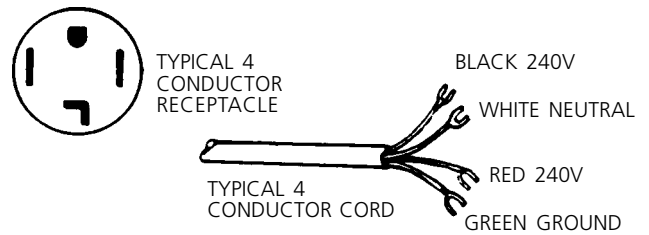

30 AMP NEMA 14-30 TYPE SRDT OR ST

4. Thread a U.L. listed 30 amp power cord, NEMA 14-30 type ST or SRDT through the strain relief.
 5. Attach the green power cord ground wire to the cabinet with the green ground screw.
 6. Attach the white (neutral) power cord conductor from the power cord and the green ground wire from the dryer harness (removed from the ground screw in step 3) to the silver-colored center terminal on the terminal block. Tighten the screw securely.
 7. Attach the red and black power cord conductors to the outer brass-colored terminals on the terminal block.
- ⚠ WARNING** Do not make a sharp bend or crimp wiring/conductor at the connections.
8. Tighten the screws securing the cord restraint firmly against the power cord.
 9. Tighten the strain relief nut securely so the strain relief does not turn.
 10. Reinstall the terminal block access cover.

ELECTRICAL INSTALLATION

Before proceeding with electrical installation, install the dryer's coin-metering system (when used) in accordance with the separate instructions provided with the meter.

ALL ELECTRIC Dryers

⚠ WARNING The following are specific requirements for proper and safe electrical installation of your dryer. Failure to follow these instructions can create electrical shock and/or a fire hazard.

⚠ This appliance **MUST** be properly grounded. Electrical shock can result if the dryer is not properly grounded. Follow the instructions in this manual for proper grounding.

⚠ Do not use an extension cord with this dryer. Some extension cords are not designed to withstand the amounts of electrical current this dryer utilizes and can melt, creating electrical shock and/or fire hazard. Locate the dryer within reach of the receptacle for the length power cord to be purchased, allowing some slack in the cord. Refer to the pre-installation requirements in this manual for the proper power cord to be purchased.

⚠ A U.L. listed strain relief must be installed onto power cord. If the strain relief is not attached, the cord can be pulled out of the dryer and can be cut by any movement of the cord, resulting in electrical shock.

⚠ Do not use an aluminum wired receptacle with a copper wired power cord and plug (or vice versa). A chemical reaction occurs between copper and aluminum and can cause electrical shorts. **The proper wiring and receptacle is a copper wired power cord with a copper wired receptacle.**

NOTE: Dryers operating on 208 volt power supply will have longer drying times than operating on 240 volt power supply.

GROUNDING REQUIREMENTS

ELECTRIC Dryer

⚠ DANGER Improper connection of the equipment grounding conductor can result in a risk of electrical shock. Check with a licensed electrician if you are in doubt as to whether the appliance is properly grounded.

For a grounded, cord-connected dryer:

1. The dryer **MUST** be grounded. In the event of a malfunction or breakdown, grounding will reduce the risk of electrical shock by a path of least resistance for electrical current.
2. If your dryer is equipped with a power supply cord having an equipment-grounding conductor and a grounding plug, the plug **MUST** be plugged into an appropriate, copper wired receptacle that is properly installed and grounded in accordance with all local codes and ordinances. If in doubt, call a licensed electrician.

For a permanently connected dryer:

1. The dryer **MUST** be connected to a grounded metal, permanent wiring system; or an equipment grounding conductor must be run with the circuit conductors and connected to the equipment-grounding terminal or lead on the appliance.

ALL GAS Dryers

This dryer is equipped with a three-prong (grounding) plug for your protection against shock hazard and should be plugged directly into a properly grounded three-prong receptacle. Do not cut or remove the grounding prong from this plug.

ROUGH-IN DIMENSIONS

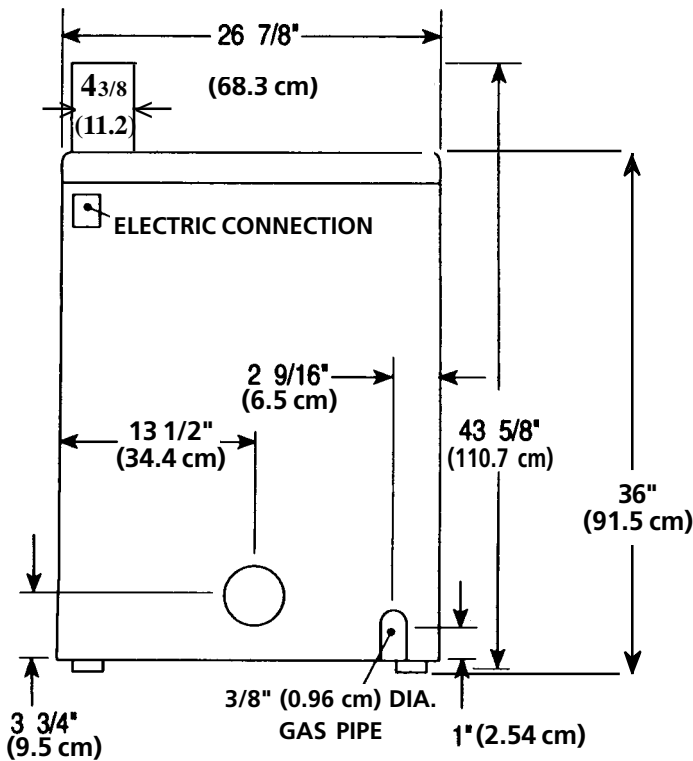

REAR VIEW

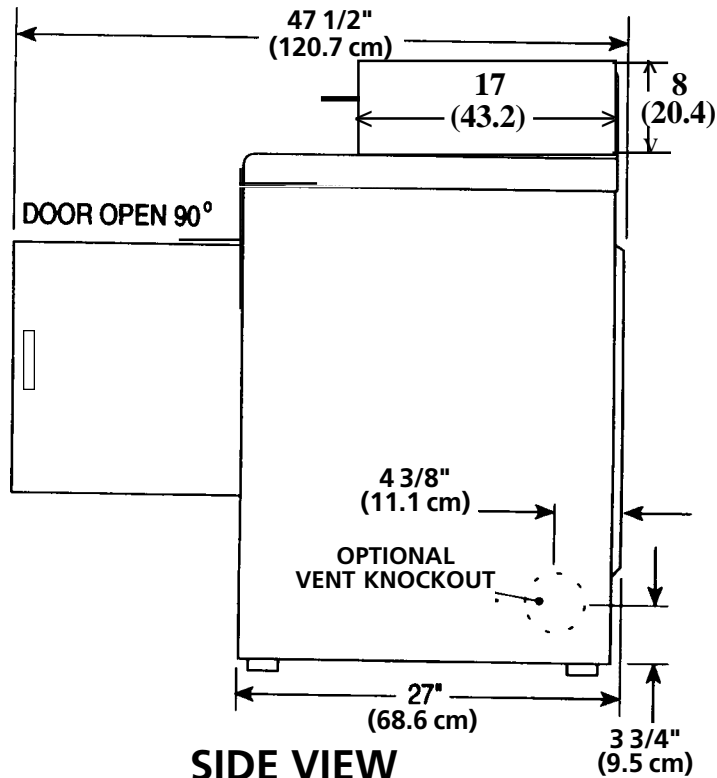

SIDE VIEW

UNPACKING

- Using the four shipping carton corner posts (two on each side), carefully lay the dryer on its left side and remove foam shipping base.

CAUTION To prevent damage, do not use the control panel or coin meter housing as a means to pick up or move the dryer.

NOTE: On under counter model clothes dryers, the top panel may be removed for installation.

- Return the dryer to an upright position.

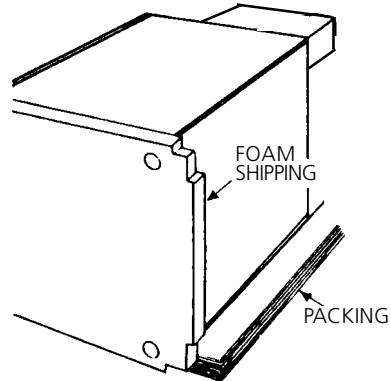

REVERSING DOOR SWING

Your dryer is designed so the door swing may be reversed at any time without additional parts. Conversion is accomplished by transferring hinges to the opposite side of the cabinet.

To change the direction of the door opening:

- Open the dryer door. Remove the four hinge hole plugs from the left side of the door opening. Place nearby for future installation. **NOTE:** You may need a plastic knife to help pull out the plugs. Be careful not to scratch the paint.
- Remove the four screws that secure the door hinges to the dryer front panel (see below). **NOTE:** Remove one screw from each of the two hinges first. Hold the door firmly before removing the last two screws.
- Rotate the door 180° and reinstall the door hinges to the dryer front panel with the four screws.
- Install the four hinge hole plugs in the open screw holes on the right side of the door opening.

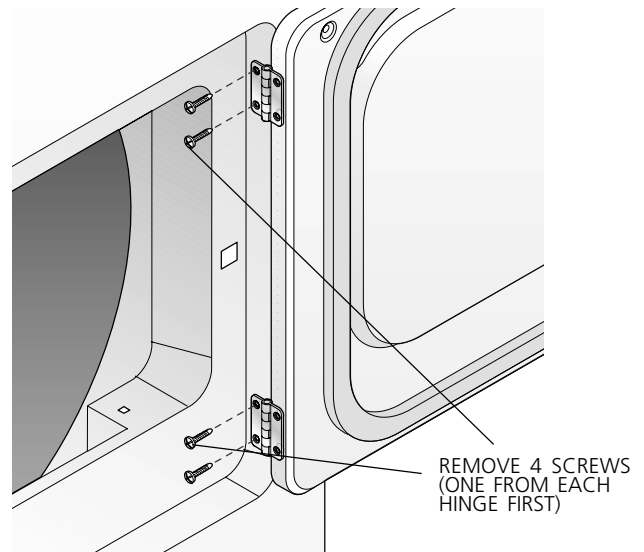

LOCATION OF YOUR DRYER

DO NOT INSTALL YOUR DRYER:

1. In an area exposed to dripping water or outside weather conditions.
2. In an area where it will come in contact with curtains, drapes, or anything that will obstruct the flow of combustion and ventilation air.
3. On carpet. Floor **MUST** be solid with a maximum slope of 1 inch (2.54 cm).

INSTALLATION IN RECESS OR CLOSET

1. A dryer installed in a bedroom, bathroom, recess or closet, **MUST** be exhausted outdoors.
2. No other fuel burning appliance shall be installed in the same closet as the Gas dryer.
3. Your dryer needs the space around it for proper ventilation.

DO NOT INSTALL YOUR DRYER IN A CLOSET WITH A SOLID DOOR.

4. A minimum of 120 square inches (774.2 square cm) of opening, equally divided at the top and bottom of the door, is required. Air openings are required to be unobstructed when a door is installed. A louvered door with equivalent air openings for the full length of the door is acceptable.

MINIMUM INSTALLATION CLEARANCES (Inches)



	FRONT	SIDES	REAR	TOP
Alcove	0 (0 cm)	0 (0 cm)	0 (0 cm)	15 (38.1 cm)
Closet	1 (2.54 cm)	0 (0 cm)	0 (0 cm)	15 (38.1 cm)

Closet door ventilation required: 2 louvered openings each 60 square inches (387 square centimeters) — 3 inches (7.6 cm) from bottom and top of door.

THIS DRYER MUST BE EXHAUSTED OUTDOORS.

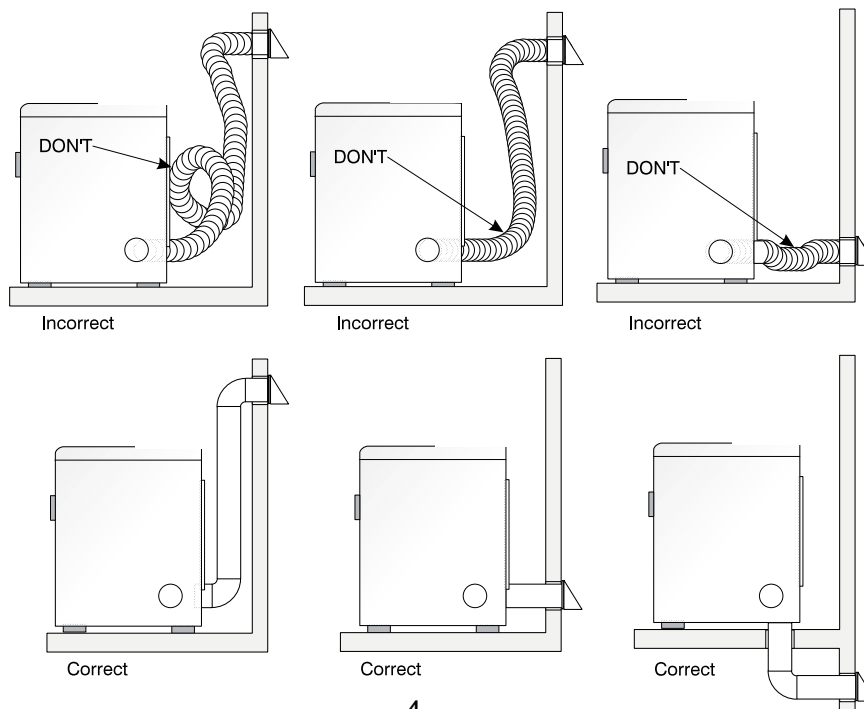
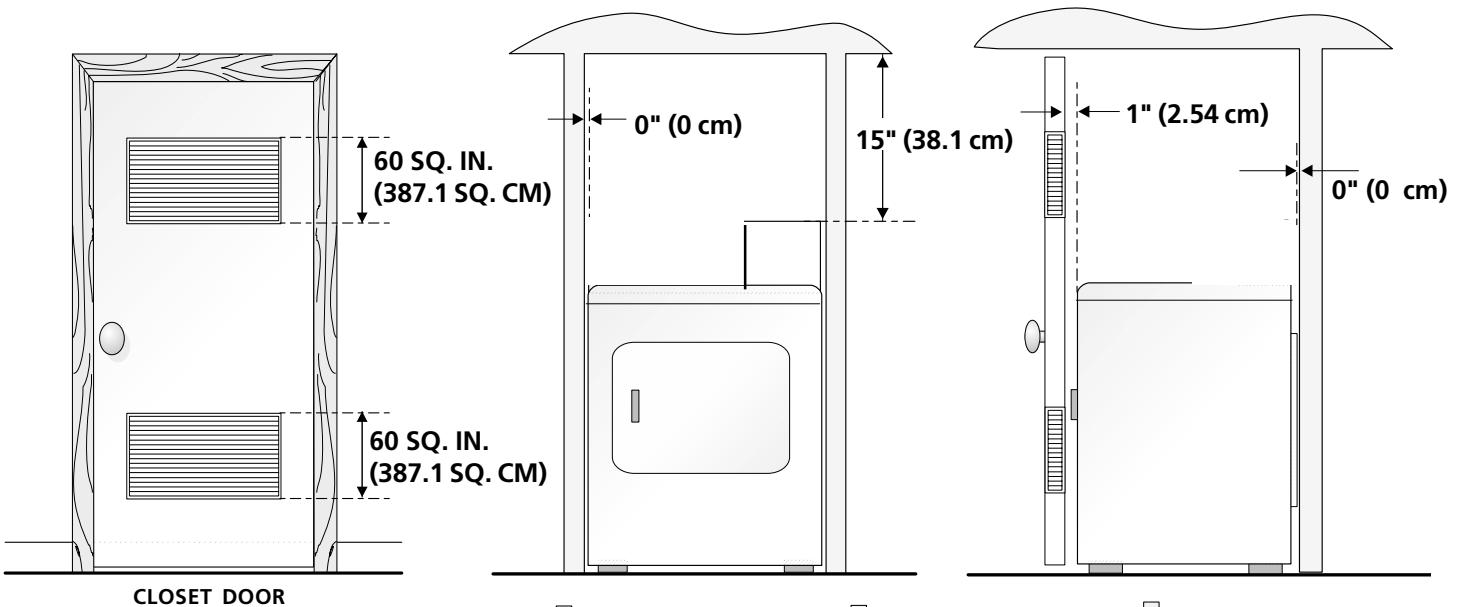
5. The following illustrations show minimum clearance dimensions for proper operation in a recess or closet installation.

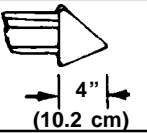

MAXIMUM LENGTH of 4" (10.2 cm) Dia. Rigid Metal Duct			
VENT HOOD TYPE (Preferred)			
Number of 90° Turns		Louvered	
	4" (10.2 cm)		2½" (6.35 cm)
0	60 ft. (18.28 m)		48 ft. (14.63 m)
1	52 ft. (15.84 m)		40 ft. (12.19 m)
2	44 ft. (13.41 m)		32 ft. (9.75 m)
3	32 ft. (9.75 m)		24 ft. (7.31 m)
4	28 ft. (8.53 m)		16 ft. (4.87 m)

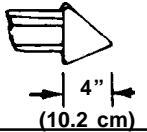
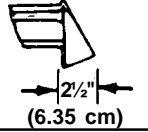
MAXIMUM LENGTH of 4" (10.2 cm) Dia. Flexible Metal Duct			
VENT HOOD TYPE (Preferred)			
Number of 90° Turns		Louvered	
	4" (10.2 cm)		2½" (6.35 cm)
0	30 ft. (9.14 m)		18 ft. (5.49 m)
1	22 ft. (6.71 m)		14 ft. (4.27 m)
2	14 ft. (4.27 m)		10 ft. (3.05 m)
3	NOT RECOMMENDED		

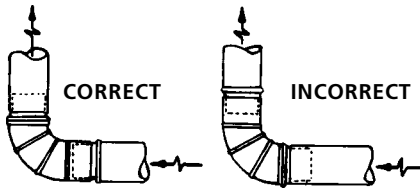

INSTALL MALE FITTINGS IN CORRECT DIRECTION

In installations where the exhaust system is not described in the charts, the following method must be used to determine if the exhaust system is acceptable:

1. Connect an inclined or digital manometer between the dryer and the point the exhaust connects to the dryer.
2. Set the dryer timer and temperature to air fluff (cool down) and start the dryer.
3. Read the measurement on the manometer.
4. The system back pressure **MUST NOT** be higher than 0.75 inches of water column. If the system back pressure is less than 0.75 inches of water column, the system is acceptable. If the manometer reading is higher than 0.75 inches of water column, the system is too restrictive and the installation is unacceptable.

Although vertical orientation of the exhaust system is acceptable, certain extenuating circumstances could affect the performance of the dryer:

- Only the rigid metal duct work should be used.

- Venting vertical through a roof may expose the exhaust system to down drafts causing an increase in vent restriction.
- Running the exhaust system through an uninsulated area may cause condensation and faster accumulation of lint.
- Compression or crimping of the exhaust system will cause an increase in vent restriction.

The exhaust system should be inspected and cleaned a minimum of **every 6 months** with normal usage. The more the dryer is used, the more often you should check the exhaust system and vent hood for proper operation.

EXHAUST DIRECTION

All dryers shipped from the factory are set up for rear exhausting. However, on electric dryers, exhausting can be to the right or left side of the cabinet or the bottom of the dryer. On gas dryers, exhausting can be to the right side of the cabinet or the bottom of the dryer. Directional exhausting can be accomplished by installing Exhaust Kit, P/N 131456800, available through your parts distributor. Follow the instructions supplied with the kit.

EXHAUST DUCT LOCATING DIMENSIONS

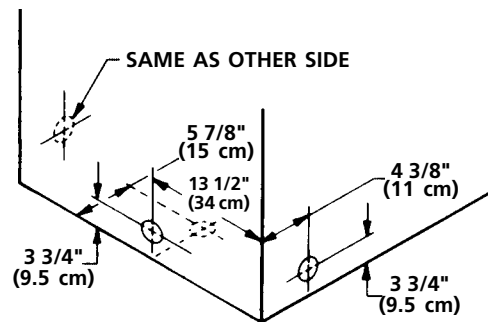

GAS SUPPLY REQUIREMENTS

! WARNING Replace copper connecting pipe that is not plastic-coated. Stainless steel or plastic-coated brass **MUST** be used.

1. Installation **MUST** conform with local codes, or in the absence of local codes, with the National Fuel Gas Code, ANSI Z223.1 (latest edition).
2. The gas supply line should be of 1/2 inch (1.27 cm) pipe.
3. If codes allow, flexible metal tubing may be used to connect your dryer to the gas supply line. The tubing **MUST** be constructed of stainless steel or plastic-coated brass.
4. The gas supply line **MUST** have an individual shutoff valve.
5. A 1/8 inch (0.32 cm) N.P.T. plugged tapping, accessible for test gauge connection, **MUST** be installed immediately upstream of the gas supply connection to the dryer.
6. The dryer **MUST** be disconnected from the gas supply piping system during any pressure testing of the gas supply piping system at test pressures in excess of 1/2 psig (3.45 kPa).
7. The dryer **MUST** be isolated from the gas supply piping system during any pressure testing of the gas supply piping system at test pressures equal to or less than 1/2 psig (3.45 kPa).

PRE-INSTALLATION REQUIREMENTS

Tools and Materials Required for Installation:

1. Phillips head screwdriver.
2. Channel-lock adjustable pliers.
3. Carpenter's level.
4. Flat or straight blade screwdriver.
5. Duct tape.
6. Rigid or flexible metal 4 inch (10.2 cm) duct.
7. Vent hood.
8. Pipe thread sealer (Gas).
9. Plastic knife.

ELECTRICAL REQUIREMENTS

***ELECTRIC* Dryer**

CIRCUIT - Individual 30 amp. branch circuit fused with 30 amp. minimum time delay fuses or circuit breakers.

POWER SUPPLY - 3 wire, 240 volt, single phase, 60 Hz, Alternating Current.

POWER SUPPLY CORD KIT - The dryer **MUST** employ a 3-conductor power supply cord NEMA 10-30 type SRDT rated at 240 volt AC minimum, 30 amp., with 3 open end spade lug connectors with upturned ends or closed loop connectors and marked for use with clothes dryers, **OR** a 4-conductor power supply cord NEMA 14-30 type SRDT or ST (as required) rated at 240 volt AC minimum, 30 amp., with 4 open end spade lug connectors with upturned ends or closed loop connectors and marked for use with clothes dryers. See ELECTRICAL CONNECTIONS FOR A 4-WIRE SYSTEM.

OUTLET RECEPTACLE - NEMA 10-30R or 14-30R receptacle to be located so the power supply cord is accessible when the dryer is in the installed position.

Typical 3-wire installation

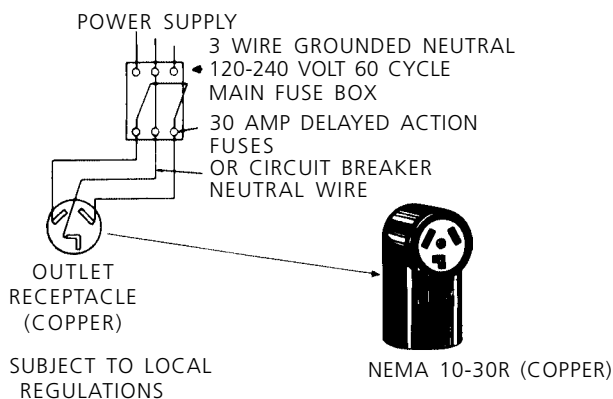

***GAS* Dryer**

CIRCUIT - Individual 15 amp. branch circuit fused with a 15 amp. maximum time delay fuse or circuit breaker.

POWER SUPPLY - 3 wire, 120 volt single phase, 60 Hz, Alternating Current.

POWER SUPPLY CORD - The dryer is equipped with a 120 volt 3-wire power cord.

NOTE: Do not under any circumstances remove grounding prong from plug.

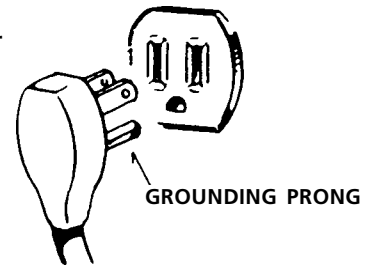

EXHAUST SYSTEM REQUIREMENTS

Use only 4 inch (10.2 cm) diameter (minimum) rigid or flexible metal duct and approved vent hood which has a swing-out damper(s) that open when the dryer is in operation. When the dryer stops, the dampers automatically close to prevent drafts and the entrance of insects and rodents. To avoid restricting the outlet, maintain a minimum of 12 inches (30.5 cm) clearance between the vent hood and the ground or any other obstruction.

! WARNING The following are specific requirements for proper and safe operation of your dryer. Failure to follow these instructions can create excessive drying times and fire hazards.

! Do not use plastic flexible duct to exhaust the dryer. Excessive lint can build up inside exhaust system and create a fire hazard and restrict air flow. Restricted air flow will increase dryer times. If your present system is made up of plastic duct or metal foil duct, replace it with a rigid or flexible metal duct. **Ensure the present duct is free of any lint prior to installing dryer duct.**

! If the dryer is not exhausted outdoors, some fine lint will be expelled into the laundry area. An accumulation of lint in any area of the building can create a health and fire hazard. **The dryer exhaust system MUST be exhausted to the outside of the building!**

! Do not allow combustible materials (for example: clothing, draperies/curtains, paper) to come in contact with exhaust system. The dryer **MUST NOT** be exhausted into a chimney, a wall, a ceiling, or any concealed space of a building which can accumulate lint, resulting in a fire hazard.

! Exceeding the length of duct pipe or number of elbows allowed in the "MAXIMUM LENGTH" charts can cause an accumulation of lint in the exhaust system. Plugging the system could create a fire hazard, as well as increase drying times.

! Do not screen the exhaust ends of the vent system, nor use any screws or rivets to assemble the exhaust system. Lint can become caught in the screen, on the screws or rivets, clogging the duct work and creating a fire hazard as well as increasing drying times. Use an approved vent hood to terminate the duct outdoors, and seal all joints with duct tape. All male duct pipe fittings **MUST** be installed downstream with the flow of air.

! WARNING Explosion hazard. Do not install the dryer where gasoline or other flammables are kept or stored. If the dryer is installed in a garage, it must be a minimum of 18 inches



Installation Instructions

Gas & Electric Dryer

Before beginning installation, carefully read these instructions. This will simplify the installation and ensure the dryer is installed correctly and safely. Leave these instructions near the Dryer after installation for future reference.

NOTE: The electrical service to the Dryer must conform with local codes and ordinances and the latest edition of the National Electrical Code, ANSI/NFPA 70.

NOTE: The gas service to the Dryer must conform with local codes and ordinances and the latest edition of the National Fuel Gas Code ANSI Z223.1.

Contents

SUBJECT	PAGE
Pre-Installation Requirements	2
Electrical Requirements	2
Exhaust System Requirements	2-3
Gas Supply Requirements	3
Location of Your Dryer	4
Rough-In Dimensions	5
Unpacking	5
Reversing Door Swing	5
Electrical Installation	6
Grounding Requirements	6
Electrical Connections—3-wire	7
Electrical Connections—4-wire	7
Installation	8
Replacement Parts	8
Lint Blade Retaining Pin Location	8

**Sears, Roebuck and Co.,
Hoffman Estates, IL 60179 U.S.A.**

⚠ WARNING For your safety the information in this manual must be followed to minimize the risk of fire or explosion or to prevent property damage, personal injury or loss of life.

- Do not store or use gasoline or other flammable vapors and liquid in the vicinity of this or any other machine.

- WHAT TO DO IF YOU SMELL GAS

- Do not try to light any machine.
- Do not touch any electrical switch; do not use any phone in your building.
- Clear the room, building or area of all occupants.
- Immediately call your gas supplier from a neighbor's phone. Follow the gas supplier's instructions.
- If you cannot reach your gas supplier, call the fire department.

Installation and service must be performed by a qualified installer, service agency or the gas supplier.

!CAUTION: DISCONNECT ELECTRIC CURRENT BEFORE SERVICING. LABEL ALL WIRES PRIOR TO DISCONNECTION WHEN SERVICING CONTROLS. WIRING ERRORS CAN CAUSE IMPROPER AND DANGEROUS OPERATION. VERIFY PROPER OPERATION AFTER SERVICING.

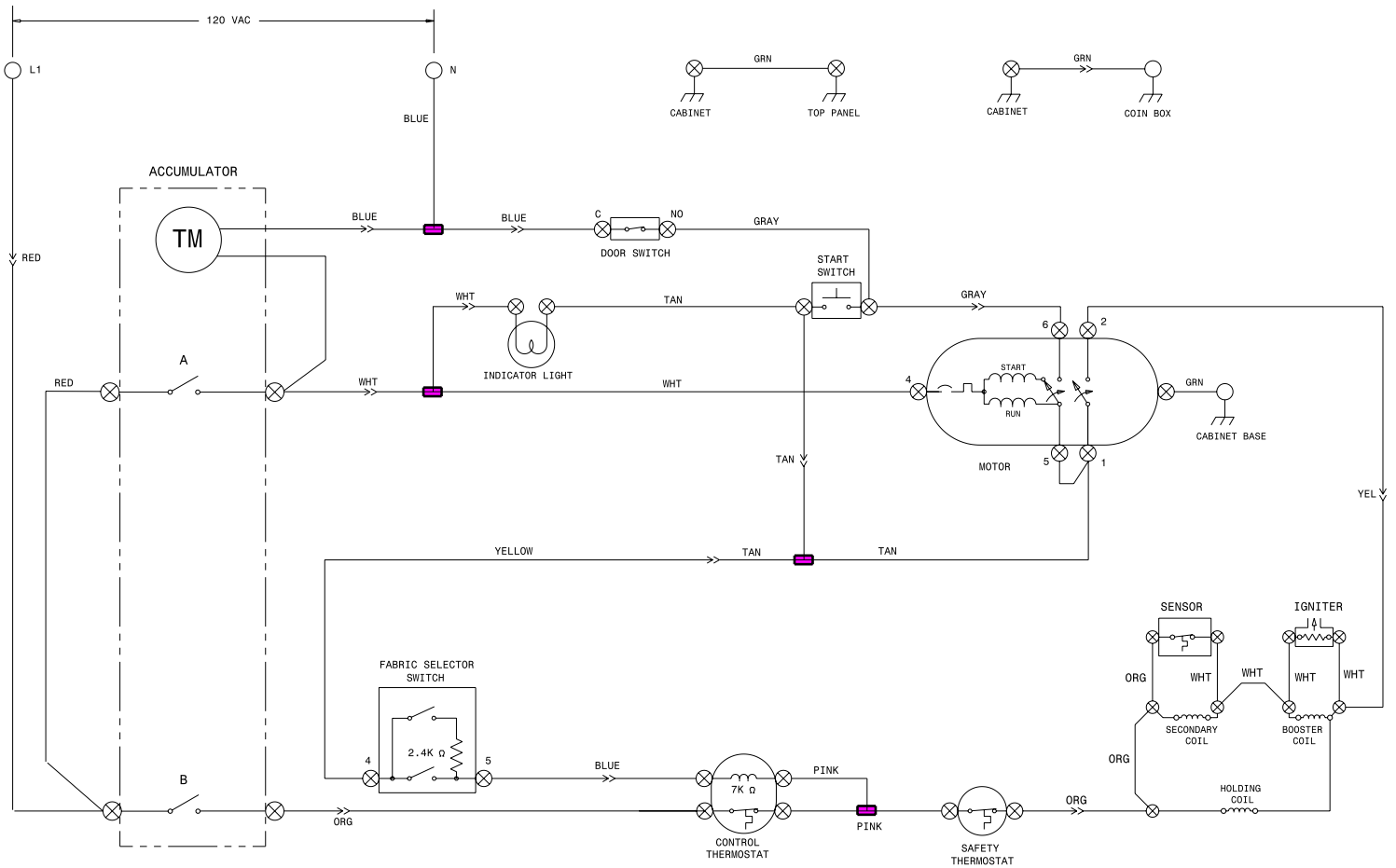

WIRING CODES	
	QUICK DISCONNECT TERMINAL
	CONNECTION
	NO CONNECTION
	MOTOR SWITCH
	SPLICE
	MOTOR PROTECTOR
	CHASSIS (CABINET) GROUND
	SCREW TERMINAL
	HARNES CONNECTOR TERMINAL
	INSULATED TERMINAL

FABRIC SELECTOR SWITCH	
FUNCTION	RESISTANCE Ω
HIGH	∞
MEDIUM	$2.4K \pm 5\%$
LOW	10 MAX

- NOTES:
1. ALL WIRING MUST CONFORM TO LOCAL ELECTRICAL CODES.
 2. CONNECT DRYER TO A 15 AMP INDIVIDUAL BRANCH CIRCUIT.
 3. SHOWN IN OFF POSITION, DOOR SWITCH CLOSED, MOTOR AT REST, THERMOSTAT CLOSED AND FABRIC SELECTOR SWITCH AT REGULAR.

1 ACCUMULATION

DRIVE MOTOR	_____
HEATER	_____





The Service Side of Sears.™

**REPAIR
PARTS
LIST**

417.64182300

**To Call Toll Free
For Parts:
1-800-366-PART
(1-800-366-7278)**

**For Service:
1-800-4-MY-HOME®
(1-800-469-4663)**



SEARS

Dryer

When placing a part order, give the complete model number shown on the serial plate located on the inside of the dryer door.

All repair parts listed are available for immediate purchase or special order when you visit your nearest Sears Service Center. To order parts by phone, call the toll free parts number listed to the left.

When requesting service or ordering parts, always provide the following information:

- **Product Type**
- **Part Number**
- **Model Number**
- **Part Description**

417.64182300

CABINET/DRUM

CAUTION: Use the Kenmore part number to order parts, not the illustration number.

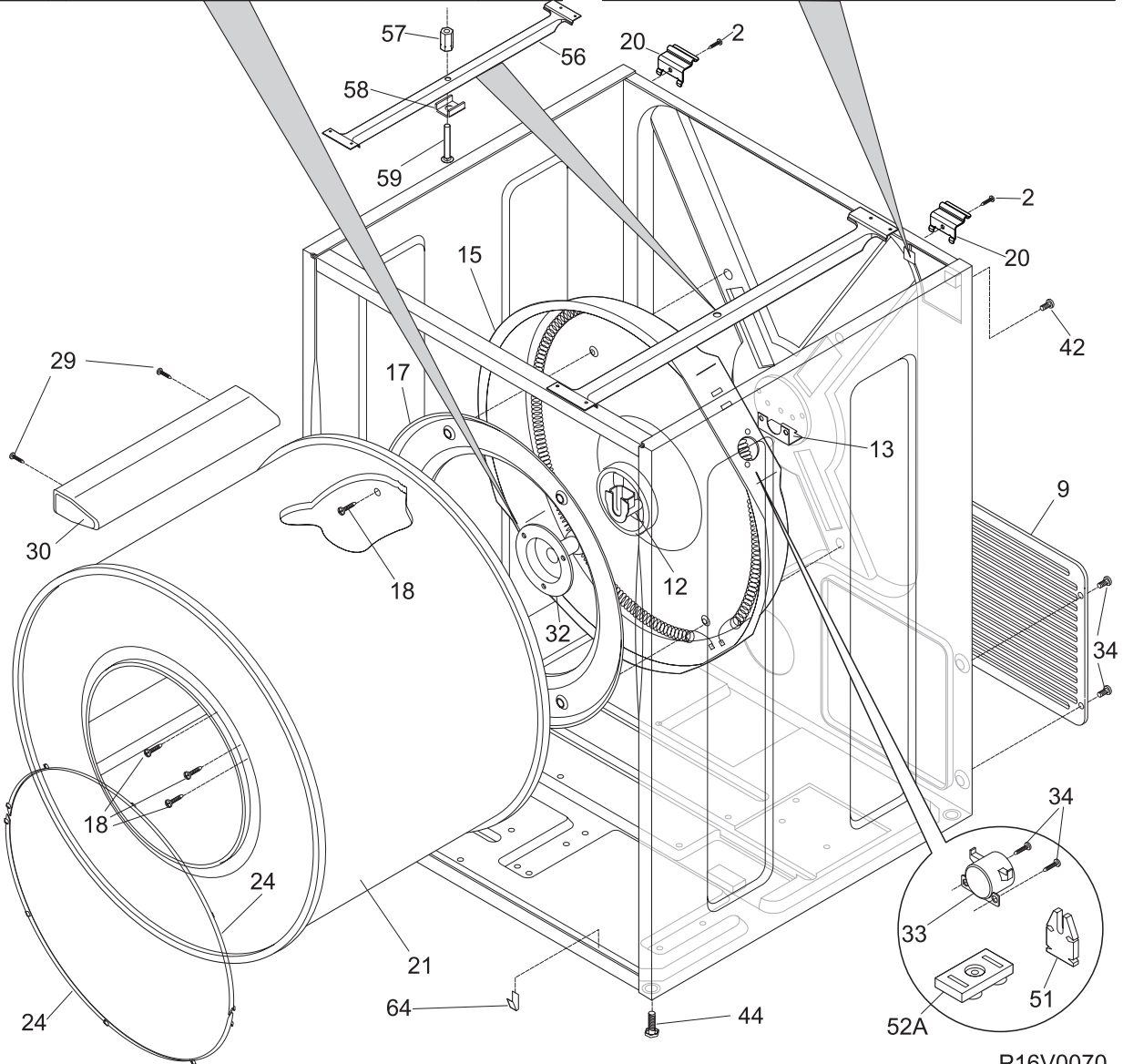
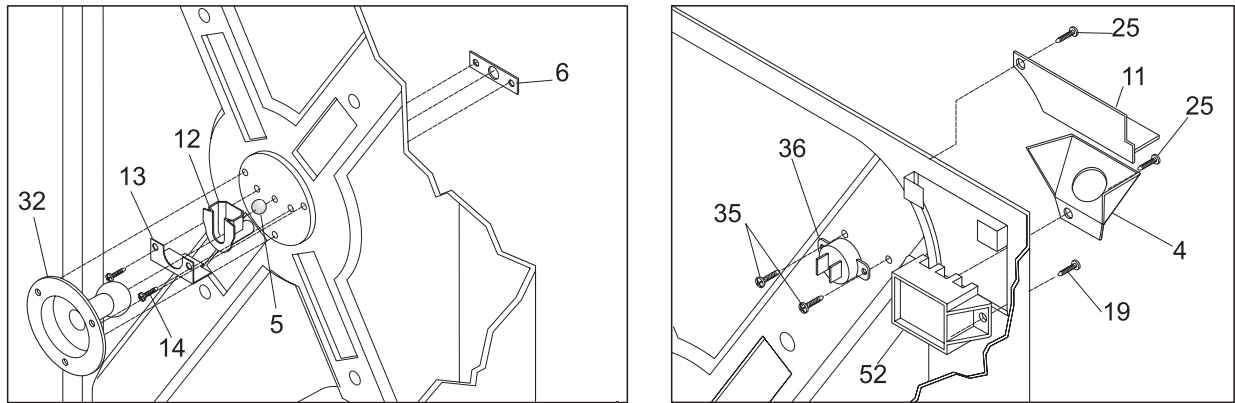

P16V0070

417.64182300

CABINET/DRUM

CAUTION: Use the Kenmore part number to order parts, not the illustration number.

POS. NO	PART NO	DESCRIPTION
2	131962400	Screw,tamper resist ,10-16 x .375
4	131785200	Bracket,elec power cord ,knock out
5	5303281019	Ball
6	5303281020	Clip,ball ,steel ,flat nut
9	131793201	Panel,access ,rear
11	5303211428	Cover,terminal block
12	131825900	Bearing,drum support
13	131724300	Bracket,bearing support
14	131205400	Screw,bracket mtg. ,10-16B x 1.375 ,cr/sq drive
15 #	131553900	Heater Assy,w/housing/felt
17	3204254	Baffle,heater shield
18	131477000	Screw,10-16AB x 0.375
19	131205300	Screw,10-16 x 0.750
20	131469100	Bracket,hinge ,rear ,top panel mtg.
21	134122572	Drum,dryer ,painted ,service kit
24	131963900	Glide,drum
25	5303015671	Screw,hex washer head ,8-18 x 0 .375 ,cup point
29	131382300	Screw,quadrex head ,10-14 x 1.00 ,vane mtg.,special
30	5303201200	Vane,straight
32	131777700	Shaft,drum support ,ballhitch
32*	5303307893	Lubricant,high temp
33 #	3204267	Thermostat,safety
34	131243700	Screw,pan head ,8-18AB x 0.375 ,cr/sq drive
35	131892100	Screw,6-20B x 0.230
36 #	134120900	Thermal Limiter
42	134154100	Screw,hex washer head ,10-32 x 0.375 ,ground
44	134158000	Screw,leveling leg
51	131472100	Insulator,heater housing
52 #	134101400	Terminal Block,main
* #	134310100	Wiring Harness,main
52A#	3202786	Terminal Block,heater housing
56	131949300	Brace
57	131981900	Spacer,security
58	131949400	Retainer
59	131686601	Bolt,carriage ,3/8-16 x 3.50
64	131704600	Clip
* #	5303281153	Rear Bearing Kit,includes 5,6 ,12,13,14,18,32

417.64182300

FRONT PANEL/LINT FILTER

CAUTION: Use the Kenmore part number to order parts, not the illustration number.

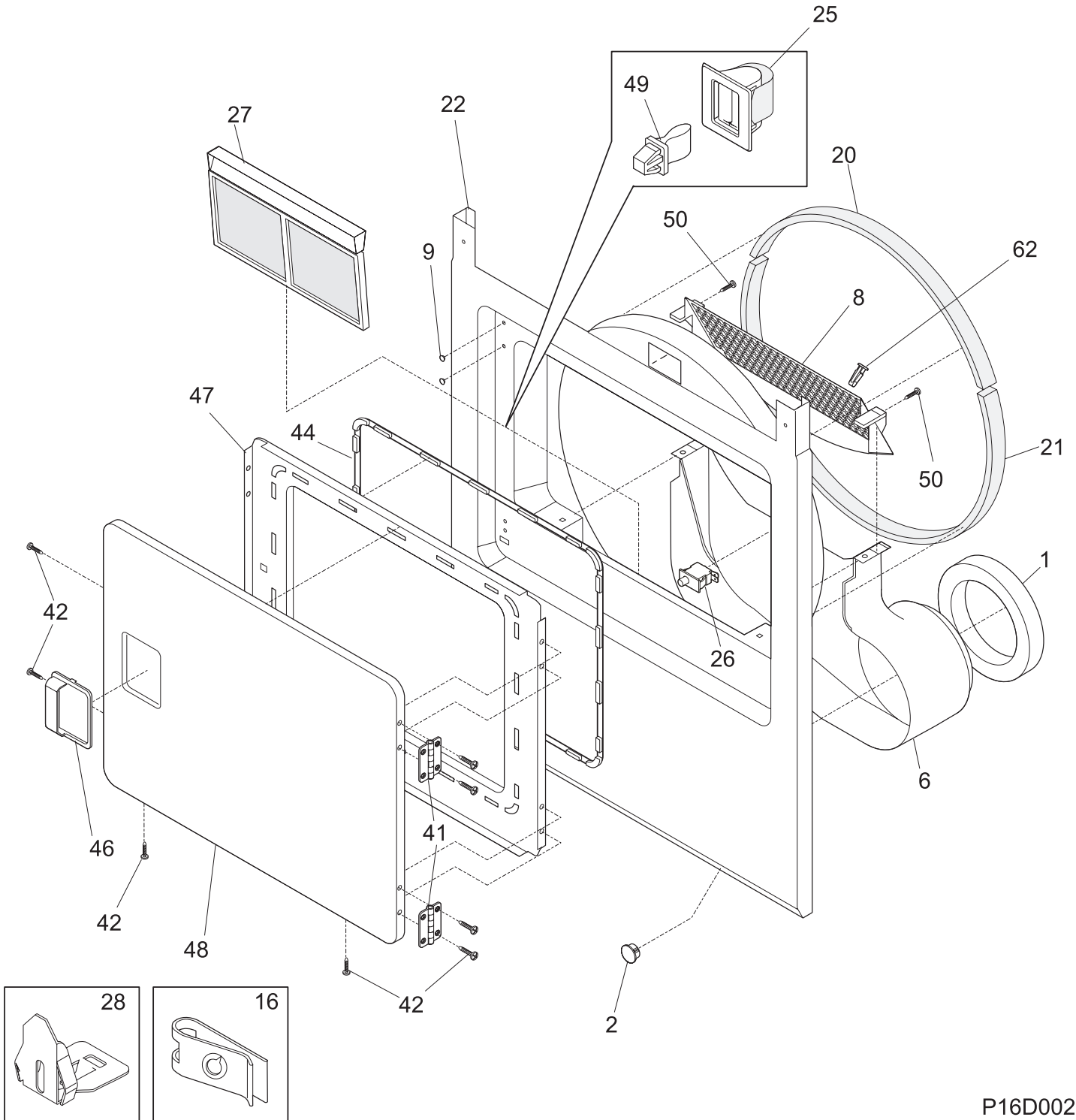

P16D0027

417.64182300

FRONT PANEL/LINT FILTER

CAUTION: Use the Kenmore part number to order parts, not the illustration number.

POS. NO	PART NO	DESCRIPTION
1	134063300	Seal,air duct
2	131397000	Plug,dome ,white
6	131621902	Duct,air
8	131622202	Cover,lint housing
9	134146500	Plug,hinge hole ,white
16	131063700	Clip,wiring
20	134036400	Seal,felt ,upper
20*	5308027429	Adhesive,high temp
21	134134700	Seal,felt ,lower
22	131845902	Panel,front ,white ,with lamp hole
22*	131870700	Plug,light hole
22*	131474700	Insulation
25	131658800	Door Catch
26 #	131843100	Switch,door ,w/o drum light
27	131450300	Trap,lint blade assy
28	5303281074	Clip,guide ,(3)
41	131627500	Hinge,door
42	131209600	Screw,flat head ,8-18AB x 0.44 ,cr/sq drive
44	131129900	Gasket,door seal
46	131644700	Handle,door ,white
47	131844104	Panel,inner door ,white
48	131789303	Panel,outer door ,white
49	5303211430	Door Strike
50	131303300	Screw,pan head ,10-16AB x 0.500 ,locking
62	131872000	Pin,retainer ,lint blade

417.64182300

CONTROLS/TOP PANEL

CAUTION: Use the Kenmore part number to order parts, not the illustration number.

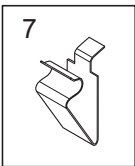
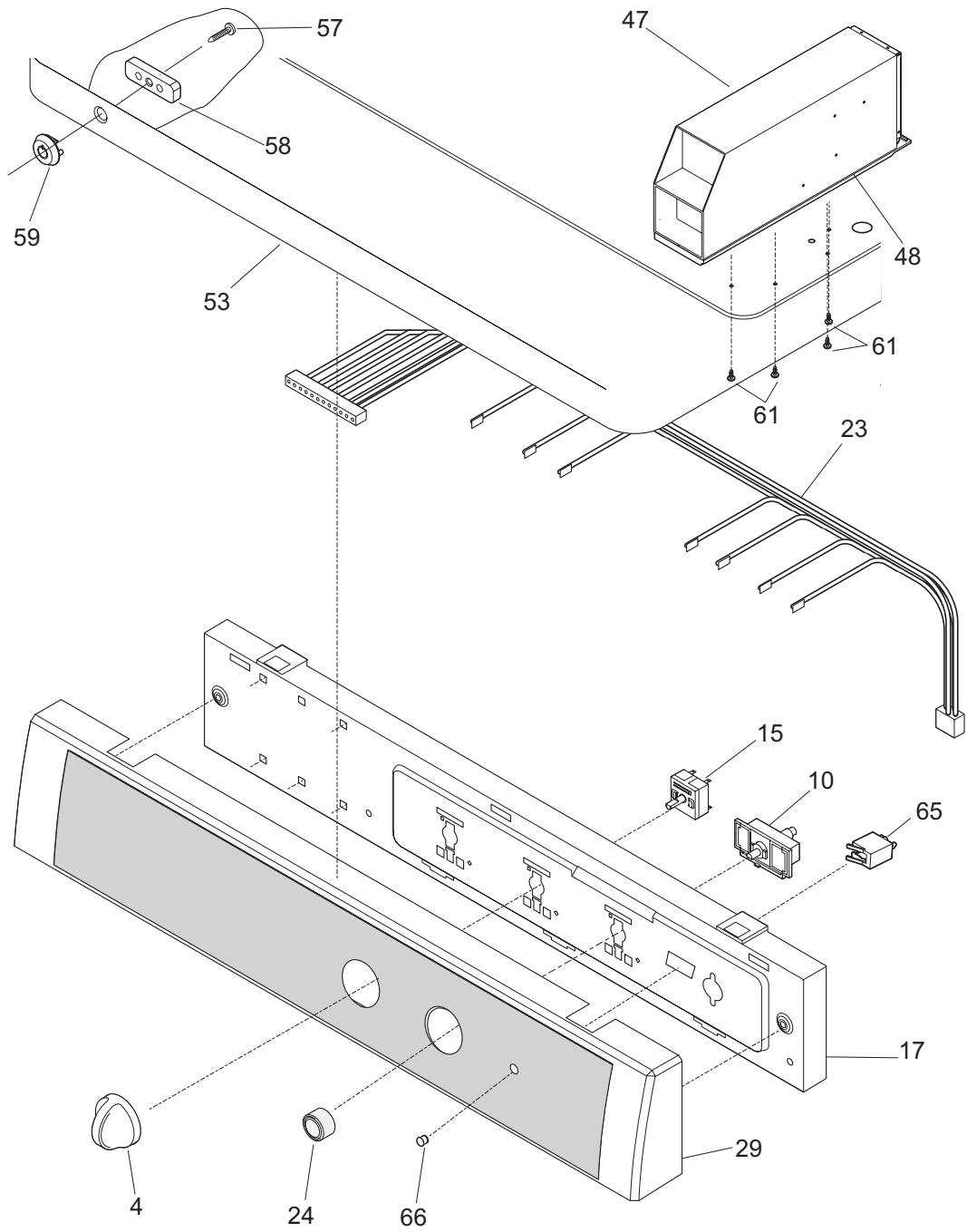

P16C0217

417.64182300

CONTROLS/TOP PANEL

CAUTION: Use the Kenmore part number to order parts, not the illustration number.

POS. NO	PART NO	DESCRIPTION
4	131689300	Knob,rotary ,white & gray
7	3205821	Clip,top-to-front
10 #	131469000	Switch,push/start
15 #	131259200	Switch,temperature
17	134064501	Bracket,control mtg.
23	134028500	Wiring Harness,controls
* #	134310100	Wiring Harness,main
24	131970200	Button,push/start ,white
29	131666969	Console,frame ,w/trim & tape
47 #	134274000	Meter Case,assy
47*	5304435395	Mounting Hardware,meter case ,security
48	134028000	Gasket,meter housing
53	134086822	Panel,dryer top ,white ,coin-op
57	3205253	Screw,pan head ,6-20B X 0.375
58	131863800	Retainer,button plug
59	131863700	Plug,button
61	131901700	Screw,mcn point ,1/4-20 ,(4)
65 #	131724700	Light,pilot
66	131724800	Lens,pilot light
*	134313400	Instructions,installation
*	134308200	Wiring Diagram

417.64182300

MOTOR

CAUTION: Use the Kenmore part number to order parts, not the illustration number.

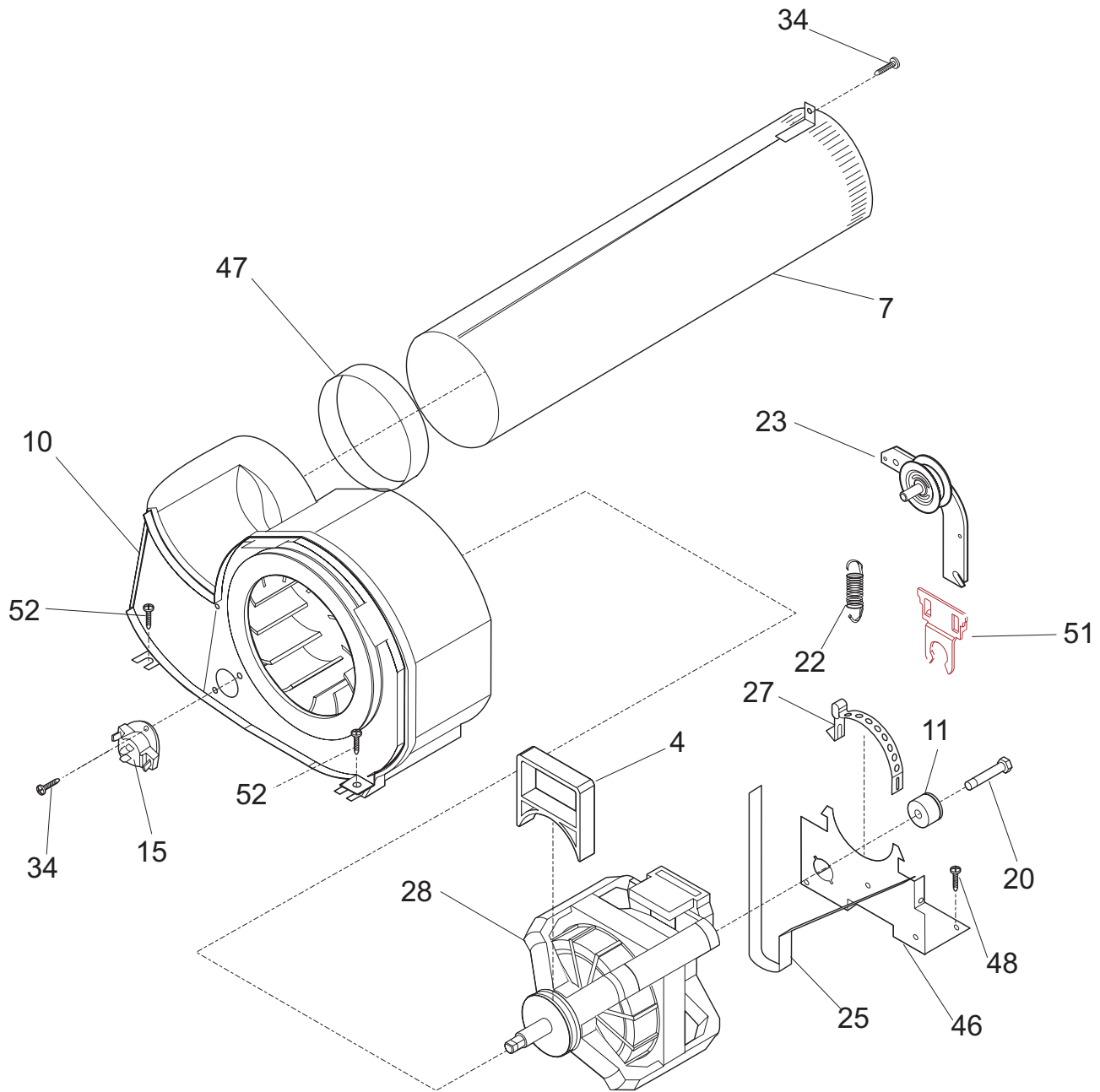

417.64182300

MOTOR

CAUTION: Use the Kenmore part number to order parts, not the illustration number.

POS. NO	PART NO	DESCRIPTION
4	131435200	Lock,blower housing
7	131451600	Tube,exhaust ,rear ,w/mtg bracket
7*	131456800	Tube,exhaust ,side/bottom ,Optional Kit
10 #	131775600	Housing,blower assy ,cover & wheel
11	131749800	Spacer,idler
15 #	131298300	Thermostat,temp control
20	131017900	Screw,hex head ,1/4-20T x 1.25 ,spacer mtg.,thread cutting
22	131601000	Spring,idler arm
23	131863002	Idler Arm Assy,w/pulley & clip
25 #	134163400	Belt,dryer
27	134242400	Clamp,motor mtg.
28 #	131560100	Motor,main drive ,w/pulley
34	131243700	Screw,pan head ,8-18AB x 0.375 ,cr/sq drive
46	134203400	Bracket,motor mtg
47	131633300	Seal,exhaust tube
48	131168200	Screw,pan head ,8-18B x 0.31
51	134032800	Clip,retainer ,idler arm assy
52	131303100	Screw,hex washer head ,10-16AB x 0.625

WIRING DIAGRAM

CAUTION: Use the Kenmore part number to order parts, not the illustration number.

!CAUTION: DISCONNECT ELECTRIC CURRENT BEFORE SERVICING. LABEL ALL WIRES PRIOR TO DISCONNECTION WHEN SERVICING CONTROLS. WIRING ERRORS CAN CAUSE IMPROPER AND DANGEROUS OPERATION. VERIFY PROPER OPERATION AFTER SERVICING.

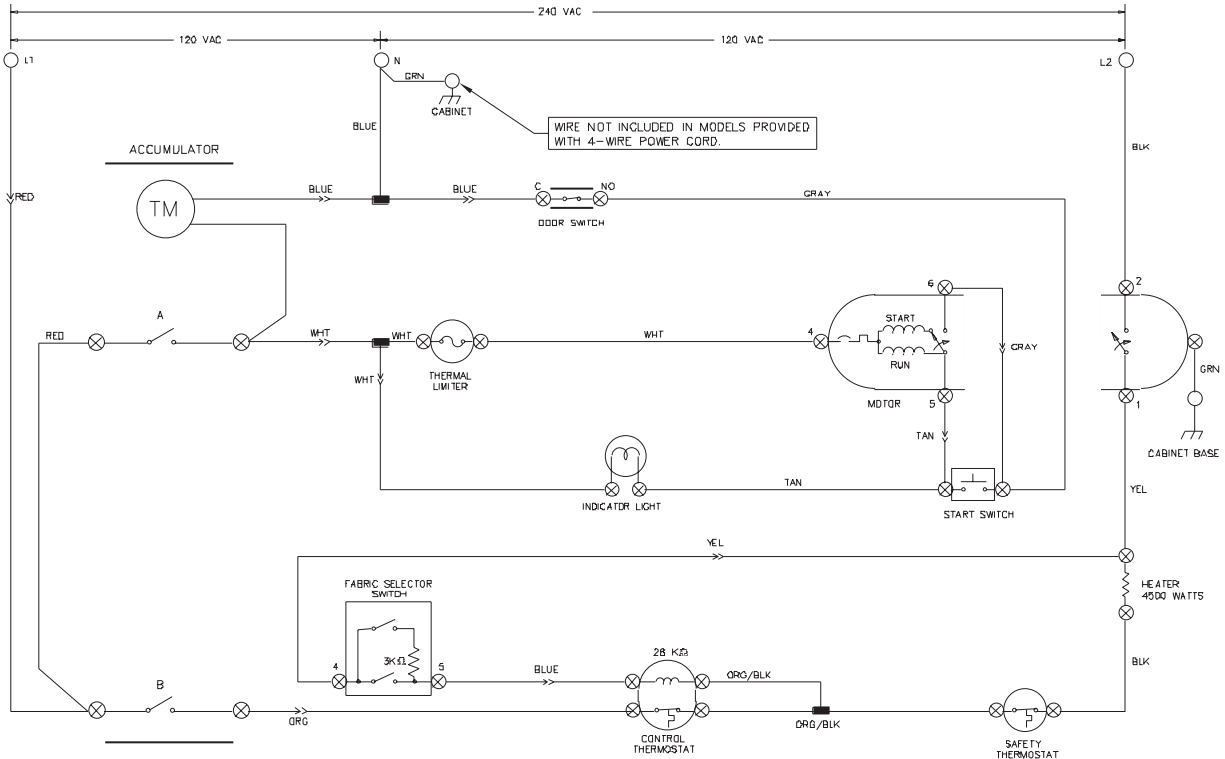

WIRING CODES	
⊗	QUICK DISCONNECT TERMINAL CONNECTION
+	NO CONNECTION
⊕	MOTOR SWITCH
— —	SPLICE
— —	MOTOR PROTECTOR
⌋	CHASSIS (CABINET) GROUND
○	SCREW TERMINAL
→	HARNES CONNECTOR TERMINAL
⊗	INSULATED TERMINAL

FABRIC SELECTOR SWITCH	
FUNCTION	RESISTANCE Ω
HIGH	∞
MEDIUM	3K ±5%
LOW	10 MAX

- NOTES:
 1. ALL WIRING MUST CONFORM TO LOCAL ELECTRICAL CODES.
 2. CONNECT DRYER TO A 30 AMP INDIVIDUAL BRANCH CIRCUIT.
 3. SHOWN IN OFF POSITION, DOOR SWITCH CLOSED, MOTOR AT REST, THERMOSTAT CLOSED AND FABRIC SELECTOR SWITCH AT REGULAR.

1 ACCUMULATION

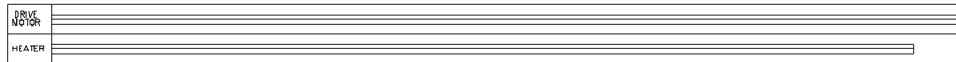

Get it fixed, at your home or ours!

Your Home

For repair—in **your home**—of **all** major brand appliances, lawn and garden equipment, or heating and cooling systems, **no matter who made it, no matter who sold it!**

For the replacement parts, accessories and owner's manuals that you need to do-it-yourself.

For Sears professional installation of home appliances and items like garage door openers and water heaters.

1-800-4-MY-HOME® (1-800-469-4663)

Call anytime, day or night (U.S.A. and Canada)

www.sears.com www.sears.ca

Our Home

For repair of carry-in items like vacuums, lawn equipment, and electronics, call or go on-line for the location of your nearest

Sears Parts & Repair Center.

1-800-488-1222

Call anytime, day or night (U.S.A. only)

www.sears.com

To purchase a protection agreement (U.S.A.) or maintenance agreement (Canada) on a product serviced by Sears:

1-800-827-6655 (U.S.A.)

1-800-361-6665 (Canada)

Para pedir servicio de reparación a domicilio, y para ordenar piezas:

1-888-SU-HOGARSM

(1-888-784-6427)

Au Canada pour service en français:

1-800-LE-FOYER^{MC}

(1-800-533-6937)

www.sears.ca

SEARS