Contents

Description	Page
Introduction	3
Warranty	3
Health and Safety	4
Machine Card	4
General Safety Instructions	5
Refrigerant R134a Safety Data	6
Installation	8
Installation – Electrical	9
Installation – Mechanical	9
Installation Recommendations	9
Commissioning	10
Start-Up Procedure	10
Description of Operation	10
Schematic Flow Diagram	11
General Arrangement Drawings	12
Technical Description of Components	17
Technical Data Tables	18
Electrical Description	20
Wiring Diagrams	22
Control of Refrigerant Discharge	26
Log Book	26
Routine Maintenance	27
Fault Finding	28
Notes	31

Information

This product has been manufactured for:

**Denco Limited
Dolphin House
Moreton Business Park
Moreton-on-Lugg
Hereford
HR4 8DS**

**Telephone: +44 (0) 1432 277277
Facsimile: +44 (0) 1432 377364**

Important

The refrigerant available on the C series of Compressed Air Dryers is **Refrigerant R134a or Refrigerant R407C**. It is imperative that refrigerants are not mixed. A label is fixed to each compressor, which identifies the refrigerant being used within the unit, and that refrigerant **ONLY** should be used in the dryer. R134a & R407C are ozone benign refrigerants and meet the requirements of the revised "Montreal Protocol". These refrigerants require the use of ESTER oil within the system and not MINERAL oil as used with R22 systems, and therefore again these oils must **NOT** be mixed.

Introduction

The Denco C series of Compressed Air Dryers are used to remove entrained moisture from compressed air supply systems and thus protect the various components and are designed such that routine maintenance is kept to a minimum.

Most parts are field replaceable but should major maintenance or repair be required please refer to Denco Limited or an authorised distributor.

*NOTE: This manual applies **ONLY** to the **C series of Compressed Air Dryers**. For actual model refer to serial plate fitted to the unit. For other ranges refer to the respective manuals.*

Warning

These Dryers are only designed for use with compressed air at or below the design maximum pressure (see Technical Data sheet(s) for maximum working pressures applicable). These Dryers must **NOT** be used for drying any other gases or fluids at other pressures. Operation of these Dryers using compressed air of a greater temperature than that specified will cause excessively high pressures in the refrigeration system, which may be dangerous.

The air supplied to the dryer must be free of any corrosive or combustible gases or impurities.

Warranty

The warranty will only be considered valid if the equipment supplied is installed, commissioned and maintained in accordance with the instructions issued by Denco Limited. Furthermore the Company will not accept any liability whatsoever should the Dryer be installed incorrectly or operated outside its stated design duties and operating conditions or improper use be made of the equipment.

Health and Safety

Due regard shall be given to observing safe procedures when working with or on the equipment. It is the responsibility of the Installer / Operator / Customer to ensure that the "Health and Safety at Work Act (1974)" and Normal Safe Working Procedures are adhered to at all times.

With reference to the "Control of Substances Hazardous to Health Regulations 1988 (COSHH)" the following paragraphs have been extracted from Denco's letter responding to information requested

"However, certain substances contained within materials used in the manufacture of our units could be hazardous when released, if the unit is misused, abused or maintained by unskilled labour.

Fumes would be released if pipework or slab foam insulation (Armaflex or similar), electrical insulation or vinyl coatings were exposed to naked flame. It will be, therefore, that no naked flame should be applied to any of the above mentioned substances, nor to print, rubber or plastic parts.

Light oil is applied to some bare metal parts as a protective coating and this could cause dermatic reaction to sensitive skin.

Refrigerants contain hydrofluorocarbons (HFC's). Glycol/water mix is used during manufacture but drained before delivery. The quantities in use are minimal but care should be taken in disposal.

We trust that this information is sufficient but should you require further information regarding our products or maintenance service, please contact our sales department."

Machine Card

In order to comply with BS EN 378-2:2000 "Refrigeration Systems and Heat Pumps – Safety and Environmental Requirements", an adequately protected card shall be situated near the operating site and must be clearly readable. The card shall at least contain the following information:

- 1) Name, address and telephone number of the installer, his service department, or the person responsible for the refrigeration and the addresses and telephone numbers of the Fire Department, Police, Hospitals and Burns Centres
- 2) The refrigerant is R134a or R407C (refer to Technical Data Table)
- 3) To shut down the Compressed Air Dryer in an emergency, switch off the unit using the ON/OFF isolating switch on the front panel. The mains supply to the Dryer should be isolated at the mains isolator.
- 4) Maximum Allowable Pressures
Compressed Air 13 barg
- 5) Flammability Limits in Air
NONE

General Safety Instructions

IMPORTANT: THE FOLLOWING SAFETY PRECAUTIONS MUST BE READ AND UNDERSTOOD BEFORE REPAIR OR MAINTENANCE WORK IS ATTEMPTED.

General

- Beware of the following danger areas within the dryer :
 - a) Any rotating components (fan etc.)
 - b) Sharp edges (coil fins, etc.)
 - c) Hot refrigeration pipework
 - d) Possible live electrical components or terminals
- The refrigeration and compressed air circuits can operate at high pressures and unauthorised tampering may cause injury or damage.
- Discharge from the condensate drain will contain oil, and therefore should be disposed of safely.
- Do not place either temporary or permanent loads on or against the unit.

Mechanical

- The dryer shall be fully disconnected or isolated from the compressed air supply and any remaining pressure released safely.
- The refrigeration circuit shall be fully emptied of gas safely BEFORE work is attempted on any associated components. Refrigerant gas may be toxic and/or harmful (burns - both hot and cold), therefore use the necessary protective equipment (such as goggles and gloves) at all times when emptying the system,
- If any heat or flame is to be used on or near the unit care shall be taken to avoid contact with combustible surfaces. Furthermore, it should be noted that the insulation materials and refrigerant might give off toxic fumes when heated. Whenever heat or flame is used the working area shall be thoroughly ventilated BEFORE and DURING this operation. Proper fire precautions shall be observed and the necessary fire safety equipment on hand, typical for electrical, oil and foam fires,
- The refrigerant used is refrigerant R134a or R407C. No other type of refrigerant or mixture shall be used.
- If recharging or adding refrigerant to the unit ensure correct refrigerant and oil are used, check labels on compressor identifying refrigerant being used.
- Ester oils used in systems with R134a & R407C are very hygroscopic (adsorb moisture very quickly), therefore care should be taken to ensure that the systems and any ester oil containers are not left open to atmosphere for any length of time.
- If any oil is removed from the system it shall be disposed of safely. Do not re-use or use for any other purpose.
- When working on the dryers beware of any rotating components and any hot refrigerant pipework.
- Observe any safety labels fitted to various parts of the dryer.

Electrical

- The dryers are designed to operate only on a 220/240 volt, 1 phase, 50-60 Hz live neutral and earth supply. THE EARTH CONNECTION MUST NEVER BE OMITTED. The voltage tolerance for each model is shown on the respective wiring diagram in this Manual.
- The dryer must be fully isolated from the supply BEFORE maintenance work is started.
- The dryer MUST NOT be used on other supplies without prior approval from the manufacturer.
- The dryer should only be used in a SAFE (i.e. non- hazardous) area.
- Observe any electrical safety labels fitted to various parts of the dryer.
- Solenoid coils should not be removed from valve stem until they have been electrically disconnected.

Refrigerant Safety Data

Reactivity Data			
Stability	Unstable		Conditions to Avoid Use in presence of naked flames, red-hot surfaces. High moisture levels
	Stable	YES	
Incompatibility (Materials and Conditions to Avoid) May react violently with sodium, potassium, barium or other alkali or alkaline earth materials. Magnesium and alloys containing more than 2% magnesium. All finely divided metals.			
Hazardous Decomposition Products Halogen acids formed by thermal decomposition.			

Fire and Explosion Hazard Data			
Flash Point (°C)	Method	Auto-ignition Temperature (°C)	
---	---	---	
Flammable Limits (% by Vol. in Air)		Lower	Upper
Non Flammable		---	---
Would any material saturated with this product be subject to spontaneous combustion?	No	Materials:	
Fire Extinguishing Data Non flammable, not combustible.			
Special Fire Fighting Procedures Fire exposed containers should be kept cool with water sprays.			
Usual Fire and Explosion Hazards Will decompose in contact with high temperature sources, i.e. flames, electric arcs, etc. to produce irritating and highly toxic acidic products. Breathing apparatus should be worn if refrigerant is exposed to fire conditions. Containers may burst if overheated.			

Precautions in Handling and Use	
General Precautions Atmospheric levels should be minimised and kept as low as reasonably practicable below hygiene standard. Avoid inhalation of high concentrations of vapour. Heavy vapour collects at low levels. Ventilate by extraction at lowest level. Decomposes in flames, arcs and at red heat to toxic acid by-products. Avoid contact between liquid and skin or eyes.	
Ventilation Requirements Ventilation may be required to achieve a sufficiently low exposure level. Extract at lowest level. Vapour collects in pits, trenches, basements, sewers and in confined spaces and vessels.	Respiratory Protection Where doubt exists on atmospheric concentration and particularly in confined spaces, self-contained breathing apparatus should be considered. Breathing apparatus should always be worn in a fire situation.
Protective Clothes Where liquid splash is a possibility gloves suitable for use in low temperatures should be worn e.g. chlorobutyl rubber with cotton liners. Overalls.	Eye Protection Goggles.

Storage
Containers should be stored in a cool dry place away from fire risk and sources of heat. They should not be exposed to direct radiation from sources of heat such as steam or electric radiators. Do not heat containers beyond 45°C.

Health Hazard Data and First Aid

Short term effects of over exposure when:

In contact with skin: Liquid splashes may cause freeze burns. No information found on irritancy or sensitisation. There is no known hazard due to absorption through the skin.

In contact with eyes: Liquid splashes or vapour spray may result in freezing of tissue or eye fluids.

Inhaled: Very high concentrations may produce anaesthetic effects and can act as an asphyxiant by limiting available oxygen. They also may prove suddenly fatal (cardiac sensitisation).

10 min effective concentration 50	28%	(Rat)
15 min lethal concentration 50	> 80%	(Rat)
4 hr lethal concentration 50	> 50%	(Rat)
Threshold for cardiac sensitisation	7.5% 5 min	(Dog)

Ingested: Extremely unlikely to occur under normal industrial use. Should this occur freeze burns will result.

Long term effects of over exposure:

No effects have been seen in rats exposed to up to 50,000 ppm for 90 days. It is not teratogenic in rats or rabbits. Short-term screening tests for carcinogenicity have proved negative. No long-term effects were noted when administered by gavage to rats at a dose of 300 mg/kg/day for one year and the rats held for the remainder of their life span.

Occupational Exposure Limit (OEL):

1000 ppm v/v – 8 hr TWA value.

Emergency and First Aid Procedures:

Skin: Thaw affected areas with water, remove contaminated clothing carefully, wash affected areas of skin thoroughly with copious amounts of warm water. If symptoms occur, obtain medical attention.

Eyes: Irrigate with eyewash solution or clean water for at least 10 minutes. Obtain immediate medical attention.

Inhalation: Remove patient to fresh air, keep warm and at rest, administer oxygen if necessary. Apply artificial respiration if breathing has ceased. Apply external cardiac massage in the event of cardiac arrest. **The use of adrenaline or similar sympathomimetic drug should be avoided.** Obtain immediate medical attention.

Ingestion: Highly unlikely. Should this occur freeze burns will result.

Further Medical Advice

Symptomatic and supportive therapy as indicated. Cardiac sensitisation has been described which may, in the presence of circulating catecholamines such as adrenaline, give rise to cardiac arrhythmias and subsequent arrest following exposure to high concentrations of vapour. Therefore, adrenaline and similar sympathomimetic drugs should be avoided.

Spill or Leak Procedures

Steps to be taken in event of Spill or Release

Shut off leak if without risk. Allow spilled liquid to evaporate. Contain spillage with sand or earth, prevent liquid entering sewers, basements and pits since vapour may create suffocating atmosphere.

Neutralising Chemicals

None necessary.

Disposal Procedures

Best to recover and recycle. If this is not possible, destruction is to be in an approved facility, which is equipped to absorb and neutralise acids and other toxic processing products.

Installation - General

Storage

The equipment should be stored in a secure frost free area with a maximum ambient of 55°C and maximum humidity of 90% non-condensing.

Unpacking

Carefully remove the unit from its packing and examine it for obvious defects or damage including:

- Paint damage.
- Case deformation.
- Integrity of electrical cable.
- Breakage of gauge glass (where applicable).

If any of the above faults are noted, or any other defect or damage is observed and it becomes necessary to return the unit for rectification, this should be done in accordance with the procedure agreed with the supplier.

Moving

Due care shall be taken when moving the dryer not to cause injury to personnel through improper safety precautions.

NOTE: The dryer must be kept in the upright position at all times to avoid damaging the compressor.

Lifting

The units are designed for fork lifting from the base. The base is uneven – ensure that the forks are extended fully through.

Do NOT use convenient pipes, bolts or apertures in the dryer as lifting points.

Position of Unit

The dryer should be placed on a firm, level load bearing surface of adequate strength and a suitable area be left clear of obstruction at the inlet and outlet grilles and the access panels (see note reference ambient temperatures). To prevent air recirculation the condenser coil must be situated at least 500 mm from a wall, partition etc. Sufficient space must be left for service access around the unit.

The C series unit are NOT suitable for direct wall mounting.

Ambient Temperatures

Care should be taken to ensure that there is adequate air circulation and the Dryers should not be placed in areas where the ambient temperature is likely to exceed the recommended design maximum (refer to Technical Data tables).

Removal of Covers

General access for installation or maintenance is via the covers which are removable by removing the screws around the panels.

Corrosion

Air cooled units are designed for operation in normal ambient air. Any corrosive agent in the air such as ammonia, sea water spray etc. will cause corrosion and would require special protective measures. Corrosion can result in release of pressure and refrigerant.

Installation - Electrical

The C series Dryers require a 220/240 Volt 1 phase and neutral 50-60 Hz supply. A flying lead is installed on the dryer for convenience. The cable core colours are:

Brown	Live
Blue	Neutral
Green / Yellow	Earth

If the unit is connected to a junction box, receiving its supply from another source (e.g., auxiliary contacts of a main starter, or a relay), then it is important that electrical protection is provided by means of a suitably rated H.R.C. fuse located in the line. Installation must comply with the latest edition of IEE Wiring Regulations, Safety Standards and any Local Codes of Practice that apply.

Installation - Mechanical

Connect the compressed air pipework to the Dryer using approved pipe and fittings of the correct rating and type. To ensure damage does not occur to internal pipework and components during the connection process, remove access cover(s) and if necessary support the internal pipework / components. Please ensure that ALL shut off valves are fully open before starting unit.

The drain connection should be connected to a suitably sized drain line and piped to a suitable oil / water separator prior to drain.

Installation Recommendations

The compressed air pipework should incorporate sufficient shut-off valves to enable the dryer to be by-passed and/or disconnected in the event of repair or replacement.

A purge valve should also be fitted at a convenient point to enable the air pressure to be released safely and gradually before undoing any connections.

A suitably sized pressure safety device should be fitted to prevent over-pressurisation of the compressed air dryer.

If the compressor pumps intermittently, or the total air demand does not exceed the total flow rate of the compressor, the dryer **MUST** be installed downstream of the receiver.

If the receiver is sized to permit wide fluctuations on air demand or if peak demand exceed compressor maximum flow rate, the dryer **SHOULD** be installed upstream of the receiver.

A minimum of 5 micron (Denco recommend 1 micron) pre-filter must be fitted to remove impurities from the air prior to it entering the dryer. Additional filtration may be required downstream of the dryer subject to the site requirements.

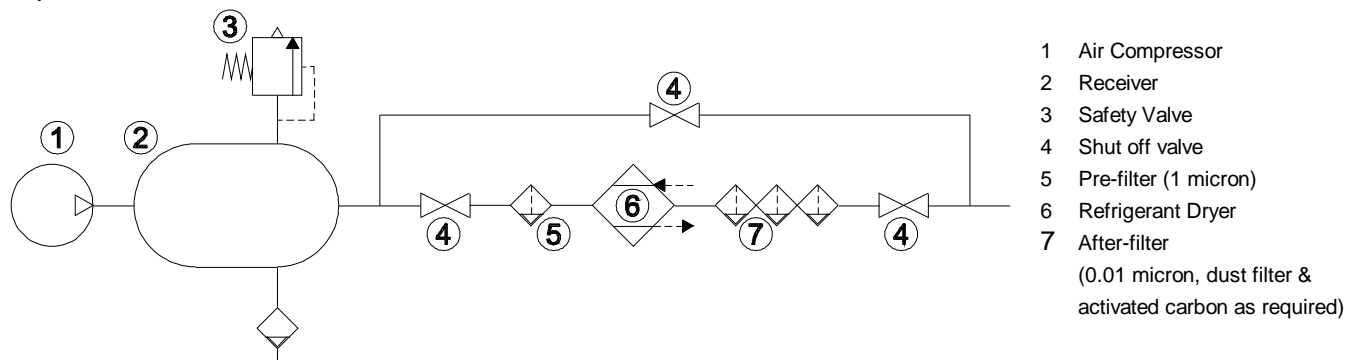

Commissioning

The units are factory pre-set and commissioned and should not need any field adjustment. However, if after a period of time the unit is found to be operating poorly or incorrectly, this may be due to a range of faults or problems which may be analysed by reference to the Fault Finding section of this manual.

Start-up Procedure

Important

Do not allow the compressed air to flow through the unit until the following checks have been made AND THE UNIT SWITCHED ON.

1. Switch the on-off switch / isolator to the "ON" (I) position. The following observations will indicate correct operation:
 - The fan will start
 - An airflow will be felt from the condenser discharge grille
 - After 2 minutes, the compressor will start and a low-level noise will be heard similar to that of a domestic refrigerator.
2. After a further 5 minutes, slowly allow the compressed air supply into the dryer.
3. Press the **VALVE** button to check the operation of the condensate discharge valve.

Note:

- Some safety cut outs are auto reset, and unless isolated from the mains the unit can be re-started without warning.
- Pressure switches should be adjusted with the power off.
- Any work done to the Compressed Air Dryer involving entry into the control panel, fitting gauges, adjusting controls, charging the system, evacuating the system or opening the system in any way, must be carried out by a FULLY QUALIFIED REFRIGERATION ENGINEER. A City and Guilds 2078 or equivalent certificate is strongly advised and will soon be mandatory.

Description of Operation

The saturated compressed air enters the evaporator and is pre-cooled by the outgoing cooler air. The internal refrigerant circuit is then used to further cool the air to its required dewpoint. Once dewpoint is achieved, the moisture condenses, and the water droplets are ejected via the condensate drain system. The cold, dry air is then warmed by the incoming warm air and discharged, dry, to the downstream pipework.

The refrigerant circuit is of conventional design operating on ozone benign Refrigerant R134a or R407c and incorporates an hermetic compressor, combined air/air and evaporator type heat exchanger, an air cooled condenser, an expansion device (capillary tube or thermostatic expansion valve), a filter/dryer, a hot gas by-pass valve. The refrigeration circuit is controlled by means of a simple but effective panel mounted controller

Schematic Flow and General Arrangement Drawings

Model Numbers	Schematic Flow Diagram Number	Outline Arrangement Drawing Number
C9-1, C14-1, C19-1	PS1061-C-021	PS1061-C-001
C31-2, C39-2, C58-2	PS1061-C-021	PS1061-C-002
C92-3, C120-3	PS1061-C-021	PS1061-C-003
C147-3	PS1061-C-021	PS1061-C-004
C175-4, C238-4	PS1061-C-021	PS1061-C-005

- VE CONDENSER FAN
- CD CONDENSER COIL
- FI FILTER DRYER
- IL SIGHT GLASS
- TM CAPILLARY TUBE
- EV EVAPORATOR & HEAT EXCHANGE
- DS DRAIN SYSTEM
- PB LOW PRESSUER CONTROL

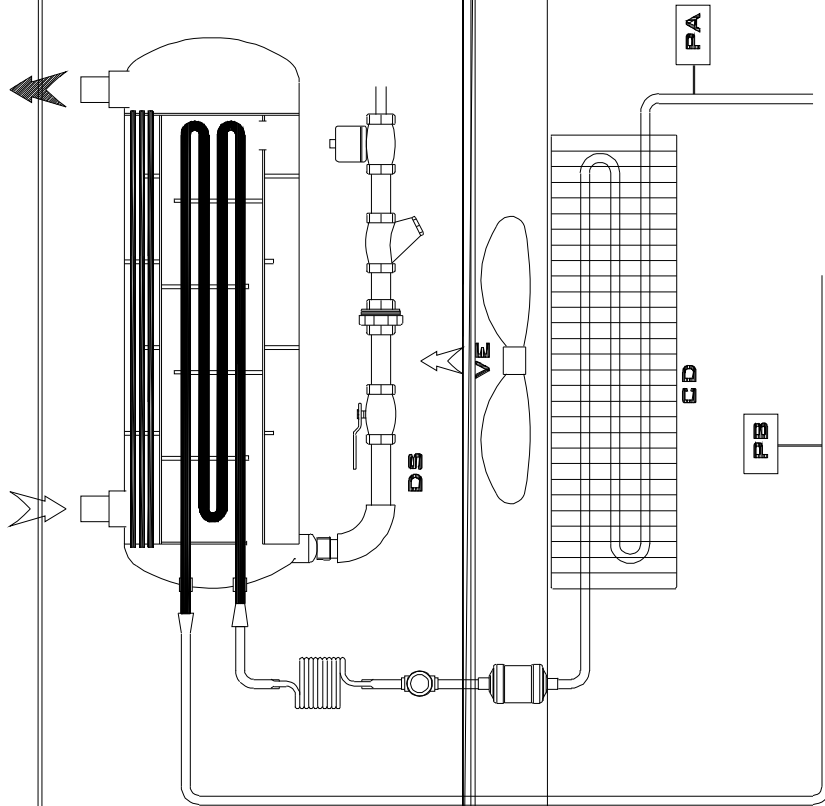

CP

PS1061-C-001

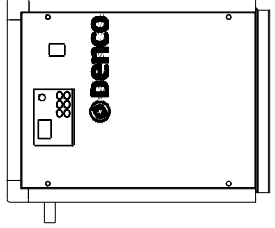
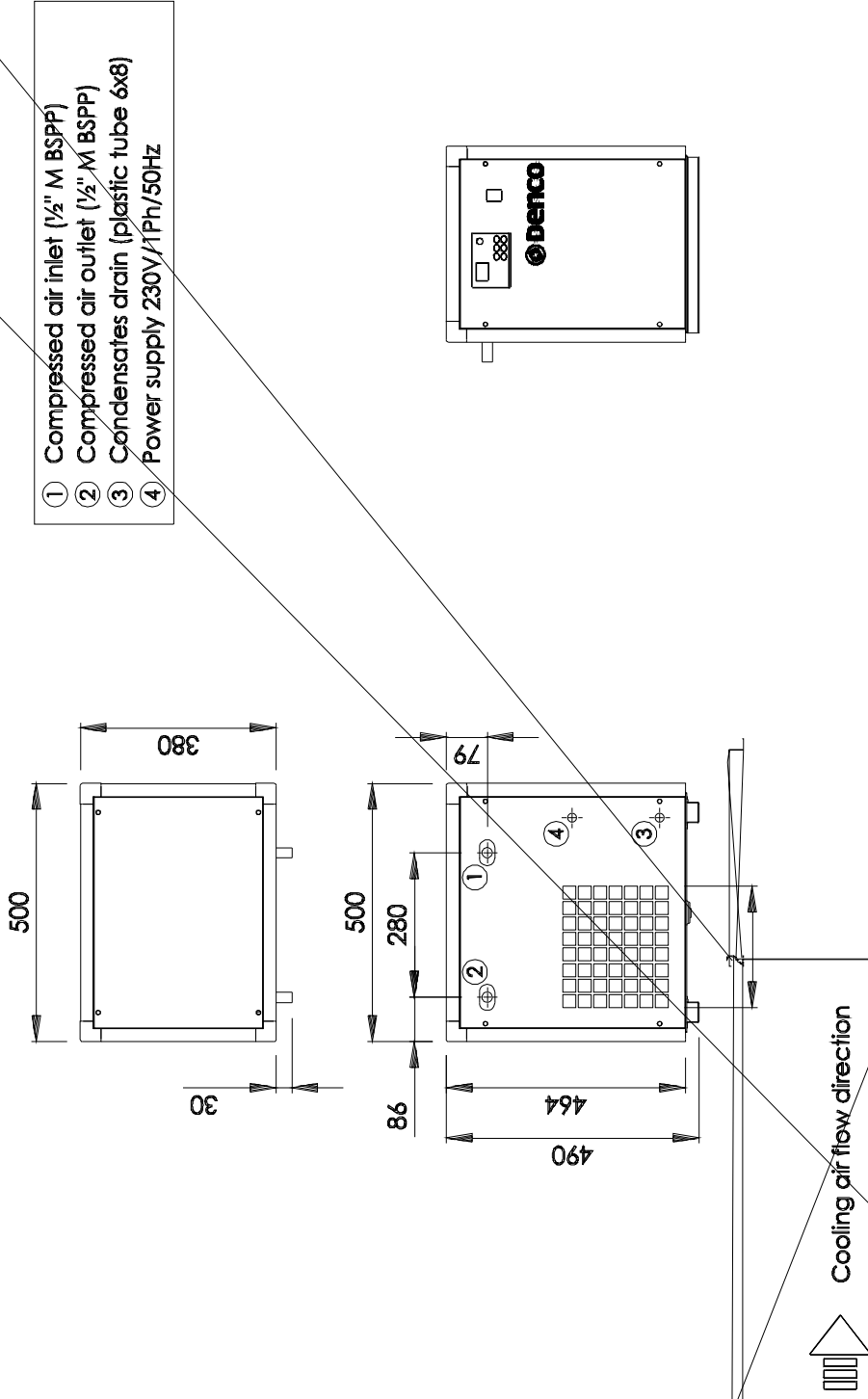

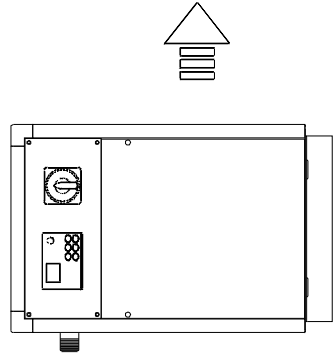
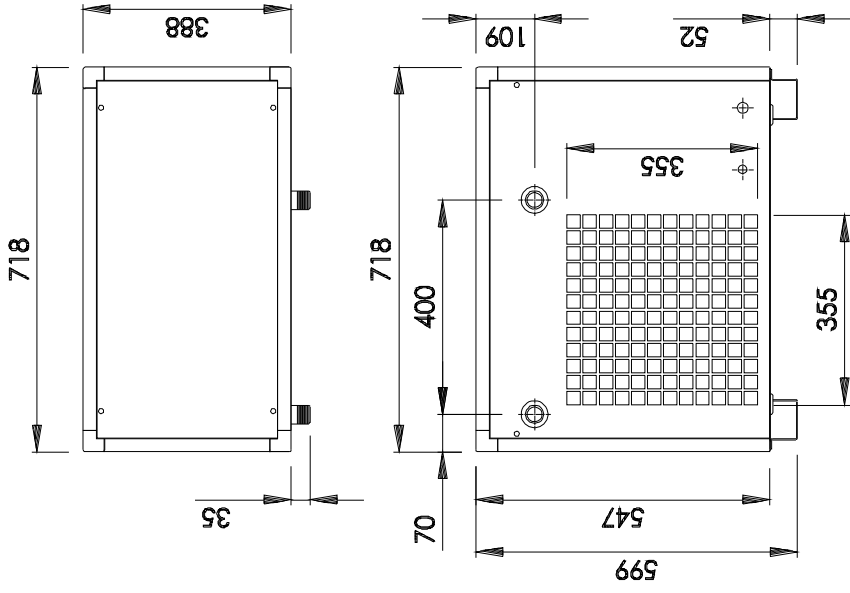

PLAN OF THE BUILDING

Hand-drawn wavy lines representing terrain or site boundaries.

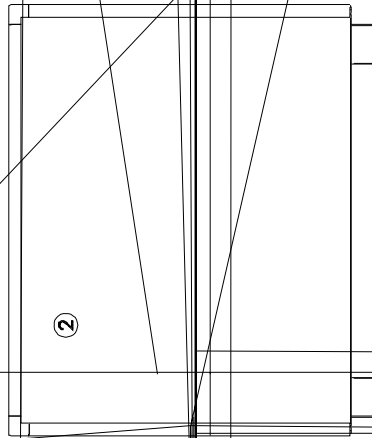
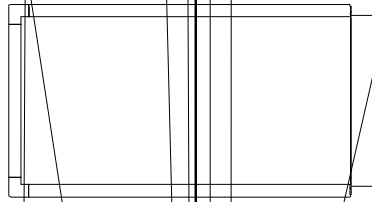

Handwritten notes and a table. The table has columns for 'Description', 'Date', and 'By'. The notes include 'H. D. ...' and 'S. ...'.

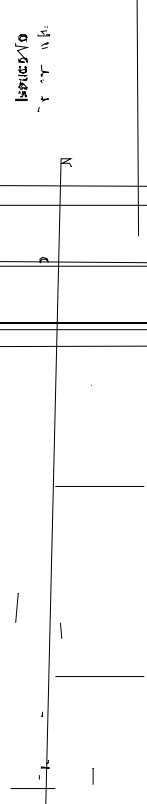

- ① Compressed air inlet (1 1/2" M BSPP)
- ② Compressed air outlet (1 1/2" M BSPP)
- ③ Condensate drain (plastic tube 6x8)
- ④ Power supply 230V/1Ph/50Hz

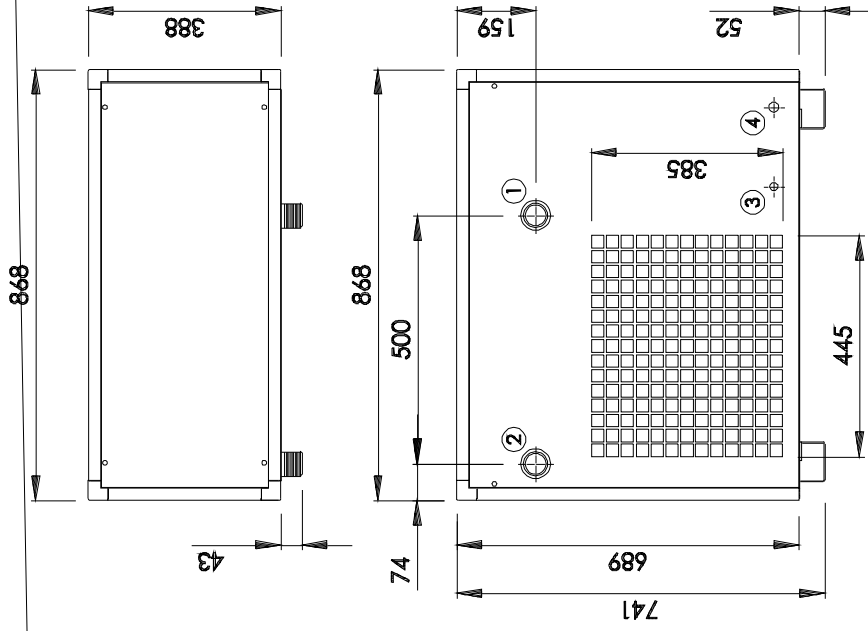

 Cooling air flow direction

For Sheet 1
 For Non-Sheetmetal Components, All Tolerances ± 1.0mm Unless Stated

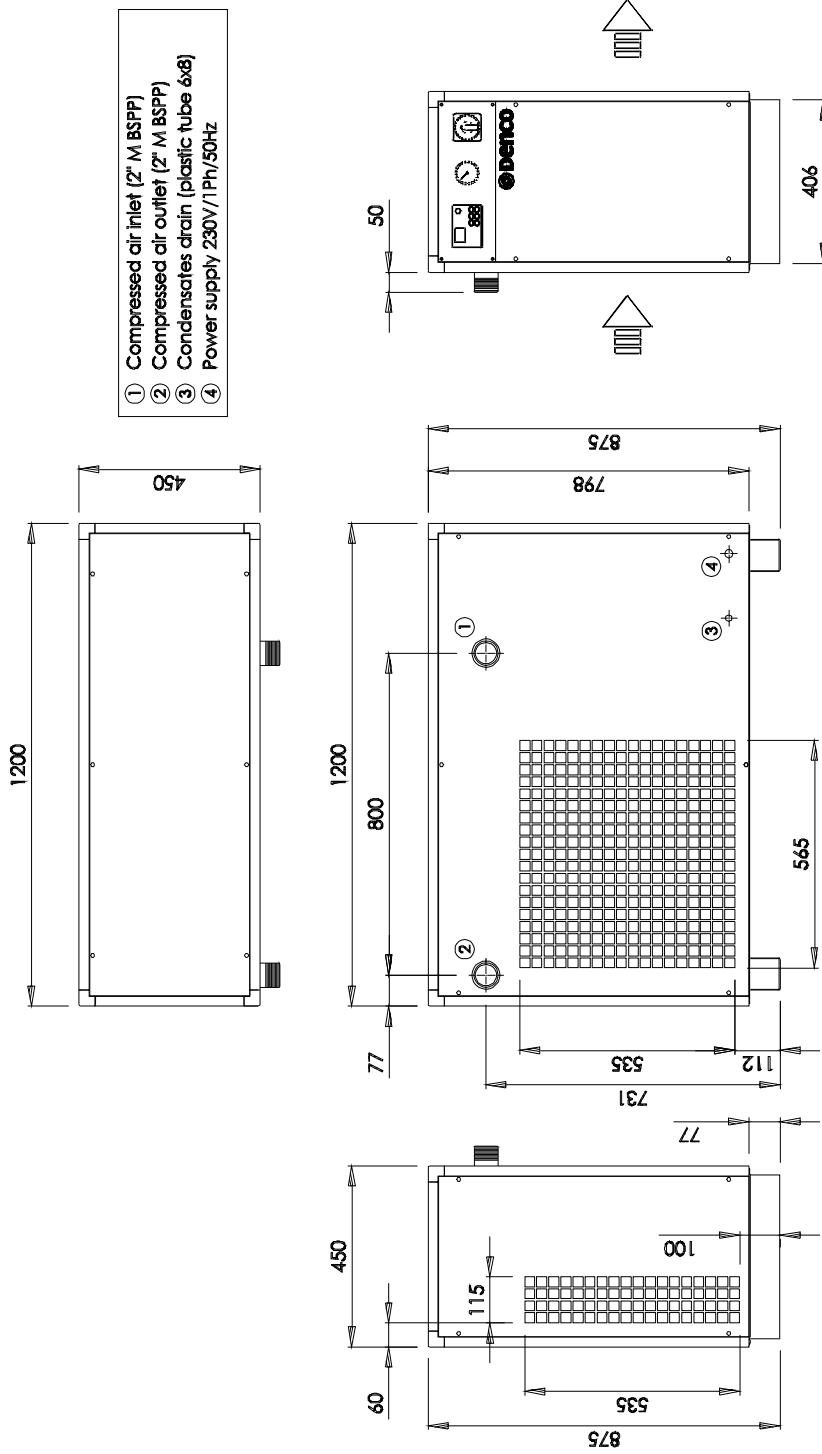

Rev	Description	Date	Init.
Contract	Preliminary	Pre-Production	Standard
Material		Dwg. Reference	
Quantity Required		Fold Reference	
Tool No.		File Location	

Technical Description of Components

1. Compressor

This is a fully hermetic, high back pressure single phase type; the internal components being mounted on springs to minimise vibration.

2. Heat Exchanger

The heat exchanger is coil / tube design and incorporates an air / air and refrigerant / air heat exchanger with an integral moisture separator

3. Air Cooled Condenser

A fan assisted air cooled condenser is used to remove the remaining heat from the refrigerant. Air movement is achieved by a multi-bladed propeller type fan directly driven by a single phase motor.

4. Hot Gas By-pass Valve

This valve is installed such that discharge gas may be diverted to the suction line when the suction temperature starts to fall below a preset level. This level is set such that the moisture removed from the system cannot freeze in the evaporator.

5. Controller

A digital readout temperature controller is fitted to allow the operating condition of the dryer to be monitored and drain valve settings to be adjusted.

6. Casing

The unit is housed in coated sheet steel casing. Removable covers are fitted where necessary to provide access for service or repair.

Technical Data Table

Model		C9-1	C14-1	C19-1	C31-2	C39-2	C58-2
Nominal Airflow [†]	m ³ /min	0.58	0.83	1.16	1.83	2.33	3.5
Nominal Pressure Drop	bar	0.3	0.3	0.3	0.3	0.3	0.3
Maximum Working Pressure	bar	13	13	13	13	13	13
Maximum Operating Ambient	°C	43	43	43	43	43	43
Maximum Standing Ambient	°C	53	53	53	53	53	53
Minimum Ambient	°C	5	5	5	5	5	5
Width	mm	380	380	380	388	388	388
Depth	mm	500	500	500	718	718	718
Height	mm	490	490	490	600	600	600
Air Connections	BSP	½	½	½	1	1	1
Drain Connections	mm od	8	8	8	8	8	8
Electrical Supply [§]	-	220-240 volt / 1 phase / 50-60 Hz					
Installed Power	kW	0.45	0.57	0.66	0.96	0.96	0.85
Full Load Current	Amps	2	2.6	3	4.35	4.35	3.9
Refrigerant	-	R134a			R407C		
Refrigerant Charge	kgs	0.35	0.35	0.55	0.8	0.8	1.3

Notes:

[†] Nominal airflow in m³/min FAD at 20°C, working pressure 7.0 bar gauge with an inlet temperature of 35°C in an ambient of 25°C. Please note: applying the Dryer for higher than standard ambient and / or air inlet temperature will derate the performance.

[‡] Pressure switches are factory set and must ON NO ACCOUNT be altered from the above settings.

[§] For voltage tolerance refer to respective schematic wiring diagram.

Technical Data Table

Model		C92-3	C120-3	C147-3	C175-4	C238-4
Nominal Airflow [†]	m ³ /min	5.5	7.16	8.83	10.5	14.33
Nominal Pressure Drop	bar	0.3	0.3	0.3	0.3	0.3
Maximum Working Pressure	bar	13	13	13	13	13
Maximum Operating Ambient	°C	43	43	43	43	43
Maximum Standing Ambient	°C	53	53	53	53	53
Minimum Ambient	°C	5	5	5	5	5
Width	mm	388	388	388	388	388
Depth	mm	868	868	868	1148	1148
Height	mm	740	740	740	875	875
Air Connections	BSP	1½	1½	1½	2	2
Drain Connections	mm od	8	8	8	8	8
Electrical Supply [§]	-	220-240 volt / 1 phase / 50-60 Hz				
Installed Power	kW	1.49	1.73	2.01	2.32	2.76
Full Load Current	Amps	6.76	7.86	9.16	10.56	12.56
Refrigerant	-	R407C				
Refrigerant Charge	kgs	1.8	1.8	2	2	2.5

Notes:

[†] Nominal airflow in m³/min FAD at 20°C, working pressure 7.0 bar gauge with an inlet temperature of 35°C in an ambient of 25°C. Please note: applying the Dryer for higher than standard ambient and / or air inlet temperature will derate the performance.

[‡] Pressure switches are factory set and must ON NO ACCOUNT be altered from the above settings.

[§] For voltage tolerance refer to respective schematic wiring diagram.

Electrical Description

Description of Components

1. "ON / OFF" Switch

This switches the live side of the power supply to the circuit. All models are fitted with a rotary type cam switch.

2. Compressor (complete with control box)

The compressor is a single phase type and incorporates a "start" circuit to avoid risk of a stalled motor on start-up.

3. General

The air cooled condenser fan will run under the control of the controller sensing the temperature in the compressor discharge line.

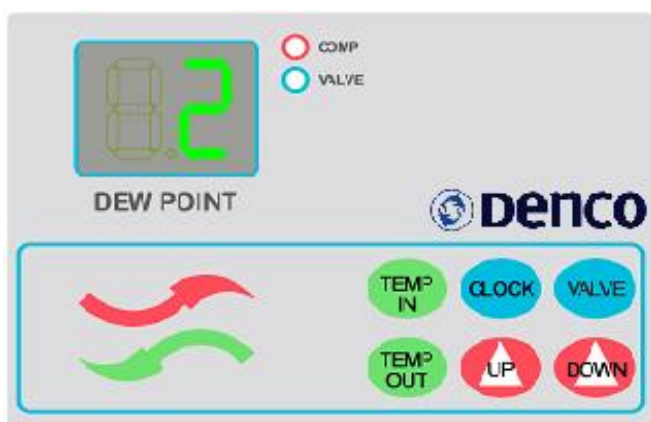

Controller

The above controller is fitted on the C series of compressed air dryers. It is used to control the fan and the hot gas valve (if fitted). It also displays the dewpoint temperature and controls the time settings for the drain valve. This time setting can be changed to suit the site requirements as follows.

Note: the "TEMP IN" and "TEMP OUT" buttons are not functional on the C series compressed air dryers

1. Valve Close Time (the time the valve is closed between discharges. Variable between 1 & 20 mins)

Hold the "UP" button for 15 seconds. The display will start blinking, displaying the valve close time. Press the "UP" or "DOWN" arrows while the display is blinking to change the setting. If any other button is pressed, the display will return to original display and ignore the new setting. After the new value has been set, leave the controller for 15 seconds. The display will return to the dewpoint value, and the new setting will be stored.

2. Valve Open Time (the time the valve is open to discharge. Variable between 4 & 20 secs)

Hold the "CLOCK" button for 15 seconds. The display will start blinking, displaying the valve open time. Press the "UP" or "DOWN" arrows while the display is blinking to change the setting. If any other button is pressed, the display will return to original display and ignore the new setting. After the new value has been set, leave the controller for 15 seconds. The display will return to the dewpoint value, and the new setting will be stored.

Wiring Diagrams

To assist understanding of the electrical circuitry the following wiring diagrams are included:

Model Numbers	Schematic Wiring Diagram Number
C9-1, C14-1, C19-1	PS1061-C-011
C31-2, C39-2, C58-2	PS1061-C-012
C92-3, C120-3, C147-3	PS1061-C-013
C175-4, C238-4	PS1061-C-014

PS1061-C-011

REV. 1
 DA 25-REV1
 10/1/01

For Shear
 For Non-Sheetmetal Components, All Tolerances ± 1.0mm Unless Stated

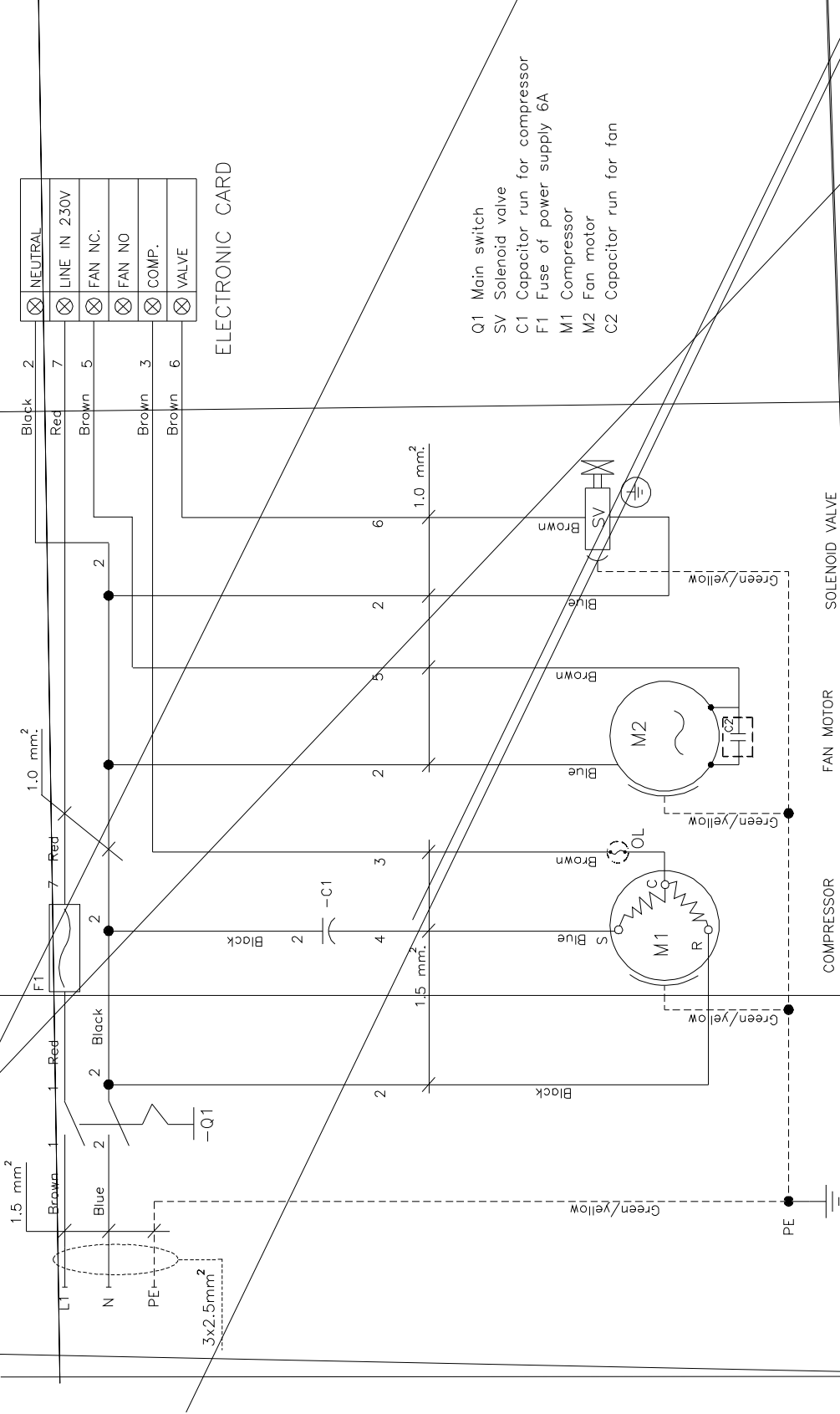

ELECTRONIC CARD

- Q1 Main switch
- SV Solenoid valve
- C1 Capacitor run for compressor
- F1 Fuse of power supply 6A
- M1 Compressor
- M2 Fan motor
- C2 Capacitor run for fan

Rev	Description	Date	Init	AW	Demo Works
A	First Issue	Sep 06	AW		
Contract	Preliminary			Standard	X
Material	N/A			N/A	
Quantity	N/A			N/A	
Required	N/A			N/A	
Tool No.	N/A			N/A	

Rev	Description	Date	Init	AW	Demo Works
A	First Issue	Sep 06	AW		
Contract	Preliminary			Standard	X
Material	N/A			N/A	
Quantity	N/A			N/A	
Required	N/A			N/A	
Tool No.	N/A			N/A	

Rev	Description	Date	Init	AW	Demo Works
A	First Issue	Sep 06	AW		
Contract	Preliminary			Standard	X
Material	N/A			N/A	
Quantity	N/A			N/A	
Required	N/A			N/A	
Tool No.	N/A			N/A	

SCHEMATIC WIR

REV. 1
 DA 25-REV1
 10/1/01

PS1061-C-011
 N/A

SEP 06
 N/A

PROCESS
 C9-1, C14-1, C19-1

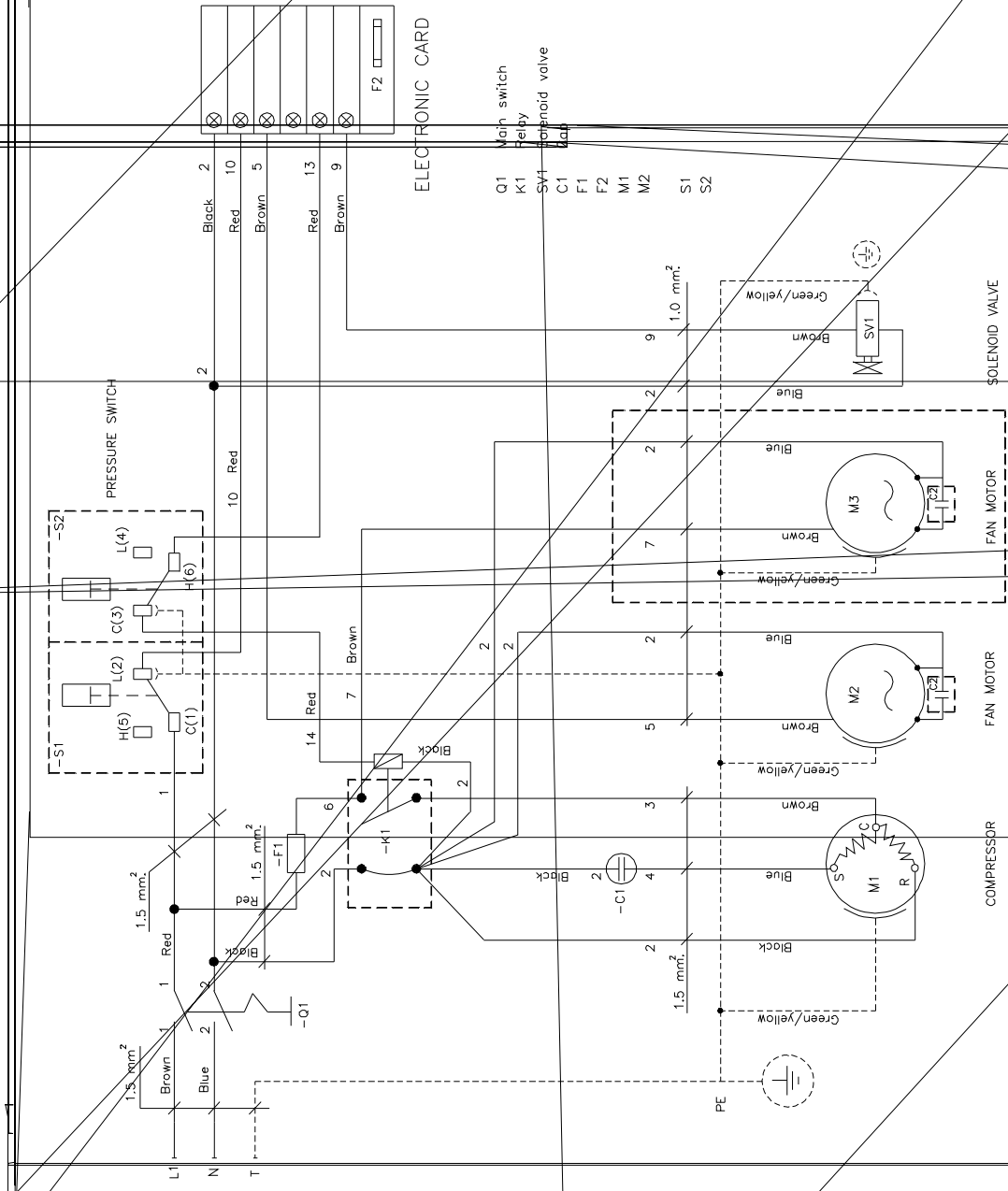

ELECTRONIC CARD

- Q1 Main switch
- K1 Relay
- SV1 Solenoid valve
- C1
- F1
- F2
- M1
- M2
- S1
- S2

SOLENOID VALVE

FAN MOTOR

FAN MOTOR

COMPRESSOR

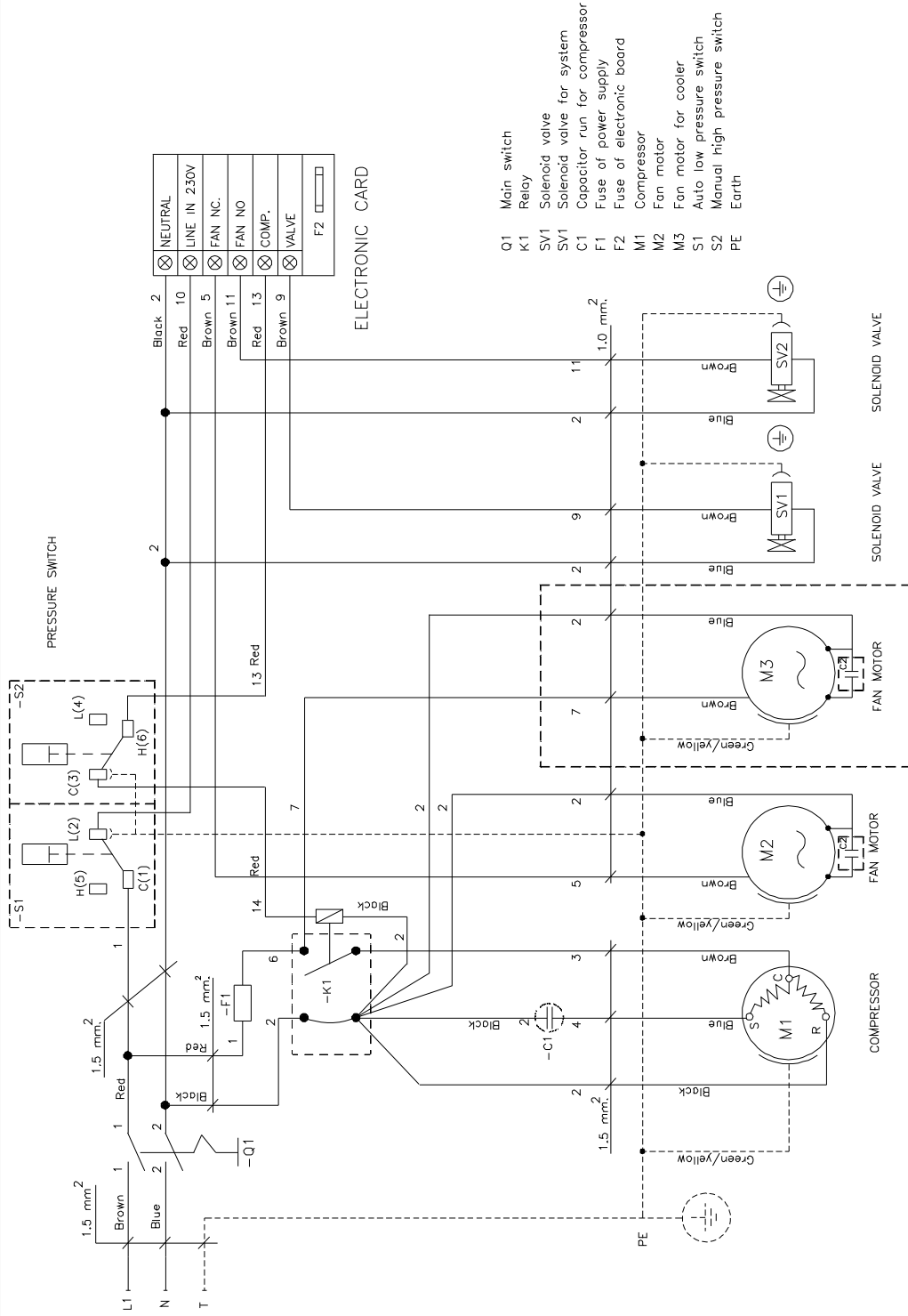

- Q1 Main switch
- K1 Relay
- SV1 Solenoid valve
- SV2 Solenoid valve for system
- C1 Capacitor run for compressor
- F1 Fuse of power supply
- F2 Fuse of electronic board
- M1 Compressor
- M2 Fan motor
- M3 Fan motor for cooler
- S1 Auto low pressure switch
- S2 Manual high pressure switch
- PE Earth

ELECTRONIC CARD

⊗	NEUTRAL
⊗	LINE IN 230V
⊗	FAN NC.
⊗	FAN NO.
⊗	COMP.
⊗	VALVE
□	F2

Rev	Contract Material	Preliminary	Pre-Production	Standard
			Dr	
	Quantity Required		Fold Reference	
	Tool No.		File Location	

11 | ANAD

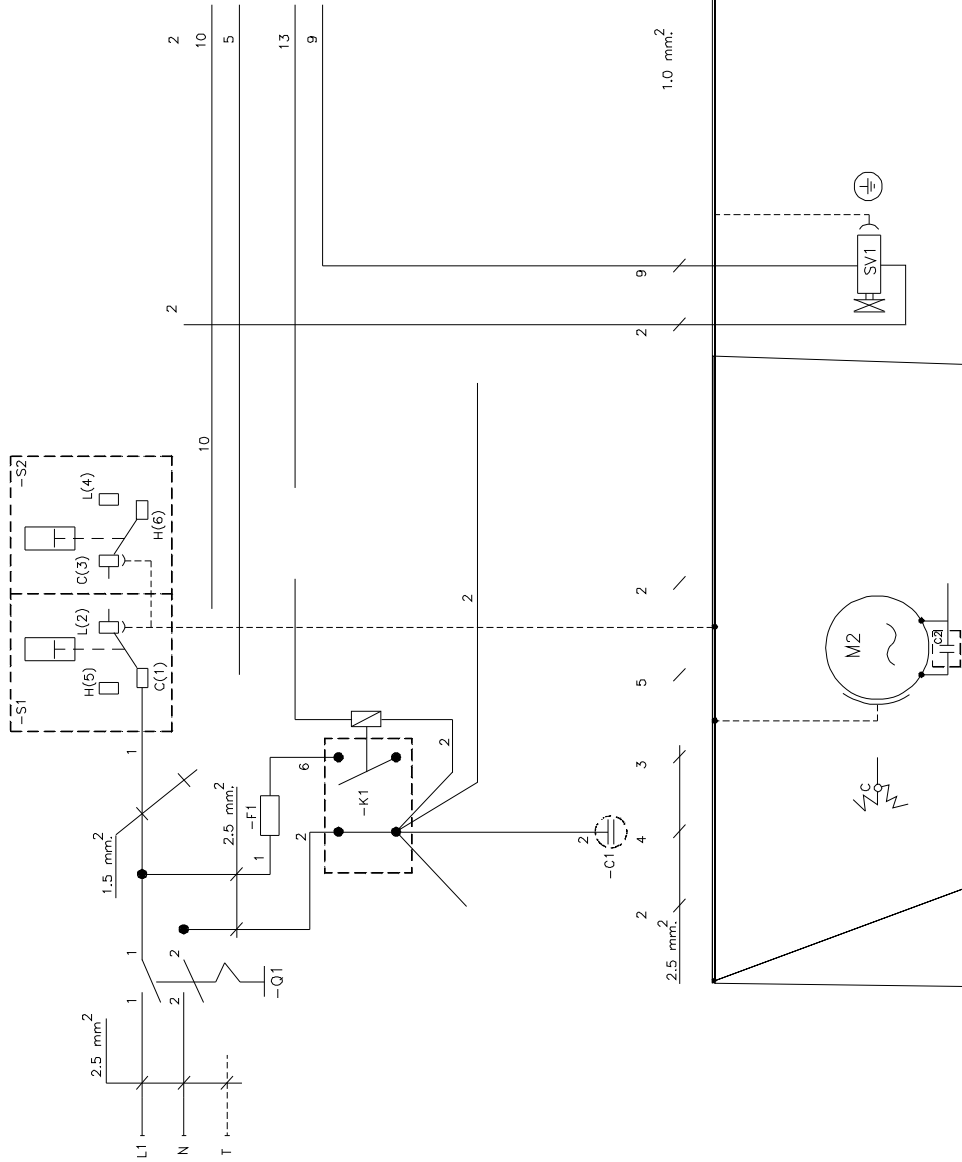

Control of Refrigerant Discharge

By international agreement, the worldwide use of certain refrigerants will be reduced in stages. To this end, listed below are suggestions on how refrigeration engineers can contribute by the discontinuing of releasing any refrigerant gas to the atmosphere. **Release of refrigerant to the atmosphere is an offence under Section 33 of the Environmental Protection Act 1990.**

DO NOT . . .

- (1) Blow off refrigerants to atmosphere.
- (2) Use refrigerants to clean coils etc.
- (3) Leak test using pure refrigerant.
- (4) Recharge before mending leaks.
- (5) Dispose refrigerant gas to waste.

DO . . .

- (1) Pump down into a receiver or empty cylinder using Reclaim Equipment.
- (2) Clean coils etc. using a hand brush, vacuum or compressed air.
- (3) Leak test using Nitrogen and just a trace of refrigerant gas.
- (4) Find and mend leaks before recharging system.
- (5) Send used refrigerant gas back for reprocessing.

Note: Disposal of refrigerants must be closely controlled. To dispose of refrigerant or a refrigerant system an approved agent must be used. If you have any doubt contact Denco Limited.

Log Book

In order to comply with BS EN 378, the user should keep an updated log book of the Compressed Air Dryer.

The log book should record:-

- (a) The details of all maintenance and repair work.
- (b) The quantities of new, re-used, or recycled refrigerant which have been charged on each occasion, and the quantities of refrigerant which have been transferred.
- (c) Any analysis of re-used refrigerant.
- (d) The source of re-used refrigerant.
- (e) Changes and replacements of components of the system.
- (f) The results of all periodic routine tests.
- (g) Significant periods of non-use.

The log book should be kept in the machinery room or stored in a computer system. It must be accessible to the competent person when servicing or testing.

Routine Maintenance

It is not normally necessary to open the refrigerant circuit. If a problem is suspected it is strongly recommended that unit maintenance or repair is undertaken by a CITY & GUILDS 2078 (or equivalent) COMPETENT REFRIGERATION ENGINEER. A City and Guilds 2078 (or equivalent) certificate will soon be mandatory.

Daily

- Check that the "ON / OFF" switch/isolator is in the "ON" or " I " position.
- Check condenser fan for airflow.

Weekly

- Check condensate drain operation.

Monthly

- Check condenser fins and grilles for cleanliness or damage. Repair as necessary.
- Check condenser fan blades for damage.

Quarterly

- Check tightness of electrical connections.
- Check all wiring for damage to insulation.
- Check running current.
- Clean condensate line strainer.

Bi-annually

- Check operation of refrigerant circuit (including temperatures and pressures)
- Check the pipework connections for

Annually

- Thoroughly clean unit including condenser fins.
- Check internal pipework and components for signs of wear or damage.

Note:

- Some safety cut outs are auto reset, and unless isolated from the mains the unit can be re-started without warning.
- Pressure switches should be adjusted with the power off.
- Any work done to the Compressed Air Dryer involving entry into the control panel, fitting gauges, adjusting controls, charging the system, evacuating the system or opening the system in any way, must be carried out by a FULLY QUALIFIED REFRIGERATION ENGINEER.

Fault Finding

The following fault finding chart relates various symptoms and faults of the refrigeration system.

Before attempting to identify a refrigeration system fault it must first be established that the DESIGN CONDITIONS to the compressed air system are being met i.e. flow, pressure and temperature.

Excessive overload will be caused by:

1. Excessive compressed air inlet temperature.
2. Compressed air pressure too low.
3. Compressed air flow in excess of design.
4. High ambient air temperature.

Dirt, scale and/or excessive oil in the compressed air may cause one or more of the following:

- Drain blockage leading to moisture being carried over into the compressed air system.
- Excessive pressure drop in compressed air circuit.
- Excessive fouling of the heat exchanger internal surfaces.

PROBLEM	CAUSE	SYMPTOM	REMEDY
A Dew point too high	Compressed air temperature too high.	The digital display panel indicates a value > 4C° permanently	Return the air inlet temperature to within the limits.
	Compressed air flow rate too high.	The digital display panel indicates a value > 4C° permanently	Correct the air flow rate to within the limits of the dryer.
	Compressed air pressure too low.	The digital display panel indicates a value > 4C° permanently	Correct the pressure to within the limits.
	Ambient temperature too high.	The digital display panel indicates a value > 4C° permanently	Correct the temperature to within the limits.
	Dirty fins of the condenser.	The digital display panel indicates a value > 4C° permanently	Clean the condensing unit fins.
	Condensing unit clogged.	The digital display panel indicates a value > 4C° permanently	Clean the condensing unit face.
	The fan runs backwards (three-phase)	The digital display panel indicates a value > 4C° permanently	Correct electrical connection (phase inversion)
	Refrigerant gas leak	The compressor top is very hot; Low pressure	Find the leak and repair it.
	The HP Pressure switch has tripped	The digital display panel is OFF	See note E.

Fault Finding continued

PROBLEM	CAUSE	SYMPTOM	REMEDY
B Excessive drop in compressed air pressure.	Compressed air flow rate too high.	Pressure downstream from the dryer lower than the expected value.	Reduce the compressed air flow rate.
	Condensate is Frozen.	Pressure downstream from the dryer lower than the expected value.	See note C.
	Exchanger Tubes soiled by impurities in the compressed air.	Pressure downstream from the dryer lower than the expected value...	Wash the heat exchanger tubes with a non-aggressive detergent solution. Check the filter upstream from the dryer.
C Compressed air does not flow through the dryer.	The condensate has frozen and blocked the passage as the probe is incorrectly positioned.	Compressed air does not flow through the dryer.	Position the probe in the centre of the CDT heat exchanger.
	The condensate has frozen and blocked the passage as the set point is programmed too low.	After starting the compressor, value 0 is reached in less than 2 minutes.	Increase the set point value.
	The condensate has frozen and blocked the passage as the electronic controller has failed.	The compressor stops. The compressor does not stop even if the digital display panel indicates 0 several minutes.	Change the electronic board
D There's liquid at air dryer outlet side	Solenoid valve doesn't work	There's no water or air to drain when VALVE button's pressed	Change the solenoid coil
	The draining system was clogged	T strainer was dirty	Clean the T strainer
	The working period of solenoid valve is not long enough	There's no water or air to drain when VALVE button's pressed	To make the period of solenoid valve working longer
	Solenoid valve was clogged	There's no water or air to drain when VALVE button's pressed	To clean solenoid valve
	Relay on electronics control board is not working.	To use volt metre to check that the relay surface will be closed to each other or not when VALVE button's pressed.	Change the electronics control board in case relay is not working.
	The tube system is in cold air which the temperature is lower than refined temperature of air under pressure and the tube is unprotected, in this case any liquid will be refined at outside of tube	No problem with the air dryer but with the outside environment	To protect the tube that is in low temperature area.

Fault Finding continued

PROBLEM	CAUSE	SYMPTOM	REMEDY
E High pressure switch stop working and have to control by manual	Fan motor stop working	Every LED at electronics control board doesn't light so its similar to no electric in circuit	Repair or change the fan
	The room temperature is too high	The room temperature is higher than appropriate temperature to work.	Adjust temperature in the room to the appropriate range or follow by the manual such as to increase flow rate air
	There's circulate hot air in the room causes from wrong installation	The room temperature is too high	To change the position of air dryer to rearrange the surroundings to limit circulate air
	The fins of refine unit were dirty.	At The display always show >4 °C.	Clean the refine unit fins
	Refine unit was clogged.	At The display always show >4 °C.	Clean the refine units
	Room has rather high temperature and fan has invert spin.(In case 3 phases used)	The cooling air had pass on fan and refine unit.	Invert the electric phase
	The refrigerant leaked.	Temperature of the dew point too high (Moisture might be observed near entrance).	Check for leaking marks
F Low pressure Switch stops working.	Air pressure too low, inlet temperature too high, ambient temperature too high.	The compressor stopped before reached the fixed balancing point value. Compressor restarts again after 2-3 minutes because the pressure is back to normal	Recommend to turn off the machine.
	Refrigerant pressure too low, refrigerant leak	-Top of the compressor is very hot Compressor stops then restarts after 2~3 seconds.	Check for leaking marks and refill the refrigerant
G Prevent compressor shut down	High pressure switch stopped working	-Top of the compressor is very hot -Compressor stopped working	Ensure the high temperature switch is in good condition; if not then change a new one.

Denco Limited - General Information

The safe choice for all your compressed air needs

With over 50 years experience in the design and manufacture of compressed air dryers and associated industrial plant, Denco has a wide portfolio of products offering all requisite features and benefits to meet the ever-increasing demands of international quality and environmental standards.

Whatever the application, products can be tailored to exact customer requirements. Consequently, Denco compressed air equipment can be found in all types and sizes of industry throughout the World, from small operator spray booths to major industrial installations.

With an open, flexible approach and a strong focus on Customer satisfaction, Denco has the skill and experience to provide the most suitable and cost effective solution to meet your needs.

The Quality

These units are designed and built using our unrivalled experience in compressed air drying, with extensive testing of components and complete systems. Every aspect is engineered to ensure maximum reliability, economy of operation and long working life, together with ease of installation and maintenance.

Denco Technical Support

Denco's Technical Support Department offers a nationwide service network for all users of Denco equipment.

Users with an existing maintenance contract on the mainland of Great Britain receive a target response time of 4 to 6 hours, 24 hours a day, 365 days per year.

Our Technical Support Engineers operate from strategically placed service depots supported by regional stores and a major central stores in Hereford.

To meet the complexity of equipment we train our engineers in both electrics and microprocessor controls.

Technical Support contracts are available offering scheduled preventative maintenance and emergency call-out nationwide. All schemes are tailored to suit the customer and site requirements.

Your Denco Distributor is:



Denco

compressed air systems

Denco Limited

Head Office

Dolphin House, Moreton Business Park,
Moreton-on-Lugg, Hereford, HR4 8DS, UK.

Telephone: +44 (0) 1432 277277

Fax: +44 (0) 1432 268005

Web: www.denco.co.uk



Due to our policy of continuous development and improvement, the specifications and data herein are subject to change without notice. We must therefore reserve the right to supply equipment that may differ from that described and illustrated herein. All information, including illustrations, contained in this manual, is believed to be accurate and reliable. Users, however, should independently evaluate the suitability of each product for their own application. Denco makes no warranties as to the accuracy or completeness of the information, and disclaims any liability regarding its use.
