

# ML-78III

(Gas/DSI/Phase 7 with F.S.S.)

## Installation Manual

**WARNING:** For your safety the information in this manual must be followed to minimize the risk of fire or explosion or to prevent property damage, personal injury or death.

— Do not store or use gasoline or other flammable vapors and liquids in the vicinity of this or any other appliance.

— **WHAT TO DO IF YOU SMELL GAS:**

- Do not try to light any appliance.
- Do not touch any electrical switch; do not use any phone in your building.
- Clear the room, building or area of all occupants.
- Immediately call your gas supplier from a neighbor's phone. Follow the gas supplier's instructions.
- If you cannot reach your gas supplier, call the fire department.

— Installation and service must be performed by a qualified installer, service agency or the gas supplier.

**AVERTISSEMENT:** Assurez-vous de bien suivre les instructions données dans cette notice pour réduire au minimum le risque d'incendie ou d'explosion ou pour éviter tout dommage matériel, toute blessure ou la mort.

— Ne pas entreposer ni utiliser d'essence ni d'autres vapeurs ou liquides inflammables à proximité de cet appareil ou de tout autre appareil.

— **QUE FAIRE SI VOUS SENTEZ UNE ODEUR DE GAZ:**

- Ne pas tenter d'allumer d'appareils.
- Ne touchez à aucun interrupteur. Ne pas vous servir des téléphones se trouvant dans le bâtiment.
- Évacuez la pièce, le bâtiment ou la zone.
- Appelez immédiatement votre fournisseur de gaz depuis un voisin. Suivez les instructions du fournisseur.
- Si vous ne pouvez rejoindre le fournisseur de gaz, appelez le service des incendies.

— L'installation et l'entretien doivent être assurés par un installateur ou un service d'entretien qualifié ou par le fournisseur de gaz.



For replacement parts, contact the reseller from which the dryer was purchased or

**American Dryer Corporation**

88 Currant Road

Fall River MA 02720-4781

Telephone: (508) 678-9000 / Fax: (508) 678-9447

e-mail: techsupport@amdry.com

www.amdry.com

## Retain This Manual In A Safe Place For Future Reference

**American Dryer Corporation** products embody advanced concepts in engineering, design, and safety. If this product is properly maintained, it will provide many years of safe, efficient, and trouble free operation.

*ONLY qualified technicians should service this equipment.*

**OBSERVE ALL SAFETY PRECAUTIONS** displayed on the equipment or specified in the installation manual included with the dryer.

The following “**FOR YOUR SAFETY**” caution **must be** posted near the dryer in a prominent location.

### FOR YOUR SAFETY

Do not store or use gasoline or other flammable vapors and liquids in the vicinity of this or any other appliance.

### POUR VOTRE SÉCURITÉ

Ne pas entreposer ni utiliser d'essence ni d'autres vapeurs ou liquides inflammables à proximité de cet appareil ou de tout autre appareil.

We have tried to make this manual as complete as possible and hope you will find it useful. **ADC** reserves the right to make changes from time to time, without notice or obligation, in prices, specifications, colors, and material, and to change or discontinue models. The illustrations included in this manual may not depict your particular dryer **exactly**.

## Important

For your convenience, log the following information:

DATE OF PURCHASE \_\_\_\_\_ MODEL NO. **ML-78 Phase 7 (DSI)**

RESELLER'S NAME \_\_\_\_\_

Serial Number(s) \_\_\_\_\_

\_\_\_\_\_

\_\_\_\_\_

Replacement parts can be obtained from your reseller or the **ADC** factory. When ordering replacement parts from the factory, you can FAX your order to **ADC** at (508) 678-9447 or telephone your order directly to the **ADC** Parts Department at (508) 678-9000. Please specify the dryer **model number** and **serial number** in addition to the **description** and **part number**, so that your order is processed accurately and promptly.

### “IMPORTANT NOTE TO PURCHASER”

Information **must be** obtained from your local gas supplier on the instructions to be followed if the user smells gas. These instructions **must be** posted in a prominent location near the dryer.

## **IMPORTANT**

**YOU MUST DISCONNECT AND LOCKOUT THE ELECTRIC SUPPLY AND THE GAS SUPPLY BEFORE ANY COVERS OR GUARDS ARE REMOVED FROM THE MACHINE TO ALLOW ACCESS FOR CLEANING, ADJUSTING, INSTALLATION, OR TESTING OF ANY EQUIPMENT PER OSHA (Occupational Safety and Health Administration) STANDARDS.**

“Caution: Label all wires prior to disconnection when servicing controls. Wiring errors can cause improper operation.”

«Attention: Au moment de l'entretien des commandes, étiquetez tous les fils avant de les débrancher. Des erreurs de câblage peuvent entraîner un fonctionnement inadéquat et dangereux.»

## **CAUTION**

**DRYERS SHOULD NEVER BE LEFT UNATTENDED WHILE IN OPERATION.**

## **WARNING**

**CHILDREN SHOULD NOT BE ALLOWED TO PLAY ON OR NEAR THE DRYER(S).  
CHILDREN SHOULD BE SUPERVISED IF NEAR DRYERS IN OPERATION.**

## **FOR YOUR SAFETY**

**DO NOT DRY MOP HEADS IN THE DRYER.  
DO NOT USE DRYER IN THE PRESENCE OF DRY CLEANING FUMES.**

## **WARNING**

**UNDER NO CIRCUMSTANCES should the dryer door switches, lint door switch, or heat safety circuit ever be disabled.**

### **WARNING**

The dryer *must never be* operated with any of the back guards, outer tops, or service panels removed. **PERSONAL INJURY OR FIRE COULD RESULT.**

### **WARNING**

**DRYER *MUST NEVER BE* OPERATED WITHOUT THE LINT FILTER/SCREEN IN PLACE, EVEN IF AN EXTERNAL LINT COLLECTION SYSTEM IS USED.**

### **IMPORTANT**

**PLEASE OBSERVE ALL SAFETY PRECAUTIONS displayed on the equipment and/or specified in the installation manual included with the dryer.**

Dryer *must not be* installed or stored in an area where it **will be** exposed to water or weather.

The wiring diagram for the dryer is located in the front electrical control box area.

### **IMPORTANT**

Dryer *must be* installed in a location/environment, which the ambient temperature remains between 40° F (4.44° C) and 130° F (54.44° C).

# *Table of Contents*

## **SECTION I**

<b>IMPORTANT INFORMATION .....</b>	<b>3</b>
A. Receiving and Handling .....	3
B. Safety Precautions .....	4

## **SECTION II**

<b>SPECIFICATIONS/COMPONENT IDENTIFICATION .....</b>	<b>6</b>
A. Specifications .....	6
B. Component Identification .....	8

## **SECTION III**

<b>INSTALLATION PROCEDURES .....</b>	<b>10</b>
A. Location Requirements .....	10
B. Unpacking/Setting Up .....	11
C. Dryer Enclosure Requirements .....	12
D. Fresh Air Supply Requirements .....	13
E. Exhaust Requirements .....	14
F. Electrical Information .....	18
G. Gas Information .....	22
H. Preparation for Operation/Start-Up .....	26
I. Preoperational Tests .....	27
J. Preoperational Instructions .....	29
K. Shutdown Instructions .....	29

## **SECTION IV**

<b>SERVICE/PARTS INFORMATION .....</b>	<b>30</b>
A. Service .....	30
B. Parts .....	30

## **SECTION V**

<b>WARRANTY INFORMATION.....</b>	<b>31</b>
A. Returning Warranty Cards .....	31
B. Warranty .....	31
C. Returning Warranty Parts .....	31

## **SECTION VI**

<b>ROUTINE MAINTENANCE .....</b>	<b>33</b>
A. Cleaning .....	33
B. Adjustments .....	34
C. Lubrication .....	34

<b>SECTION VII</b>	
<b>REVERSING TIMER SPIN/DWELL ADJUSTMENTS .....</b>	<b>35</b>
<b>SECTION VIII</b>	
<b>DATA LABEL INFORMATION .....</b>	<b>36</b>
<b>SECTION IX</b>	
<b>PROCEDURE FOR FUNCTIONAL CHECK OF REPLACEMENT</b>	
<b>COMPONENTS .....</b>	<b>38</b>
<b>SECTION X</b>	
<b>MANUAL RESET HI-LIMIT INSTRUCTIONS .....</b>	<b>40</b>
A. Phase 7 .....	40
B. Dual Timer .....	40
<b>SECTION XI</b>	
<b>FIRE SUPPRESSION SYSTEM (F.S.S.) .....</b>	<b>41</b>

# SECTION I

## IMPORTANT INFORMATION

### A. RECEIVING AND HANDLING

The dryer is shipped in a protective stretch wrap cover with protective cardboard corners and top cover (or optional box) as a means of preventing damage in transit. Upon delivery, the dryer and/or packaging, and wooden skid **should be** visually inspected for shipping damage. If any damage whatsoever is noticed, inspect further before delivering carrier leaves.

Dryers damaged in shipment:

1. **ALL** dryers **should be** inspected upon receipt and before they are signed for.
2. If there is suspected damage or actual damage, the trucker's receipt **should be** so noted.
3. If the dryer is damaged beyond repair, it **should be** refused. Those dryers, which were not damaged in a damaged shipment **should be** accepted, but the number received and the number refused **must be** noted on the receipt.
4. If you determine that the dryer was damaged after the trucker has left your location, you should call the delivering carrier's freight terminal immediately and file a claim. The freight company considers this concealed damage. This type of freight claim is very difficult to have reimbursed and becomes extremely difficult when more than a day or two passes after the freight was delivered. It is your responsibility to file freight claims. Dryer/parts damaged in transit **cannot** be claimed under warranty.
5. Freight claims are the responsibility of the consignee, and **ALL** claims **must be** filed at the receiving end. **ADC** assumes no responsibility for freight claims or damages.
6. If you need assistance in handling the situation, please contact the **ADC** Traffic Manager at (508) 678-9000.

**IMPORTANT:** The dryer *must be* transported and handled in an upright position at **ALL** times.

## B. SAFETY PRECAUTIONS

**WARNING:** For your safety, the information in this manual *must be* followed to minimize the risk of fire or explosion or to prevent property damage, personal injury, or loss of life.

**WARNING:** The dryer *must never be* operated with any of the back guards, outer tops, or service panels removed. **PERSONAL INJURY OR FIRE COULD RESULT.**

1. **DO NOT** store or use gasoline or other flammable vapors and liquids in the vicinity of this or any other appliance.
2. Purchaser/user should consult the local gas supplier for proper instructions to be followed in the event the user smells gas. The instructions **should be** posted in a prominent location.
3. WHAT TO DO IF YOU SMELL GAS...
  - a. **DO NOT** try to light any appliance.
  - b. **DO NOT** touch any electrical switch.
  - c. **DO NOT** use any phone in your building.
  - d. Clear the room, building, or area of **ALL** occupants.
  - e. Immediately call your gas supplier from a neighbor's phone. Follow the gas supplier's instructions.
  - f. If you **cannot** reach your gas supplier, call the fire department.
4. Installation and service **must be** performed by a qualified installer, service agency, or gas supplier.
5. Dryers **must be** exhausted to the outdoors.
6. Although **ADC** produces a very versatile dryer, there are some articles that, due to fabric composition or cleaning method, **should not be** dried in it.

**WARNING:** Dry only water washed fabrics. **DO NOT** dry articles spotted or washed in dry cleaning solvents, a combustible detergent, or "all purpose" cleaner.  
**EXPLOSION COULD RESULT.**

**WARNING:** **DO NOT** dry rags or articles coated or contaminated with gasoline, kerosene, oil, paint, or wax.  
**EXPLOSION COULD RESULT.**

**WARNING:** **DO NOT** dry mop heads. Contamination by wax or flammable solvents will create a fire hazard.

**WARNING:** **DO NOT** use heat for drying articles that contain plastic, foam, sponge rubber, or similarly textured rubber materials. Drying in a heated basket (tumbler) may damage plastics or rubber and may be a fire hazard.



7. A program **should be** established for the inspection and cleaning of lint in the burner area, exhaust ductwork, and area around the back of the dryer. The frequency of inspection and cleaning can best be determined from experience at each location.

**WARNING:** The collection of lint in the burner area and exhaust ductwork can create a potential fire hazard.

8. For personal safety, the dryer **must be** electrically grounded in accordance with local codes and/or the National Electrical Code ANSI/NFPA NO. 70-LATEST EDITION, or in Canada, the Canadian Electrical Codes Parts 1 & 2 CSA C22.1-1990 or LATEST EDITION.

**NOTE:** Failure to do so will VOID THE WARRANTY.

9. **UNDER NO CIRCUMSTANCES** should the dryer door switches, lint door switch, or heat safety circuit ever be disabled.

**WARNING: PERSONAL INJURY OR FIRE COULD RESULT.**

10. This dryer is not to be used in the presence of dry cleaning solvents or fumes.

11. Remove articles from the dryer as soon as the drying cycle has been completed.

**WARNING:** Articles left in the dryer after the drying and cooling cycles have been completed can create a fire hazard.

12. **READ AND FOLLOW ALL CAUTION AND DIRECTION LABELS ATTACHED TO THE DRYER.**

13. For safety, proper operation, and optimum performance, the dryer **must not be** operated with a load less than sixty-six percent (66%), 50 lbs (22.7 kg) of its rated capacity.

**WARNING: YOU MUST DISCONNECT AND LOCKOUT THE ELECTRIC SUPPLY AND THE GAS SUPPLY BEFORE ANY COVERS OR GUARDS ARE REMOVED FROM THE MACHINE TO ALLOW ACCESS FOR CLEANING, ADJUSTING, INSTALLATION, OR TESTING OF ANY EQUIPMENT PER OSHA (Occupational Safety and Health Administration) STANDARDS.**

**IMPORTANT: Dryer *must be* installed in a location/environment, which the ambient temperature remains between 40° F (4.44° C) and 130° F (54.44° C).**

# SECTION II

## SPECIFICATIONS/COMPONENT IDENTIFICATION

### A. SPECIFICATIONS

MAXIMUM CAPACITY (DRY WEIGHT)	75 lbs	<b>34 kg</b>	
BASKET (TUMBLER) DIAMETER	44-1/2"	<b>113.03 cm</b>	
BASKET (TUMBLER) DEPTH	24-7/8"	<b>63.18 cm</b>	
BASKET (TUMBLER) VOLUME	22.4 cu ft	<b>0.634 cu m</b>	
BASKET (TUMBLER) MOTOR	1 hp*	<b>0.746 kW</b>	
DOOR OPENING (DIAMETER)	31-3/8"	<b>79.7 cm</b>	
F.S.S. WATER CONNECTION	3/4-11.5 NH		
DRYERS PER 20'/40' CONTAINER	8/18		
DRYERS PER 48'/53' TRUCK	24/26		
<b>Gas</b>	VOLTAGE AVAILABLE	120-480v 1, 3Ø 50/60 Hz	
	APPROX. NET WEIGHT	888 lbs	<b>402.8 kg</b>
	APPROX. SHIPPING WEIGHT	938 lbs	<b>425.5 kg</b>
	HEAT INPUT	204,000 Btu/hr	<b>51,408 kcal/hr</b>
	AIRFLOW	1,200 cfm	<b>33.98 cmm</b>
	INLET PIPE CONNECTION	3/4" F.N.P.T.**	

*Shaded areas are stated in metric equivalents*

9/23/03

\* For non-reversing models only.

\*\* A minimum of 3/4" pipe **must be** supplied to the gas inlet for each dryer.

**NOTE:** ADC reserves the right to make changes in specifications at any time without notice or obligation.

# Specifications

**DRYER NOTES:**

- A MINIMUM OF 3/4 in PIPE MUST BE SUPPLIED TO THE GAS INLET FOR EACH DRYER. SIZE OF PIPING TO DRYER VARIES WITH INSTALLATION CONDITIONS.
- TOP SECTION CAN BE REMOVED FOR EASY INSTALLATION. WITH TOP MODULE REMOVED THE HEIGHT OF THE CABINET IS REDUCED TO 70 3/8 in. (178.75 cm).
- 3 in (7.62 cm) HIGH COVER PANEL IS REMOVABLE FOR EASE OF INSTALLATION, REDUCING THE CABINET HEIGHT TO 81 1/2 in (207 cm).
- DUCTWORK SIZE VARIES WITH INSTALLATION CONDITIONS.
- EXHAUST STATIC PRESSURE MUST BE NO LESS THAN 0 AND MUST NOT EXCEED 0.3" (0.74 MB) WATER COLUMN.

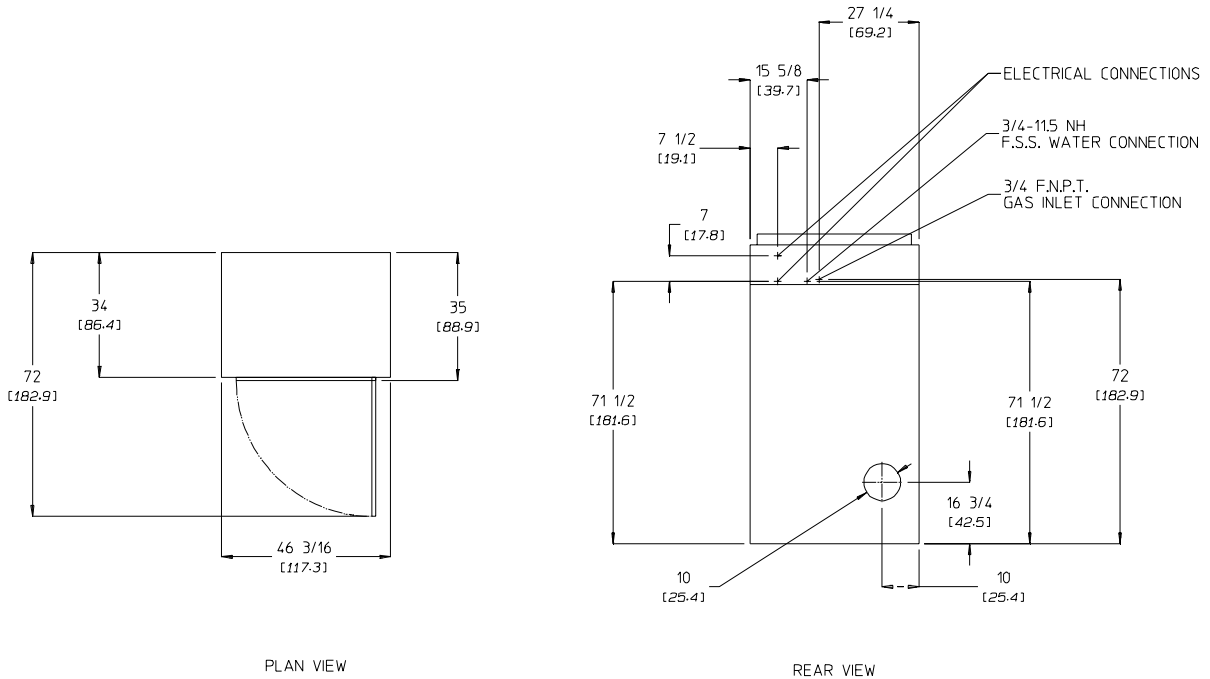

KLAMBERT 9/22/03

**NOTE:** ADC reserves the right to make changes in specifications at any time without notice or obligation.

## B. COMPONENT IDENTIFICATION

### 1. Dryer Front View

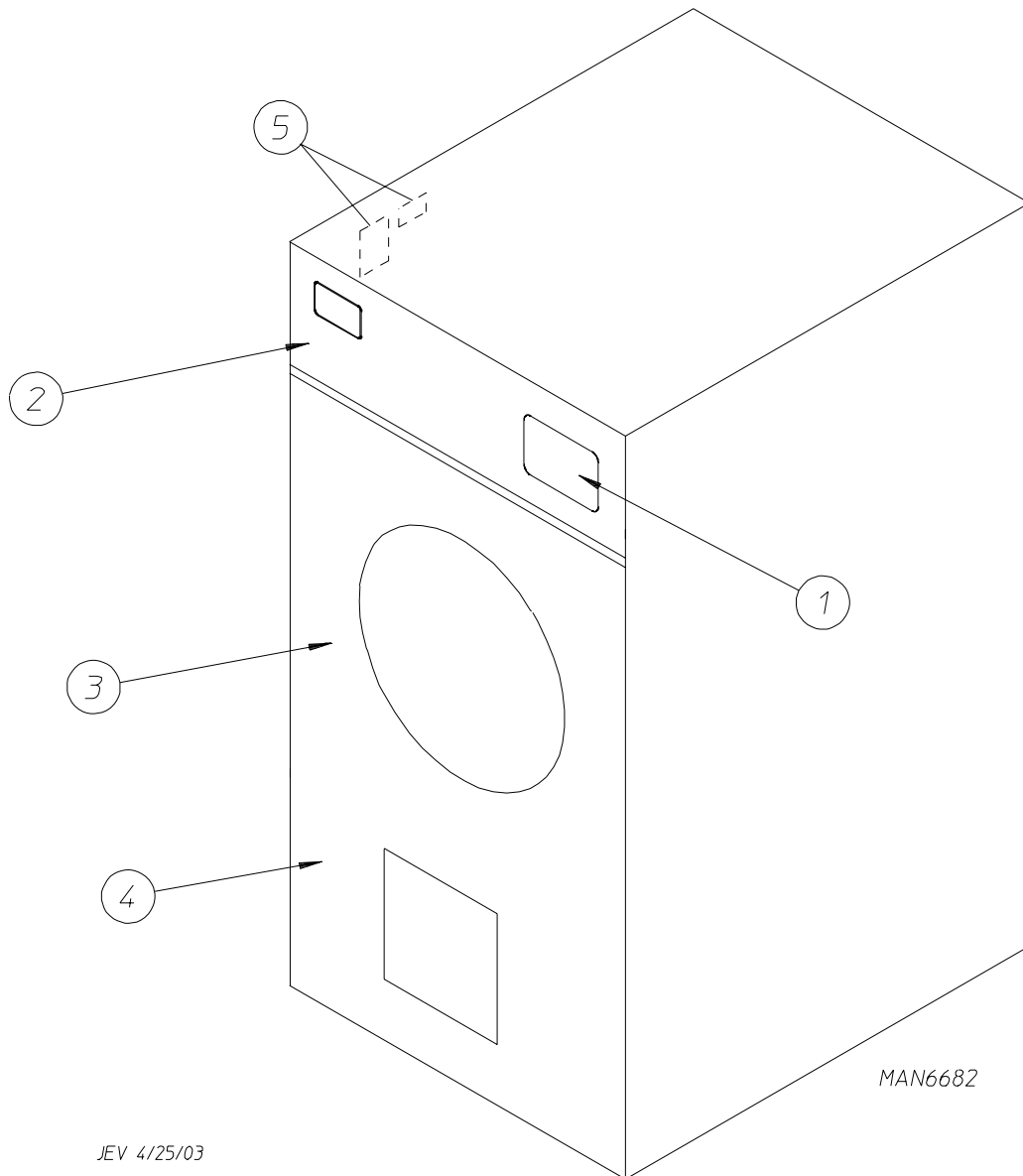

<u>Illus. No.</u>	<u>Description</u>
-------------------	--------------------

- |   |   |
|---|---|
| 1 | Controls  |
| 2 | Control (top access) Door Assembly                      |
| 3 | Main Door Assembly                                      |
| 4 | Lint Compartment Area (lint screen located behind door) |
| 5 | Data Label and Installation Label                       |

## 2. Dryer Rear View

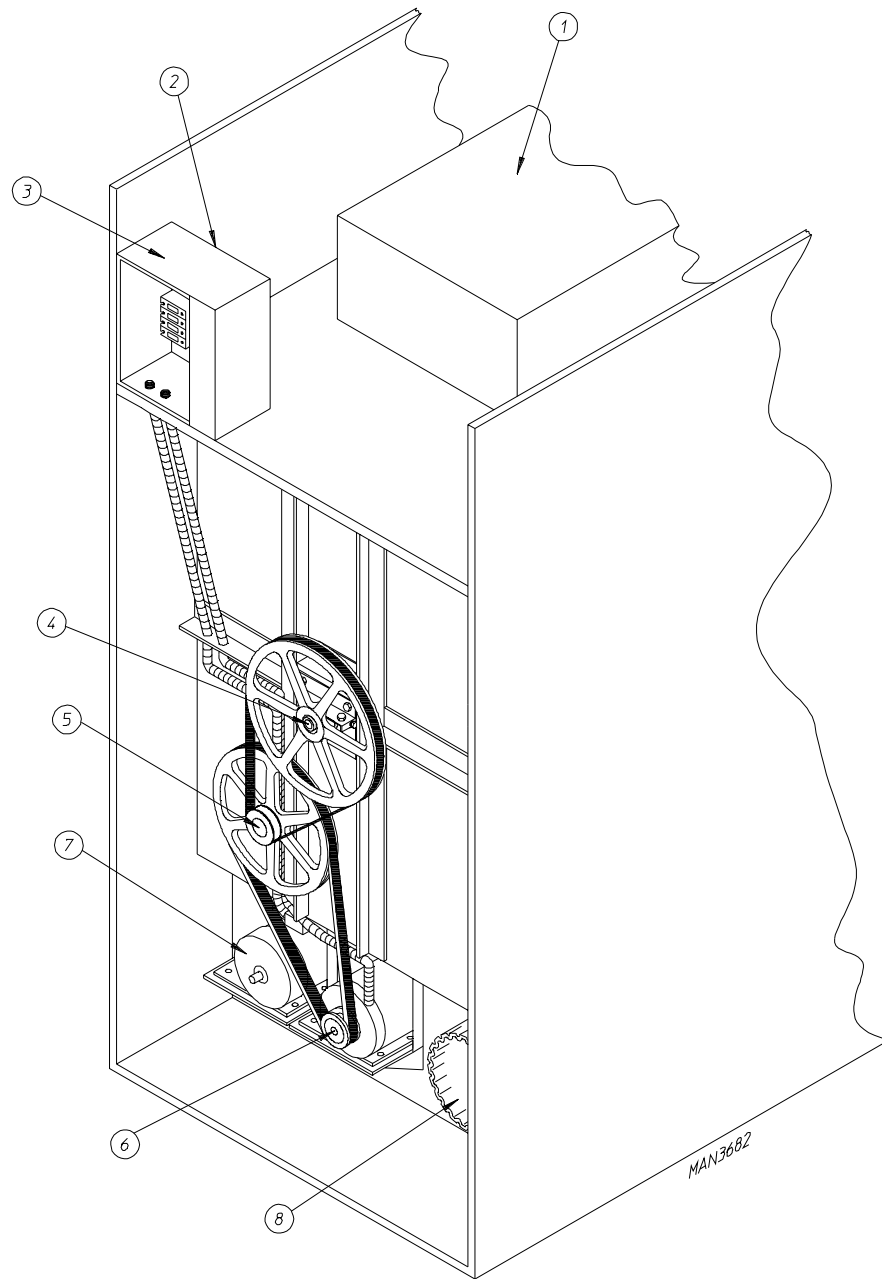

<u>Illus. No.</u>	<u>Description</u>
1	Heating Unit
2	Outer Top Area
3*	Electric Service Relay Box
4	Basket (tumbler) Bearing Mount Assembly
5	Idler Bearing Mount Assembly
6	Basket (tumbler) (drive) Motor Assembly (for reversing models only)
7	Blower Motor Assembly
8	Dryer Exhaust

\* Electrical service connections are made in this box.

# SECTION III

## INSTALLATION PROCEDURES

Installation **should be** performed by competent technicians in accordance with local and state codes. In the absence of these codes, the installation **must conform** to applicable American National Standards: ANSI Z223.1-LATEST EDITION (National Fuel Gas Code) or ANSI/NFPA NO. 70-LATEST EDITION (National Electrical Code) or in Canada, the installation **must conform** to applicable Canadian Standards: CAN/CGA-B149.1-M91 (Natural Gas) or CAN/CGA-B149.2-M91 (Liquid Propane [L.P.] Gas) or LATEST EDITION (for General Installation and Gas Plumbing) or Canadian Electrical Codes Parts 1 & 2 CSA C22.1-1990 or LATEST EDITION (for Electrical Connections).

### A. LOCATION REQUIREMENTS

Before installing the dryer, be sure the location conforms to local codes and ordinances. In the absence of such codes or ordinances the location **must conform** with the National Fuel Gas Code ANSI.Z223.1 LATEST EDITION, or in Canada, the installation **must conform** to applicable Canadian Standards: CAN/CGA-B149.1-M91 (Natural Gas) or CAN/CGA-B149.2-M91 (L.P. Gas) or LATEST EDITION (for General Installation and Gas Plumbing).

1. The dryer **must be** installed on a sound level floor capable of supporting its weight. Carpeting **must be** removed from the floor area that the dryer is to rest on.

**IMPORTANT:** “The dryer *must be* installed on noncombustible floors only.”

2. The dryer **must not be** installed or stored in an area where it will be exposed to water and/or weather.
3. Provisions for adequate air supply **must be** provided as noted in this manual (refer to **Fresh Air Supply Requirements** in Section D).
4. Clearance provisions **must be** made from combustible construction as noted in this manual (refer to **Dryer Enclosure Requirements** in Section C).
5. Provisions **must be** made for adequate clearances for servicing and for operation as noted in this manual (refer to **Dryer Enclosure Requirements** in Section C).
6. Dryer **must be** exhausted to the outdoors as noted in this manual (refer to **Exhaust Requirements** in Section E).
7. Dryer **must be** located in an area where correct exhaust venting can be achieved as noted in this manual (refer to **Exhaust Requirements** in Section E).

**IMPORTANT:** Dryer *should be* located where a minimum amount of exhaust duct will be necessary.

8. The dryer **must be** installed with a proper exhaust duct connection to the outside.
9. The dryer **must be** installed with provisions for adequate combustion and make-up air supply.

**CAUTION:** This dryer produces combustible lint and *must be* exhausted to the outdoors. Every 6 months, inspect the exhaust ducting and remove any lint buildup.

**IMPORTANT:** Dryer *must be* installed in a location/environment, which the ambient temperature remains between 40° F (4.44° C) and 130° F (54.44° C).

## B. UNPACKING/SETTING UP

Remove protective shipping material (i.e., plastic wrap, and/or optional shipping box) from dryer.

**IMPORTANT:** Dryer *must be* transported and handled in an upright position at **ALL** times.

The dryer can be moved to its final location while still attached to the skid or with the skid removed. To unskid the dryer, locate and remove the four (4) bolts securing the base of the dryer to the wooden skid. Two (2) are at the rear base (remove the back panel for access) and two (2) are located in the bottom of the lint chamber. To remove the two (2) bolts located in the lint chamber area, remove the lint door.

To increase bearing life and improve efficiency, the dryer **should be** tilted slightly to the rear.

The lint coop is supported during shipping by a bracket. **REMOVE THIS BRACKET BEFORE STARTING THE DRYER.**

If more headroom is needed when moving dryer into position, the top console (module) may be removed.

### 1. To Remove Top Console (Module)

- a. Disconnect the ground wire (A) at the rear upper left hand corner of dryer.
- b. Remove the four (4) sets of nuts and washers (B) holding the console (module) to base.
- c. Open the control door/control panel and disconnect the white 9-pin plug connector (C) located in the base of the control box.
- d. Disconnect motor harness(es) (D) located in rear electrical box.
- e. Disconnect 2-pin connector (E) located in rear electrical box. (On some dryers, this is optional.)
- f. Lift the console (module) off the dryer base.

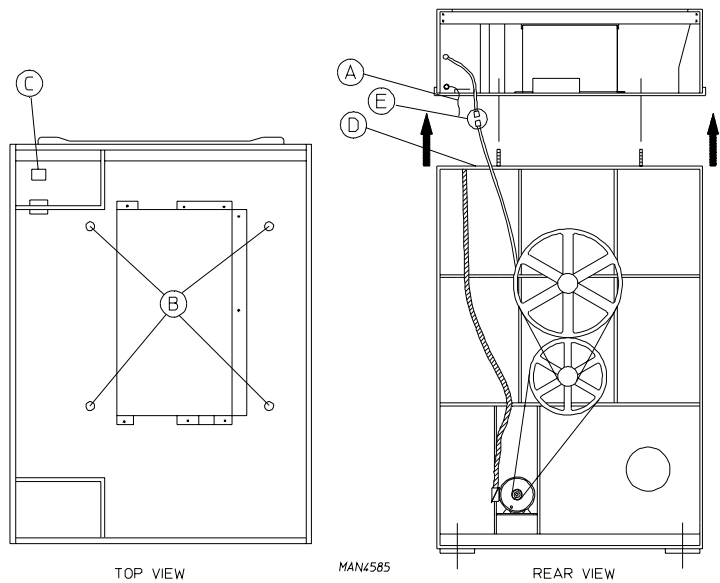

## C. DRYER ENCLOSURE REQUIREMENTS

Bulkheads and partitions **must be** made of noncombustible materials and **must be** located a minimum of 12-inches (30.48 cm), 18-inches (45.72 cm) or more is recommended for ease of installation, maintenance, and service above the dryer outer top, except along the front of the dryer which may be partially closed in if desired. The clearance between the bulkhead header and the dryer **must be** a minimum of 4-inches (10.16 cm) and must not extend more than 4-inches (10.16 cm) to the rear of the front. The bulkhead facing **must not be** closed in **ALL** the way to the top of the dryer. A 1-inch (2.54 cm) clearance is required.

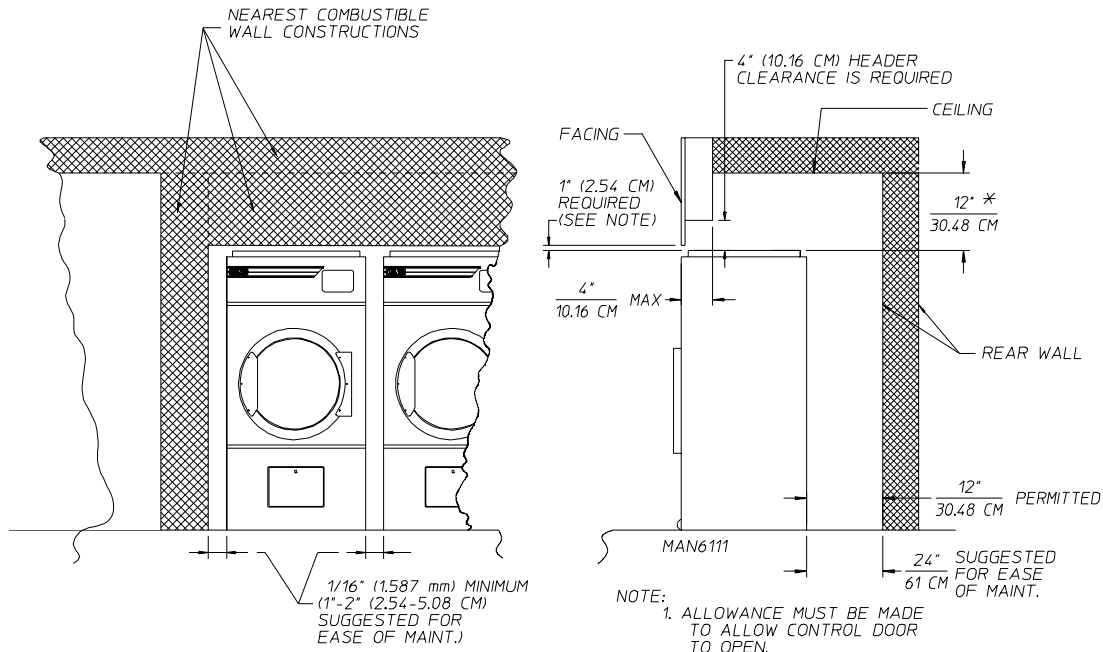

\*IN CASES WHERE SPRINKLER HEADS ARE OVER THE DRYERS 18" (45.72 CM) IS SUGGESTED.

INSTALLATION: DRYER CLEARANCE TO ADJACENT WALL STRUCTURES.

TCOSTA 03/15/02

**NOTE:** Allowances **must be** made for opening the control door.

Dryers may be positioned sidewall to sidewall. However, a 1/16" (1.587 mm) minimum allowance **must be** made for the opening and closing of the control door and the lint door. It is suggested that the dryer be positioned about 2 feet (0.61 meters) away from the nearest obstruction for ease of installation, maintenance, and service (to be measured from the back guard). Refer to the **illustration above** for details.

**NOTE:** Air considerations are important for proper and efficient operation.

**IMPORTANT:** Even though a minimum of only 12-inches (30.48 cm) is required behind the dryer, 18-inches (45.72 cm) or more is suggested (especially when vertical venting is used). The additional clearance is advantageous for ease of installation and service.

**IMPORTANT:** When fire sprinkler systems are located above the dryers, a minimum of 18-inches (45.72 cm) above the dryer console (module) is required. Dryers may be positioned sidewall to sidewall, however, a 1/16" (1.587 mm) minimum allowance is required between dryers (or wall) for ease of installation and maintenance. Allowances **must be** made for the opening and closing of the control door and the lint door.



## D. FRESH AIR SUPPLY REQUIREMENTS

When the dryer is operating, it draws in room air, heats it, passes this air through the basket (tumbler), and exhausts it out of the building. Therefore, the room air **must be** continually replenished from the outdoors. If the make-up air is inadequate, drying time and drying efficiency will be adversely affected. Ignition problems and sail switch “fluttering” problems may result, as well as premature motor failure from overheating.

Air supply (make-up air) **must be** given careful consideration to ensure proper performance of each dryer. An unrestricted source of air is necessary for each dryer. An airflow of 1,200 cfm (cubic feet per minute) (33.98 cmm [cubic meters per minute]) **must be** supplied to each gas dryer. As a general rule, an unrestricted air entrance from the outdoors (atmosphere) of a minimum of 1-1/2 square feet (0.41 square meters) is required for each dryer. The dryer **must be** installed with provisions for adequate combustion and make-up air supply.

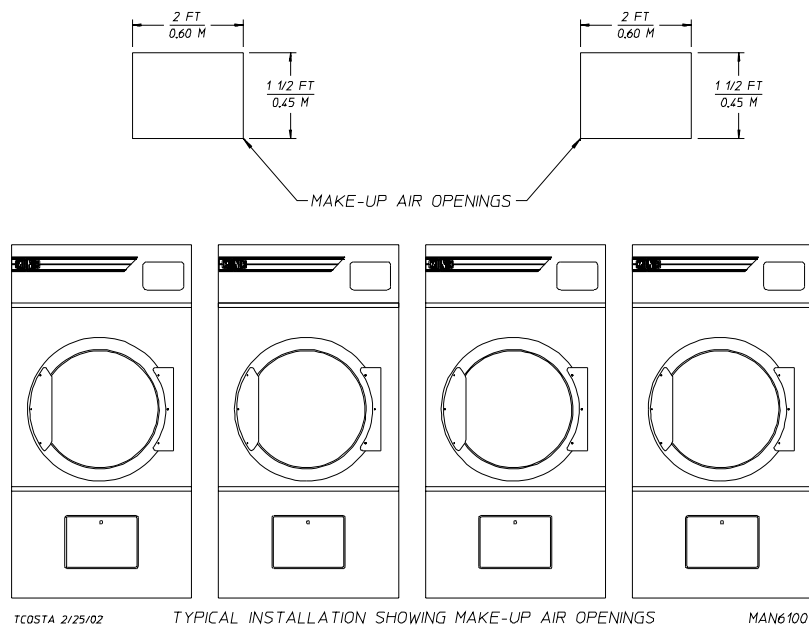

To compensate for the use of registers or louvers used over the openings, this make-up air **must be** increased by approximately thirty-three percent (33%). Make-up air openings **should not be** located in an area directly near where exhaust vents exit the building.

It is not necessary to have separate make-up air openings for each dryer. Common make-up air openings are acceptable. However, they **must be** set up in such a manner that the make-up air is distributed equally to ALL the dryers.

*EXAMPLE:* For a bank of four (4) dryers, two (2) unrestricted openings measuring 2 feet by 1-1/2 feet (0.60 meters by 0.45 meters) (6 square feet [0.56 square meters]) are acceptable.

Allowances **must be** made for remote or constricting passageways or where dryers are located at excessive altitudes or predominantly low pressure areas.

**IMPORTANT:** Make-up air **must be** provided from a source free of dry cleaning solvent fumes. Make-up air that is contaminated by dry cleaning solvent fumes will result in irreparable damage to the motors and other dryer components.

**NOTE:** Component failure due to dry cleaning solvent fumes will VOID THE WARRANTY.

## E. EXHAUST REQUIREMENTS

### 1. General Exhaust Ductwork Information

Exhaust ductwork **should be** designed and installed by a qualified professional. Improperly sized ductwork will create excessive back pressure which results in slow drying, increased use of energy, overheating of the dryer, and shutdown of the burner by the airflow (sail) switches, burner hi-limits, or basket (tumbler) hi-limit thermostats. The dryer **must be** installed with a proper exhaust duct connection to the outside.

**CAUTION:** This dryer produces combustible lint and *must be* exhausted to the outdoors.

**CAUTION:** DRYER *MUST BE* EXHAUSTED TO THE OUTDOORS.

**CAUTION: IMPROPERLY SIZED OR INSTALLED EXHAUST DUCTWORK CAN  
CREATE A POTENTIAL FIRE HAZARD.**

The ductwork **should be** laid out in such a way that the ductwork travels as directly as possible to the outdoors with as few turns as possible. Single or independent dryer venting is recommended.

#### Horizontal Venting:

When single dryer venting is used, the length of the ductwork from the dryer to the outside exhaust outlet **must not exceed** 15 feet (4.6 meters). The minimum diameter of this ductwork **must be** at least 10-inches (25.4 cm). In the case of multiple (common) dryer venting, the distance from the last dryer to the outside exhaust outlet **must not exceed** 15 feet (4.6 meters). The shape of the ductwork is not critical as long as the minimum cross-sectional area is provided. It is suggested that the use of 90° turns be avoided; use 30° and/or 45° angles instead. The radius of the elbows **should preferably be** 1-1/2 times the diameter of the duct. Including basket (tumbler)/dryer elbow connections or elbows used for outside protection from the weather, no more than two (2) elbows **should be** used in the exhaust duct run. If more than two (2) elbows are used, the cross-sectional area of the ductwork **must be** increased. **ALL** ductwork **should be** smooth inside with no projections from sheet metal screws or other obstructions, which will collect lint. When adding ducts, the duct to be added should overlap the duct to which it is to be connected. **ALL** ductwork joints **must be** taped to prevent moisture and lint from escaping into the building. Inspection doors **should be** installed at strategic points in the exhaust ductwork for periodic inspection and cleaning of lint from the ductwork.

#### Vertical Venting:

When single dryer venting is used, the length of the ductwork from the dryer to the outside exhaust outlet **must not exceed** 20 feet (6.1 meters). The minimum diameter of this ductwork **must be** at least 12-inches (30.48 cm). In the case of multiple (common) dryer venting, the distance from the last dryer to the outside exhaust outlet **must not exceed** 20 feet (6.1 meters). The shape of the ductwork is not critical as long as the minimum cross-sectional area is provided. It is suggested that the use of 90° turns be avoided; use 30° and/or 45° bends instead. The radius of the elbows **should preferably be** 1-1/2 times the diameter of the duct. **ALL** ductwork **should be** smooth inside with no projections from sheet metal screws or other obstructions, which will collect lint. When adding ducts, the duct to be added should overlap the duct to which it is to be connected. **ALL** ductwork joints **must be** taped to prevent moisture and lint from escaping into the building. Inspection doors **should be** installed at strategic points in the exhaust ductwork for periodic inspection and cleaning of lint from the ductwork.

**IMPORTANT:** It is recommended that exhaust or booster fans not be used in the exhaust ductwork system.

**NOTE:** As per the National Fuel Gas Code, “Exhaust ducts for Type 2 clothes dryers shall be constructed of sheet metal or other noncombustible material. Such ducts shall be equivalent in strength and corrosion resistance to ducts made of galvanized sheet steel not less than 0.0195-inches (26 gauge [0.05 mm]) thick.”

**IMPORTANT:** Exhaust back pressure measured by a manometer in the exhaust duct **must be** no less than 0 and **must not exceed** 0.3 inches (0.74 mb) of water column (W.C.).

**IMPORTANT:** Minimum ductwork diameter for horizontal venting is 10-inches (25.4 cm) and for vertical venting the minimum is 12-inches (30.48 cm).

**NOTE:** When the exhaust ductwork passes through a wall, ceiling, or roof made of combustible materials, the opening **must be** 2-inches (5.08 cm) larger than the duct (all the way around). The duct **must be** centered within this opening.

a. Outside Ductwork Protection

- 1) To protect the outside end of the horizontal ductwork from the weather, a 90° elbow bent downward **should be** installed where the exhaust exits the building. If the ductwork travels vertically up through the roof, it **should be** protected from the weather by using a 180° turn to point the opening downward. In either case, allow at least twice the diameter of the duct between the duct opening and the nearest obstruction.

**IMPORTANT:** **DO NOT** use screens, louvers, or caps on the outside opening of the exhaust ductwork.

VERTICAL DUCTING

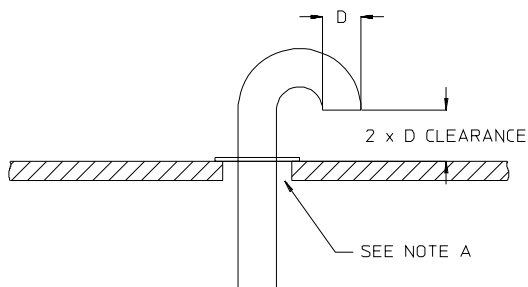

MAN4589

NOTE 'A': OPENING MUST BE TWO (2) INCHES (5.08 CM) LARGER THAN DUCT (ALL THE WAY AROUND). THE DUCT MUST BE CENTERED WITHIN THIS OPENING.

HORIZONTAL DUCTING

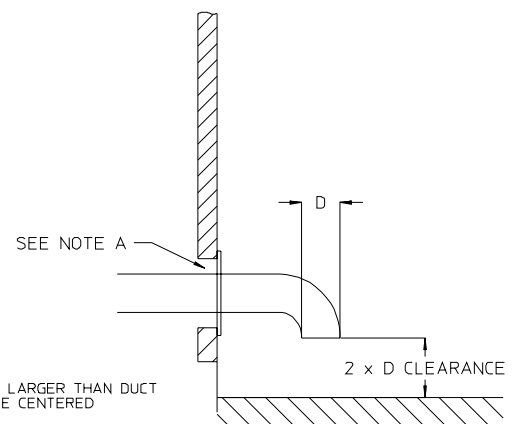

2. Single Dryer Venting

When possible, it is suggested to provide a separate exhaust duct for each dryer. The exhaust duct **should be** laid out in such a way that the ductwork travels as directly as possible to the outdoors with as few turns as possible. It is suggested that the use of 90° turns in the ducting be avoided; use 30° and/or 45° angles instead. The shape of the exhaust ductwork is not critical as long as the minimum cross-sectional area is provided.

**IMPORTANT:** Minimum duct size for a dryer that is vented horizontally is 10-inches (25.4 cm) for a round duct or an equivalent of 80 square inches (516.3 square centimeters). **THE DUCT SIZE *MUST NOT BE REDUCED ANYWHERE DOWNSTREAM OF THE DRYER.***

**IMPORTANT:** Exhaust back pressure measured by a manometer in the exhaust duct *must be* no less than 0 and *must not exceed* 0.3 inches (0.74 mb) of water column.

**IMPORTANT:** Minimum duct size for a dryer that is vented vertically is 12-inches (30.48 cm) for a round duct or an equivalent of 120 square inches (774.2 square centimeters). **THE DUCT SIZE *MUST NOT BE REDUCED ANYWHERE DOWNSTREAM OF THE DRYER.***

### SINGLE DRYER VENTING

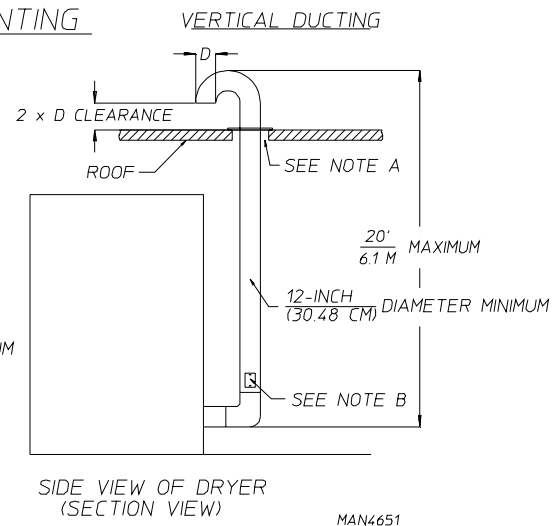
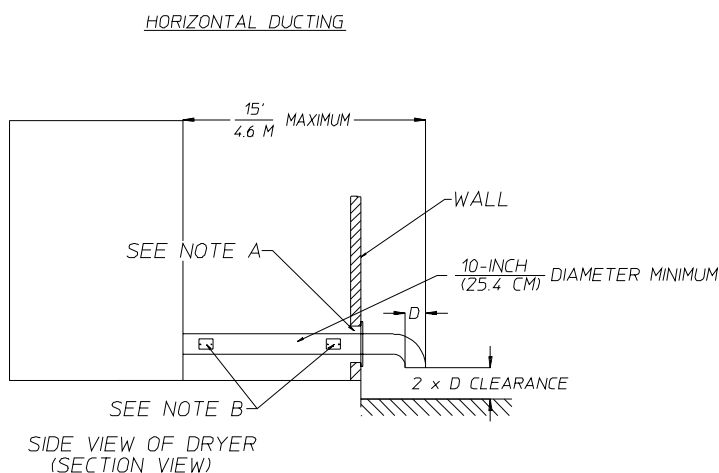

NOTE: "A"- OPENING MUST BE TWO (2) INCHES (5.08 CM) LARGER THAN DUCT (ALL THE WAY AROUND). THE DUCT MUST BE CENTERED WITHIN THIS OPENING.

"B"- INSPECTION DOORS SHOULD BE INSTALLED AT STRATEGIC POINTS FOR PERIODIC INSPECTION AND CLEANING

**IMPORTANT:** For extended ductwork runs, the cross section area of the ductwork can only be increased to an extent. When the ductwork approaches the maximum limits noted in this manual, a professional heating, ventilating, and air-conditioning (HVAC) firm *should be* consulted for proper venting information.

**ALL** ductwork **should be** smooth inside with no projections from sheet metal screws or other obstructions, which will collect lint. When adding ducts, the duct to be added should overlap the duct to which it is to be connected. **ALL** ductwork joints **must be** taped to prevent moisture and lint from escaping into the building. Inspection doors **should be** installed at strategic points in the exhaust ductwork for periodic inspection and cleaning of lint from the ductwork.

**NOTE:** When the exhaust ductwork passes through a wall, ceiling, or roof made of combustible materials, the opening **must be** 2-inches (5.08 cm) larger than the duct (all the way around). The duct **must be** centered within this opening.

a. Outside Ductwork Protection

- 1) To protect the outside end of the horizontal ductwork from the weather, a 90° elbow bent downward **should be** installed where the exhaust exits the building. If the ductwork travels vertically up through the roof, it **should be** protected from the weather by using a 180° turn to point the opening downward. In either case, allow at least twice the diameter of the duct between the duct opening and the nearest obstruction.

**IMPORTANT: DO NOT** use screens, louvers, or caps on the outside opening of the exhaust ductwork.

MULTIPLE DRYER VENTING (MLG-78) WITH 10" (25.4 CM) DIAMETER (1200 CFM [34CMM]) EXHAUST CONNECTIONS AT COMMON DUCT

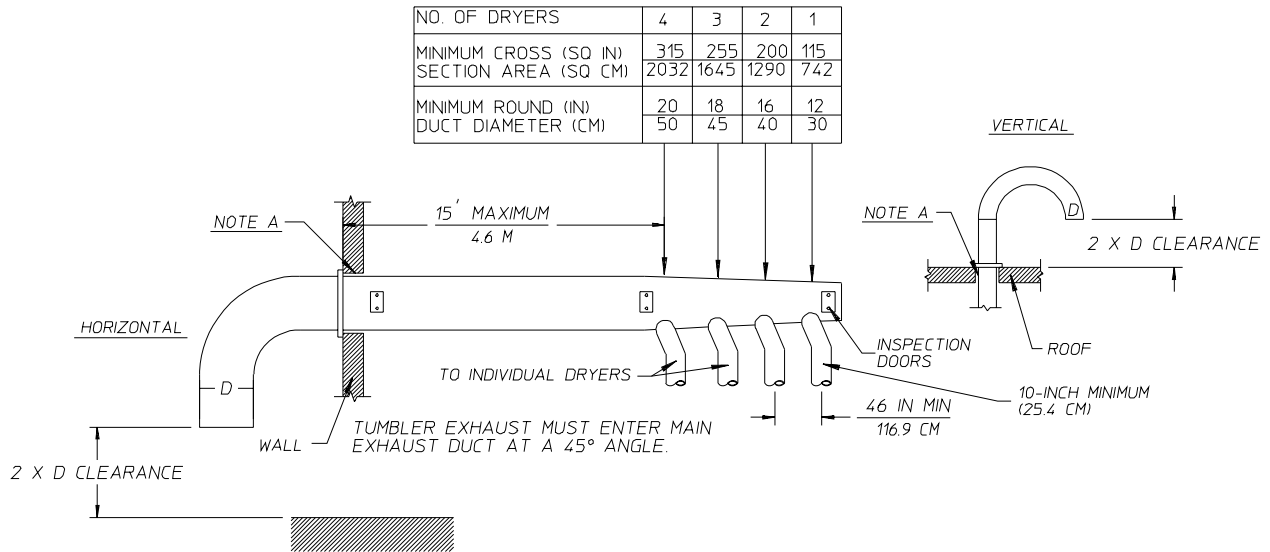

IMPORTANT: NO MORE THAN 4 DRYERS CAN BE CONNECTED TO ONE COMMON DUCT ( VENT ).

FORMULAS TO CALCULATE DUCTING CROSS SECTIONAL AREA

CROSS SECTIONAL AREA OF A ROUND DUCT = .785 (19,939 mm) x D<sup>2</sup> WHERE D = DIAMETER OF THE DUCT.

CROSS SECTIONAL AREA OF A RECTANGULAR DUCT = W x H WHERE W = WIDTH AND H = HEIGHT.

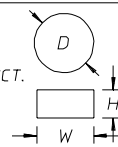

TC 03/10/00

NOTE A: OPENING MUST BE 2-INCHES (5.08 CM) LARGER THAN DUCT (ALL THE WAY AROUND). THE DUCT MUST BE CENTERED WITHIN THIS OPENING.

MAN5105

## F. ELECTRICAL INFORMATION

### 1. Electrical Requirements

**ALL electrical connections must be made by a properly licensed and competent electrician.** This is to ensure that the electrical installation is adequate and conforms to local and state regulations or codes. In the absence of such codes, **ALL** electrical connections, materials, and workmanship **must conform** to the applicable requirements of the National Electrical Code ANSI/NFPA NO. 70-LATEST EDITION or in Canada, the Canadian Electrical Codes Parts 1 & 2 CSA C22.1-1990 or LATEST EDITION.

**IMPORTANT:** Failure to comply with these codes or ordinances, and/or the requirements stipulated in this manual can result in personal injury or component failure.

**NOTE:** Component failure due to improper installation will VOID THE WARRANTY.

Each dryer **should be** connected to an independently protected branch circuit. The dryer **must be** connected with copper wire only. ***DO NOT use aluminum wire, which could cause a fire hazard.*** The copper conductor wire/cable **must be** of proper ampacity and insulation in accordance with electric codes for making **ALL** service connections.

**NOTE:** The use of aluminum wire will VOID THE WARRANTY.

**IMPORTANT:** A separate protected circuit ***must be*** provided to each dryer.

**NOTE:** An individual ground circuit must be provided to each dryer, do not daisy chain.

**IMPORTANT:** The dryer ***must be*** connected to the electric supply shown on the data label. In the case of 208 VAC or 230/240 VAC, the supply voltage must match the electric service specifications of the data label **exactly**.

**IMPORTANT:** The wire size ***must be*** properly sized to handle the related current.

**WARNING:** **208 VAC AND 230/240 VAC ARE NOT THE SAME**. Any damage done to dryer components due to improper voltage connections will automatically VOID THE WARRANTY.

**NOTE:** Component failure due to improper voltage application will VOID THE WARRANTY.

**NOTE:** ADC reserves the right to make changes in specifications at any time without notice or obligation.

## 2. Electrical Service Specifications

**IMPORTANT:** Figures shown are for non-reversing models only. For reversing models contact the factory.

# GAS MODELS

## ELECTRICAL SERVICE SPECIFICATIONS (PER DRYER)

**IMPORTANT:** 208 VAC AND 230/240 VAC **ARE NOT THE SAME.** When ordering, *specify exact voltage.*

- NOTES:**
- A. When fuses are used they **must be** dual element, time delay, current limiting, class RK1 or RK5 **ONLY.** Calculate/determine correct fuse value, by applying either local and/or National Electrical Codes to listed appliance amp draw data.
  - B. Circuit breakers are thermal-magnetic (industrial) motor curve type **ONLY.** For others, calculate/verify correct breaker size according to appliance amp draw rating and type of breaker used.
  - C. Circuit breakers for 3-phase (3Ø) dryers **must be** 3-pole type.

SERVICE VOLTAGE	PHASE	WIRE SERVICE	APPROX. AMP DRAW		MINIMUM WIRE SIZE	FUSING Dual Element Time Delay	CIRCUIT BREAKER
			60 Hz	50 Hz			
120	1Ø	2	13	---	*	20	20
208	1Ø	2	7.6	---	*	15	15
230/240	1Ø	2	7	7.8	*	15	15
208	3Ø	3	4.7	---	*	15	15
230/240	3Ø	3	4.9	5.7	*	15	15
380	3Ø	4**	---	2.9	*	15	15
400	3Ø	4**	---	3	*	15	15
416	3Ø	4**	---	3.1	*	15	15
460/480	3Ø	3	2.8	---	*	15	15

\* AWG Stranded Wire Type...size wire as per National Electrical Code or local codes.

9/23/03

\*\* Dryers are built 4-wire. Customer must contact factory to special order 3-wire.

## 3. Grounding

A ground (earth) connection **must be** provided and installed in accordance with state and local codes. In the absence of these codes, grounding **must conform** to applicable requirements of the National Electrical Code ANSI/NFPA NO. 70-LATEST EDITION, or in Canada, the installation **must conform** to applicable Canada Standards: Canadian Electrical Codes Parts 1 & 2 CSA C22.1-1990 or LATEST EDITION. The ground connection may be to a proven earth ground at the location service panel.

For added personal safety, when possible, it is suggested that a separate ground wire (no. 18 minimum) be connected from the ground connection of the dryer to a grounded cold water pipe. **DO NOT ground to a gas pipe or hot water pipe.** The grounded cold water pipe must have metal-to-metal connection **ALL** the way to the electrical ground. If there are any nonmetallic interruptions, such as, a meter, pump, plastic, rubber, or other insulating connectors, they **must be** jumped out with no. 4 copper wire and securely clamped to bare metal at both ends.

**IMPORTANT:** For personal safety and proper operation, the dryer **must be** grounded.

Provisions are made for ground connection in each dryer at the electrical service connection area.

#### 4. Electrical Connections

A wiring diagram is located inside the control box for connection data.

If local codes permit, power to the dryer can be made by the use of a flexible U.L. listed power cord/pigtail (wire size **must conform** to rating of dryer), or the dryer can be hard wired directly to the service breaker panel. In both cases, a strain relief **must be** installed where the wiring enters the dryer.

**IMPORTANT:** A separate protected circuit **must be** provided to each dryer.

##### a. Single-Phase (1 $\phi$ ) Wiring Connections/Hookup

The electrical input connections on **ALL** single-phase (1 $\phi$ ) gas dryers and steam dryers are made into the rear service box located at the upper left area of the dryer.

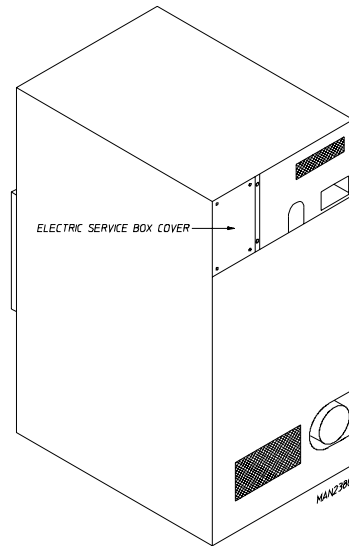

Single-Phase Electrical Lead Connections		
Black + Positive	White or Red + Neutral or L2	Green + Ground

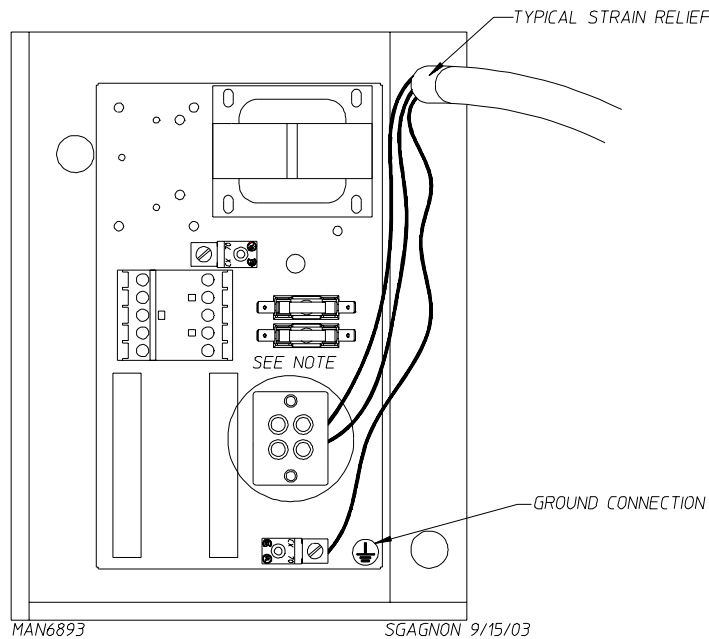



## FOR 110V APPLICATIONS

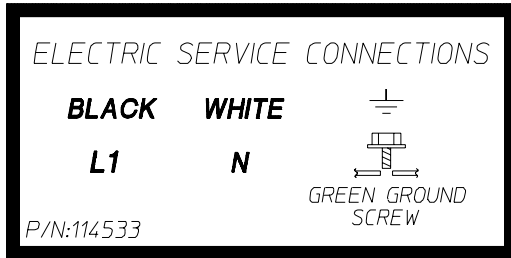

MAN6886

SGAGNON 9/15/03

## FOR 208-230/240V APPLICATIONS

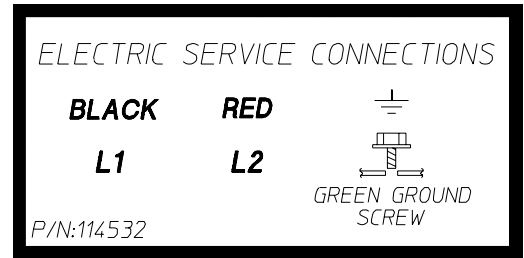

MAN6887

SGAGNON 9/15/03

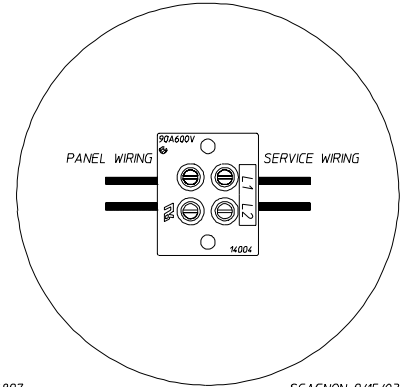
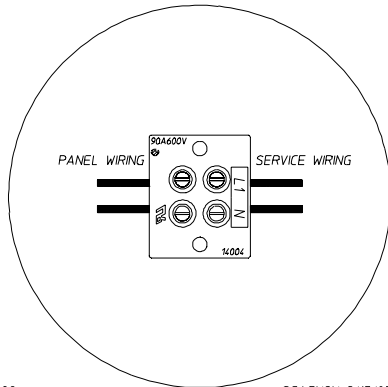

A ground lug is provided in the rear electrical box to connect your service ground.

### b. 3-Phase (3 $\phi$ ) Wiring Connections/Hookup

The electrical connections on **ALL** 3-phase (3 $\phi$ ) gas and steam dryers are made into the rear service box located at the upper left area of the dryer. The electrical connections are made at the power distribution block located in the service box. The ground connection is made to the copper lug, also provided in this box. To gain access, the service box cover **must be** removed.

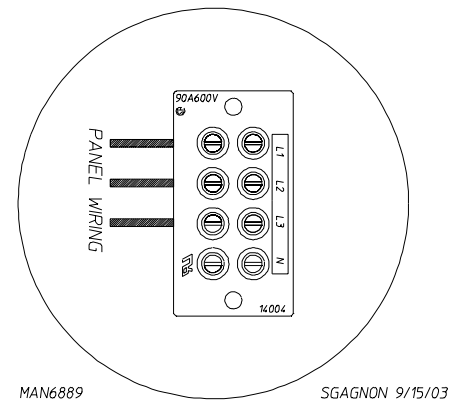
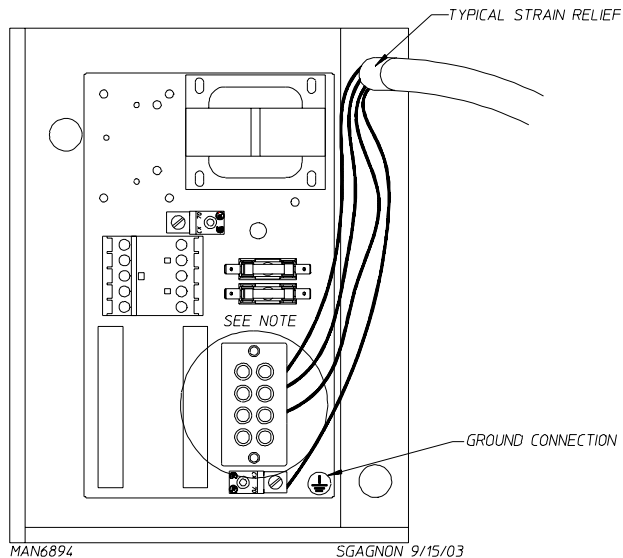

The neutral will only be used on 4-wire service. This is typical for 380-416V, 50 Hz.

## G. GAS INFORMATION

It is your responsibility to have **ALL** plumbing connections made by a qualified professional to ensure that the gas plumbing installation is adequate and conforms to local and state regulations or codes. In the absence of such codes, **ALL** plumbing connections, materials, and workmanship **must conform** to the applicable requirements of the National Fuel Gas Code ANSI Z223.1-LATEST EDITION, or in Canada, the Canadian Installation Codes CAN/CGA-B149.1-M91 (Natural Gas) or CAN/CGA-B149.2-M91 (Liquid Propane [L.P.] Gas) or LATEST EDITION.

**IMPORTANT:** Failure to comply with these codes or ordinances, and/or the requirements stipulated in this manual, can result in personal injury and improper operation of the dryer.

The dryer and its individual shutoff valves **must be** disconnected from the gas supply piping system during any pressure testing of that system at test pressures in excess of 1/2 psig (3.5 kPa). The dryer **must be** isolated from the gas supply piping system by closing its individual manual shutoff valve during any pressure test of the gas supply system at test pressures equal to or less than 1/2 psig (3.5 kPa).

**IMPORTANT:** Failure to isolate or disconnect dryer from supply as noted can cause irreparable damage to the gas valve, which will VOID THE WARRANTY.

**WARNING: FIRE OR EXPLOSION COULD RESULT.**

### 1. Gas Supply

The gas dryer installation **must meet** the American National Standard...National Fuel Gas Code ANSI Z223.1-LATEST EDITION, or in Canada, the Canadian Installation Codes CAN/CGA-B149.1 M91 (Natural Gas) or CAN/CGA-B149.2-M91 (L.P. Gas) or LATEST EDITION, as well as local codes and ordinances and **must be** done by a qualified professional.

**NOTE:** Undersized gas piping will result in ignition problems, slow drying, increased use of energy, and can create a safety hazard.

The dryer **must be** connected to the type of heat/gas indicated on the dryer data label. If this information does not agree with the type of gas available, **DO NOT operate the dryer**. Contact the reseller who sold the dryer or contact the **ADC** factory.

**IMPORTANT:** Any burner changes or conversions **must be** made by a qualified professional.

The input ratings shown on the dryer data label are for elevations up to 2,000 feet (610 meters), unless elevation requirements of over 2,000 feet (610 meters) were specified at the time the dryer order was placed with the factory. The adjustment or conversion of dryers in the field for elevations over 2,000 feet (610 meters) is made by changing each burner orifice. If this conversion is necessary, contact the reseller who sold the dryer or contact the **ADC** factory.

**IMPORTANT:** THIS GAS DRYER **IS NOT** PROVIDED WITH AN INTERNAL GAS SUPPLY SHUTOFF AND AN EXTERNAL GAS SUPPLY SHUTOFF **MUST BE** PROVIDED.

2. Technical Gas Data

a. Gas Specifications

<b>TYPE OF GAS</b>				
	NATURAL		LIQUID PROPANE	
Manifold Pressure*	3.5 inches W.C.	8.7 mb	10.5 inches W.C.	26.1 mb
In-Line Pressure	6.0 - 12.0 inches W.C.	14.92 - 29.9 mb	11.0 inches W.C.	27.4 mb

*Shaded areas are stated in metric equivalents*

\* Measured at the gas valve pressure tap when the gas valve is on.

b. Gas Connections

- Inlet connection ----- 3/4" N.P.T.
- Inlet supply size ----- 3/4" N.P.T. (minimum)
- Btu/hr input ----- 204,000 (51,408 kcal/hr)

1) Natural Gas

Regulation is controlled by the dryer's gas valve's internal regulator. Incoming supply pressure **must be** consistent between a minimum of 6.0 inches (14.92 mb) and a maximum of 12.0 inches (29.9 mb) water column (W.C.) pressure.

2) Liquid Propane (L.P.) Gas

Dryers made for use with L.P. gas have the gas valve's internal pressure regulator blocked open so that the gas pressure **must be** regulated upstream of the dryer. The pressure measured at each gas valve pressure tap **must be** a consistent 10.5 inches (26.1 mb) water column. There is no regulator or regulation provided in an L.P. dryer. The water column pressure **must be** regulated at the source (L.P. tank) or an external regulator **must be** added to each dryer.

		<b>TYPE OF GAS</b>						Liquid Propane Conversion Kit Part Number
Btu/hr Rating	kcal/hr Rating	Natural			Liquid Propane			
		Qty.	D.M.S.*	Part No.	Qty.	D.M.S.*	Part No.	
204,000	51,408	3	#23	140856	3	#42	140810	881655

*Shaded area is stated in metric equivalent*

\* Drill Measurement Size (D.M.S.) equivalents are as follows:

- Natural Gas ..... #23 = 0.1540" (3.9116 mm).
- Liquid Propane Gas ..... #42 = 0.0935" (2.3749 mm).

### 3. Piping/Connections

**ALL** components/materials **must conform** to National Fuel Gas Code Specifications ANSI Z223.1-LATEST EDITION, or in Canada, CAN/CGA-B149.1-M91 (Natural Gas) or CAN/CGA-B149.2-M91 (Liquid Propane [L.P.] Gas) or LATEST EDITION (for General Installation and Gas Plumbing), as well as local codes and ordinances and **must be** done by a qualified professional. It is important that gas pressure regulators meet applicable pressure requirements, and that gas meters be rated for the total amount of **ALL** the appliance Btus being supplied.

The dryer is provided with a 3/4" N.P.T. inlet pipe connection located at the right side of the base of the dryer. The minimum pipe size (supply line) to the dryer is 3/4" N.P.T. For ease in servicing, the gas supply line of each dryer must have its own shutoff valve.

The size of the main gas supply line (header) will vary depending on the distance this line travels from the gas meter or, in the case of L.P. gas, the supply tank, other gas-operated appliances on the same line, etc. Specific information regarding supply line size **should be** determined by the gas supplier.

**NOTE:** Undersized gas supply piping can create a low or inconsistent pressure, which will result in erratic operation of the burner ignition system.

TYPICAL NATURAL GAS INSTALLATION

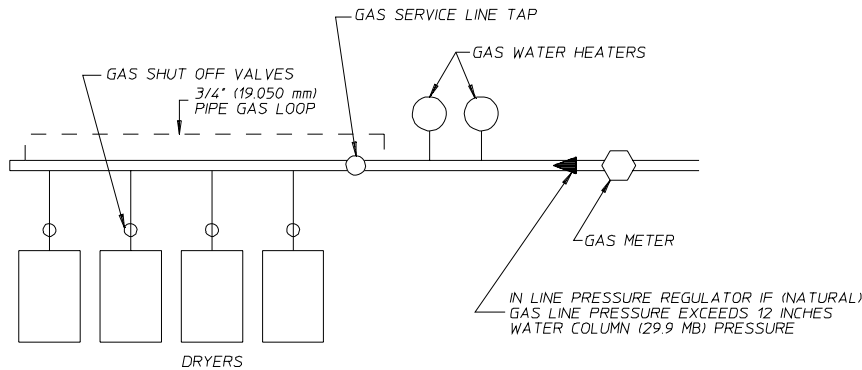

TYPICAL L.P. GAS INSTALLATION

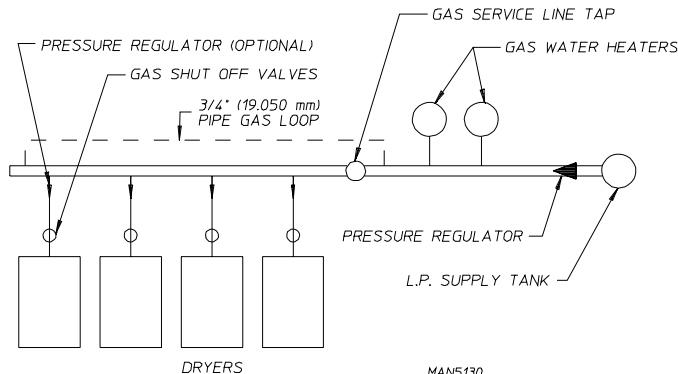

MAN5130

Consistent gas pressure is essential at **ALL** gas connections. It is recommended that a 3/4-inch (19.050 mm) pipe gas loop be installed in the supply line servicing a bank of dryers. An in-line pressure regulator **must be** installed in the gas supply line (header) if the (natural) gas pressure exceeds 12.0 inches (29.9 mb) of water column (W.C.) pressure.

**NOTE:** A water column test pressure of 3.5 inches (8.7 mb) for natural gas and 10.5 inches (26.1 mb) for liquid propane (L.P.) dryers is required at the gas valve pressure tap of each dryer for proper and safe operation.

A 1/8" N.P.T. plugged tap, accessible for a test gauge connection, **must be** installed in the main gas supply line immediately upstream of each dryer.

**IMPORTANT:** Pipe joint compounds that resist the action of natural gas and L.P. gas **must be** used.

**IMPORTANT:** Test **ALL** connections for leaks by brushing on a soapy water solution (liquid detergent works well).

**WARNING: NEVER TEST FOR LEAKS WITH A FLAME!!!**

**ALL** components/materials **must conform** to National Fuel Gas Code Specifications ANSI Z223.1-LATEST EDITION, or in Canada, CAN/CGA-B149.1-M91 (Natural Gas) or CAN/CGA-B149.2-M91 (L.P. Gas) or LATEST EDITION (for General Installation and Gas Plumbing), as well as local codes and ordinances and **must be** done by a qualified professional. It is important that gas pressure regulators meet applicable pressure requirements, and that gas meters be rated for the total amount of **ALL** the appliance BTUs being supplied.

**IMPORTANT:** The dryer and its individual shutoff valve **must be** disconnected from the gas supply piping system during any pressure testing of that system at test pressures in excess of 1/2 psig (3.5 kPa).

**NOTE:** The dryer **must be** isolated from the gas supply piping system by closing its individual manual shutoff valve during any pressure test of the gas supply system at test pressures equal to or less than 1/2 psig (3.5 kPa).

## H. PREPARATION FOR OPERATION/START-UP

The following items **should be** checked before attempting to operate the dryer:

1. Read **ALL** “**CAUTION,**” “**WARNING,**” and “**DIRECTION**” labels attached to the dryer.
2. Check incoming supply voltage to be sure that it is the same as indicated on the dryer data label. In the case of 208 VAC or 230/240 VAC the supply voltage must match the electric service **exactly**.
3. Check to ensure that the dryer is connected to the type of heat/gas indicated on the dryer data label.
4. The sail switch damper assembly was installed and pre-adjusted at the factory prior to shipping. However, each sail switch adjustment **must be** checked to ensure that this important safety control is functioning.
5. Be sure that **ALL** gas shutoff valves are in the open position.
6. Be sure **ALL** back panels (guards) and electric box covers have been replaced.
7. Check **ALL** service doors to ensure that they are closed and secured in place.
8. Be sure the lint door is securely in place.
9. Rotate the basket (tumbler/drum) by hand to be sure it moves freely.
10. Check bolts, nuts, screws, terminals, and fittings for security.
11. Check basket (tumbler) bearing setscrews to ensure they are **ALL** tight.

## I. PREOPERATIONAL TESTS

**ALL** dryers are thoroughly tested and inspected before leaving the factory. However, a preoperational test **should be** performed before the dryer is publicly used. It is possible that adjustments have changed in transit or due to marginal location (installation) conditions.

1. Turn on electric power to the dryer.
  - a. Open **ALL** shutoff valves.
2. Refer to the Operating Instructions for starting your particular model dryer.
  - a. When the dryer is first started (during initial start-up), the burner has a tendency not to ignite on the first attempt. This is because the gas supply piping is filled with air, so it may take a few minutes for this air to be purged from the lines.
  - b. A gas pressure test **should be** taken at the gas valve pressure tap of each dryer to ensure that the water column (W.C.) pressure is correct and consistent.
  - c. If the dryer is equipped with a Direct Spark Ignition (DSI) system, the DSI control module has internal diagnostics. If ignition is not established within three (3) attempts, the heat circuit in the DSI control module will “LOCKOUT” until manually reset. To reset the DSI system, open and close the main door and restart the dryer.

**NOTE:** During the purging period, check to be sure that **ALL** gas shutoff valves are open.

**NOTE:** Water column pressure requirements (measured at the pressure tap of the gas valve body)...

Natural Gas ----- 3.5 Inches (8.7 mb) Water Column.  
Liquid Propane (L.P.) Gas ---- 10.5 Inches (26.1 mb) Water Column.

**IMPORTANT:** There is no regulator provided in an L.P. dryer. The water column pressure **must be** regulated at the source (L.P. tank), or an external regulator **must be** added to each dryer.

3. Make a complete operational check of **ALL** safety related circuits:
  - a. Door switch(es)
  - b. Hi-Limit thermostats
  - c. Sail switch

**NOTE:** To check for proper sail switch operation, open the main door and while holding main door switch plunger in, start the dryer. Dryer should start but heat circuit **should not be** activated (on). If the heat system is activated, the sail switch is improperly adjusted and **must be** adjusted by bending the actuator arm of the sail switch toward the burner box. If the actuator arm is bent to far toward the burner box of the dryer, the dryer **may not** have heat when needed. After any adjustment to the sail switch, the above procedure **must be** repeated to verify proper operation of the sail switch.

4. The dryer **should be** operated through one (1) complete cycle to ensure that no further adjustments are necessary and that **ALL** components are functioning properly.

### BASKET (TUMBLER) COATING

The basket (tumbler) is treated with a protective coating. We suggest dampening old garments or cloth material with a solution of water and nonflammable mild detergent and tumbling them in the basket (tumbler) to remove this coating.

5. Make a complete operational check of **ALL** operating controls.
  - a. For microprocessor controller (computer) models check programs/selections...
    - 1) Each microprocessor controller (computer) has been preprogrammed by the factory with the most commonly used parameter (program) selections. If computer program changes are required, refer to the computer programming manual, which was shipped with the dryer.
6. Check the electric service phase sequence (3-phase [3 $\phi$ ] models only). While the dryer is operating, check to see if the blower wheel (impellor/fan) is rotating in the proper direction. Looking from the front, the blower wheel (impellor/fan) should spin in the clockwise (CW) direction. If it is, the phasing is correct. If the phasing is incorrect, reverse two (2) of the three (3) leads at connections L1, L2, and L3 of the power supply to the dryer.

**IMPORTANT:** If the blower wheel (impellor/fan) is rotating in the wrong direction, this **will not** only drastically reduce drying efficiency, but it can also cause premature component failure.

7. Reversing basket (tumbler) dryers **should never be** operated with less than a 50 lb (22.7 kg) load (dry weight), since the load's weight effects the basket (tumbler) coast time during a direction reversal command. It is important that the basket (tumbler) comes to a complete stop prior to starting in opposite direction.
  - a. Microprocessor Models
    - 1) Spin times and dwell (stop) times are not adjustable in the Automatic Mode and have been preprogrammed into the microprocessor controller (computer) for 120-seconds spin time and a 5-second dwell (stop) time.
    - 2) Spin times and dwell (stop) times are adjustable in the Manual (timed) Mode.
  - b. Dual Timer Models
    - 1) Both dwell (stop) time and basket (tumbler) spin time are adjustable (refer to the **illustration on page 35**).
8. Check to ensure that **ALL** setscrews (i.e., basket [tumbler] drive, idler, etc.) are tight.



## J. PREOPERATIONAL INSTRUCTIONS

1. To start the dryer:
  - a. Microprocessor Controller (Computer) Dryers...
    - 1) The light emitting diode (L.E.D.) display will read "REAdY" (meaning no cycle in progress).
    - 2) Press the letter on the keyboard (touch pad) corresponding to the cycle desired (i.e., key "E")...
      - a) The dryer will then start (rotate).
    - 3) L.E.D. display will now show "Cycle In Progress" and "Cycle Status" meaning that the dryer is in the drying cycle (dry mode for 30 minutes) and count downwards in minutes.

**NOTE:** Pressing keyboard (touch pad) key "A," "B," "C," "D," or "F" will also start the dryer. The six (6) preprogrammed drying cycles "A" through "F" have been stored in the microprocessor controller (computer) memory. Refer to the Programming Manual supplied with the dryer for more specific operating instructions.

**NOTE:** The dryer can be stopped at any time by opening the main door or by pressing the  red key. To restart the dryer, press the  green key or a preprogrammed cycle key (i.e., "E").

**NOTE:** Selection (settings) changes can be made at any time during the drying cycle by pressing the  red key twice. The L.E.D. display will return to "REAdY" at which time a new cycle selection can be made.

### b. Dual Timer Dryers

- 1) Turn drying timer knob for a time of 20 minutes.
- 2) Select drying temperature.
- 3) Push "Start" button.
- 4) To stop dryer, open the main door.

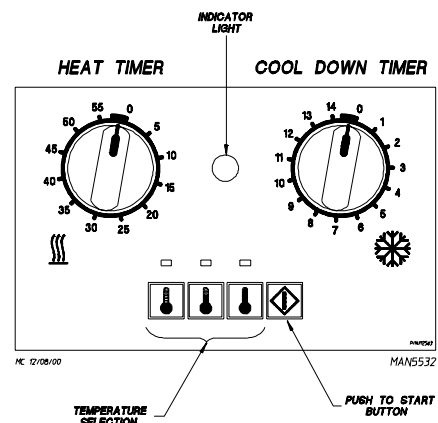

## K. SHUTDOWN INSTRUCTIONS

If the dryer is to be shutdown (taken out of service) for a period of time, the following **must be** performed:

1. Discontinue power to the dryer either at the external disconnect switch or the circuit breaker.
2. Discontinue the heat supply:
  - a. **GAS MODELS...discontinue the gas supply.**
    - 1) **SHUT OFF external gas supply shutoff valve.**

# SECTION IV

## SERVICE/PARTS INFORMATION

### A. SERVICE

1. Service **must be** performed by a qualified trained technician, service agency, or gas supplier. If service is required, contact the reseller from whom the **ADC** equipment was purchased. If the reseller **cannot** be contacted or is unknown, contact the **ADC** Service Department for a reseller in your area.

**NOTE:** When contacting the **ADC** Service Department, be sure to give them the correct **model number** and **serial number** so that your inquiry is handled in an expeditious manner.

### B. PARTS

1. Replacement parts **should be** purchased from the reseller from whom the **ADC** equipment was purchased. If the reseller **cannot** be contacted or is unknown, contact the **ADC** Parts Department for a reseller in your area. Parts may also be purchased directly from the factory by calling the **ADC** Parts Department at (508) 678-9000 or you may FAX in your order at (508) 678-9447.

**NOTE:** When ordering replacement parts from the **ADC** reseller or the **ADC** factory be sure to give them the correct **model number** and **serial number** so that your parts order can be processed in an expeditious manner.

# SECTION V

## WARRANTY INFORMATION

### A. RETURNING WARRANTY CARDS

1. Before any dryer leaves the **ADC** factory test area, a warranty card is placed on the back side of the main door glass. These warranty cards are intended to serve the customer where we record the individual installation date and warranty information to better serve you should you file a warranty claim.
  - a. If a warranty card did not come with your dryer, contact the **ADC** Warranty Department or the **ADC** Service Department at (508) 678-9000.

**IMPORTANT:** A separate warranty card *must be* completed and returned for each individual dryer.

**NOTE:** Be sure to include the installation date when returning the warranty card(s).

### B. WARRANTY

For a copy of the **ADC** commercial warranty covering your particular dryer(s), contact the **ADC** reseller from whom you purchased the equipment and request a dryer warranty form. If the reseller **cannot** be contacted or is unknown, warranty information can be obtained from the factory by contacting the **ADC** Warranty Department at (508) 678-9000.

**NOTE:** Whenever contacting the **ADC** factory for warranty information, be sure to have the dryer's **model number** and **serial number** available so that your inquiry can be handled in an expeditious manner.

### C. RETURNING WARRANTY PARTS

**ALL** dryer or parts warranty claims or inquiries **should be** addressed to the **ADC** Warranty Parts Department. To expedite processing, the following procedures **must be** followed:

1. No parts are to be returned to **ADC** without prior written authorization (“Return Material Authorization” [R.M.A.]) from the factory.

**NOTE:** An R.M.A. is valid for only thirty (30) days from date of issue.

- a. The R.M.A. issued by the factory, as well as any other correspondence pertaining to the returned part(s), **must be** included inside the package with the failed merchandise.

2. Each part **must be** tagged with the following information:
  - a. **Model number** and **serial number** of the dryer from which part was removed.
  - b. Nature of failure (be specific).
  - c. Date of dryer installation.
  - d. Date of part failure.
  - e. Specify whether the part(s) being returned is for a replacement, a credit, or a refund.

**NOTE:** If a part is marked for a credit or a refund, the invoice number covering the purchase of the replacement part **must be** provided.

**NOTE:** Warranty tags (ADC Part No. 450064) are available at “no charge” from ADC upon request.

3. The company returning the part(s) must clearly note the complete company name and address on the outside of the package.
4. **ALL** returns **must be** properly packaged to ensure that they are not damaged in transit. *Damage claims are the responsibility of the shipper.*

**IMPORTANT:** No replacements, credits, or refunds **will be** issued for merchandise damaged in transit.

5. **ALL** returns **should be** shipped to the ADC factory in such a manner that they are insured and a proof of delivery can be obtained by the sender.
6. **Shipping charges are not the responsibility of ADC. ALL returns should be “prepaid” to the factory. Any “C.O.D.” or “COLLECT” returns will not be accepted.**

**IMPORTANT:** No replacements, credits, or refunds **will be** issued if the claim **cannot** be processed due to insufficient information. The party filing the claim **will be** notified in writing, either by “FAX” or “CERTIFIED MAIL - Return Receipt Requested,” as to the information necessary to process claim. If reply **is not** received by the ADC Warranty Department within thirty (30) days from the FAX/letter date, then no replacements, credits, or refunds **will be** issued, and the merchandise **will be** discarded.

# SECTION VI

## ROUTINE MAINTENANCE

### A. CLEANING

A program and/or schedule **should be** established for periodic inspection, cleaning, and removal of lint from various areas of the dryer, as well as throughout the ductwork system. The frequency of cleaning can best be determined from experience at each location. Maximum operating efficiency is dependent upon proper air circulation. The accumulation of lint can restrict this airflow. If the guidelines in this section are met, an ADC dryer will provide many years of efficient, trouble free, and most importantly, safe operation.

**WARNING: LINT FROM MOST FABRICS IS HIGHLY COMBUSTIBLE. THE ACCUMULATION OF LINT CAN CREATE A POTENTIAL FIRE HAZARD.**

**WARNING: KEEP DRYER AREA CLEAR AND FREE FROM COMBUSTIBLE MATERIALS, GASOLINE, AND OTHER FLAMMABLE VAPORS AND LIQUIDS.**

**NOTE:** Suggested time intervals shown are for average usage which is considered six (6) to eight (8) operational (running) hours per day.

**IMPORTANT:** Dryer produces combustible lint and *must be* exhausted to the outdoors. Every 6 months, inspect the exhaust ducting and remove any lint buildup.

### SUGGESTED CLEANING SCHEDULE

#### ***EVERY THIRD OR FOURTH LOAD***

Clean the lint screen every third or fourth load. A clogged lint screen will cause poor dryer performance. The lint screen is located behind the lint door in the base of the dryer. Open the lint door, brush the lint off the lint screen, and remove the lint. Inspect the lint screen and replace if torn.

**NOTE:** The frequency of cleaning the lint screens can best be determined from experience at each location.

#### ***WEEKLY***

Clean lint accumulation from the lint chamber, thermostat, and microprocessor temperature sensor (sensor bracket) area.

**WARNING: TO AVOID HAZARD OF ELECTRICAL SHOCK, DISCONTINUE ELECTRICAL POWER SUPPLY TO THE DRYER.**

## **90 DAYS**

1. Remove lint from around basket (tumbler), drive motors, and surrounding areas.
2. Remove lint from gas valve burner area with a dusting brush or vacuum cleaner attachment.
3. Clean any lint accumulation in and around both the blower and drive motor casing openings.

**NOTE:** To prevent damage, avoid cleaning or touching the hot surface ignitor assembly.

## **EVERY 6 MONTHS**

Inspect and remove lint accumulation in customer furnished exhaust ductwork system and from dryer's internal exhaust ducting.

**NOTE: THE ACCUMULATION OF LINT IN THE EXHAUST DUCTWORK CAN CREATE A POTENTIAL FIRE HAZARD.**

**NOTE: DO NOT OBSTRUCT THE FLOW OF COMBUSTION AND VENTILATION AIR. CHECK CUSTOMER FURNISHED BACK DRAFT DAMPERS IN THE EXHAUST DUCTWORK. INSPECT AND REMOVE ANY LINT ACCUMULATION, WHICH CAN CAUSE THE DAMPER TO BIND OR STICK.**

**NOTE:** A back draft damper that is sticking partially closed can result in slow drying and shutdown of heat circuit safety switches or thermostats.

**NOTE:** When cleaning the dryer cabinet(s), avoid using harsh abrasives. A product intended for the cleaning of appliances is recommended.

## **B. ADJUSTMENTS**

### **7 DAYS AFTER INSTALLATION AND EVERY 6 MONTHS THEREAFTER**

Inspect bolts, nuts, screws, (bearing setscrews), grounding connections, and nonpermanent gas connections (unions, shutoff valves, and orifices). Motor and drive belts **should be** examined. Cracked or seriously frayed belts **should be** replaced. Tighten loose V-belts when necessary. Complete operational check of controls and valves. Complete operational check of **ALL** safety devices (door switches, lint door switch, sail switch, burner and hi-limit thermostats).

## **C. LUBRICATION**

The motor bearings, idler bearings, and, under normal/most conditions, the basket (tumbler) bearings are permanently lubricated. It is physically possible to relubricate the basket (tumbler) bearings if you choose to do so even though this practice is not necessary. Use Shell Alvania #2 grease or its equivalent. The basket (tumbler) bearings used in the dryer **DO NOT** have a grease fitting. Provisions are made in the bearing housing for the addition of a grease fitting, which can be obtained elsewhere, or from **ADC** by ordering kit P/N 882159 (includes two [2] fittings).

# SECTION VII

## REVERSING TIMER SPIN/DWELL ADJUSTMENTS

Timer models have an electronic reversing timer in the electrical service box, which is located in the upper left rear area of the dryer.

Both the dwell (stop) time and the basket (tumbler) spin time are adjustable by mode selection switches located on the electronic timer (refer to the **illustration below**).

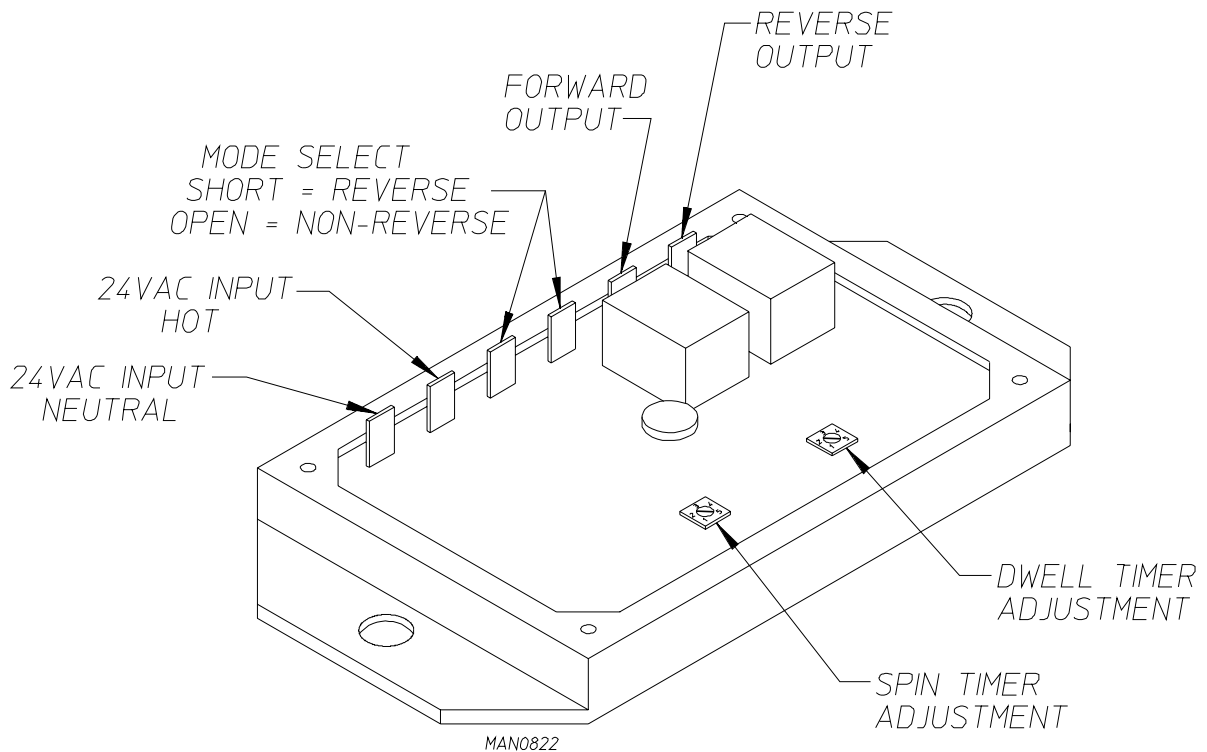

<b>TIMING LEGEND</b>					
<b>SPIN TIME</b>					
Adjustment Position Number	1	2	3	4	5
Time in Seconds*	30	60	90	120	150
<b>DWELL (STOP) TIME</b>					
Adjustment Position Number	1	2	3	4	5
Time in Seconds*	5	6.3	7.6	8.9	10.2
* Values shown are +/- 1-second.					





## **THE DATA LABEL**

### **1. MODEL NUMBER**

The model number is an **ADC** number, which describes the size of the dryer and the type of heat (gas, electric, or steam).

### **2. SERIAL NUMBER**

The serial number allows **ADC** to gather information on your particular dryer.

### **3. MANUFACTURING CODE NUMBER**

The manufacturing code number is a number issued by **ADC**, which describes **ALL** possible options on your particular model.

### **4. TYPE OF HEAT**

This describes the type of heat for your particular dryer: gas (either natural gas or liquid propane [L.P.]), electric, or steam.

### **5. HEAT INPUT (for GAS DRYERS)**

This describes the heat input in British Thermal Units per Hour (Btu/hr).

### **6. ORIFICE SIZE (for GAS DRYERS)**

Gives the number drill size used.

### **7. ELECTRIC SERVICE**

This describes the electric service for your particular model.

### **8. GAS MANIFOLD PRESSURE (for GAS DRYERS)**

This describes the manifold pressure taken at the gas valve tap.

# SECTION IX

## PROCEDURE FOR FUNCTIONAL CHECK OF REPLACEMENT COMPONENTS

### 1. Microprocessor Controller (Computer) Board

- a. Upon completing installation of the replacement microprocessor controller (computer) board, reestablish power to the dryer.
- b. Start the drying cycle by pressing any of the preset cycles in letters A-F.

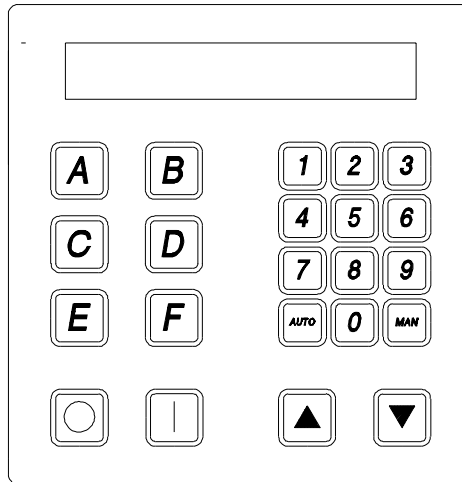

MC 8/02/01

MANS846

- c. Verify that the applicable indicator lights on the back side of the microprocessor controller (computer) board are lit. (Refer to the **illustration below.**)

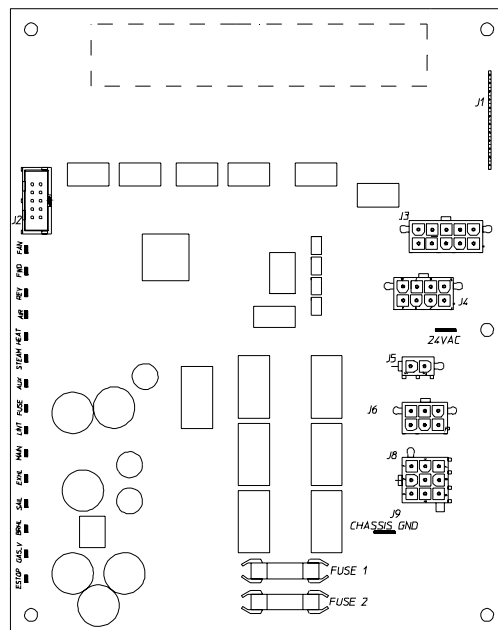

MANS825

2. For Models With Johnson Controls Direct Spark Ignition (DSI) Module (G760)

Theory Of Operation:

Start the drying cycle. When the gas burner ignites within the chosen trial for ignition time (6-seconds), the flame sensor detects gas burner flame and signals the DSI module to keep the gas valve open...as long as there is a call for heat. The DSI module will “LOCKOUT” if the gas burner flame is not sensed at the end of the trial for ignition period. The trial for ignition period will be repeated for a total of three (3) retries/trials (the initial try and two [2] more retries/trials). If the flame is not sensed at the end of the third retry/trial (inter-purge period of 30-seconds) the DSI module will “LOCKOUT” (light emitting diode [L.E.D.] flashes).

A steady L.E.D. indicator indicates normal operation.

No L.E.D. indicator indicates a power or an internal failure has occurred.

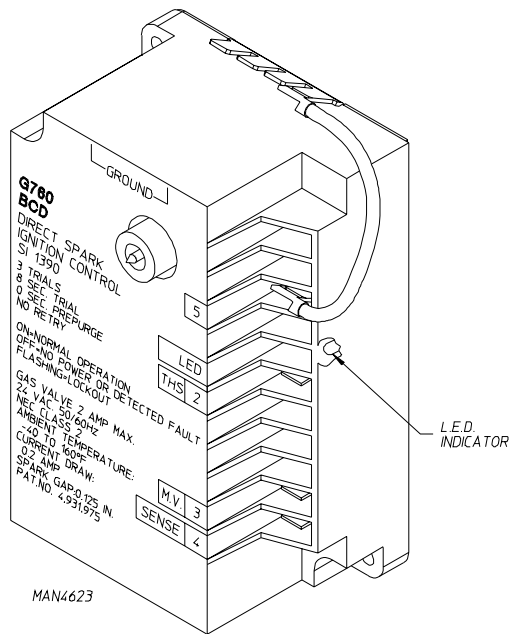

# SECTION X

## MANUAL RESET BURNER HI-LIMIT INSTRUCTIONS

### A. PHASE 7

This dryer was manufactured with a manual reset burner hi-limit thermostat, which is monitored by the Phase 7 computer. If the burner hi-limit is open prior to the start of the drying cycle, the dryer will start momentarily and then shut down, the Phase 7 computer will display “BURNER HIGH LIMIT FAULT” with an audio indication.

If the burner hi-limit opens during a drying cycle, the Phase 7 computer will also display the same error code described above, along with an audio indication. If the drum temperature is above 100° F (38° C), the dryer will continue to run with no heat for 3 minutes or until the drum temperature has dropped below 100° F (38° C). The clear/stop button on the Phase 7 keyboard (touch pad) **must be** pressed to clear the error condition. The open burner hi-limit **must be** reset “manually” prior to the start of the next cycle.

### B. DUAL TIMER

This dryer was manufactured with a manual reset burner hi-limit thermostat. If the burner hi-limit is open prior to the start of the drying cycle, or during the cycle, the dryer will not recognize the open state of the burner hi-limit and will start or continue through the drying cycle with no heat. Manual reset hi-limit **must be** reset manually.

This hi-temperature condition may be caused due to a restricted exhaust, poor airflow, or improper burner operation.

The location of the burner hi-limit is on the right side of the burner box, looking at the burner from the back of the dryer.

**WARNING:** Discontinue power to dryer before attempting to reset hi-limit.

#### IMPORTANT IMPORTANT IMPORTANTE

HEATING UNIT IS EQUIPPED WITH A HI-LIMIT THERMOSTAT WHICH *MUST BE RESET MANUALLY.*

WARNING - DISCONTINUE POWER TO DRYER BEFORE ATTEMPTING TO RESET HI-LIMIT.

L'ÉLÉMENT CHAUFFANT EST ÉQUIPÉ D'UN THERMOSTAT À LIMITE MAXIMALE QUI *DOIT ÊTRE RÉGLÉ MANUELLEMENT.*

MISE EN GARDE - COUPER LE COURANT D' ALIMENTATION DU SÈCHE-LINGE AVANT DE RÉGLER LA LIMITE MAXIMALE.

LA UNIDAD DE CALENTAMIENTO ESTÁ EQUIPADA CON UN THERMOSTATO DE LÍMITE SUPERIOR *QUE DEBE REINICIARSE MANUALMENTE.*

ADVERTENCIA - DESCONECTE LA ALIMENTACIÓN ELÉCTRICA A LA SECADORA ANTES DE REINICIAR EL LÍMITE SUPERIOR.

ADC P/N: 114076

# SECTION XI

## FIRE SUPPRESSION SYSTEM (F.S.S.)

# F.S.S. In Action

---



The exclusive Fire Suppression System (F.S.S.) will extinguish fires that may start in the drying basket (tumbler). A series of sensors positioned throughout the basket (tumbler) and interfaced with the microprocessor will trigger the F.S.S. water jet(s) to quickly extinguish the flames. The water jet(s) remain on for 2 minutes and will automatically activate again if a fire condition remains or reignites. While the water jet(s) are activated, the basket (tumbler) will jog to move the water throughout the load. The microprocessor will display that the system was activated and will continue to display until the dryer is attended to.

We have tried to make this manual as complete as possible and hope you will find it useful. **ADC** reserves the right to make changes from time to time, without notice or obligation, in prices, specifications, colors, and material, and to change or discontinue models.

## BEFORE YOU START!

### CHECK LOCAL CODES AND PERMITS

Call your local water company or the proper municipal authority for information regarding local codes.

**IMPORTANT:** It is your responsibility to have **ALL** plumbing connections made by a qualified professional to ensure that the plumbing installation is adequate and conforms to local, state, and federal regulations or codes.

**IMPORTANT:** It is the installation or owners responsibility to see that the necessary or required water, water pressure, pipe size, or connections are provided. Manufacturer assumes no responsibility if the F.S.S. **is not** connected, installed, or maintained properly.

## INSTALLATION

### 1. Requirements

The F.S.S. **must be** supplied with a minimum water pipe size of 1/2-inch and be provided with 40 psi +/- 20 psi (2.75 bar +/- 1.37 bar) of pressure. For use of optional manual bypass, a second source with the same piping and pressure requirements is required.

Flexible 1/2 feeds **must be** provided to avoid damage to electric water solenoid valve by vibration.

**IMPORTANT:** Flexible supply line/coupling **must be** used. Solenoid valve failure due to hard plumbing connections **WILL VOID WARRANTY**.

If the rear area of the dryer, or the water supply is located in an area where it will be exposed to cold/freezing temperatures, provisions **must be** made to protect these water lines from freezing.

**WARNING:** If the water in the supply line or water solenoid valve freezes, the F.S.S. **will be** INOPERATIVE!!

**IMPORTANT:** Appliance is to be connected to the water mains using a new hose-set and the old hose-sets **should not be** reused.

## 2. Water Connections:

The water connection is made to the 3/4"-11.5 NH hose adapter of the electric water solenoid valve, located at the rear upper midsection of the dryer (refer to the photo).

The water solenoid valve has a 3/8" M.P.T. connection supplied with a 3/4"-11.5 NH hose adapter to provide the minimum 1/2-inch supply (feed) line. Flexible supply line/coupling **must be** used in an effort to avoid damaging the electric water solenoid valve.



**NOTE:** The 3/4"-11.5 NH is a standard hose coupling screw thread. It **is not** to be confused with 3/4" N.P.T. The sealing of an NH connection is made with a washer opposed to the mating threads of an N.P.T. assembly. The two (2) thread designs **are not** compatible.

**IMPORTANT:** Flexible supply line/coupling **must be** used. Solenoid valve failure due to hard plumbing connections **WILL VOID WARRANTY**. **It is recommended** that a filter or strainer be installed in the water supply line.

### Typical water supply...

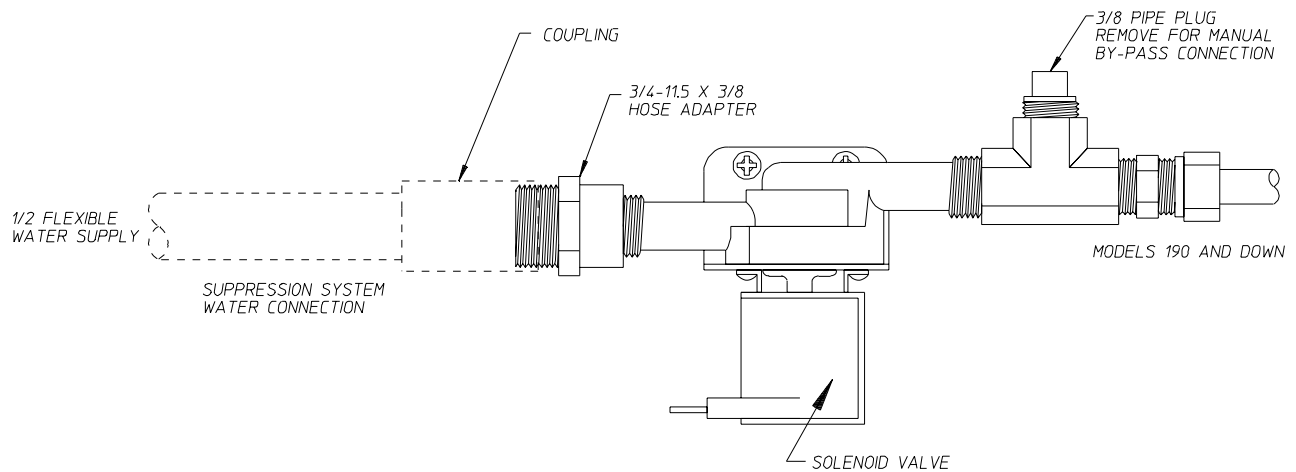

MGOLDSTEIN 7/1/03

MAN6771

## OPTIONAL MANUAL BYPASS

Provisions are made in the dryer's F.S.S. for the installation of an optional manual bypass. Depending on the model dryer, the connections for the manual bypass are made at the "T" or "four way" fitting located in the outlet supply side of the water solenoid valve. The use and connections of this manual bypass are at the option or discretion of the owner.

The water connection for the manual bypass is made to the "T" or "four way" fitting which has a 3/8" F.P.T. and a coupling **must be** used to provide the minimum 1/2" supply (feed) line.

If the rear area of the dryer, or the water supply is located in an area where it will be exposed to cold/freezing temperatures, provisions **must be** made to protect these water lines from freezing.

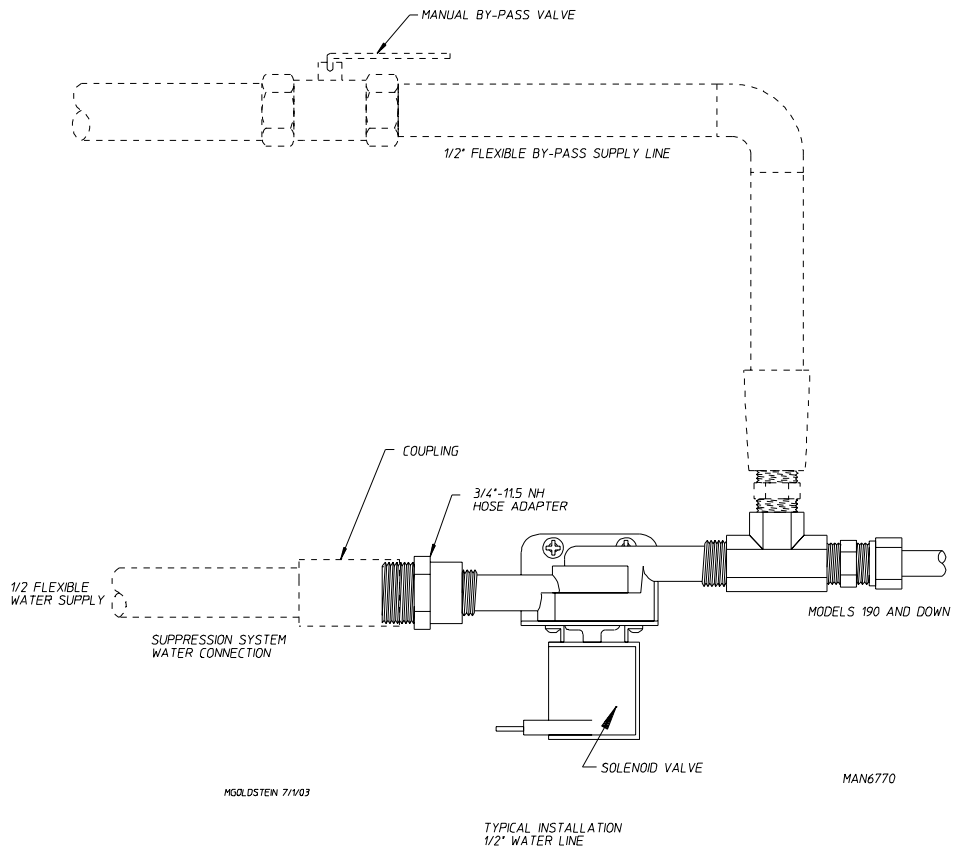

**WARNING:** If the water in the supply line or water solenoid valve freezes, the F.S.S. **will be** INOPERATIVE!!

The manual ball cock shutoff valve **must be** located outside of the dryer at a distance from the dryer where it is easily accessible.

### 3. Electrical Requirements

No independent external power source or supply connection is necessary. The 24 volt power to operate the F.S.S. is accomplished internally in the dryer (from the dryer controls).

**WARNING:** Electrical power **must be** provided to the dryer at **ALL** times. If the main electrical power supply to the dryer is disconnected, the F.S.S. is INOPERATIVE!!



# F.S.S. Theory of Operation

While the dryer is in an idle state or 20-seconds after the heat turns off, the Phase 7 control monitors the F.S.S. probe located in the top of the basket (tumbler) chamber and records the minimum temperature. If the minimum recorded F.S.S. probe temperature is no less than 120° F (48° C) and the control detects a 50° rise in temperature, this will be the trip point and the F.S.S. routine will activate.

While a drying cycle is in process and the heat has turned on at least once, the Phase 7 control monitors the exhaust temperature transducer. If the drying cycle temperature set point is set greater than 160° F (71° C) and the control detects an exhaust temperature rise 25° F greater than set point, this will be the trip point and the F.S.S. routine will activate. If set point is below 160° F (71° C) the trip point will be 185° F (85° C).

Once the F.S.S. routine is activated, water will be injected into the basket (tumbler) chamber. Anytime water is being injected into the basket (tumbler); the basket (tumbler) drive will turn the load for 1-second every 15-seconds. This process will continue for a minimum of 2 minutes. After 2 minutes has elapsed, the control will check if the temperature remained above trip point, if so water will remain on. The control will continue to check if temperature is above trip point every 30-seconds. If the water has been on for a constant 10 minutes, the water will be turned off regardless of the temperature. If the temperature has dropped below trip point, the control will turn off the water prior to 10 minutes.

## SYSTEM RESET

After the microprocessor determines that the situation is under control and shuts the water being injected into the basket (tumbler) off, the microprocessor display will read “Fire Suppression System activated,” and the horn/tone will sound until reset manually.

To reset the microprocessor once the control displays “Fire Suppression System activated,” press the red  key on the keyboard (touch pad).

## NON-COIN F.S.S. CHECK PROCEDURE

The operation of the water solenoid valve can be tested to ensure that the water supply system and valve are functional. Before attempting system check, be sure that **ALL** water supply shutoff valves to the dryer are in the OPEN position, and the dryer **must be** in the “READY” mode where no cycle is loaded or in progress.

The procedure is as follows:

1. Press and hold the RED STOP key (while in “READY” mode and no cycle in progress).
2. Press and hold the “A” key.
3. Water valve will open and water will be dispensed into basket (tumbler) area as long as both keys are held.

**IMPORTANT:** This is a test function only and the keys *should be* held and system activated for only a second or so, otherwise water will accumulate in various places in the dryer.

# F.S.S. Parts Break Down

Replacement parts can be obtained from your reseller or the **ADC** factory. When ordering replacement parts from the factory, FAX your order to **ADC** at (508) 678-9447 or telephone your order directly to the **ADC** Parts Department at (508) 678-9000. Please specify the dryer **model number** and **serial number** in addition to the **description** and **part number**, so that your order is processed accurately and promptly.

The illustrations on the following pages may not depict your particular dryer exactly. The illustrations are composite of the various dryer models. Be sure to check the descriptions of the parts thoroughly before ordering.

We have tried to make this manual as complete as possible and hope it will be useful. **ADC** reserves the right to make changes from time to time, without notice or obligation, in prices, specifications, colors, and material, and to change or discontinue models.

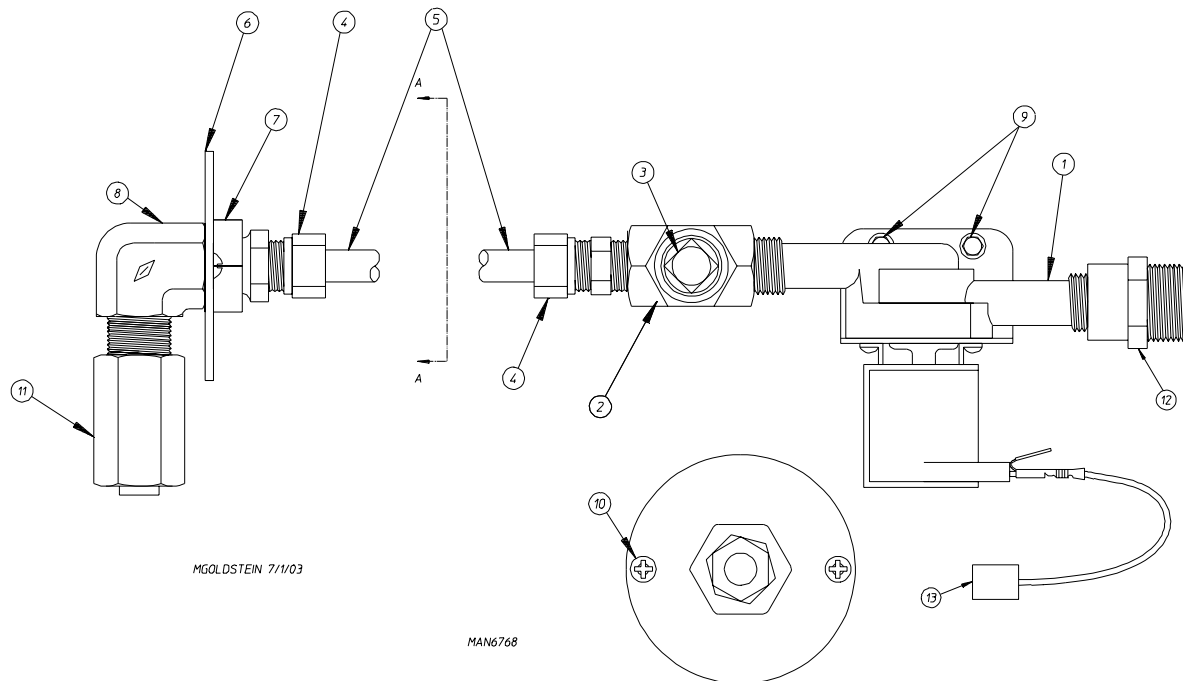

<u>Illus. No.</u>	<u>Part No.</u>	<u>Qty.</u>	<u>Description</u>
1	165114	1	F.S.S. System Solenoid Water Valve 24V 50/60 Hz
2	143220	1	3/8" F.P.T. Brass Tee
3	143251	1	3/8" M.P.T. Brass Plug
4	143208	2	3/8" Comp x 3/8" M.P.T. Brass Connector
5	143099*	6'	3/8" OD x 0.035 Wall Copper Tubing
6	311588	1	Sprinkler Head Mounting Plate
7	143303	1	3/8" N.P.T. Brass Locknut
8	143155	1	3/8" Brass Elbow 90°
9	150300	2	#10-16 x 1/2" Hex Washer TEK Screw
10	150301	2	#8-18 x 7/16" Phillips Pan Head TEK Screw
11	143581	1	3 GPM 3/8" F.P.T. Spray Nozzle
12	143025	1	3/4"-11.5 NH x 3/8" N.P.T. Hose Adapter
13	824081	1	R.C. Network Assembly

\* Sold by the foot.

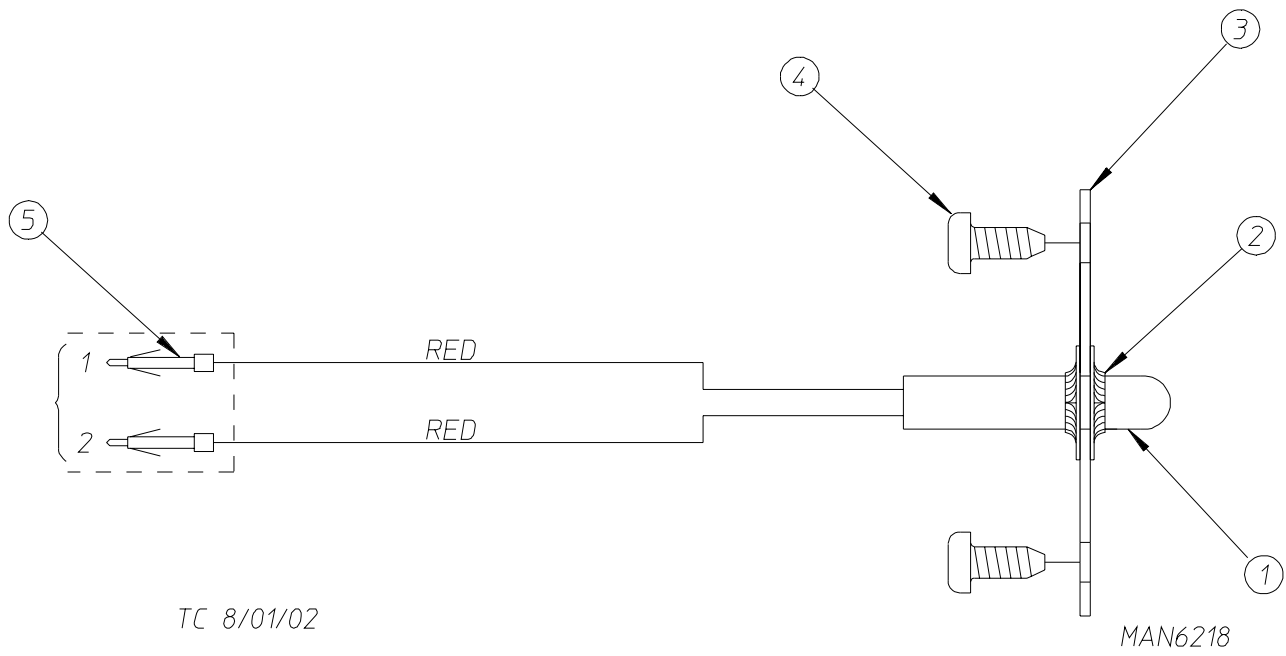

<u>Illus. No.</u>	<u>Part No.</u>	<u>Qty.</u>	<u>Description</u>
1	822752	1	F.S.S. Temperature Probe Assembly (includes illus. nos. 1 through 5)
2	154007	2	Push On Fastener
3	390390	1	Sensor Bracket ONLY
4	150301	2	#8-18 x 7/16" Phillips Pan Head TEK Screw
5	122647	1	Connector ONLY <b>(does not include terminals)</b>

