



# INSTALLATION INSTRUCTIONS

Accessory	Application	Publications No.
<b>CD CHANGER ATTACHMENT KIT</b>	<b>INSIGHT</b>	<b>All 23268</b>
		Issue Date <b>OCT 2001</b>

## PARTS LIST

### CD Changer Attachment Kit: P/N 08B26-S3Y-100

CD changer trim

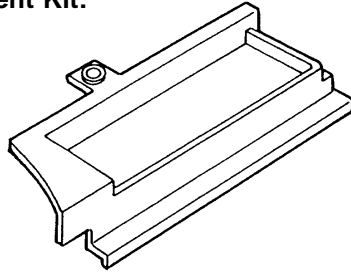

Front bracket

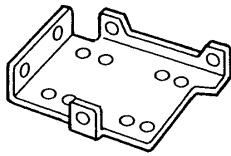

Rear bracket

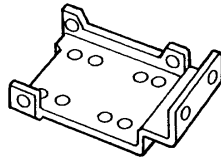

Front base bracket

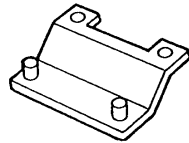

Rear base bracket

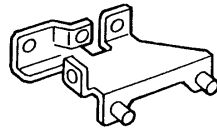

6 EPT sealers

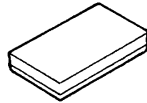

10 Cushion tapes

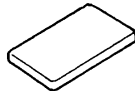

13 Short wire ties  
(1 not used)

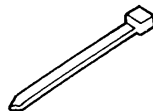

8 Washer-screws, 4 x 8 mm



4 Washer-bolts, 6 x 16 mm



4 Clip nuts



2 Clips



4 Self-tapping screws



4 Flange nuts



Bus cable

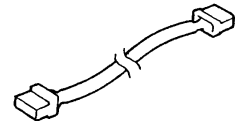

2 Spacers

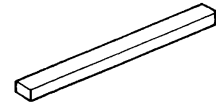

5 Long wire ties  
(4 not used)

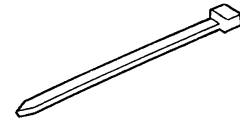

### CD Changer: P/N 08A26-1B1-100

CD changer

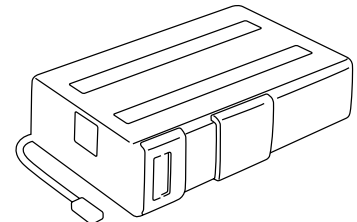

4 Washer-screws, 4 x 6 mm  
(Not used)



Adhesive seal sheet

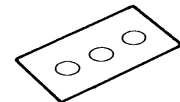

Locking covers

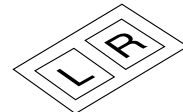

CD magazine

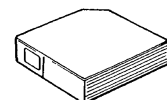

Owner's Manual

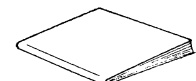

## TOOLS AND SUPPLIES REQUIRED

- #2 Phillips screwdriver
- Flat-tip screwdriver
- Stubby Phillips screwdriver
- 10 mm Combination wrench
- Ratchet
- 10 mm Socket
- Diagonal cutters
- Utility knife
- Tape measure
- Gloves

### Illustration of the CD Changer Installed on the Vehicle

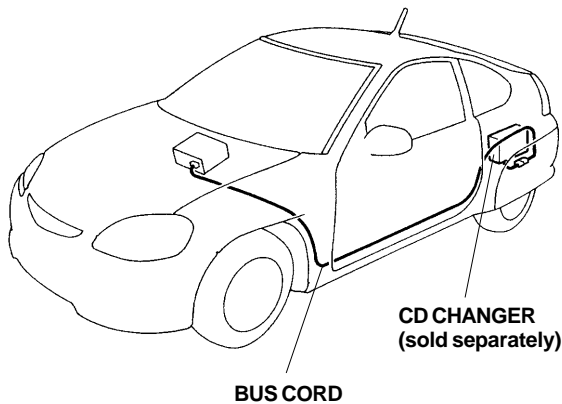

## INSTALLATION

**Customer Information:** The information in this installation instruction is intended for use only by skilled technicians who have the proper tools, equipment, and training to correctly and safely add equipment to your vehicle. These procedures should not be attempted by "do-it-yourselfers."

1. Write down the frequencies for the radio station preset buttons.
2. Disconnect the negative cable from the battery.

3. Remove the two bolts that fasten the glove box, and remove the glove box.

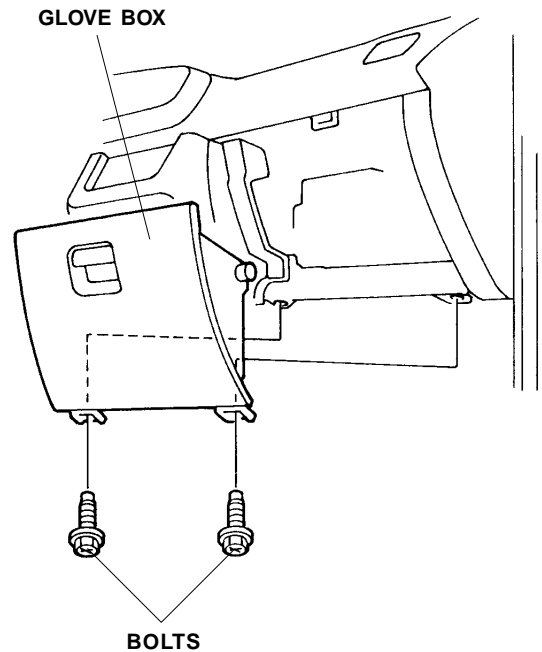

4. Remove the center lower cover by removing the two screws, releasing the 11 clips, and disconnecting the connector.

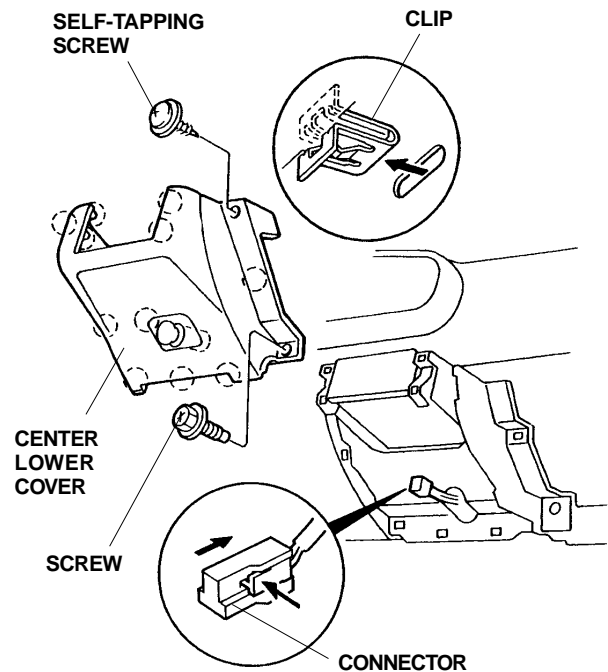

- Remove the self-tapping screws that fasten the radio, and pull the unit out toward you. Unplug the vehicle harness connector and the antenna lead from the rear of the radio.

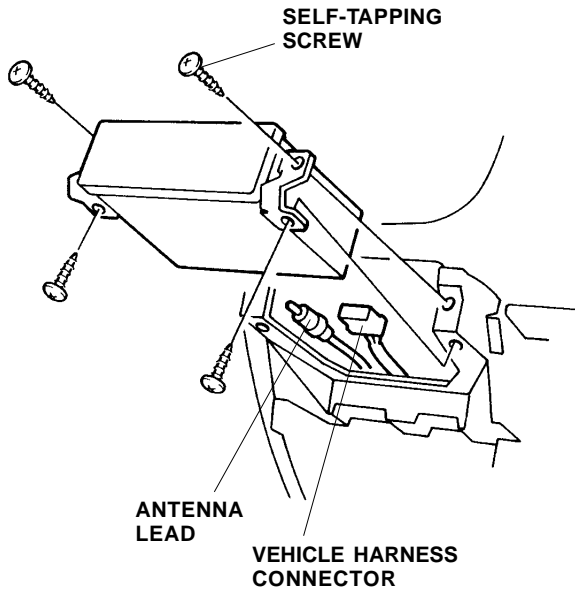

- Remove the driver's door sill trim (four retaining clips).

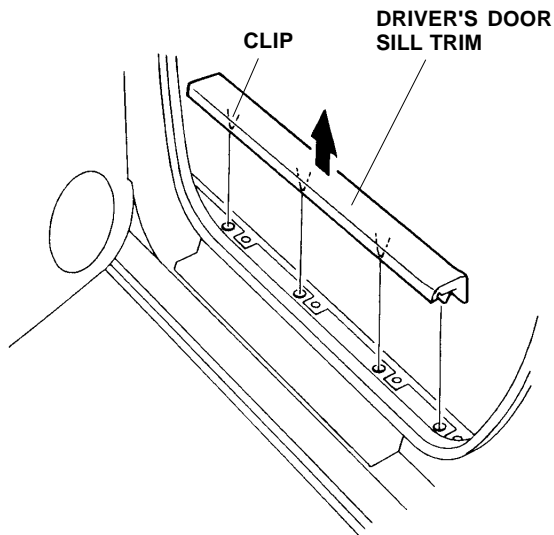

- Detach the clips, and pull the driver's side cowl carpet down and out of the way.

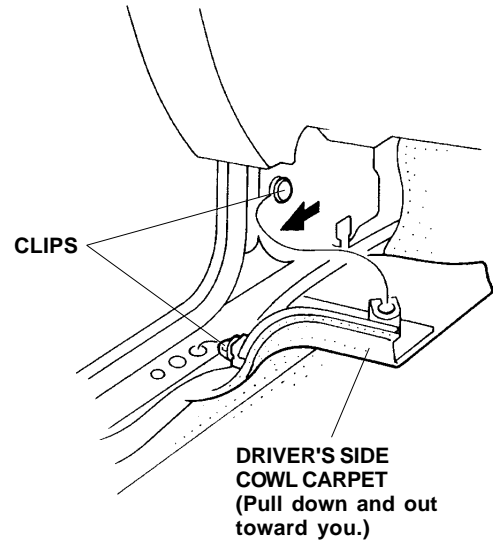

- Remove the B-pillar lower trim panel (four retaining clips). Take care not to damage the retaining clips.

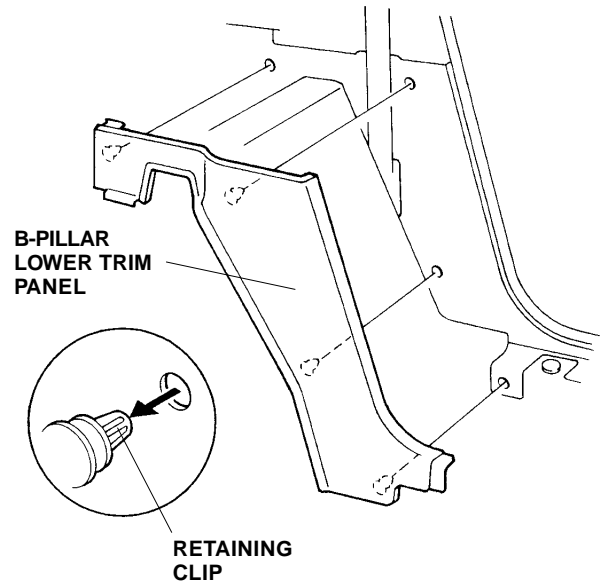

- Remove the four expansion clips that fasten the floor carpet, and fold the carpet down and out of the way.

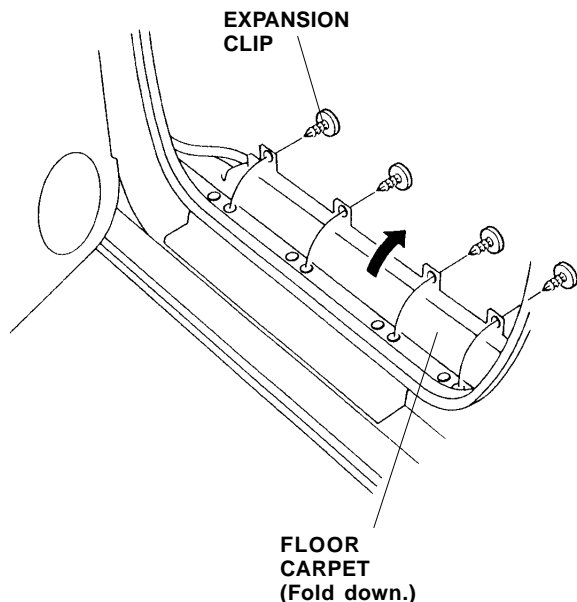

### Routing the BUS Cable

- Route one end of the BUS cable up under the dashboard, and out the radio opening. Position the BUS cable connector alongside the radio connector; then secure the BUS cable and the vehicle harness with two short wire ties in the areas shown.

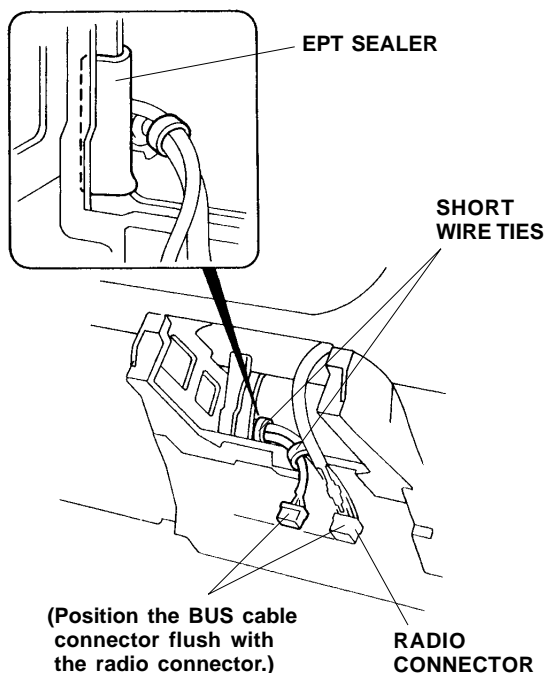

- Attach a piece of EPT sealer to the dash support to protect the BUS cable.

- Route the BUS cable above the steering shaft, and secure it to the vehicle harness with four short wire ties in the areas shown.

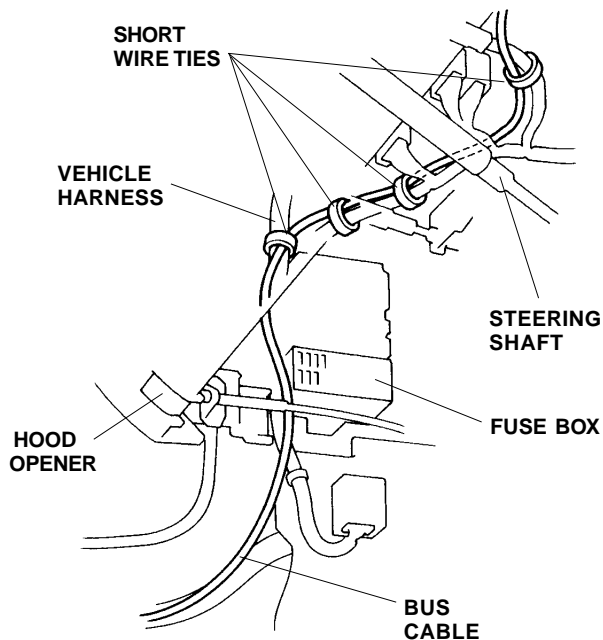

- Route the BUS cable down alongside the fuse box, and secure it to the body panel with one cushion tape. Secure the BUS cable to the vehicle harness with the two short wire ties.

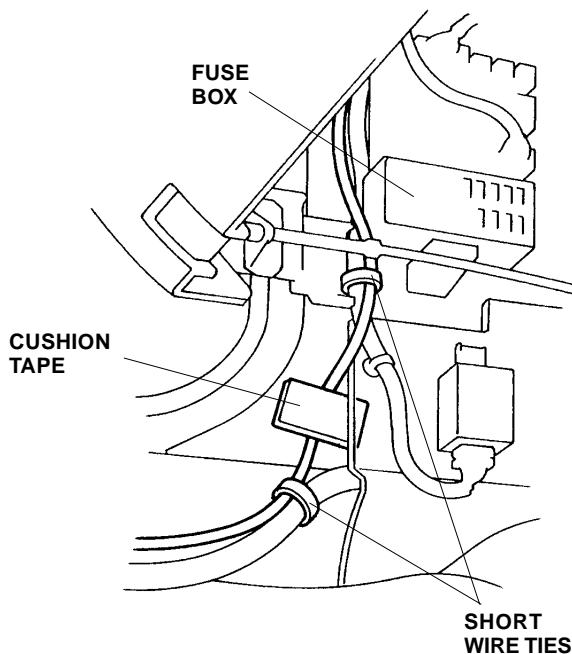

- Continue routing the BUS cable toward the rear of the vehicle. Measure 35 mm below the door opening, and secure the BUS cable to the body with four cushion tapes.

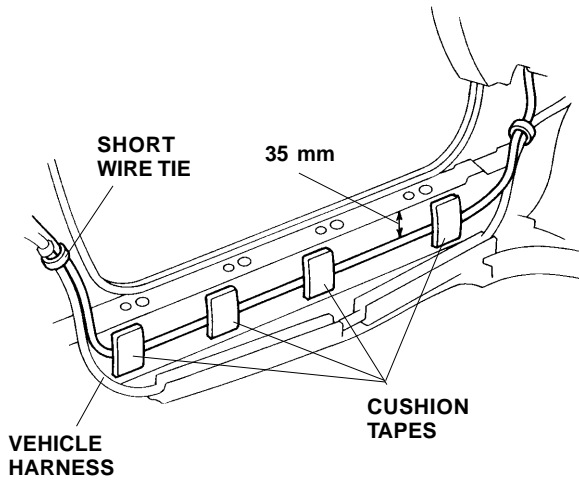

- Secure the BUS cable to the vehicle harness with one short wire tie in the area shown.
- Open the tailgate, and remove the cargo floor mat.

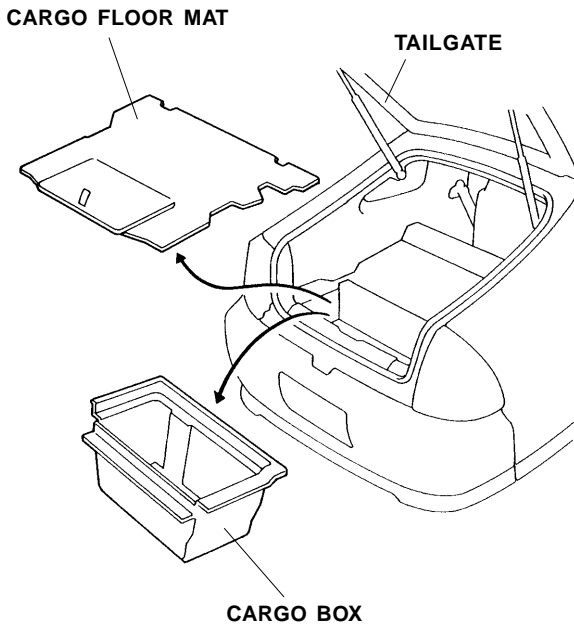

- Remove the cargo box.

- Remove the rear side trim panel (three expansion clips).

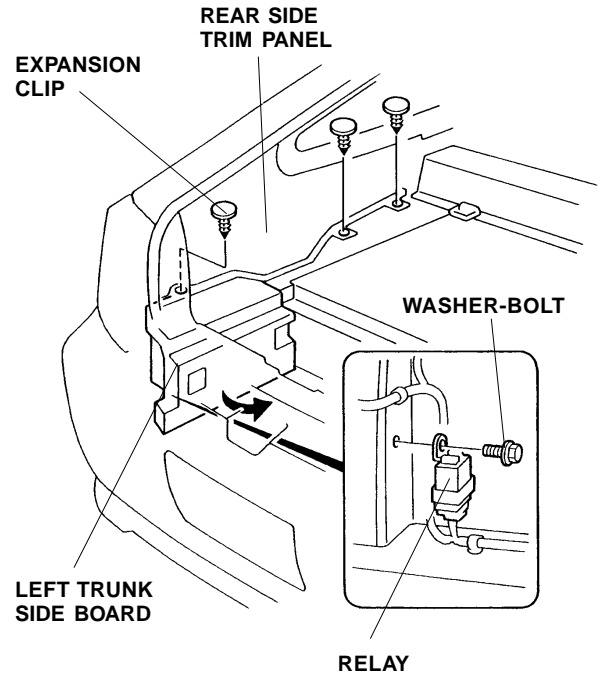

- Remove the left trunk side board by pulling out on the back and toward you.
- Locate the relay mounted to the lower trunk panel. Remove the washer-bolt to free the relay.
- Remove the middle bulkhead cover (pry out the seven screw covers, and remove the seven screws).

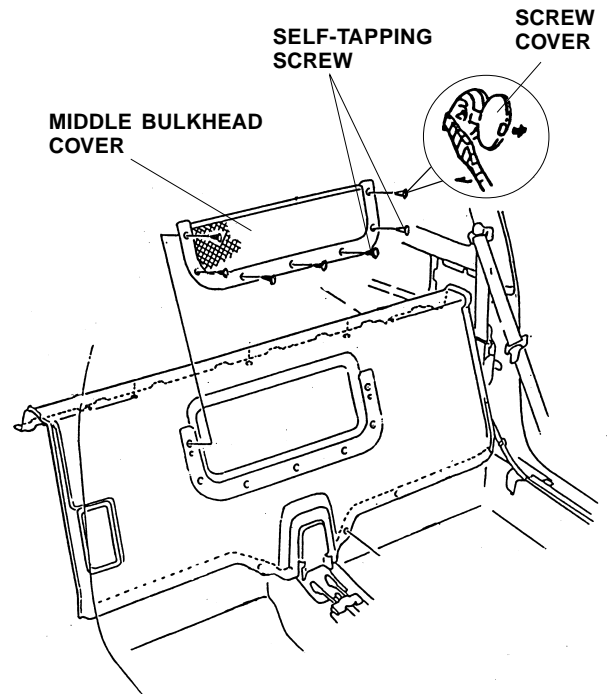

22. Remove the three clips, and fold down the top portion of the middle carpet. If the vehicle you are working on is equipped with rear speakers, remove the speakers and rear speaker holders.

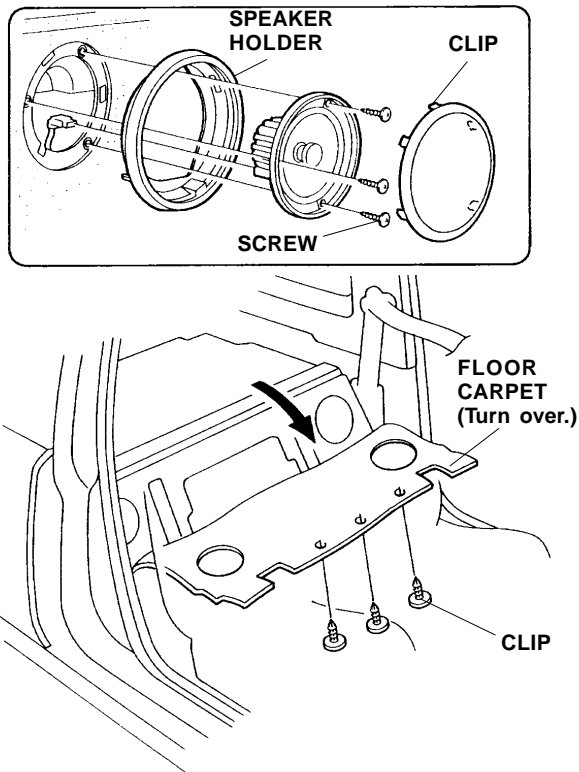

23. Continue routing the BUS cable toward the rear of the vehicle alongside the vehicle harness, then up and out through the cutout in the area shown. While wearing gloves to protect your hands, reach through the speaker hole, and secure the BUS cable to the vehicle harness with four short wire ties in the areas shown.

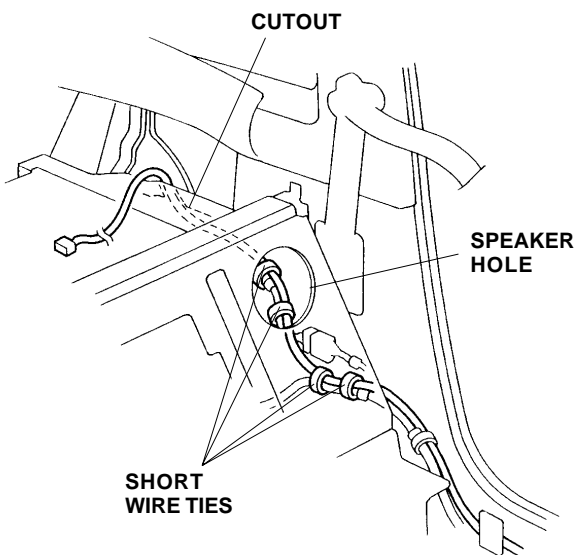

24. Attach one cushion tape around the lower edge of the hole in the inner panel; then route the BUS cable toward the rear over the cushion tape. Secure the BUS cable to the inner panel with additional cushion tape.

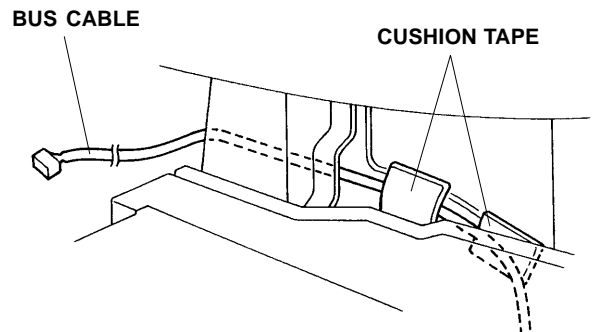

25. Route the BUS cable down, and secure it to the trunk panel with two cushion tapes.

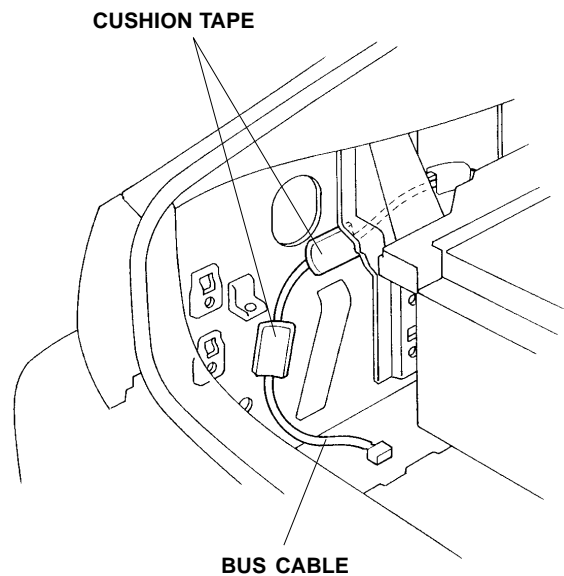

## Installing the CD Changer

26. Carefully unpack the CD changer. Remove the three shipping clips, and discard the shipping cover. Save the shipping clips for your customer in the event the unit needs to be serviced.

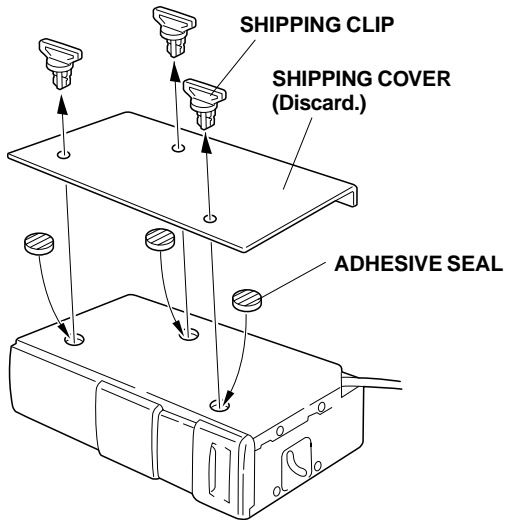

27. Install an adhesive seal (included with the CD changer kit) over each of the three clip holes.

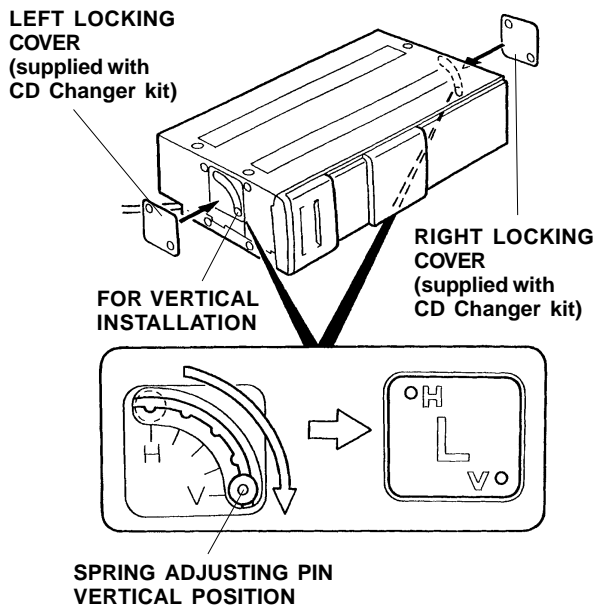

28. Visually check the location of the spring adjusting pins on both sides of the CD changer. If the spring adjusting pins are not in the vertical (V) position, move the pins to the vertical (V) position with a small flat-tip screwdriver.
29. Remove the backing from the two adhesive covers, and attach one cover to each side of the CD changer. Align the two diagonally opposite holes with the H and V positions.

30. Position the front and rear brackets on the CD changer, and install four 4 x 8 mm washer-screws into each bracket.

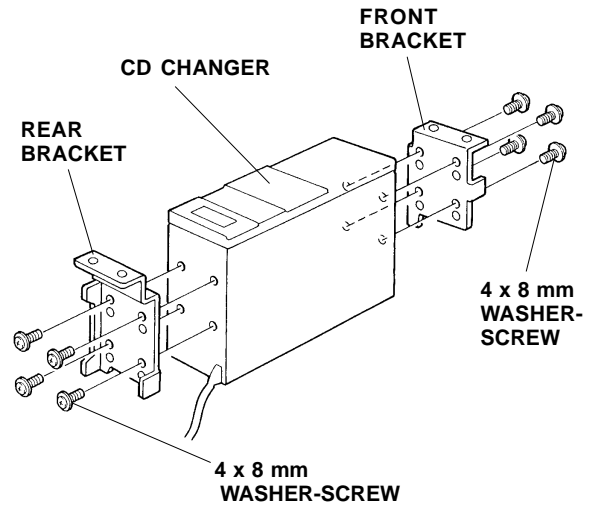

31. Using a utility knife, cut out the inside line of the center area on the CD changer trim.

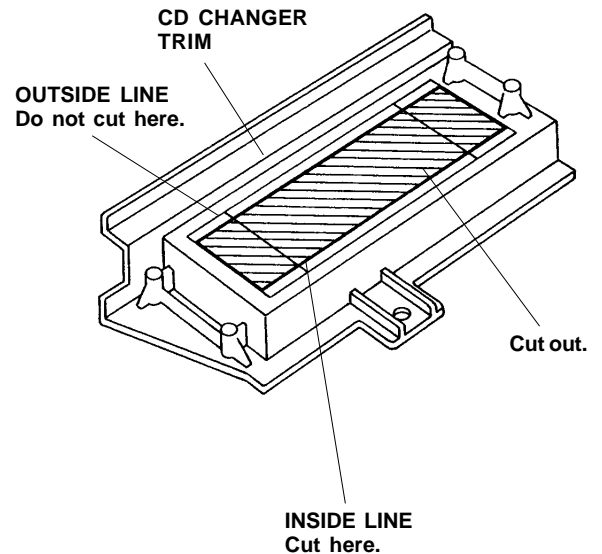

32. Place the CD changer trim on the CD changer, and install the four self-tapping screws.

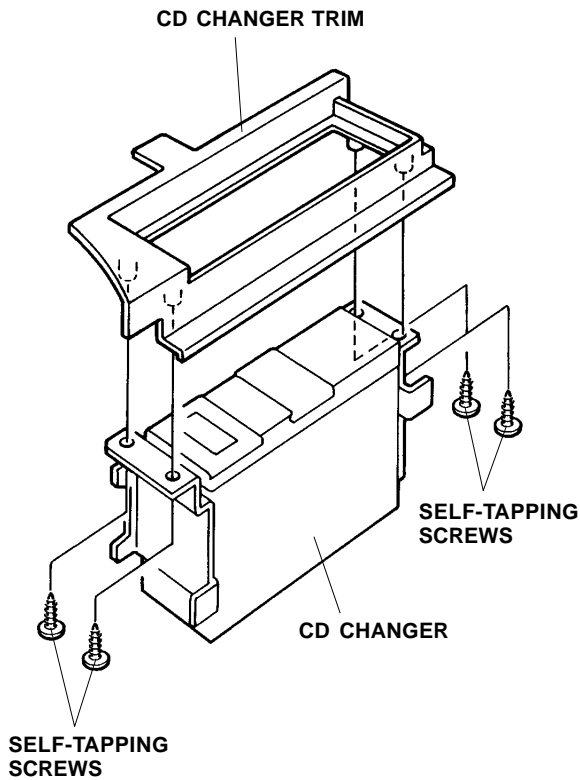

33. Remove 40 to 50 mm of the adhesive backing from the back of each spacer, and fold them back. Position the spacers on the CD changer against the CD changer trim; then carefully remove the adhesive backings while holding the spacers in place. Be careful not to tear the adhesive backings.

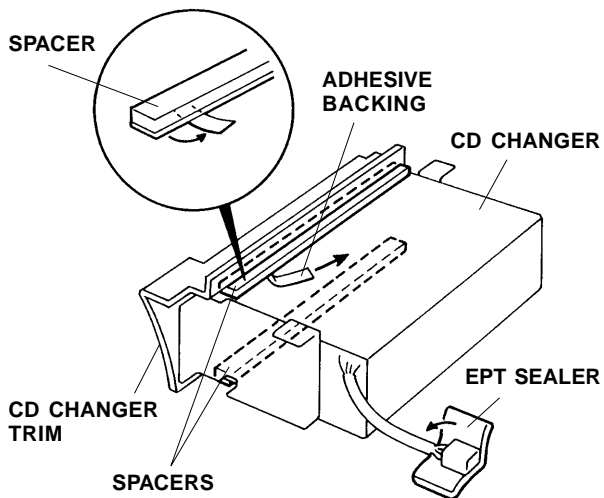

34. Wrap one EPT sealer around the connector from the CD changer.

35. Remove the vehicle harness clip from the hole in the inner panel.

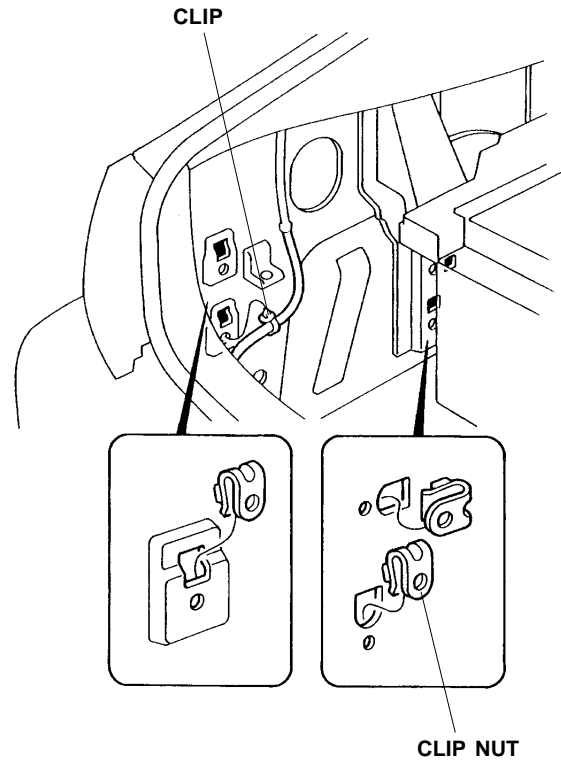

36. Slide one clip nut onto each of the four holes in the inner panel.

37. Apply one EPT sealer to the left taillight harness.

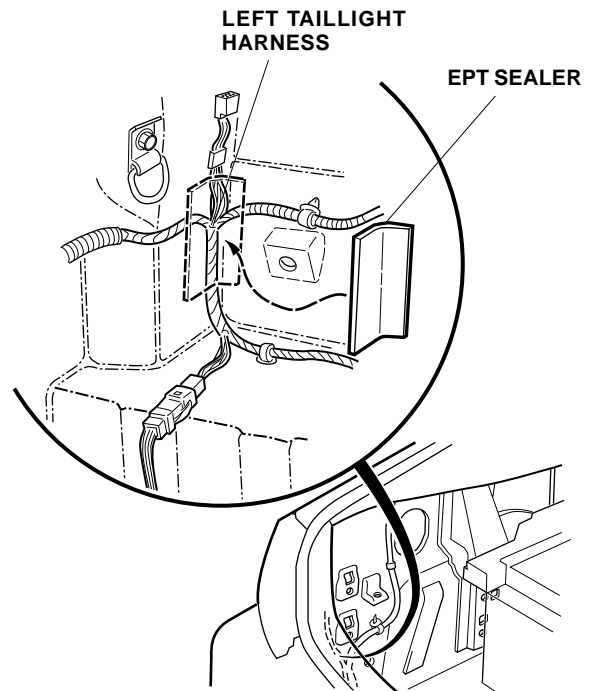

38. Cut one piece of EPT sealer in half. Attach the halves to the rear clip nuts you installed in step 36.

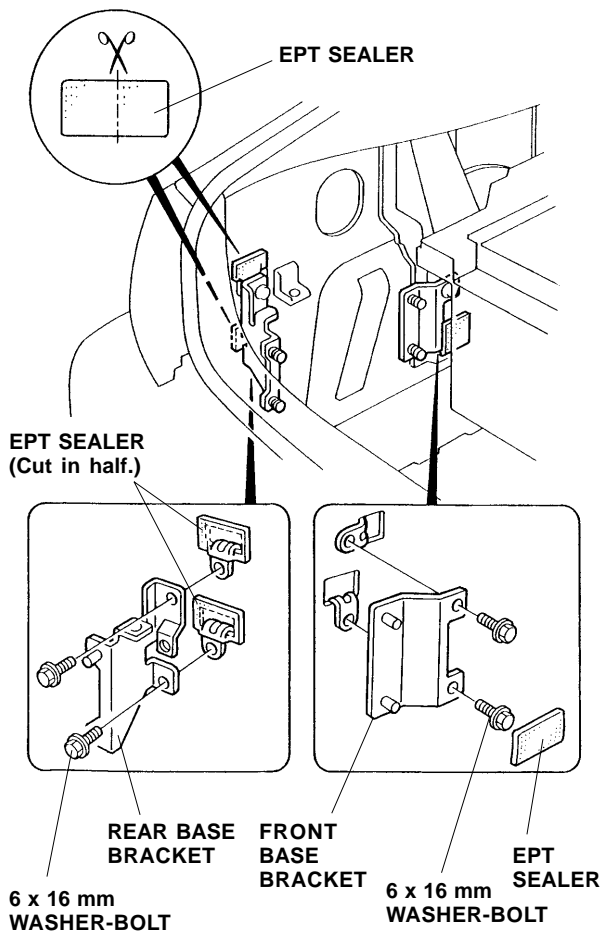

39. Position the rear base bracket on the clip nuts, and install two 6 x 16 mm washer-bolts. Tighten the bolts securely.
40. Position the front base bracket on the clip nuts and install two 6 x 16 mm washer-bolts. Tighten the bolts securely. Attach one EPT sealer over the head of the lower bracket bolt.
41. Push the clip of the vehicle wire harness removed in step 35 into the hole in the rear base bracket.

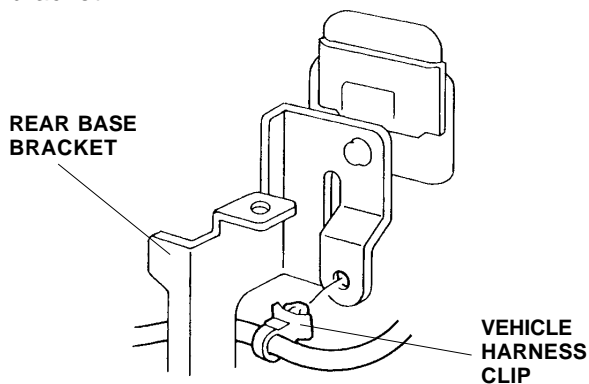

42. Position the CD changer on the studs extending from the front and rear base brackets, and install the four flange nuts. Install the CD changer first on the front bracket, then the rear bracket.

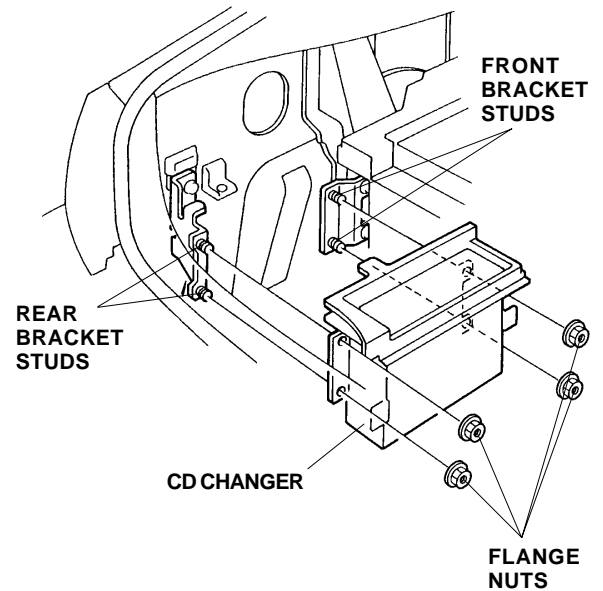

43. Reinstall the relay that was removed in step 20.
44. Plug the BUS cable connector into the CD changer.

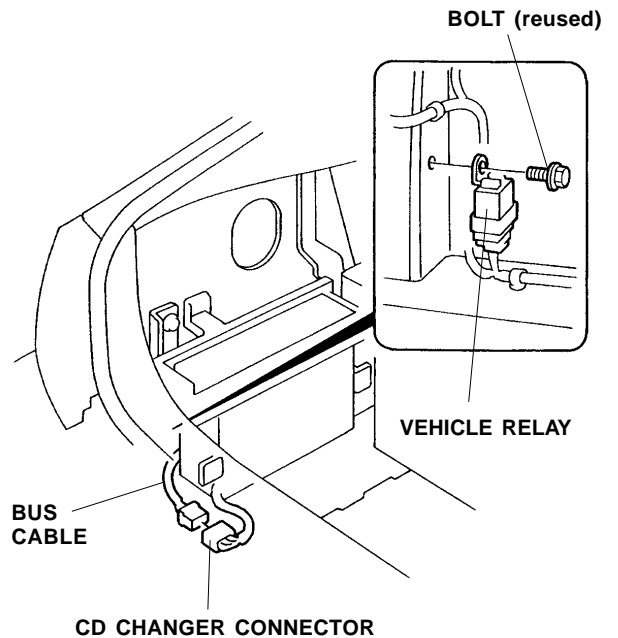

45. Secure the BUS cable connector to the vehicle harness 135 mm away from the vehicle harness clip with one long wire tie. Attach the BUS cable to the corner of the body panel with one cushion tape in the area shown.

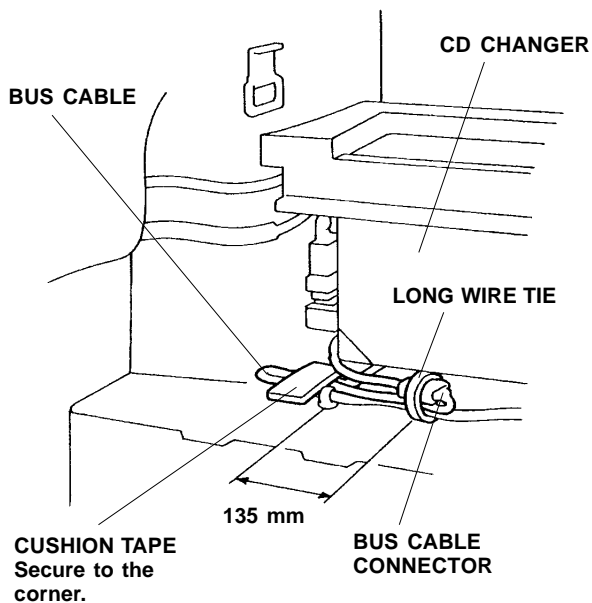

46. Using a utility knife, cut out the marked areas from the back of the left trunk side board. First cut out areas A, B, and C, then area D.

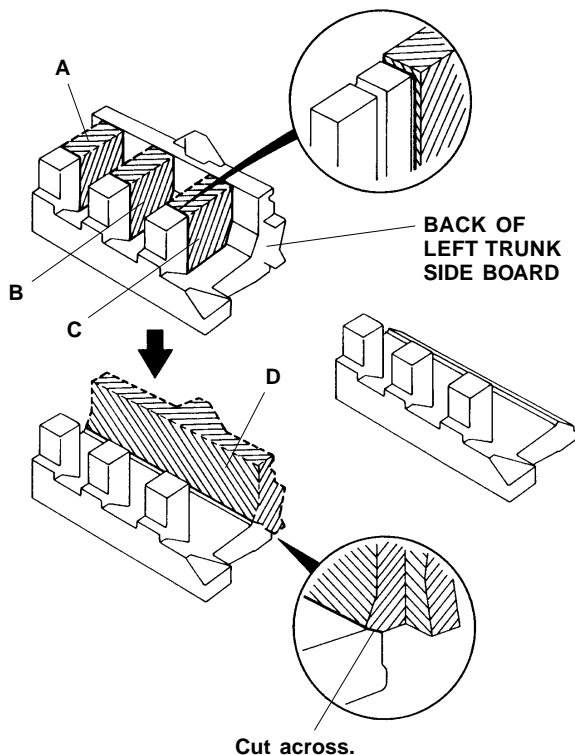

47. Reinstall the left trunk side board on the CD changer brackets, and install the two clips.

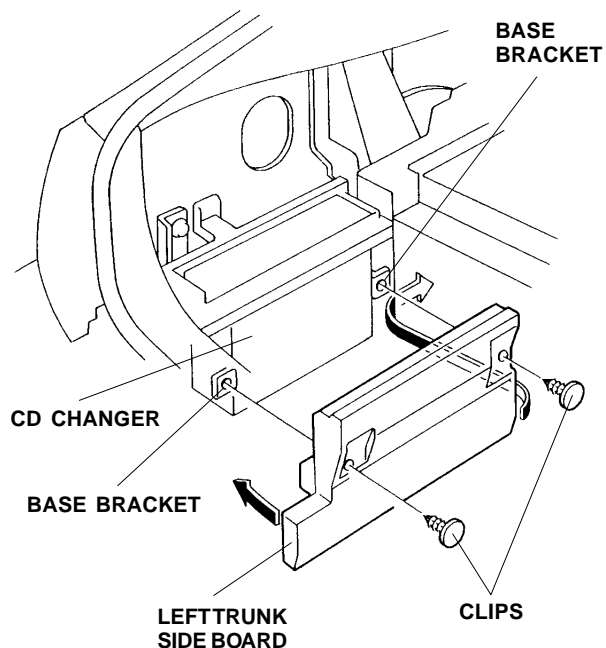

48. Reinstall the trunk box, and check that the CD can be loaded and ejected properly by opening the lid of the CD changer.
49. Plug the BUS cable connector, the radio connector, and the antenna lead into the rear of the radio.

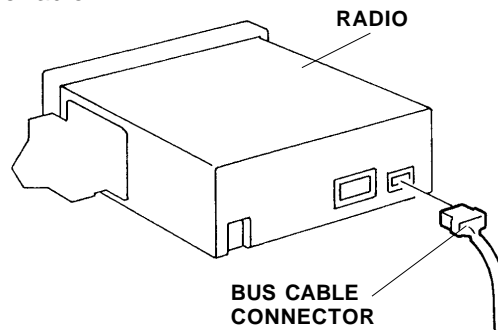

50. Check that all wire harnesses are routed properly and all connectors are plugged in.
51. Reconnect the negative cable to the battery.
52. Reset the clock and the radio station presets.
53. Reinstall all removed parts.
54. Check the operation of the CD changer as described in the Owner's Manual supplied.
55. Put the CD Changer Owner's Manual and the shipping screws (removed in step 26) in the glove box for your customer.