

ML-200 Non-Tilting

Phase 5

Installation/Operator's Manual

WARNING: For your safety the information in this manual must be followed to minimize the risk of fire or explosion or to prevent property damage, personal injury or death.

— Do not store or use gasoline or other flammable vapor and liquids in the vicinity of this or any other appliance.

— **WHAT DO YOU DO IF YOU SMELL GAS**

- * Do not try to light any appliance.
- * Do not touch any electrical switch; do not use any phone in your building.
- * Clear the room, building or area of all occupants.
- * Immediately call your gas supplier from a neighbor's phone. Follow the gas supplier's instructions.
- * If you cannot reach your gas supplier, call the fire department.

— Installation and service must be performed by a qualified installer, service agency or the gas supplier.

AVERTISSEMENT: Assurez-vous de bien suivre les instructions données dans cette notice pour réduire au minimum le risque d'incendie ou d'explosion ou pour éviter tout dommage matériel, toute blessure ou la mort.

— Ne pas entreposer ni utiliser d'essence ni d'autres vapeurs ou liquides inflammables dans le voisinage de cet appareil ou de tout autre appareil.

— **QUE FAIRE SI VOUS SENTEZ UNE ODEUR DE GAZ:**

- * Ne pas tenter d'allumer d'appareil.
- * Ne touchez à aucun interrupteur. Ne pas vous servir des téléphones se trouvant dans le bâtiment où vous vous trouvez..
- * Évacuez la pièce, le bâtiment ou la zone.
- * Appelez immédiatement votre fournisseur de gaz depuis un voisin. Suivez les instructions du fournisseur.
- * Si vous ne pouvez rejoindre le fournisseur de gaz, appelez le service des incendies.

— L'installation et l'entretien doivent être assurés par un installateur ou un service d'entretien qualifié ou par le fournisseur de gaz.



For replacement parts, contact the distributor from which the dryer was purchased or

American Dryer Corporation

88 Carrant Road

Fall River MA 02720-4781

Telephone: (508) 678-9000 / Fax: (508) 678-9447

e-mail: techsupport@amdry.com

Retain This Manual In A Safe Place For Future Reference

American Dryer Corporation products embody advanced concepts in engineering, design, and safety. If this product is properly maintained, it will provide many years of safe, efficient, and trouble-free operation.

ONLY qualified technicians should service this equipment.

OBSERVE ALL SAFETY PRECAUTIONS displayed on the equipment or specified in the installation/operator's manual included with the dryer.

The following “**FOR YOUR SAFETY**” caution **must be** posted near the dryer in a prominent location.

FOR YOUR SAFETY

Do not store or use gasoline or other flammable vapors or liquids in the vicinity of this or any other appliance.

POUR VOTRE SÉCURITÉ

Ne pas entreposer ni utiliser d'essence ni d'autres vapeurs ou liquides inflammables dans le voisinage de cet appareil ou de tout autre appareil.

We have tried to make this manual as complete as possible and hope you will find it useful. **ADC** reserves the right to make changes from time to time, without notice or obligation, in prices, specifications, colors, and material, and to change or discontinue models.

Important

For your convenience, log the following information:

DATE OF PURCHASE _____ MODEL NO. **ML-200 Non-Tilting**

DISTRIBUTORS NAME _____

Serial Number(s) _____

Replacement parts can be obtained from your distributor or the **ADC** factory. When ordering replacement parts from the factory, you can FAX your order to **ADC** at (508) 678-9447 or telephone your orders directly to the **ADC** Parts Department at (508) 678-9000. Please specify the dryer **model number** and **serial number** in addition to the **description** and **part number**, so that your order is processed accurately and promptly.

“IMPORTANT NOTE TO PURCHASER”

Information must be obtained from your local gas supplier on the instructions to be followed if the user smells gas. These instructions must be posted in a prominent location near the dryer.

IMPORTANT

YOU MUST DISCONNECT and LOCKOUT THE ELECTRIC SUPPLY and THE GAS SUPPLY or THE STEAM SUPPLY BEFORE ANY COVERS or GUARDS ARE REMOVED FROM THE MACHINE TO ALLOW ACCESS FOR CLEANING, ADJUSTING, INSTALLATION, or TESTING OF ANY EQUIPMENT per OSHA (Occupational Safety and Health Administration) STANDARDS.

“Caution: Label all wires prior to disconnection when servicing controls. Wiring errors can cause improper operation.”

«Attention: Lor des opérations d’entretien des commandes étiqueter tous fils avant de les déconnecter. Toute erreur de câblage peut être une source de danger et de panne.»

CAUTION

DRYERS SHOULD NEVER BE LEFT UNATTENDED WHILE IN OPERATION.

WARNING

CHILDREN SHOULD NOT BE ALLOWED TO PLAY ON OR NEAR THE DRYERS.
CHILDREN SHOULD BE SUPERVISED IF NEAR DRYERS IN OPERATION.

FOR YOUR SAFETY

DO NOT DRY MOP HEADS IN THE DRYER.

DO NOT USE DRYER IN THE PRESENCE OF DRY CLEANING FUMES.

WARNING

UNDER NO CIRCUMSTANCES should the door switch or the heat circuit devices ever be disabled.

WARNING

The dryer must never be operated with any of the back guards, outer tops, or service panels removed. **PERSONAL INJURY or FIRE COULD RESULT.**

WARNING

DRYER MUST NEVER BE OPERATED WITHOUT THE LINT FILTER (SCREEN) IN PLACE, EVEN IF AN EXTERNAL LINT COLLECTION SYSTEM IS USED.

IMPORTANT

PLEASE OBSERVE ALL SAFETY PRECAUTIONS displayed on the equipment or specified in the installation/operator's manual included with the dryer.

Dryers **must not** be installed or stored in an area where it will be exposed to water or weather.

The wiring diagram for the dryer is located in the front electrical control box area.

Table of Contents

SECTION I

IMPORTANT INFORMATION	3
A. RECEIVING and HANDLING	3
B. SAFETY PRECAUTIONS	4

SECTION II

SPECIFICATIONS/DIMENSIONS and COMPONENT IDENTIFICATION	6
A. SPECIFICATIONS (GAS and STEAM Models)	6
B. ML-200 DIMENSIONS and COMPONENT LOCATION	7

SECTION III

INSTALLATION PROCEDURES	9
A. REASSEMBLY OF DRYER	9
B. LOCATION REQUIREMENTS	12
C. FRESH AIR SUPPLY	13
D. EXHAUST REQUIREMENTS	14
E. COMPRESSED AIR SUPPLY SYSTEM	16
F. ELECTRICAL INFORMATION	17
G. GAS INFORMATION	21
H. STEAM INFORMATION	25
I. PREPARATION FOR OPERATION/START-UP	29
J. PREOPERATIONAL TESTS	30
K. SHUT DOWN INSTRUCTIONS	32

SECTION IV

SERVICE/PARTS INFORMATION	33
A. SERVICE	33
B. PARTS	33

SECTION V

WARRANTY INFORMATION	34
A. RETURNING WARRANTY CARD(S)	34
B. WARRANTY	34
C. RETURNING WARRANTY PART(S)	34

SECTION VI
ROUTINE MAINTENANCE 36
A. CLEANING 36
B. ADJUSTMENTS 38
C. LUBRICATION 38

SECTION VII
COMPONENT SYSTEM DESCRIPTIONS 39
A. TUMBLER (BASKET) DRIVE SYSTEM 39
B. TUMBLER/BASKET 39
C. AIR BLOWER DRIVE SYSTEM 39
D. SAFETY DEVICES 40
E. STEAM DAMPER ACTUATOR SYSTEM 41

SECTION VIII
TROUBLESHOOTING 42

SECTION IX
PROCEDURE FOR FUNCTIONAL CHECK OF REPLACEMENT
COMPONENTS 51

SECTION X
MANUAL RESET HI-LIMIT INSTRUCTIONS 54

SECTION I

IMPORTANT INFORMATION

A. RECEIVING and HANDLING

The dryer is shipped in a protective stretch wrap cover with protective cardboard corners and top cover (or optional box) as a means of preventing damage in transit. Upon delivery, the dryer and/or packaging, and wooden skid **should be** visually inspected for shipping damage. If any damage whatsoever is noticed, inspect further before delivering carrier leaves.

Dryers damaged in shipment:

1. **ALL** dryers **should be** inspected upon receipt and before they are signed for.
2. If there is suspected damage or actual damage, the trucker's receipt **should be** so noted.
3. If the dryer is damaged beyond repair, it **should be** refused. Those dryers which were not damaged in a damaged shipment **should be** accepted, but the number received and the number refused **must be** noted on the receipt.
4. If you determine that the dryer was damaged after the trucker has left your location, you should call the delivering carrier's freight terminal immediately and file a claim. The freight company considers this concealed damage. This type of freight claim is very difficult to get paid and becomes extremely difficult when more than a day or two passes after the freight was delivered. It is your responsibility to file freight claims. Dryer/parts damaged in transit **cannot** be claimed under warranty.
5. Freight claims are the responsibility of the consignee, and **ALL** claims **must be** filed at the receiving end. **ADC** assumes no responsibility for freight claims or damages.
6. If you need assistance in handling the situation, please contact the **ADC** Traffic Manager at (508) 678-9000.

IMPORTANT: The tumbler section of the dryer **must be** transported and handled in an upright position at **ALL** times.

B. SAFETY PRECAUTIONS

WARNING: For your safety, the information in this manual *must be* followed to minimize the risk of fire or explosion or to prevent property damage, personal injury, or loss of life.

WARNING: The dryer *must never be* operated with any of the back guards, outer tops, or service panels removed. PERSONAL INJURY or FIRE COULD RESULT.

1. **DO NOT** store or use gasoline or other flammable vapors and liquids in the vicinity of this or any other appliance.
2. Purchaser/user should consult the local gas supplier for proper instructions to be followed in the event the user smells gas. The instructions **should be** posted in a prominent location.
3. WHAT TO DO IF YOU SMELL GAS...
 - a. **DO NOT** try to light any appliance.
 - b. **DO NOT** touch any electrical switch.
 - c. **DO NOT** use any phone in your building.
 - d. Clear the room, building, or area of **ALL** occupants.
 - e. Immediately call your gas supplier from a neighbor's phone. Follow the gas supplier's instructions.
 - f. If you **cannot** reach your gas supplier, call the fire department.
4. Installation and service **must be** performed by a qualified installer, service agency, or gas supplier.
5. Dryer(s) **must be** exhausted to the outdoors.
6. Although **ADC** produces a very versatile machine, there are some articles that, due to fabric composition or cleaning method, **should not be** dried in it.

WARNING: Dry only water-washed fabrics. **DO NOT** dry articles spotted or washed in dry cleaning solvents, a combustible detergent, or "all purpose" cleaner.
EXPLOSION COULD RESULT.

WARNING: DO NOT dry rags or articles coated or contaminated with gasoline, kerosene, oil, paint, or wax.
EXPLOSION COULD RESULT.

WARNING: DO NOT dry mop heads. Contamination by wax or flammable solvents will create a fire hazard.

WARNING: *DO NOT* use heat for drying articles that contain plastic, foam, sponge rubber, or similarly textured rubber materials. Drying in a heated tumbler (basket) may damage plastics or rubber and also may be a fire hazard.

7. A program **should be** established for the inspection and cleaning of lint in the heating unit area, exhaust duct work, and inside the dryer. The frequency of inspection and cleaning can best be determined from experience at each location.

WARNING: The collection of lint in the burner area and exhaust duct work can create a potential fire hazard.

8. For personal safety, the dryer **must be** electrically grounded in accordance with local codes and/or the National Electrical Code ANSI/NFPA NO. 70-LATEST EDITION, or in Canada, the Canadian Electrical Codes Parts 1 & 2 CSA C22.1-1990 or LATEST EDITION.

NOTE: Failure to do so will VOID THE WARRANTY.

9. **UNDER NO CIRCUMSTANCES** should the dryer door switches, lint drawer switch, heat safety circuit ever be disabled.

WARNING: PERSONAL INJURY or FIRE COULD RESULT.

10. This dryer is not to be used in the presence of dry cleaning solvents or fumes.
11. Remove articles from the dryer as soon as the drying cycle has been completed.

WARNING: Articles left in the dryer after the drying and cooling cycles have been completed can create a fire hazard.

12. **DO NOT** operate steam dryers with more than 125 PSI (8.62 bars) steam pressure. Excessive steam pressure can damage steam coil and/or harm personnel.
13. Replace leaking flexible hoses or other steam fixtures immediately. **DO NOT** operate the dryer with leaking flexible hoses. **PERSONAL INJURY MAY RESULT.**
14. **READ and FOLLOW ALL CAUTION and DIRECTION LABELS ATTACHED TO THE DRYER.**

WARNING: YOU MUST DISCONNECT and LOCKOUT THE ELECTRIC SUPPLY and THE GAS SUPPLY or THE STEAM SUPPLY BEFORE ANY COVERS or GUARDS ARE REMOVED FROM THE MACHINE TO ALLOW ACCESS FOR CLEANING, ADJUSTING, INSTALLATION, or TESTING OF ANY EQUIPMENT per OSHA (Occupational Safety and Health Administration) STANDARDS.

SECTION II

SPECIFICATIONS/DIMENSIONS and COMPONENT IDENTIFICATION

A. SPECIFICATIONS (GAS and STEAM Models)

Maximum Capacity (DRY WEIGHT)		200 lbs.	90.9 kg
Tumbler (BASKET) Diameter		62-1/2"	158.75 cm
Tumbler (BASKET) Depth		42"	106.7 cm
Tumbler (BASKET) Motor		3 HP	2.24 kw
Door Opening (DIAMETER)		36-3/4" w x 43" h	93.35 cm x 109.2 cm
Door Sill Height		36-1/2"	92.71 cm
Tumbler (BASKET) Volume		74.5 cu. ft.	2.11 cu. m.
Gas	Voltage Available	208-600v / 3Ø / 3, 4w 50/60 Hz	
	Heat Input	750,000 btu/hr	189,000 kcal/hr
	Blower Motor	7-1/2 HP	5.6 kw
	Approx. Weight (UNCRATED)	3,369	1,528.2 kg
	Airflow	5,300 cfm	150.16 cmm
	Inlet Size	1-1/4"	3.18 cm
Steam	Voltage Available	208-600v / 3Ø / 3, 4w 50/60 Hz	
	Blower Motor	15 HP	11.2 kw
	Approx. Weight (CRATED)	3,719 lbs.	1,687 kg
	Heat Input	27 Bhp	
	Steam Consumption	890 lbs./hr	404.5 kg/hr
	Airflow	6,500 cfm	184.16 cmm
	Inlet Size	2"	5.08 cm
	Operating Steam Pressure	125 PSI max	8.79 kg/sq cm
	Compressed Air Connection	1/8" F.P.T.	---

Shaded areas are stated in metric equivalents

IMPORTANT: Gas dryers and steam dryers *must be* provided with a clean, dry, regulated 80PSI +/-10 PSI (5.51 bars +/- 0.68 bars) air supply.

NOTE: ADC RESERVES THE RIGHT TO MAKE CHANGES IN SPECIFICATIONS AT ANY TIME, WITHOUT NOTICE or OBLIGATION.

B. ML-200 DIMENSIONS and COMPONENT LOCATION

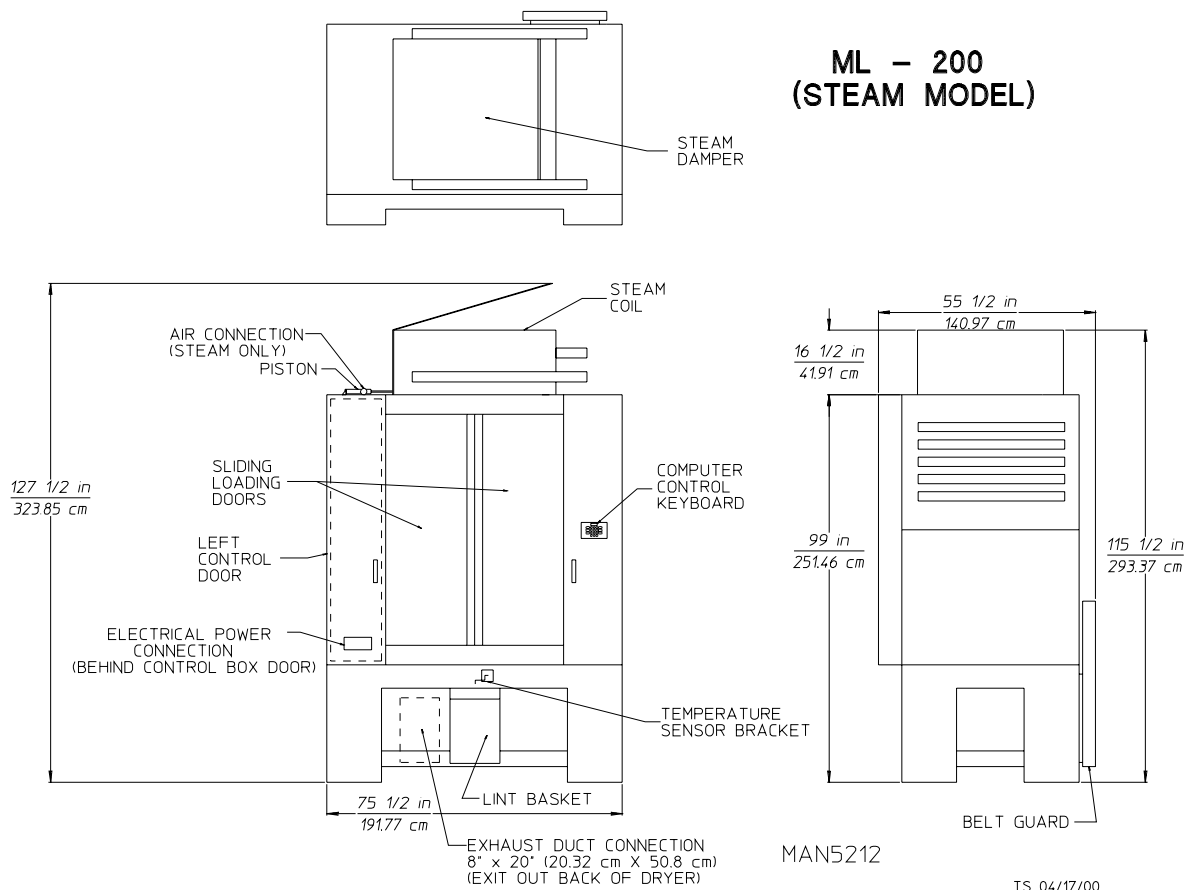
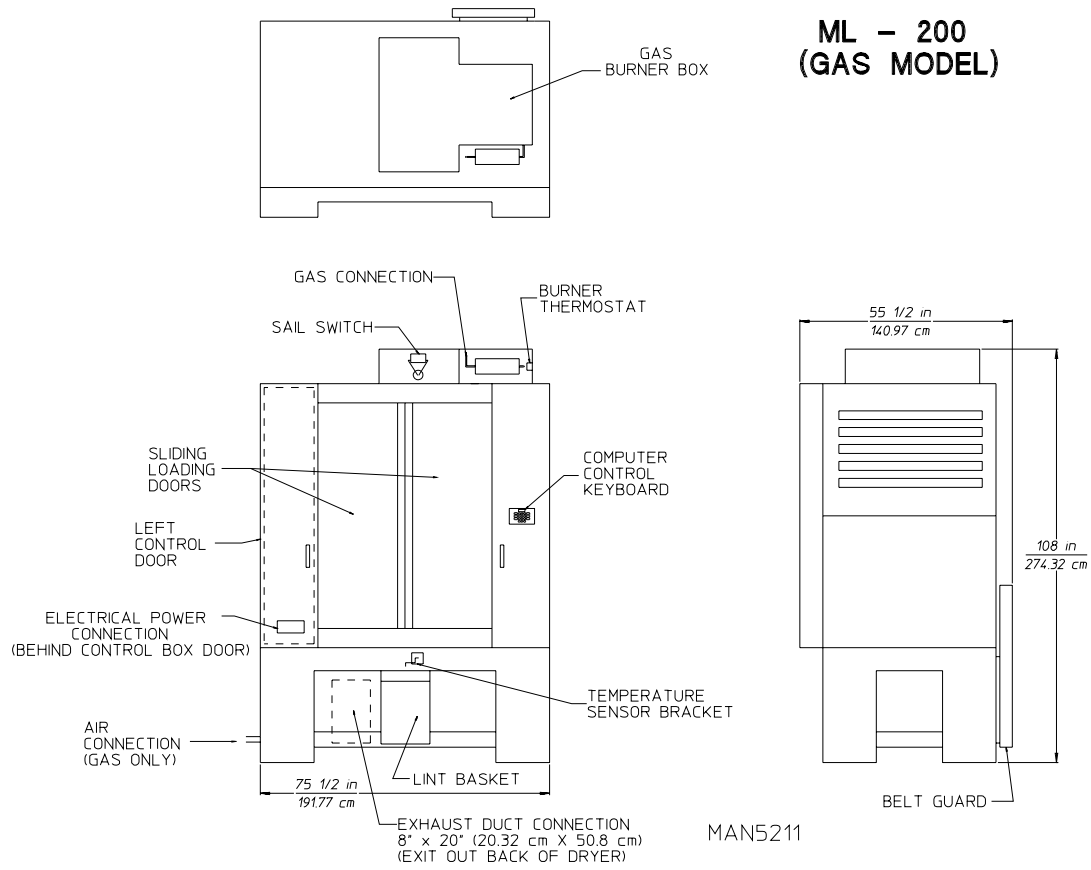

ML - 200 TUMBLER DRIVE SYSTEM

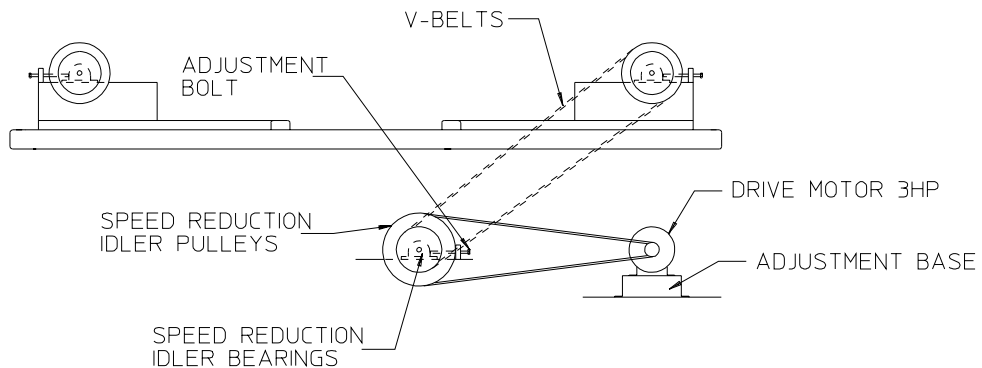
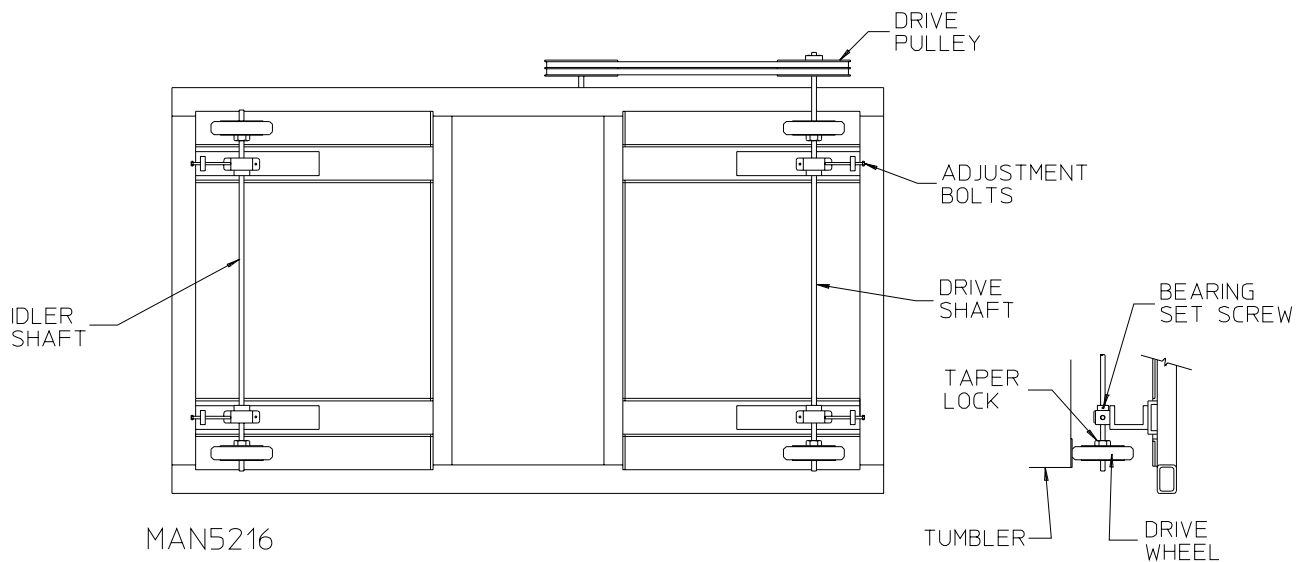

TS 04/17/00

WHEN REPLACING A DRIVE WHEEL:

1. ALWAYS CHANGE BOTH WHEELS ON A SHAFT.
2. MARK POSITION OF BEARINGS ON SUPPORTS. THIS WILL MAKE REASSEMBLY OF SHAFT AND CENTERING OF TUMBLER EASIER.
3. SHOVE BLOCKS OF WOOD UNDER TUMBLER TO TAKE IT'S WEIGHT OFF OF DRIVE WHEELS.
4. REMOVE BEARING HOLD DOWN BOLTS AND ADJUSTMENT BOLTS.
5. IF DRIVE SHAFT IS BEING REMOVED, TAKE OFF DRIVE PULLEY.
6. SLIDE COMPLETE SHAFT ASSEMBLY OUT OF SIDE OF DRYER.

SECTION III

INSTALLATION PROCEDURES

Installation in a proper location **should be** performed by competent technicians in accordance with local and state codes. In the absence of these codes, the installation **must conform** to applicable American National Standards: ANSI Z223.1-LATEST EDITION (National Fuel Gas Code) or ANSI/NFPA NO. 70-LATEST EDITION (National Electrical Code) or in Canada, the installation **must conform** to applicable Canadian Standards: CAN/CGA-B149.1-M91 (Natural Gas) or CAN/CGA-B149.2-M91 (L.P. Gas) or LATEST EDITION (for General Installation and Gas Plumbing) or Canadian Electrical Codes Parts 1 & 2 CSA C22.1-1990 or LATEST EDITION (for Electrical Connections).

A. REASSEMBLY OF DRYER

IMPORTANT: Always keep the tumbler (basket) section of the dryer in an upright position when moving it.

The ML-200 (gas model dryer) may be shipped one of two ways; as a complete unit fully assembled and ready for hookup or in two (2) pieces with the middle frame separated from the base. At installation, the middle frame will be lifted onto the base. Use cables through the eye bolts on top of the middle frame for lifting. Fasten the middle frame to the base by using the four (4) #3/8-16 bolts provided with the unit. Also, reconnect the V-belts, belt guard at the rear end of the unit, and reconnect the electrical plugs located in the front control boxes.

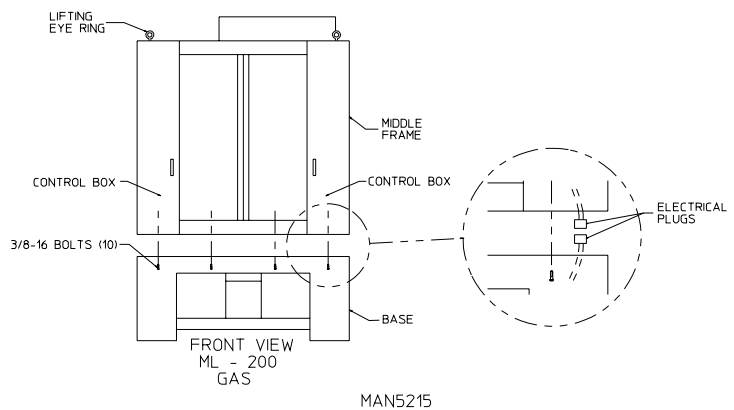

The ML-200 (steam models) can also be shipped with the middle frame separated from the base. In this case, follow the instructions for reassembly of the gas dryer. The steam dryer may also be shipped with the steam coil and damper piston removed. If this is the case, lift the steam coil on top of the middle frame, with the steam connection pipes facing the right side of the unit, and bolt the coil to the top of the middle frame using the #3/8-16 bolts provided. Also, bolt the damper piston and solenoid valve to the top of the middle frame using the bolts provided. There are three (3) panels that cover the front, right side, and rear of the steam coil. Fasten these in position.

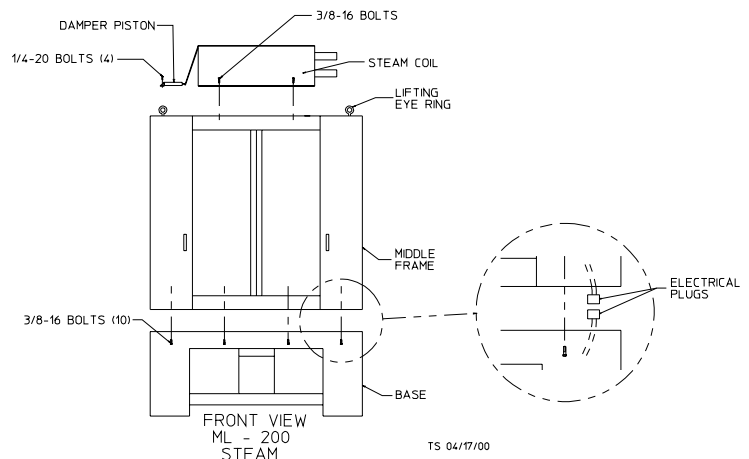

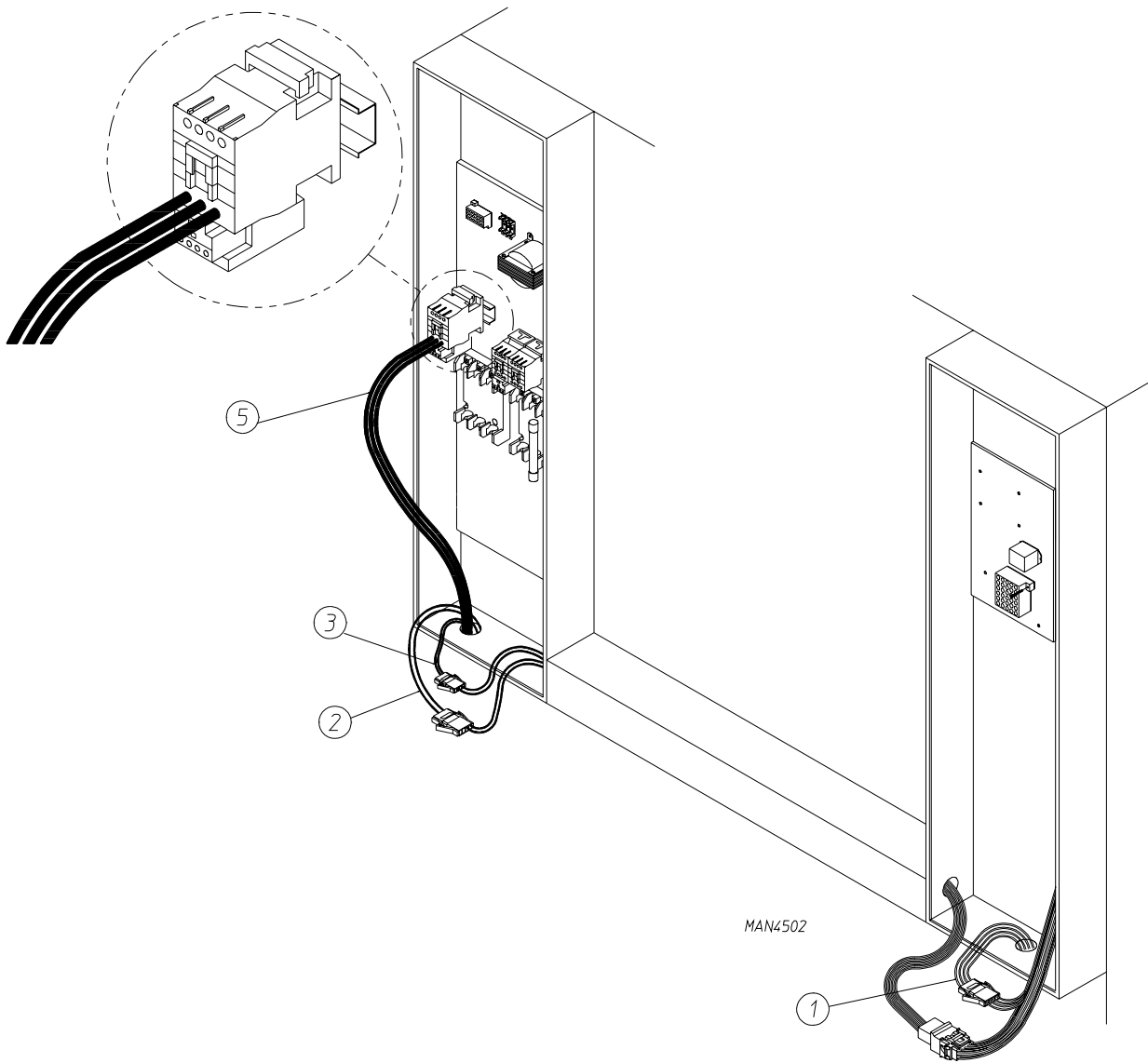

1. Reconnect the four (4) pin/socket connectors at the bottom of the right control box.
2. Reconnect the three (3) pin/socket connectors at the bottom of the left control box.
3. Reconnect the two (2) pin/socket connectors within the left control box.
4. Rewire the drive motor by inserting the three (3) black wires into the T1, T2, and T3 connections of the Telemecanique drive contactor.
5. Rewire the blower (impellor/fan) motor by inserting the three (3) blue wires into the T1, T2, and T3 connections of the Telemecanique blower contactor.

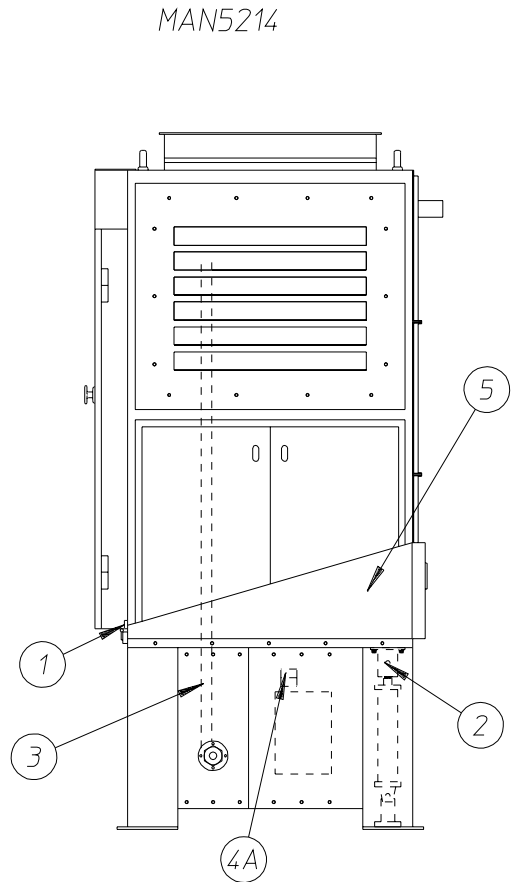
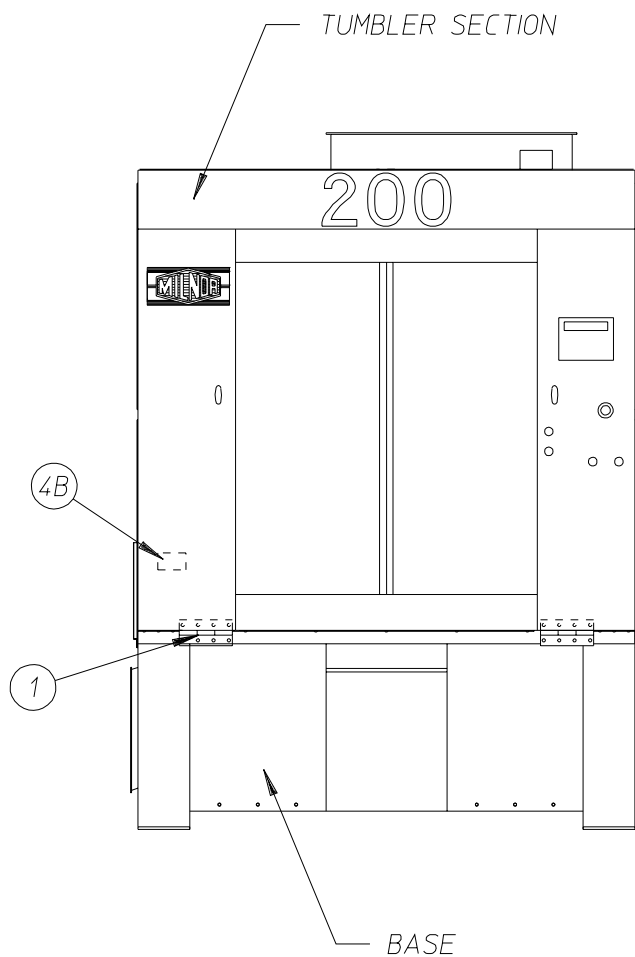

TS 04/17/00

RE-ASSEMBLY INSTRUCTIONS

- LIFT TUMBLER SECTION ONTO BASE.

1. USE EIGHT 1/2-13 BOLTS TO BOLT BASE HINGE TO TUMBLER SECTION.
2. USE FOUR 1/2-13 BOLTS TO BOLT PISTON CLEVIS TO THE BOTTOM OF THE TUMBLER SECTION.
3. RECONNECT INTERNAL GAS PIPE UNIONS. THE FLEXIBLE GAS HOSE SHOULD NOT HAVE ANY KINKS.
4. THERE ARE TWO ELECTRICAL RECONNECTIONS.

4A IS A PLUG LOCATED ON THE RIGHT SIDE OF THE BASE.

4B ARE THE DRIVER MOTOR WIRES WHICH MUST BE RECONNECTED INSIDE OF A JUNCTION BOX NEXT TO THE TUMBLER DRIVE MOTOR IN THE LEFT SIDE OF THE TUMBLER SECTION.

MAKE SURE BOTH RECONNECTED CABLES HAVE ENOUGH SLACK IN THEM TO ALLOW THE DRYER TO TILT FREELY.

5. RE-ATTACH TILT GUARD PANELS.

B. LOCATION REQUIREMENTS

The model ML-200 dryer requires 18-inches (45.72 cm) of space on each side of the dryer and 24-inches (60.96 cm) of space behind the unit for ease of maintenance. A minimum of 12-inches (30.48 cm) **must be** allowed between the top of a gas dryer and the ceiling. A ceiling height of 120-inches (304.8 cm) is required for gas dryers, and a ceiling height of 130-inches (330.2 cm) is required for a steam dryers. The dryer **must be** leveled for proper operation. If shimming is required, put metal shims which are the same size as the base feet. The dryer **must be** lagged to the floor.

Before installing the dryer, be sure the location conforms to local codes and ordinances.

1. The dryer **must be** installed on a sound level floor capable of supporting its weight. Carpeting **must be** removed from the floor area that the dryer is to rest on.

IMPORTANT: "The dryer *must be* installed on non-combustible floors only."

IMPORTANT: Dryer *should be* located where a minimum amount of exhaust duct **will be** necessary.

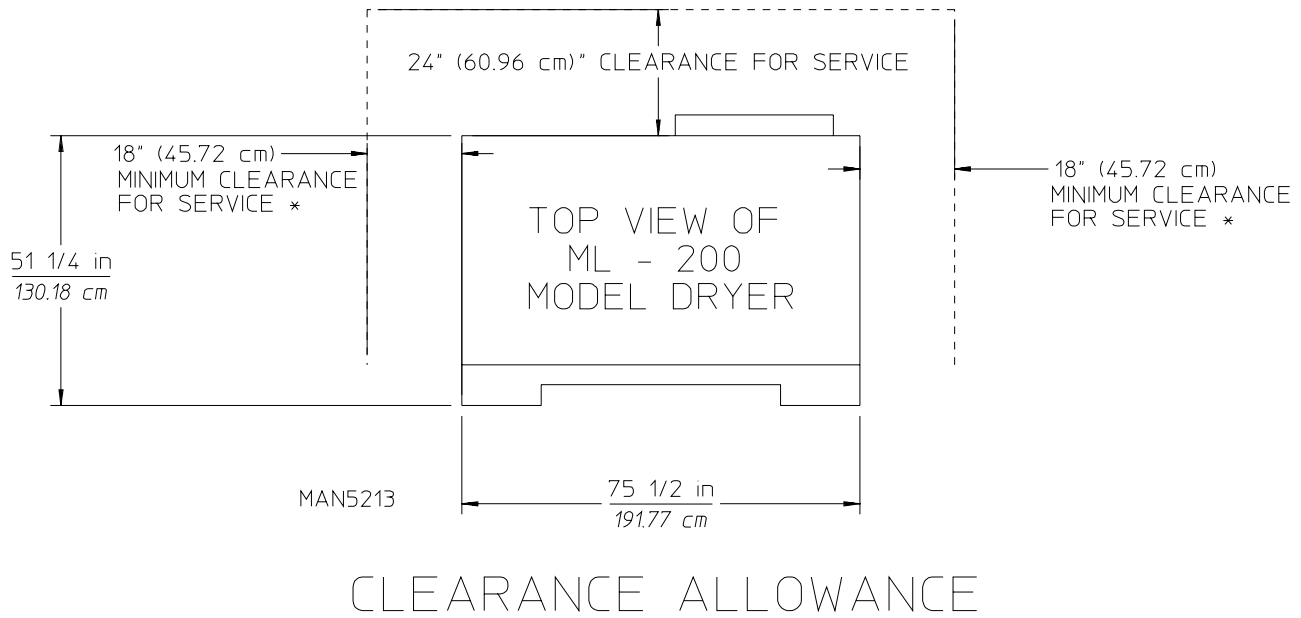

* 24" (60.96 cm) IS SUGGESTED

C. FRESH AIR SUPPLY

When the dryer is operating, it draws in room air, heats it, passes this air through the tumbler (basket), and exhausts it out of the building. Therefore, the room air **must be** continually replenished from the outdoors. If the make-up air is inadequate, drying time and drying efficiency will be adversely affected. Ignition problems and sail switch "fluttering" problems may result, as well as premature motor failure from overheating.

Air supply (make-up air) **must be** given careful consideration to assure proper performance of each dryer. An unrestricted source of air is necessary for each dryer. An airflow of 5,300 cfm (cubic feet per minute) - 150 cmm (cubic meters per minute) - **must be** supplied to each gas dryer and 6,500 cfm (cubic feet per minute) - 184 cmm - **must be** supplied to each steam dryer. As a general rule, an unrestricted air entrance from the outdoors (atmosphere) of a minimum of 5 square feet (0.46 square meters) for each gas dryer and a minimum of 6 square feet (0.56 square meters) is required for a steam dryer.

To compensate for the use of registers or louvers used over the openings, this make-up air area **must be** increased by approximately thirty-three percent (33%). Make-up air openings **should not be** located in an area directly near where exhaust vents exit the building.

It is not necessary to have separate make-up air openings for each dryer. Common make-up air is distributed equally to **ALL** dryers. However, they **must be** set up in such a manner that the make-up air is distributed equally to **ALL** the dryers.

IMPORTANT: Make-up air openings **should not be** located near duct work exhaust outlets. If the make-up air openings is too close to the exhaust outlet, lint and fumes may be drawn into the dryer area through these openings.

Allowances **must be** made for remote or constricting passageways or where dryers are located at excessive altitudes or predominantly low pressure areas.

IMPORTANT: Make-up air **must be** provided from a source free of dry cleaning fumes. Make-up air that is contaminated by dry cleaning solvent fumes will result in irreparable damage to motors and other components.

NOTE: Component failure due to dry cleaning solvent fumes will VOID THE WARRANTY.

D. EXHAUST REQUIREMENTS

1. General Exhaust Duct Work Information

Exhaust duct work **should be** designed and installed by a qualified professional. Improperly sized duct work will create excessive back pressure which results in slow drying, increased use of energy, over heating of the dryer, and shut down of the burner by the airflow (sail) switches, burner hi-limits, or tumbler (basket) hi-heat thermostats.

CAUTION: DRYER ***MUST BE*** EXHAUSTED TO THE OUTDOORS.

CAUTION: **IMPROPERLY SIZED or INSTALLED EXHAUST DUCT WORK CAN CREATE A POTENTIAL FIRE HAZARD.**

NOTE: When a dryer is exhausted separately, **it is recommended** that a back draft damper be installed.

NOTE: THE ML-200 ***MUST BE*** INDEPENDENTLY EXHAUSTED. COMMON DUCT WORK **IS NOT** ACCEPTABLE.

The duct work **should be** laid out in such a way that the duct work travels as directly as possible to the outdoors with as few turns as possible. Single or independent dryer venting is recommended.

The internal dimensions of the dryer's rectangular exhaust vent duct work is 8-inches by 20-inches (20.32 cm by 50.8 cm). The plant's exhaust duct **must be** at least 20-inches (50.8 cm) in diameter or for a rectangular duct have a cross-sectional area of 315 square inches (2,032 square centimeters). The duct work from the dryer to the outside exhaust outlet **should not exceed** 30 feet (9.14 meters). The shape of the duct work **is not** critical so long as the minimum cross-sectional area is provided. It is suggested that the use of 90° turns in ducting **be avoided**; use 45° angles instead. The radius of the elbows should preferably be 1-1/2 times the width or diameter of the duct. Excluding basket/dryer elbow connections or elbows used for outside protection from the weather, no more than two (2) elbows are used, the cross section area of the duct work **must be** increased.

ALL duct work **should be** smooth inside with no projections from sheet metal screws or other obstructions which will collect lint. When adding ducts, the ducts to be added should overlap the duct to which it is connected. **ALL** duct work joints **must be** taped to prevent moisture and lint from escaping into the building. Additionally, inspection doors **should be** installed at strategic points in the exhaust duct work for periodic inspection and clean-out of lint from the duct work.

IMPORTANT: Exhaust back pressure measured by a manometer in the exhaust duct ***should not exceed*** 0.3 inches of water column (0.74 mb).

NOTE: Where the exhaust duct work passes through a wall, ceiling, or roof made of combustible materials, the opening ***must be*** 2-inches (5.08 cm) larger (all the way around) than the duct. The duct ***must be*** centered within this opening.

a. Outside Duct Work Protection

- 1) To protect the outside end of horizontal duct work from the weather, a 90° elbow bent downward **should be** installed where the exhaust exits the building. If the duct work travels vertically up through the roof, it **should be** protected from the weather by using a 180° turn to point the opening downward. In either case allow at least twice the diameter of the duct between the duct opening and the nearest obstruction.

IMPORTANT: *DO NOT* use screens or caps on the outside of opening of exhaust duct work.

VERTICAL DUCTING

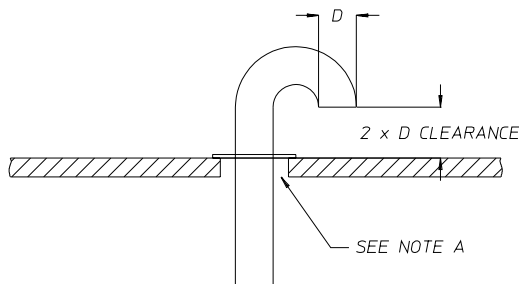

HORIZONTAL DUCTING

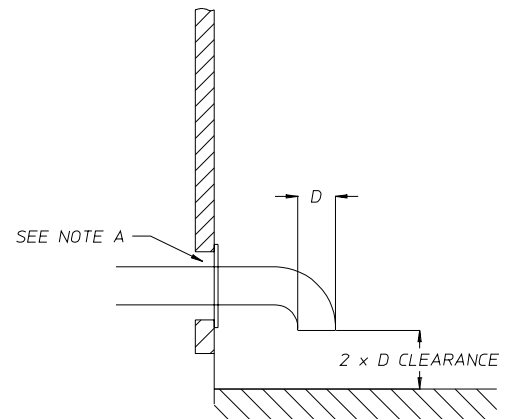

NOTE *A*: OPENING MUST BE TWO (2) INCHES (5.08 CM) LARGER THAN DUCT (ALL THE WAY AROUND). THE DUCT MUST BE CENTERED WITHIN THIS OPENING.

MAN4706

E. COMPRESSED AIR SUPPLY SYSTEM

A clean, dry, regulated air supply of 80 PSI (5.51 bars) compressed air **must be** supplied to the dryer. The connection size is 1/8-inch N.P.T. No air filtering or pressure regulating devices are provided with the standard ML-200 Non-Tilt dryer.

1. Gas Dryers

The air line supply connection is made into the 1/8-inch N.P.T. port on the air jet solenoid valve which is located in the base of the dryer. (Refer to the **illustration** below.)

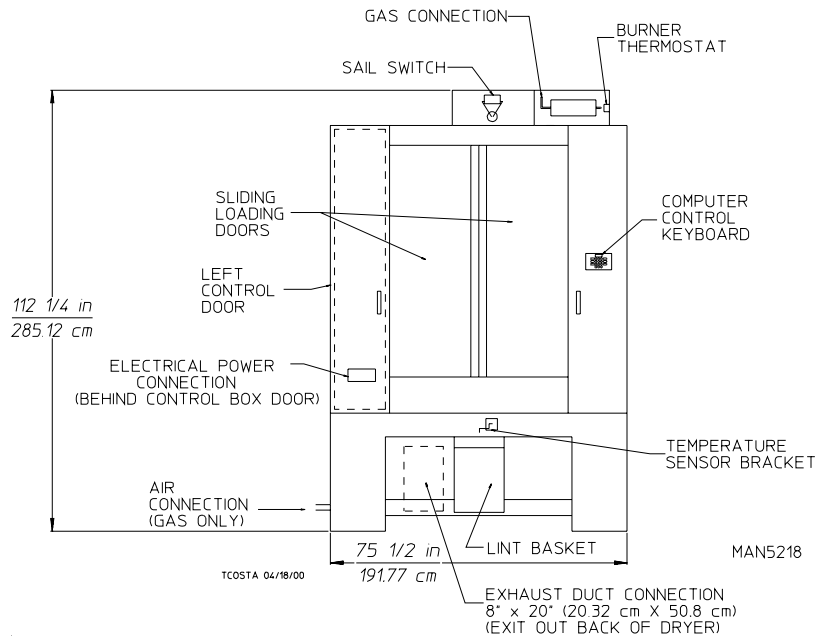

2. Steam Dryers

The air line supply connection is made into the 1/8-inch N.P.T. tee which is located at the left hand side of the top of the dryer. (Refer to the **illustration** below.)

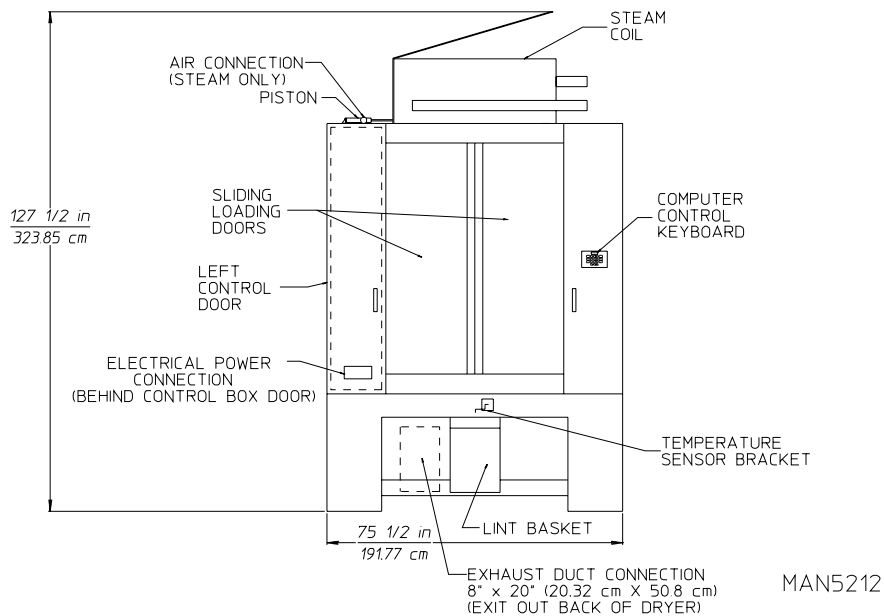

F. ELECTRICAL INFORMATION

1. Electrical Requirements

It is your responsibility to have **ALL** electrical connections made by a properly licensed and competent electrician to assure that the electrical installation is adequate and conforms with local and state regulations or codes. In the absence of such codes, **ALL** electrical connections, material, and workmanship **must conform** to the applicable requirements of the National Electrical Code ANSI/NFPA NO. 70-LATEST EDITION or in Canada, the Canadian Installation Codes CAN/CGA-B149.1-M91 (Natural Gas) or CAN/CGA-B149.2-M91 (L.P. Gas) or LATEST EDITION.

IMPORTANT: Failure to comply with these codes or ordinances, and/or the requirements stipulated in this manual can result in personal injury or component failure.

NOTE: Component failure due to improper installation will VOID THE WARRANTY.

Each dryer **should be** connected to an independently protected branch circuit. The dryer **must be** connected with copper wire ONLY. **DO NOT use aluminum wire which could cause a fire hazard.** The copper conductor wire/cable **must be** of proper ampacity and insulation in accordance with electric codes for making **ALL** service connects.

NOTE: The use of aluminum wire will VOID THE WARRANTY.

2. Electrical Service Specifications

MLG-200 (Gas)

7.5 Hp Blower/3 Hp Drive Motor

ELECTRIC SERVICE SPECIFICATION (PER DRYER)

IMPORTANT: 208 VAC and 230 VAC ARE NOT THE SAME. When ordering, *specify exact voltage*.

- NOTES:**
- A. Fuse ratings are dual element-time delay-current limiting, class RK1 or RK5 **ONLY**.
 - B. Circuit breakers are thermal magnetic (industrial) type **ONLY**. For others, calculate/verify correct breaker size according to appliance amp draw rating and type of breaker used.
 - C. Circuit breakers for 3Ø dryers **must be** 3-pole type.

SERVICE VOLTAGE	PHASE	WIRE SERVICE	APPROX. AMP DRAW		MINIMUM WIRE SIZE*	FUSING Dual Element Time Delay	CIRCUIT BREAKER
			60 Hz	50 Hz			
208	3Ø	3/4	37	---	4	60	80
230	3Ø	3	36	---	4	60	80
380	3Ø	3/4	---	20	8	30	40
416	3Ø	3/4	---	19	8	30	40
460	3Ø	3/4	18	---	8	30	40

* AWG Stranded Type Wire...for individual lengths less than 100 feet (30.48 meters).

WARNING: 208 VAC and 230 VAC ARE NOT THE SAME. Any damage done to dryer components due to improper voltage connections will automatically VOID THE WARRANTY.

IMPORTANT: The dryer *must be* connected to the electrical supply shown on the data label that is affixed to the back of the dryer, at the upper right hand corner. In case of 208 VAC or 230 VAC, the supply voltage **must match** the electric service specifications of the data label *exactly*.

NOTE: ADC RESERVES THE RIGHT TO MAKE CHANGES IN SPECIFICATIONS AT ANY TIME, WITHOUT NOTICE or OBLIGATION.

MLS-200 (Steam) 15 Hp Blower/3 Hp Drive Motor

ELECTRIC SERVICE SPECIFICATIONS (PER DRYER)

IMPORTANT: 208 VAC and 230 VAC ARE NOT THE SAME. When ordering, *specify exact voltage*.

NOTES: A. Fuse ratings are dual element-time delay-current limiting, class RK1 or RK5 **ONLY**.
 B. Circuit breakers are thermal magnetic (industrial) type **ONLY**. For others, calculate/verify correct breaker size according to appliance amp draw rating and type of breaker used.
 C. Circuit breakers for 3 dryers **must be** 3-pole type.

SERVICE VOLTAGE	PHASE	WIRE SERVICE	APPROX. AMP DRAW		MINIMUM WIRE SIZE*	FUSING Dual Element Time Delay	CIRCUIT BREAKER
			60 Hz	50 Hz			
208	3Ø	3/4	54	---	4	80	90
230	3Ø	3	48	---	4	80	90
380	3Ø	3/4	---	29	10	40	60
416	3Ø	3/4	---	27	10	40	60
460	3Ø	3/4	25	---	10	40	60

* AWG Stranded Type Wire...for individual lengths less than 100 feet (30.48 meters).

WARNING: 208 VAC and 230 VAC ARE NOT THE SAME. Any damage done to dryer components due to improper voltage connections will automatically VOID THE WARRANTY.

IMPORTANT: The dryer *must be* connected to the electrical supply shown on the data label that is affixed to the back of the dryer, at the upper right hand corner. In case of 208 VAC or 230 VAC, the supply voltage **must match** the electric service specifications of the data label *exactly*.

NOTE: ADC RESERVES THE RIGHT TO MAKE CHANGES IN SPECIFICATIONS AT ANY TIME, WITHOUT NOTICE or OBLIGATION.

3. Electrical Connections

NOTE: A wiring diagram is included with each dryer and is affixed to the panel inside the right side control cabinet.

The only electrical input connections to the dryer are the 3-phase (3Ø) power leads (L1, L2, and L3), GROUND, and in the case of 4 wire service, the Neutral. These electrical connections are made at the power distribution block located in the left side control cabinet.

Providing local codes permit, power connections to the dryer can be made by the use of a flexible Underwriters Laboratory listed cord/pigtail (wire size **must conform** to rating of the dryer), or the dryer can be hard wired directly to the service breaker. In **ALL** cases, a strain relief **must be** used where the wire(s) enter the dryer electrical service (relay) box.

NOTE: A CIRCUIT SERVING EACH DRYER MUST BE PROVIDED.

4. Main Grounding

Grounding (earth) connections **must be** provided and installed in accordance with state and local codes. In the absence of these codes, grounding **must conform** to applicable requirements of the National Electrical Code ANSI/NFPA NO. 70-LATEST EDITION, or in Canada, the Canadian Electrical Codes Parts 1 & 2 CSA C22.1-1990 or LATEST EDITION. The ground connection may be to a proven earth ground at the location service panel.

NOTE: A grounding connection (terminal lug) is provided in the dryer at the left side control cabinet.

For added personal safety, when possible, it is suggested that a separate ground wire (sized per local codes) be connected from the ground connection of the dryer to a grounded cold water pipe. **DO NOT ground to a gas or hot water pipe.** The grounded cold water pipe **must have** metal to metal connections **ALL** the way to electrical ground. If there are any nonmetallic interruptions, such as a meter, pump, plastic, rubber, or other insulating connectors, they **must be** jumped out with no. 4 copper wire and securely clamped to bare metal at both ends.

IMPORTANT: For personal safety and proper operation, the dryer **must be** grounded. For proper operation of the microprocessor (computer), an earth (zero) ground is required.

NOTE: Grounding via metallic electrical conduit (pipe) **is not recommended.**

G. GAS INFORMATION

It is your responsibility to have **ALL** plumbing connections made by a qualified professional to assure that the gas plumbing installation is adequate and conforms with local and state regulations or codes. In the absence of such codes, **ALL** plumbing connections, materials, and workmanship **must conform** to the applicable requirements of the National Fuel Gas Code ANSI Z223.1-LATEST EDITION, or in Canada, the Canadian Installation Codes CAN/CGA-B149.1-M91 (Natural Gas) or CAN/CGA-B149.2-M91 (L.P. Gas) or LATEST EDITION.

IMPORTANT: Failure to comply with these codes or ordinances, and/or the requirements stipulated in this manual, can result in personal injury and improper operation of the dryer.

The dryer and its individual shut-off valve **must be** disconnected from the gas supply piping system during any pressure testing of that system at test pressures in excess of 1/2 psig (3.5 kPa). The dryer **must be** isolated from the gas supply piping system by closing its individual manual shut-off valve during any pressure testing of the gas supply piping system at test pressures equal to or less than 1/2 psig (3.5 kPa).

IMPORTANT: Failure to isolate or disconnect dryer from supply as noted can cause irreparable damage to the gas valve VOIDING THE WARRANTY.

WARNING: FIRE or EXPLOSION COULD RESULT.

1. Gas Supply

The gas dryer installation **must meet** the American National Standard...National Fuel Gas Code ANSI Z223.1-LATEST EDITION, or in Canada, the Canadian Installation Codes CAN/CGA-B149.1 M91 (Natural Gas) or CAN/CGA-B149.2-M91 (L.P. Gas) or LATEST EDITION, as well as local codes and ordinances and **must be** done by a qualified professional.

NOTE: Undersized gas piping will result in ignition problems, slow drying, increased use of energy, and can create a safety hazard.

The dryer **must be** connected to the type of heat/gas indicated on the dryer label affixed behind the right control box door. If this information does not agree with the type of gas available, **DO NOT operate the dryer**. Contact the distributor who sold the dryer or the **ADC** factory.

IMPORTANT: Any burner changes or conversions **must be** made by a qualified professional.

The input ratings shown on the dryer data label are for elevations up to 2,000 feet (609.6 meters), unless elevation requirements over 2,000 feet (609.6 meters) were specified at the time the dryer order was placed with the factory. The adjustment or conversion of the dryers in the field for elevations over 2,000 feet (609.6 meters) are made by changing each burner orifice. If this conversion is necessary, contact the distributor who sold the dryer or contact the **ADC** factory.

2. Technical Gas Data

a. Gas Specifications

	TYPE OF GAS			
	Natural		Liquid Propane	
Manifold Pressure*	3.5 inches W.C.	8.7 mb	10.5 inches W.C.	26.1 mb
Inline Pressure	6.0 - 12.0 inches W.C.	14.92 - 29.9 mb	10.5 inches W.C.	26.1 mb

Shaded areas are stated in metric equivalents

* Measured at gas valve pressure tap when the gas valve is on.

b. Gas Connections:

Inlet connection ---- 1-1/4 inch N.P.T.

Inlet Supply Size ---- 1-1/2 inch N.P.T.

Btu/hr input ----- 750,000 (189,000 kcal/hr)

1) Natural Gas

Regulation is controlled by the dryers gas valve internal regulator. Incoming supply pressure **must be** consistently between a minimum of 6.0 (14.92 mb) and a maximum of 12.0 inches water column (29.9 mb) pressure.

2) Liquid Propane (L.P.) Gas

Dryers made for use with liquid propane (L.P.) gas have both of their gas valve's internal pressure regulators blocked open so that the gas pressure **must be** regulated upstream of the dryer. The pressure is measured at each gas valve pressure tap **must be** a consistent 10.5 inches water column (W.C.) - 26.1 mb. There is no regulator or regulation provided in an L.P. gas dryer. The water column **must be** regulated at the source (L.P. tank) or external regulator/regulation **must be** added to each dryer.

MODEL NUMBER	BTU Per Hour Rating	kcal/hr Rating	TYPE OF GAS						L.P. Conversion Kit Part Number
			Natural			Liquid Propane			
			Qty.	D.M.S.*	Part Number	Qty.	D.M.S.*	Part Number	
MLG-200**	750,000	189,000	5	#1	140840	5	#28	140821	880754

Shaded area is stated in metric equivalent

* D.M.S. (Drill Material Size) equivalents are as follows:

Natural Gas #1 = .2280" (5.7912 mm)

Liquid Propane #28 = .1405" (3.5687 mm)

3. Piping/Connections

ALL components/materials **must conform** to National Fuel Gas Code Specifications. It is important that gas pressure regulators meet applicable pressure requirements and that gas meters be rated for the total amount of **ALL** the appliance BTU's being supplied.

The dryer is provided with a 1-1/4" F.P.T. inlet pipe connections extending out of the top of the burner boxes. The minimum pipe size (supply line) to the dryer is 1-1/2" N.P.T. For ease of servicing, the gas supply line to each dryer **must have** its own shut off valve.

The size of the main gas supply line (header) will vary depending on the distance this line travels from the gas meter or, in the case of L.P. (liquid propane) gas, the supply tank, other gas-operated appliances on the same supply line, etc. Specific information regarding supply line size **should be** determined by the gas supplier.

NOTE: Undersized gas supply piping can create a low or inconsistent pressure which will result in erratic operation of the burner ignition system.

Consistent gas pressure is essential at **ALL** gas connections. It is recommended that a 1-1/4" (3.18 cm) pipe gas loop be installed in the gas supply line serving a bank of dryers. An in-line pressure regulator **must be** installed in the supply line (header) if the (natural) gas pressure exceeds 12.0 inches of water column (29.9 mb) pressure.

IMPORTANT: A water column pressure of 3.5 inches (8.7 mb) for natural gas and 10.5 inches (26.1 mb) for L.P. dryers is required at the gas valve pressure tap of each dryer for proper and safe operation.

A 1/8" N.P.T. plugged tap, accessible for a test gauge connection, **must be** installed in the main gas supply line immediately upstream of each dryer.

IMPORTANT: Pipe joint compounds that resist the action of natural and L.P. gases **must be** used.

IMPORTANT: Test **ALL** connections for leaks by brushing on a soapy water solution (liquid detergent works well).

WARNING: NEVER TEST FOR GAS LEAKS WITH A FLAME!!!

ALL components/materials **must conform** to National Fuel Gas Code Specifications ANSI Z223.1-LATEST EDITION.

It is important that gas pressure regulators meet applicable pressure requirements, and gas meters be rated for the total amount of **ALL** the appliance Btu's being supplied.

IMPORTANT: The dryer and its individual shut-off valve **must be** disconnected from the gas supply piping system during any pressure testing of that system at test pressures in excess of 1/2 psig (3.5 kPa).

NOTE: The dryer **must be** isolated from the gas supply piping system by closing its individual manual shut off valve during any pressure testing of gas supply piping system at test pressures equal to or less than 1/2 psig (3.5 kPa).

TYPICAL NATURAL GAS INSTALLATION

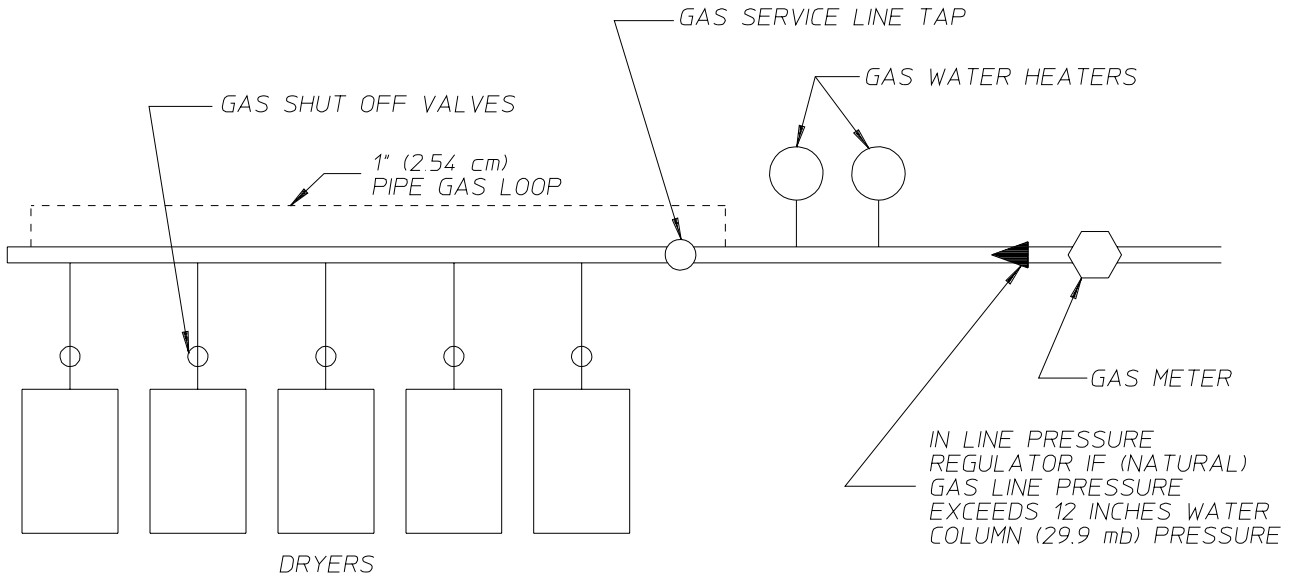

TYPICAL L.P. GAS INSTALLATION

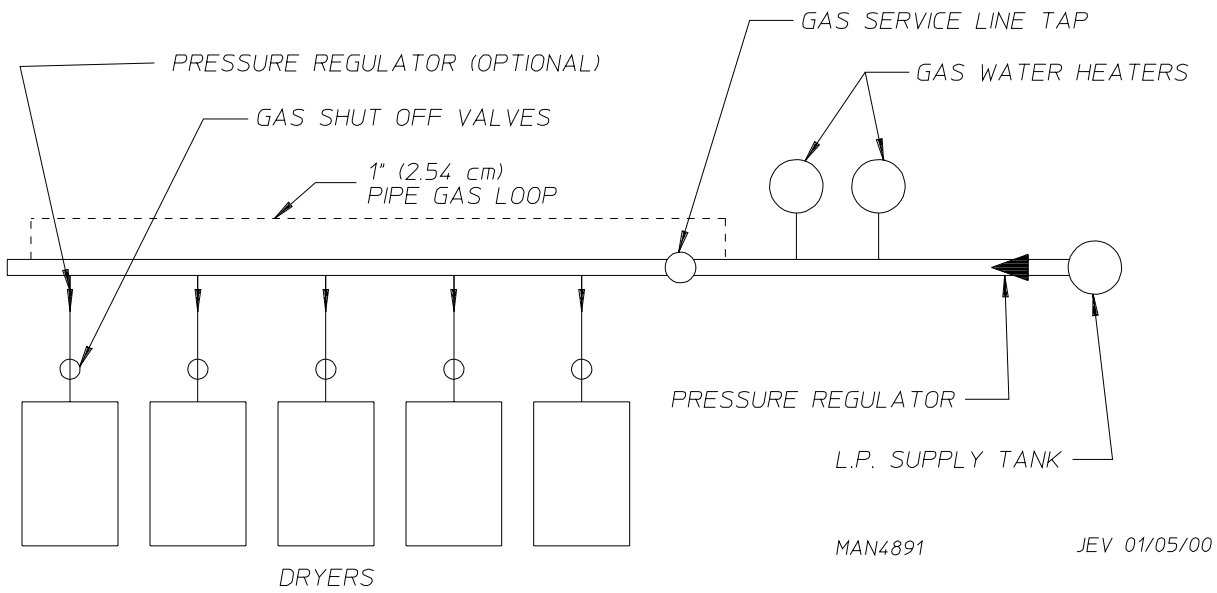

MAN4891

JEV 01/05/00

H. STEAM INFORMATION

It is your responsibility to have **ALL** steam plumbing connections made by a qualified professional to assure that the installation is adequate and conforms with local and state regulations or codes.

IMPORTANT: Failure to comply with the requirements stipulated in this manual can result in component failure which will VOID THE WARRANTY.

NOTE: The MLS-200 is manufactured with a pneumatic (piston) damper system which requires an external supply of air (80 psi +/- 10 psi [5.51 bars +/- 0.68 bars]). See **Steam Damper Air System Connections Section H, item 3.**

1. Steam Coil PH Level

The normal PH level for copper type steam coils **must be** maintained between a value of 8.5 to 9.5. For steel type steam coils the PH level **must be** maintained between a value of 9.5 to 10.5. These limits are set to limit the acid attack of the steam coils.

IMPORTANT: Coil failure due to improper PH level will VOID THE WARRANTY.

2. Steam Requirements - High Pressure

Inlet ----- 2-inch supply line connection

Return ----- 2-inch return line connection

OPERATING STEAM PRESSURE, HIGH PRESSURE		
Maximum	125 psig	8.79 kg/sq cm
Minimum	100 psig	7.03. kg/sq cm
Heat Input (Normal Load)	27 Bhp	
Consumption (Approximate)	800 lbs/hr	362 kg/hr

Shaded areas are in metric equivalents

3. Installation Instructions

To insure that an adequate supply of steam is provided, be sure that the steam supply and steam return lines are sized and laid out as stipulated in this manual. Inadequate steam supply and steam return lines or improper steam plumbing will result in poor performance and can cause component failure. Clean, dry, regulated steam **must be** provided to the dryer.

IMPORTANT: Steam coil failure due to water hammer by wet steam will VOID THE WARRANTY.

- a. The presence of the condensate in the steam supply will cause water hammer and subsequent heat exchanger (steam coil) failure. The steam supply connection into the main supply line **must be** made within a minimum 10-inch (25.4 cm) riser. This will prevent any condensate from draining towards the dryer.

- b. The steam supply piping to the dryer **must include** a 12-inch (30.48 cm) rise along with a drip trap and check valve. This will prevent any condensate from entering the steam coil.
- c. Flexible hoses or couplings **must be** used. The dryer vibrates slightly when it runs and this will cause the steam coil connections to crack if they are hard piped to the supply and return mains.
- d. Shut-off valves for each dryer **should be** installed in the supply, return, and drip trap return lines. This will allow the dryer to be isolated from the supply and return mains if the dryer needs maintenance work.
- e. Install an inverted bucket steam trap and check valve for each unit at least 12-inches (30.48 cm) below steam coil as close to the coil as possible.
- f. A vacuum breaker **should be** installed in the piping. This will prevent the condensing steam from causing a vacuum inside the coil and possibly damaging the coil.
- g. The supply and return lines **should be** insulated. This will save energy and provide for safety of the operator and maintenance personnel.
- h. Water pockets in the supply line, caused by low points, will provide wet steam to the coil possibly causing coil damage. **ALL** horizontal runs of steam supply piping **should be** pitched 1/4-inch (6.35 mm) for every 1 foot (0.30 meters) back towards the steam supply header causing any condensate in the line to drain to the header. Install a bypass trap in any low point to eliminate wet steam.

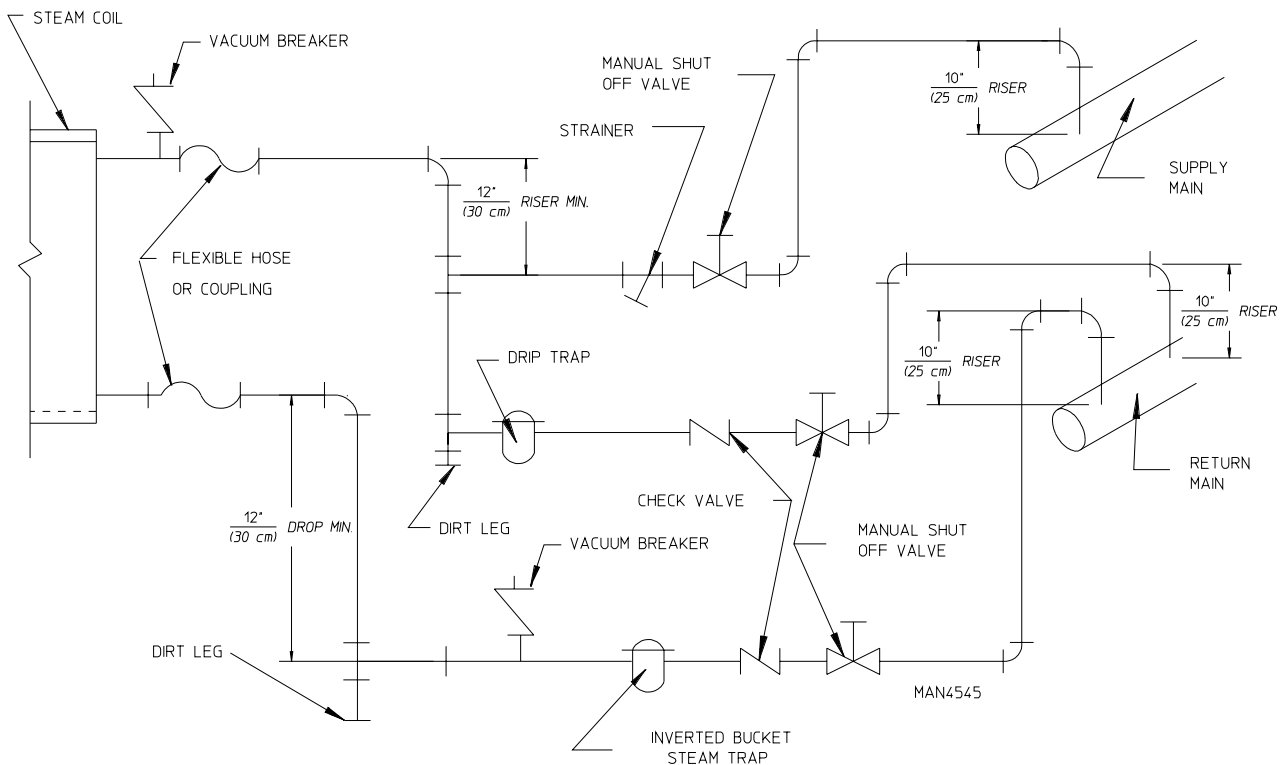

4. Steam Damper Air System Connections

The ML-200 is manufactured with a pneumatic (piston) damper system which requires an external supply of compressed air. The air connection is made to the steam damper solenoid valve which is located on the outer top, at the rear left hand corner of the dryer.

a. Air Requirements

Compressed Air Supply	Air Pressure	
Normal	80 PSI	5.51 bars
Minimum Supply	70 PSI	4.82 bars
Maximum Supply	90 PSI	6.20 bars

Shaded areas are stated in metric equivalents

b. Air Connection

Air connection to system --- 1/8-inch F.P.T.

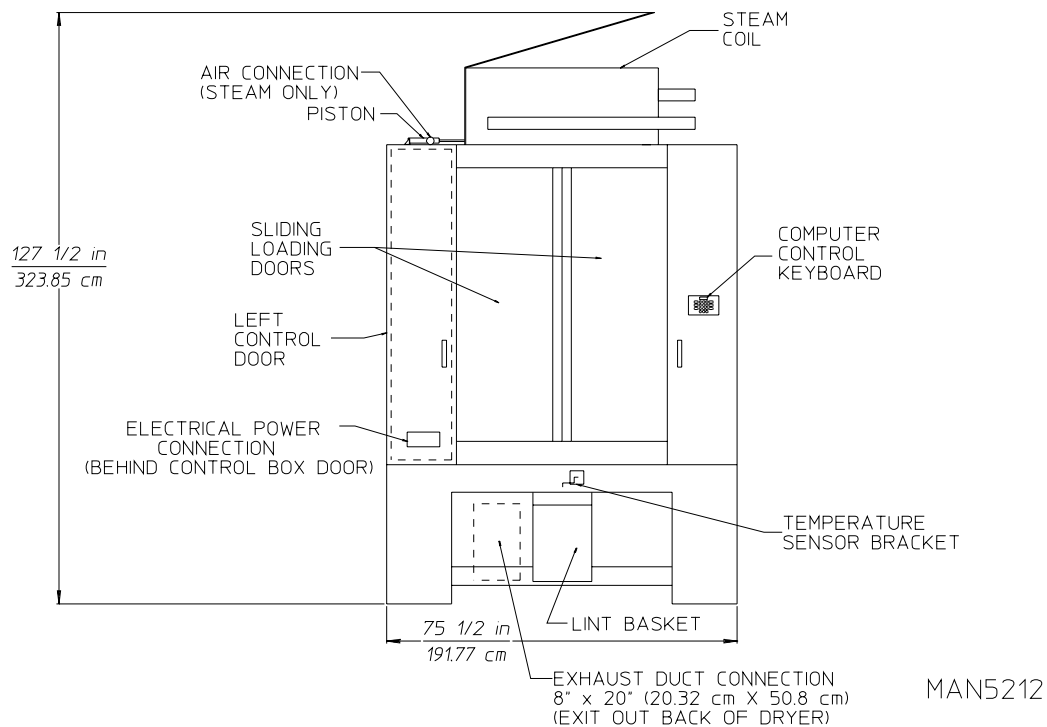

- c. No air regulation is provided with the dryer. External regulation of **80 PSI (5.51 bars)** **must be** provided. It is suggested that a regulator/filter gauge arrangement be added to the compressed air line just before the dryer connection. This is necessary to insure that correct and clean air pressure is achieved.

5. Steam Damper System Operation

The MLS-200 steam damper, as shown in **Diagram 1** on **page 28**, allows the coil to stay constantly charged eliminating repeated expansion and contraction. When the damper is opened, the air immediately passes through the already hot coil, providing instant heat to start the drying process. When the damper is closed, ambient air is drawn directly into the tumbler (basket), allowing a rapid cool down.

Diagram 1 shows the damper in the heating (open) mode, allowing heat into the tumbler (basket).

Diagram 2 shows the damper in the cool down (closed) mode, pulling ambient air directly into the tumbler (basket) without passing through the coils.

NOTE: With the dryer off or with no air supply, the damper is in the cool down mode as shown in **Diagram 2**.

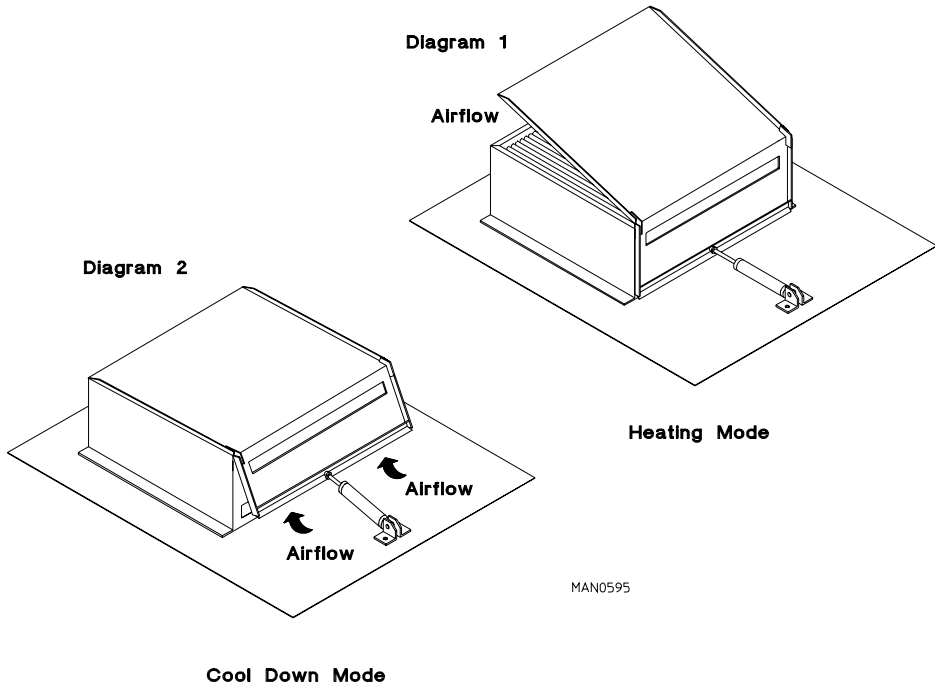

6. Steam Damper Air Piston (Flow Control) Operation Adjustment

Steam damper operation was tested and adjusted prior to shipping at 80 PSI (5.51 bars). If steam damper adjustment is necessary, locate the flow control valve and make the necessary adjustments as noted below.

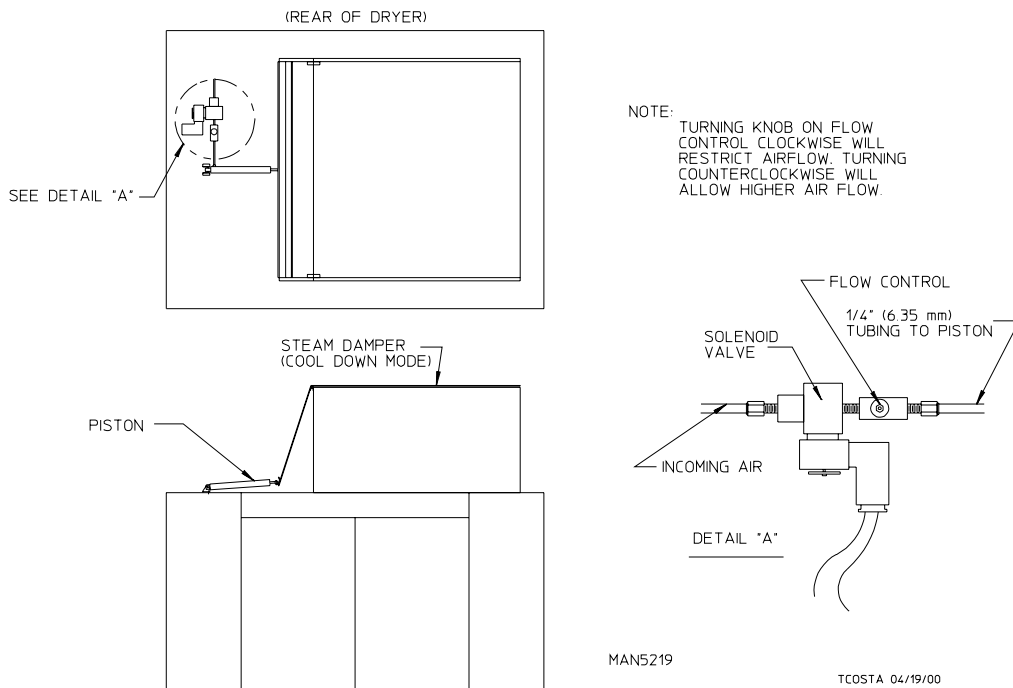

I. PREPARATION FOR OPERATION/START-UP

The following items **should be** checked before attempting to operate the dryer:

1. Read **ALL** "CAUTION," "WARNING," and "DIRECTION" labels attached to the dryer.
2. Check incoming supply voltage to be sure that it is the same as indicated on the dryer data label affixed behind the right control box door. In case of 208 VAC or 230 VAC for dryers with sprinkler option verify 1Ø voltage is correct, the supply voltage **must match** the electric service **exactly**.
3. **GAS MODELS** - check to assure that the dryer is connected to the type of heat/gas indicated on the dryer data label.
4. **GAS MODELS** - the sail switch damper assembly was installed and adjusted at the factory prior to shipping. However, each sail switch adjustment **must be** checked to assure that this important safety control is functioning.
5. Check to be sure drive belts between idler pulley and motor pulley have been reconnected.

NOTE: The drive belts were disconnected at factory prior to shipment.

6. **GAS MODELS** - be sure that **ALL** gas shut-off valves are in the open position.
7. Be sure **ALL** side and base panels are on the dryer.
8. Check **ALL** service doors to assure that they are closed and secure.
9. Be sure lint drawer is securely in place.

NOTE: LINT DRAWER *MUST BE* ALL THE WAY IN PLACE TO ACTIVATE SAFETY SWITCH OTHERWISE THE DRYER WILL NOT START.

10. Rotate the tumbler (basket) by hand to be sure it moves freely.
11. Check bolts, nuts, screws, terminals, and fittings for security.
12. Check to insure air supply (80 PSI [5.51 bars]) is connected to the dryer.
13. **STEAM MODELS** - check to insure **ALL** steam shut-off valves are open.

J. PREOPERATIONAL TESTS

ALL dryers are thoroughly tested and inspected before leaving the factory. However, a preoperational test **should be** performed before the dryer is publicly used. It is possible that adjustments have changed in transit or due to marginal location (installation) conditions.

1. Turn on electric power to the dryer.
2. Make sure loading doors are closed and the lint drawer is closed.
3. Microprocessor (computer) system operational test -- to start the dryer;
 - a. Display will read "FILL."
 - b. Press "E" (preprogrammed) cycle key on the touchpad of the keyboard.
 - c. Display will quickly read..."Ld30," "Lc04," and "F180" (unless special programs requested). These codes mean that the dryer is in the timed mode and will operate with heat of 180° F (Fahrenheit) - 82° C (Celsius) - for 30 minutes drying time and have a 4 minute cool down period.
 - d. Dryer will now start, and the L.E.D. (light emitting diode) display will read "Dr30" (dry mode for 30 minutes) and count downwards in minutes.

NOTE: Dryer can be stopped at any time by opening the main door or by pressing the "CLEAR/STOP" key. To restart the dryer, press the "ENTER/START" key or a preprogrammed cycle key (i.e., "E").

NOTE: Pressing touchpad key "A", "B", "C", "D", and "F" will also start the dryer. The six preprogrammed drying cycles ("A" thru "F") have been stored in the microprocessor (computer's) memory. Refer to the Programming Manual supplied with the dryer for these preprogrammed cycles.

4. Check to insure that the tumbler (basket) starts in the clockwise (CW) direction. Additionally, check the direction of the blower motor to insure that it rotates in the counterclockwise (CCW) direction as viewed from the left side of the dryer. If it does, the phasing is correct. If the phasing is incorrect, reverse two (2) of the leads at L1, L2, or L3 of the power supply connections made to the dryer.

IMPORTANT: Dryer blower motor and impellor/fan shaft as viewed from the left side of the dryer **must turn** in the counterclockwise (CCW) direction, otherwise the dryer efficiency **will be** drastically reduced, and premature component failure can result.

5. Heat Circuit Operational Test

a. Gas Models

- 1) When the dryer is first started (during initial start-up), the burners have a tendency not to ignite on the first attempt. This is because the gas supply piping is filled with air, so the dryer may have to be stopped and restarted several times for this air to be purged from the lines.
- 2) The dryer is equipped with a Direct Spark Ignition (DSI) system which has internal diagnostics. If ignition is not established after the first attempt, the system will retry two (2) more times. If ignition is not established after three (3) attempts, the heat circuit DSI module will lockout until it is manually reset. To reset the DSI system, open and close main doors and restart dryer (press "ENTER/START" key).

NOTE: During the purging period, verify that **ALL** gas shut-off valves are open.

- 3) Once ignition is established, a gas pressure test **should be** taken at the gas valve pressure tap of each dryer to assure that the water column pressure is correct and consistent.

NOTE: Water column (W.C.) pressure requirements (measured at both gas valve pressure taps)...

NATURAL GAS ----- 3.5 INCHES W.C. (8.7 mb).

L.P. GAS ----- 10.5 INCHES W.C. (26.1 mb).

IMPORTANT: There is no regulator provided in an L.P. dryer. The water column (W.C.) pressure **must be** regulated at the source (L.P. tank), or an external regulator **must be** added to each dryer.

b. Steam Models

- 1) Check to insure that the steam damper is functioning properly.
6. Make a complete operational check of **ALL** safety-related circuits (i.e., lint drawer switch and sail switches on Gas Models).
7. A reversing tumbler (basket) **should never be** operated with less than a 50 pound (22 kg) load (dry weight). The size of the load will affect the coast-down and dwell (stop) times. The tumbler **must come** to a complete stop before starting in the opposite direction. For automatic (mode) cycle only, the spin and stop times are not adjustable and have been preprogrammed into the microprocessor controller (computer) for a 2 minute spin time and a 5-second dwell (stop) time.

BASKET COATING

The tumbler (basket) is treated with a protective coating. We suggest dampening old garments or cloth material with a solution of water and non-flammable mild detergent and tumbling them in the tumbler (basket) to remove this coating.

8. Each dryer **should be** operated through one (1) complete cycle to assure that no further adjustments are necessary and that **ALL** components are functioning properly.
9. Microprocessor (computer) programs/selections...
 - a. Each microprocessor controller (computer) has been preprogrammed by the factory with the most commonly used parameter selections. If computer program changes are required, refer to the Computer Programming Manual which was shipped with the dryer.

K. SHUT DOWN INSTRUCTIONS

In the case where the dryer is to be shut down (taken out of service) for a period of time, the following **must be** performed:

1. Discontinue power to the dryer either at the external disconnect switch or the circuit breaker.
2. Disconnect the heat supply:
 - a. ***GAS MODELS* ... discontinue the gas supply.**
 - 1) **SHUT OFF external gas supply shut-off valve.**
 - 2) **SHUT OFF internal gas supply shut-off valve located in the gas valve burner area.**
 - b. ***STEAM MODELS* ... discontinue steam supply.**
 - 1) **SHUT OFF external (location furnished) shut-off valve.**
 - 2) **SHUT OFF internal steam valves in the supply lines and the return lines.**

SECTION IV

SERVICE/PARTS INFORMATION

A. SERVICE

1. Service **must be** performed by a qualified trained technician, service agency, or gas supplier. If service is required, contact the distributor from whom the **ADC** equipment was purchased. If the distributor **cannot** be contacted or is unknown, contact the **ADC** Service Department for a distributor in your area.

NOTE: When contacting the **ADC** Service Department, be sure to give them the correct **model number** and **serial number** so that your inquiry is handled in an expeditious manner.

B. PARTS

1. Replacement parts **should be** purchased from the distributor from whom the **ADC** equipment was purchased. If the distributor **cannot** be contacted or is unknown, contact the **ADC** Parts Department for a distributor in your area. Parts may also be purchased directly from the factory by calling the **ADC** Parts Department at (508) 678-9000 or you may FAX in your order at (508) 678-9447.

NOTE: When ordering replacement parts from the **ADC** dealer or the **ADC** factory be sure to give them the correct **model number** and **serial number** so that your parts order can be processed in an expeditious manner.

SECTION V

WARRANTY INFORMATION

A. RETURNING WARRANTY CARD(S)

1. Before any dryer leaves the **ADC** factory test area, a warranty card is placed on the back side of the main door glass. These warranty cards are intended to serve the customer where we record the individual installation date and warranty information to better serve you, if you file a warranty claim.
 - a. If a warranty card did not come with your dryer, contact the **ADC** Warranty Department or **ADC** Service Department at (508) 678-9000.

B. WARRANTY

For a copy of the **ADC** commercial warranty covering your particular dryer(s), contact the **ADC** distributor from whom you purchased the equipment and request dryer warranty form. If the distributor **cannot** be contacted or is unknown, warranty information can be obtained from the factory by contacting the **ADC** Warranty Department at (508) 678-9000.

NOTE: Whenever contacting the **ADC** factory for warranty or warranty information, be sure to have the dryer's **model number** and **serial number** available so that your inquiry can be handled in an expeditious manner.

C. RETURNING WARRANTY PART(S)

ALL dryer or parts warranty claims or inquiries **should be** addressed to the **ADC** Warranty Parts Department. To expedite processing, the following procedures **must be** followed:

1. No parts are to be returned to **ADC** without prior written authorization ("Return Material Authorization") from the factory.

NOTE: A.R.M.A. ("Return Material Authorization") is valid for only sixty (60) days from date of issue.

- a. The R.M.A. issued by the factory, as well as any other correspondence pertaining to the returned part(s), **must be** included inside the package with the failed merchandise.

2. Each part **must be** tagged with the following information:
 - a. **Model number** and **serial number** of the dryer from which part was removed.
 - b. Nature of failure (be specific).
 - c. Date of dryer installation.
 - d. Date of part failure.
 - e. Specify whether the part(s) being returned is for a replacement, a credit, or a refund.

NOTE: If a part is marked for a credit or a refund, the invoice number covering the purchase of the replacement part **must be** provided.

NOTE: Warranty tags (ADC Part No. 450064) are available at "no charge" from ADC upon request.

3. The company returning the part(s) **must clearly** note the complete company name and address on the outside of the package.
4. **ALL** returns **must be** properly packaged to insure that they are not damaged in transit. *Damage claims are the responsibility of the shipper.*

IMPORTANT: No replacements, credits, or refunds **will be** issued for merchandise damaged in transit.

5. **ALL** returns **should be** shipped to the ADC factory in such a manner that they are insured and a proof of delivery can be obtained by the sender.
6. **Shipping charges are not the responsibility of ADC. ALL returns should be "prepaid" to the factory. Any "C.O.D." or "COLLECT" returns will not be accepted.**

IMPORTANT: No replacements, credits, or refunds **will be** issued if the claim **cannot** be processed due to insufficient information. The party filing the claim **will be** notified in writing, either by "FAX" or "CERTIFIED MAIL - Return Receipt Requested," as to the information necessary to process claim. If a reply **is not** received by the ADC Warranty Department within thirty (30) days from the FAX/letter date, then no replacement, credit, or refund **will be** issued, and the merchandise **will be discarded.**

SECTION VI

ROUTINE MAINTENANCE

A. CLEANING

A program and/or schedule **should be** established for periodic inspection, cleaning, and removal of lint from various areas of the dryer, as well as throughout the duct work system. The frequency of cleaning can best be determined from experience at each location. Maximum operating efficiency is dependent upon proper air circulation. The accumulation of lint can restrict this airflow. If the guidelines in this section are met, an ADC dryer will provide many years of efficient, trouble-free, and - most importantly - safe operation.

WARNING: LINT FROM MOST FABRICS IS HIGHLY COMBUSTIBLE. THE ACCUMULATION OF LINT CAN CREATE A POTENTIAL FIRE HAZARD.

WARNING: KEEP DRYER AREA CLEAR and FREE FROM COMBUSTIBLE MATERIALS, GASOLINE, and OTHER FLAMMABLE VAPORS and LIQUIDS.

NOTE: Suggested time intervals shown are for average usage which is considered six (6) to eight (8) operational (running) hours per day.

SUGGESTED CLEANING SCHEDULE

AFTER EVERY LOAD

Clean the lint basket. A clogged lint basket will cause poor dryer performance. The lint basket is located in the lint drawer in the base of the dryer. Pull out the lint drawer, brush the lint off the lint basket, and remove the lint. Inspect lint screen and replace if torn.

NOTE: Frequency of cleaning the lint screen can best be determined from experience at each location.

WEEKLY

Open the hinged panels on each side of the tumbler section and remove any lint accumulation, from the tumbler drive motor, drive shafts, gear reducer, V-belts, drive wheels, and drive shaft bearings.

Slide the lint basket **ALL** the way out of the dryer and clean any lint accumulation off of the temperature sensor bracket, which is located above the lint basket.

WARNING: TO AVOID THE HAZARD OF ELECTRICAL SHOCK, DISCONTINUE ELECTRICAL SUPPLY TO THE DRYER.

STEAM DRYERS ONLY

Clean the steam coil lint screen located on top of the steam coil. (This may have to be done more frequently.)

MONTHLY

Retighten set screws in the collars of the four (4) 1-1/2" (3.81 cm) diameter tumbler drive shaft bearings.

Clean lint accumulation from the gas valve/burner area at the top of the dryer, the fan (impellor) motor, and the fan (impellor) bearings located in the dryer base.

NOTE: To prevent damage, avoid cleaning and/or touching ignitor/flame-probe assembly.

EVERY 6 MONTHS

Check V-belts for tightness and wear. Retighten or replace if required.

On steam dryers, clean steam coil fins. We suggest using compressed air and a vacuum cleaner with brush attachment.

NOTE: When cleaning steam coil fins, be careful not to bend the fins. If fins are bent, straighten by using a fin comb which is available from local air conditioning supply house.

Inspect and remove lint accumulation in customer furnished exhaust duct work system and from dryer's internal exhaust ducting.

WARNING: THE ACCUMULATION OF LINT IN THE EXHAUST DUCT WORK CAN CREATE A POTENTIAL FIRE HAZARD.

WARNING: *DO NOT* OBSTRUCT THE FLOW OF COMBUSTION and VENTILATION AIR. CHECK CUSTOMER FURNISHED BACK DRAFT DAMPERS IN THE EXHAUST DUCT WORK. INSPECT and REMOVE ANY LINT ACCUMULATION WHICH CAN CAUSE THE DAMPER TO BIND or STICK.

NOTE: A back draft damper that is sticking partially closed can result in a slow drying and shut down of the heat circuit safety switches or thermostats.

NOTE: When cleaning the dryer cabinet(s), avoid using harsh abrasives. A product intended for the cleaning of appliances is recommended.

B. ADJUSTMENTS

7 DAYS AFTER INSTALLATION and EVERY 6 MONTHS THEREAFTER

Inspect bolts, nuts, screws (bearing set screws), non-permanent gas connections (unions, shut-off valves, orifices, and grounding connections). Motor and drive belts **should be** examined. Cracked or seriously frayed belts **should be** replaced. Tighten loose V-belts when necessary. Complete operational check of controls and valves. Complete operational check of **ALL** safety devices (door switch, lint drawer switch, sail switch, burner and hi-limit thermostats).

C. LUBRICATION

MONTHLY

The two (2) bearings that support the impellor/fan shaft **must be** lubricated. Use Shell Alvania #2 grease or its equivalent. Generically, this grease would be described as an NLGI Grade 2 multipurpose industrial grease with a lithium thickener and mineral base oil.

EVERY 3 MONTHS

The four (4) bearings that support the drive and idler shafts **must be** lubricated. Use Shell Alvania #2 grease or its equivalent. Generically, this grease would be described as an NLGI Grade 2 multipurpose industrial grease with a lithium thickener and mineral base oil.

SECTION VII

COMPONENT SYSTEM DESCRIPTIONS

A. TUMBLER (BASKET) DRIVE SYSTEM

The tumbler (basket) is supported and driven by four (4) 11-inch (27.94 cm) diameter drive wheels. Two (2) of these wheels are attached to a 1-1/2" (3.81 cm) diameter idler shaft, while the other two (2) are attached to a 1-1/2" (3.81 cm) diameter drive shaft. Each of the wheels is fastened to the shafts by a locking bushing. The taper lock is made up of two (2) pieces; an inner collar, and an outer sleeve. The inner and outer elements have matching opposing tapers. As a result, when the nut is tightened, the trantorque contracts onto the shaft and expands into the drive wheel hub locking the wheel onto the shaft.

The idler shaft and drive shaft are each supported by two (2) 1-1/2" (3.81 cm) diameter pillow block bearings. These bearings sit on slotted support channels and can be moved inward or outward by the adjustment bolts to raise or lower the tumbler (basket). The drive shaft sticks out through the back of the dryer and has a 2B V-belt pulley attached to it with a keypad taper lock bushing. This pulley is connected to a speed reducing idler and then to the 3 HP (2.23 kw) drive motor by two (2) sets of V-belts.

The speed reducing idler shaft is supported by two (2) 1-1/4" (3.18 cm) diameter pillow block bearings. These pillow blocks sit on a slotted platform, and they can be moved forward and back by loosening or tightening the bearing adjustment bolts. This movement is needed to maintain proper tension on the V-belts that run from the speed-reducing idler to the drive shaft.

The drive motor sits on an adjustable base so that the motor can be moved forward and back, allowing proper tension to be maintained on the V-belts that run from the motor to the speed-reducing idler.

B. TUMBLER/BASKET

The tumbler (basket) is made of 14-gauge stainless steel perforated panels, four (4) stainless steel ribs, and two (2) outer tumbler/basket rings. The tumbler (basket) is a completely welded assembly so the perforated panels are not removable.

C. AIR BLOWER DRIVE SYSTEM

The impellor (fan) used in the ML-200 dryer is a 15-inch (38.1 cm) diameter backwardly inclined squirrel cage impellor (fan) wheel. It spins in a counterclockwise (CCW) direction looking at the back of the blower housing.

The impellor/fan shaft is mounted in two (2) 1-3/8" (3.49 cm) diameter pillow block bearings, and the shaft is driven by two (2) B-section V-belts connected to the blower motor.

The blower motor is mounted on an adjustable base. The motor position can be easily adjusted so that proper tension can be maintained on the V-belts.

D. SAFETY DEVICES

1. Load Door Switches

There are two (2) of these switches located under the main loading doors. These switches ensure that the doors are closed before the dryer can start. If the dryer is started when the load doors are open, the microprocessor controller (computer) L.E.D. (light emitting diode) display will show "door."

2. Lint Basket Switch

This switch ensures that the lint basket is closed before the dryer can start. This switch is located at the front of the dryer at the right side of the lint basket. If the lint basket is open when the dryer is started, then the microprocessor controller (computer) L.E.D. display will show "door."

3. Tumbler (Basket) Hi-Limit Safety Thermostat

This disk temperature switch has a setting of 225° F (107° C). It is located below the tumbler (basket) on the temperature sensor bracket, along side the computer sensor, and is an automatic reset type of switch. Access to this switch is gained by sliding/pulling the lint basket completely out of the dryer.

This switch backs up the computer sensor and in case of a computer sensor malfunction will prevent the tumbler's (basket's) temperature from becoming excessive. If this switch trips, the gas flow to the burner box **will be** shut down; however, the tumbler (basket) will still rotate.

4. Burner Box Hi-Limit Safety Thermostat

This disk temperature switch has a setting of 330° F (165° C). It is located on the right side of the burner box, and it is a manual reset type of switch. This switch ensures that there is proper airflow through the burner box. Upon a low airflow condition, which may be caused by a clogged lint screen, excessively long or blocked exhaust duct, or improper make-up air, the temperature in the burner box will increase tripping this switch. This will shut off the gas flow to the burner box and the dryer will not heat until this thermostat is reset, however the tumbler (basket) will still run.

5. Sail Switch *(for Gas Dryers ONLY)*

The sail switch is located in the front top of the burner box. A sail switch consists of a round damper plate on a lever arm which is in contact with an electric switch. When the air blower comes on, it draws air through the gas burner. This creates a negative pressure inside the burner box, and this negative pressure pulls in the round damper and activates the sail switch. If there is an improper (low) airflow through the dryer, the sail switch damper will not pull in, preventing the heat from coming on.

Low airflow through the dryer will be caused by overly long or blocked exhaust ducting, lack of make-up air, or a clogged lint screen.

E. STEAM DAMPER ACTUATOR SYSTEM

The system consists of a hinged damper plate, pneumatic piston, and 24 volt solenoid valve with a needle valve to control the speed of the piston actuation. On a call for heat, a 24 volt signal is applied to the 3-way/2-position solenoid valve. This signal switches the valve so that compressed air is sent to the pistons. The piston rod extends, pushing the hinged steam damper plate to the opened position. This allows room air to be drawn through the hot steam coil and then through the tumbler (basket).

When the temperature set point has been reached, the 24 volt signal is removed from the solenoid valve, so that the solenoid valve blocks the air supply to the piston, and the air in the piston is bled to the atmosphere. The spring in the piston now retract the piston rod, closing the steam damper: The steam damper plate now covers the steam coil and allows room air to bypass the coil before entering the tumbler (basket) for a rapid cool down.

The steam damper plate should open and close slowly and smoothly. The speed can be modulated by adjusting the needle valve knob. Turning the knob clockwise (CW) restricts the compressed airflow and slows down the steam damper movement. Counterclockwise (CCW) adjustment speeds up the steam damper motion. Upon completion of adjustment, tighten the needle valve's locking nut.

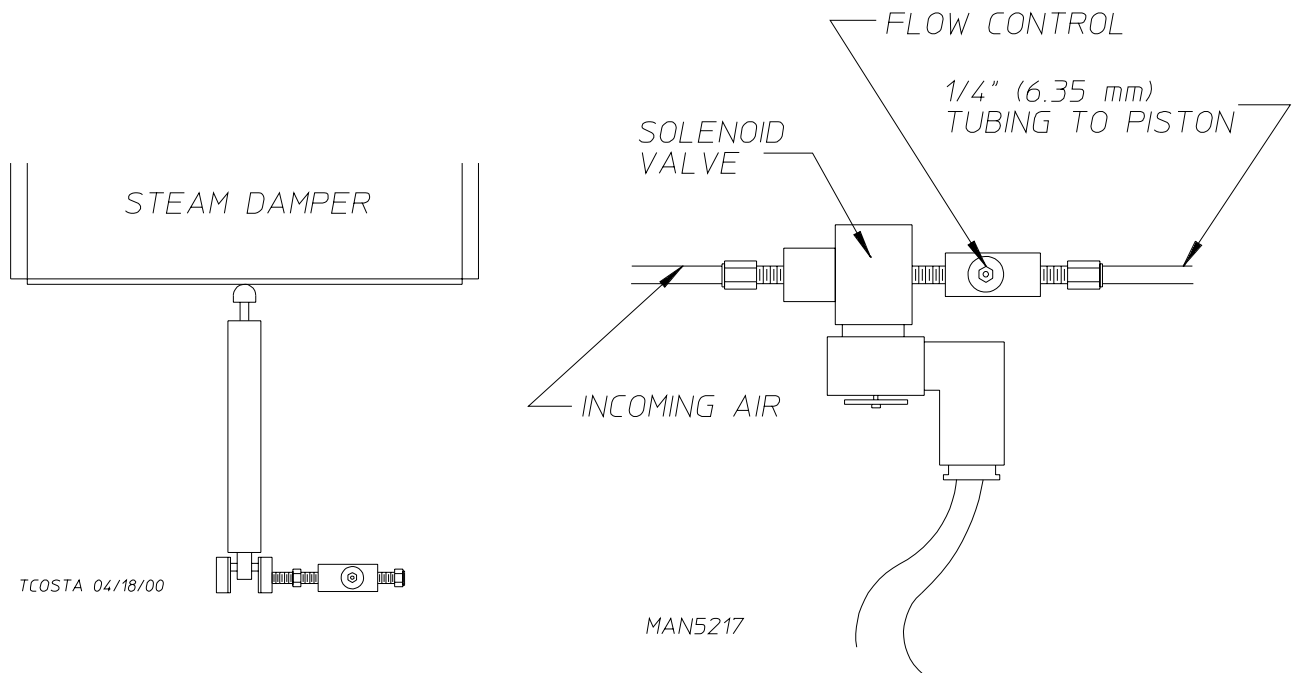

TCOSTA 04/18/00

SECTION VIII

TROUBLESHOOTING

IMPORTANT: YOU MUST DISCONNECT and LOCKOUT THE ELECTRIC SUPPLY and THE GAS SUPPLY or THE STEAM SUPPLY BEFORE ANY COVERS or GUARDS ARE REMOVED FROM THE MACHINE TO ALLOW ACCESS FOR CLEANING, ADJUSTING, INSTALLATION, or TESTING OF ANY EQUIPMENT per OSHA (Occupational Safety and Health Administration) STANDARDS.

The information provided will help isolate the most probable component(s) associated with the difficulty described. The experienced technician realizes, however, that a loose connection or broken/shorted wire may be at fault where electrical components are concerned ... and not necessarily the suspected component itself. Electrical parts **should always be** checked for failure before being returned to the factory. The information provided **should not be** misconstrued as a handbook for use by an untrained person making repairs.

IMPORTANT: When replacing blown fuses, the replacement *must be* of the exact rating as the fuse being replaced. For information provided *should not be* misconstrued as a handbook for use by an untrained person in making repairs.

WARNING: ALL SERVICE and TROUBLESHOOTING *SHOULD BE* PERFORMED BY A QUALIFIED PROFESSIONAL or SERVICE AGENCY.

WARNING: WHILE MAKING REPAIRS, OBSERVE ALL SAFETY PRECAUTIONS DISPLAYED ON THE DRYER or SPECIFIED IN THIS MANUAL.

A. No Display...

1. Service panel fuses blown or tripped breaker.
2. Blown F1 (fuse 1) or F2 (fuse 2) on left hand control panel.
3. Failed microprocessor controller (computer).

B. Drive motor is not operating (does not start)...

- * Microprocessor controller (computer) relay output indicator (either forward "FWD" or reverse "REV") is on.
1. Blown drive motor conductor fuse(s)/overload(s).

2. Failed drive motor contactor.
3. Failed drive motor.
4. Failed microprocessor controller (computer).

C. Drive motor operates in one direction only ... stops and restarts in same direction...

* **Appropriate microprocessor controller (computer) relay output indicator is on.**

1. Failed reversing contactor (relay).

* **Appropriate microprocessor controller (computer) relay output indicator is off.**

1. Failed microprocessor controller (computer).

D. Drive motor operates okay for a few minutes, and then either repeatedly or occasionally trips the overload protector...

NOTE: When the overload protector trips, the microprocessor controller (computer) L.E.D. (light emitting diode) display will read "door."

1. Motor is overheating ...
 - a. Motor air vents clogged with lint.
 - b. Low voltage to the motor.
 - c. Failed motor.
 - d. Tumbler (basket) is binding ... check for obstruction.
 - e. Failed idler bearings or tumbler bearings.
 - f. V-belts are too tight.
2. Failed overload protector.

E. Impellor (fan) motor is not operating (does not start)...

* **Microprocessor controller (computer) "MTR" relay output indicator is on.**

1. Blown blower (impellor/fan) motor contactor fuse(s)/overload(s).
2. Failed blower (impellor/fan) motor contactor (relay)..
3. Failed blower (impellor/fan) motor.

* Microprocessor controller (computer) "MTR" relay output indicator is off.

1. Failed microprocessor controller (computer).

F. Blower (fan/impellor) motor operates okay for a few minutes, then either repeatedly or occasionally trips the overload protector...

NOTE: When the overload protector trips, the microprocessor controller (computer) L.E.D. (light emitting diode) display will read "door."

1. Motor is overheating ...

- a. Motor air vents clogged with lint.
- b. Low voltage to the motor.
- c. Failed motor.
- d. Failed impellor/fan drive bearings.
- e. V-belts are too tight.

2. Failed overload protector.

G. Both drive motor and blower (impellor/fan) motor are not operating... microprocessor controller (computer) L.E.D. (light emitting diode) motor indicator dots and the "MTR" relay output and forward "FWD" or reverse "REV" L.E.D. indicators are on.

1. Blown drive motor and blower (fan/impellor) motor fuse(s) / overload(s).

2. Failed motors (both blower [fan/impellor] and drive).

H. Both drive motor and blower (fan/impellor) motor not operating... microprocessor controller (computer) L.E.D. (light emitting diode) motor indicator dots and the "door" L.E.D. indicator are on but relay output L.E.D. indicators are off (microprocessor controller [computer] L.E.D. display does not read "door")...

1. Failed microprocessor controller (computer).

I. Both drive motor and blower (impellor/fan) motor run for a few minutes then stop... microprocessor controller (computer) L.E.D. (light emitting diode) display continues to read time or percent of extraction and ALL indicator dots are off...

1. Fault in main door switch circuit ...

- a. One (1) of the main door switches are out of adjustment.
- b. Loose connection somewhere in the door switch circuit.

2. Fault in the lint drawer switch circuit.

- a. Lint drawer switch is out of proper adjustment.
- b. Loose connection in the lint drawer switch circuit.

J. Microprocessor controller (computer) L.E.D. (light emitting diode) display reads "dSFL" continuously and the buzzer (tone) sounds every 30-seconds...

- 1. Fault in microprocessor heat sensing circuit ...
 - a. Failed microprocessor temperature sensor.
 - b. Blown "dSFL" 1/8-amp fuse on the microprocessor controller (computer).
 - c. Failed microprocessor controller (computer).
 - d. Broken wire or connection somewhere between the microprocessor controller (computer) and the microprocessor temperature sensor.

K. Microprocessor controller (computer) L.E.D. (light emitting diode) display reads "door" and the microprocessor controller "door" L.E.D. indicator is off...

- 1. Fault (open circuit) in main door/lint drawer switch circuit ...
 - a. Lint drawer is not closed **ALL** the way.
 - b. Lint drawer switch is out of proper adjustment.
 - c. Failed lint drawer switch.
 - d. One (1) of the main door switches has failed.
 - e. One (1) of the main door switch contact magnets is either missing or broken.
 - f. Failed door switch relay.
 - g. Broken wire/connection in main door or lint drawer switch circuit.
- 2. Failed 24 VAC step down transformer.
- 3. Drive and/or blower (impellor/fan) motor thermal overload reset had tripped.

4. Blown 24 VAC control circuit fuse (fuse 3).
- L. Microprocessor controller (computer) L.E.D. (light emitting diode) display reads "door" and the microprocessor controller (computer) "DOOR" L.E.D. indicator is on...**
1. Failed microprocessor controller (computer).
- M. Microprocessor controller (computer) will not accept any keyboard (touchpad) entries, i.e., display reads "FILL" and when keyboard (touchpad) entries are selected, the display continues to read "FILL"...**
1. Failed keyboard (touchpad) label assembly.
 2. Failed microprocessor controller (computer).
- N. Microprocessor controller (computer) will only accept certain keyboard (touchpad) entries...**
1. Failed keyboard (touchpad) label assembly.
- O. Microprocessor controller (computer) locks up and L.E.D. (light emitting diode) display reads erroneous message(s) or only partial segments...**
1. Transient power voltage (spikes)...disconnect power to dryer, wait one minute and reestablish power to dryer. If problem is still evident ...
 - a. Failed microprocessor controller (computer).
 - b. Failed keyboard (touchpad) label assembly.
- P. Dryer stops during a cycle, microprocessor controller (computer) buzzer (tone) sounds for 5-seconds, L.E.D. (light emitting diode) display reads "dSFL" for approximately 30-seconds and then returns to "FILL"...**
1. Loose connection somewhere between the microprocessor controller (computer) and the microprocessor temperature sensor.
- Q. Dryer stops during a cycle, microprocessor controller (computer) buzzer (tone) sounds only for a few seconds, and then the microprocessor controller (computer) L.E.D. (light emitting diode) display returns to "FILL"...**
1. Loose connection somewhere in the main power circuit to the microprocessor controller (computer).
- R. Microprocessor controller (computer) L.E.D. (light emitting diode) display reads "SEFL"...**
1. Microprocessor controller (computer) program (Program Location 2) is set incorrectly in the active mode ("Sen") where the dryer is not equipped with the *optional* rotation sensor...program **must be** set as "nSen."

2. Rotational sensor circuit failure...fault somewhere in the tumbler (basket) rotation or circuit...
 - a. Tumbler (basket) is not rotating...
 - 1) Broken tumbler (basket) drive V-belt(s).
 - 2) Failure in drive motor circuit...refer to **Section B**, **Section C**, and **Section D** on **page 42** and **page 43**.
 - b. Faulty rotation sensor.
 - c. Broken wire or connection between rotation sensor and microprocessor controller (computer).

S. Microprocessor controller (computer) L.E.D. (light emitting diode) display reads "Hot"...

1. Possible overheating condition...microprocessor controller (computer) has sensed a temperature which has exceeded 220° F (104° C).

"Hot" display will not clear until temperature sensed has dropped to 220° F (104° C) or lower and the micro processor controller (computer) is manually reset by pressing the "CLEAR/STOP" key.

T. Gas heating unit is not operating (no heat)...no spark at burner area when the dryers is first started, and both the heat indicator dot and the "HEAT" relay output L.E.D. (light emitting diode) are on...

1. Fault in sail switch circuit...
 - a. Sail switch is out of adjustment or has failed.
 - b. Sail switch damper is not closing or is fluttering.
 - 1) Lint drawer/screen is dirty.
 - 2) Restriction in exhaust.
 - 3) No exhaust airflow.
2. Fault in burner hi-limit circuit or tripped manual reset hi-limit (Gas Only) thermostat.
3. Fault in 225° F (107° C) hi-limit circuit or tripped manual reset hi-limit thermostat.
4. Failed Direct Spark Ignition (DSI) module.
5. Failed DSI igniter/flame-probe assembly.

U. Heating unit for GAS MODELS or STEAM MODELS is not operating (no heat) and the microprocessor controller (computer) L.E.D. (light emitting diode) heat indicator dot is on but the "HEAT" relay output L.E.D. is not on...

1. Failed microprocessor controller (computer).

V. No heat for GAS MODELS ONLY...ignitor sparks, burner goes on then off right away...

1. DSI (Direct Spark Ignition) ignitor/flame-probe out of adjustment...reposition closer to the flame area.
2. Sail switch is fluttering ...
 - a. Lint drawer/screen is dirty.
 - b. Restriction in exhaust duct work.
 - c. Blower impellor/fan going the wrong direction.
3. Insufficient make-up air.
4. Failed ignitor/flame-probe assembly.
5. Failed Direct Spark Ignition (DSI) module.
6. Failed gas valve.

W. No heat for STEAM MODELS ONLY ...both microprocessor controller (computer) L.E.D. (light emitting diode) heat indicator dot and the "HEAT" relay output L.E.D. are on...

1. Fault in 225° F (107° C) hi-heat (limit) switch circuit or tripped manual reset hi-limit thermostat.
2. No (external) compressed air to steam damper...80 PSI (5.51 bars) required.
3. Failed steam damper 24 VAC pneumatic solenoid valve.
4. Failed steam damper piston.
5. Steam damper stuck closed.

X. Dryer operates but is taking too long to dry...

1. Exhaust duct work run too long or is undersized...back pressure **cannot** exceed 0.3 inches W.C. (0.74 mb).
2. Restriction in duct work...check duct from dryer **ALL** the way to the outdoors.
3. Low and/or inconsistent gas pressure ... *for GAS MODELS ONLY.*
4. Insufficient make-up air.
5. Poor air/gas mixture at burner - yellow or poor flame pattern...adjust gas burner air adjustment shutters ... *for GAS MODELS ONLY.*

6. Lint drawer/screen is not being cleaned on a regular basis or often enough.
7. Extractors (washers) are not performing properly.
8. Sail switch is fluttering...restriction in exhaust...*for GAS MODELS ONLY.*
9. Failed microprocessor controller (computer)...temperature calibration is inaccurate.
10. Failed microprocessor temperature sensor...calibration is inaccurate.
11. Steam damper system is not functioning properly ...*for STEAM MODELS ONLY..*
 - a. Steam damper sticking closed.
 - b. Leak in pneumatic system.

Y. Excessive noise and/or vibration...

1. Dryer is not leveled properly.
2. Impellor (fan) out of balance ...
 - a. Excessive lint build up on impellor (fan)...check air jet.
 - b. Failed impellor (fan).
3. Loose motor mount.
4. Failed idler bearings and/or tumbler bearings.
5. V-belt(s) either too tight or too loose.
6. Tumbler (basket) drive wheels are worn or loose.
7. Set screws of the tumbler drive shaft bearings are too loose.
8. Failed motor bearings.
9. Drive wheel trantorque is too loose.

Z. Scrapping or rubbing noise in tumbler (basket) area or around front or rear panels...

1. Check for object(s) caught somewhere in tumbler (basket).
2. Misadjusted thrust wheel(s).
3. Failed thrust wheel(s).

AA. Tumbler (basket) jumps or makes excessive noise when dryer is first started or between forward and reverse cycles...

1. Tumbler (basket) out of alignment.

BB. Blower (impellor/fan) air jet does not activate at the end of the cooling cycle...

* With microprocessor controller (computer) "A JET" relay output L.E.D. (light emitting diode) **is on**.

1. Fault in compressed air supply.

2. Failed air jet.

* With microprocessor controller (computer) "A JET" relay output L.E.D. (light emitting diode) **is off**.

1. Failed microprocessor controller (computer)..

SECTION IX

PROCEDURE FOR FUNCTIONAL CHECK OF REPLACEMENT COMPONENTS

1. Microprocessor (computer) Board

- a. Upon completing installation of the replacement microprocessor (computer) board, reestablish power to the dryer.
- b. Start the drying cycle.
- c. Verify that the motor(s) and the heat indicator dots, in the microprocessor (computer) L.E.D. (light emitting diode) display are on. (Refer to the **illustration** below.)

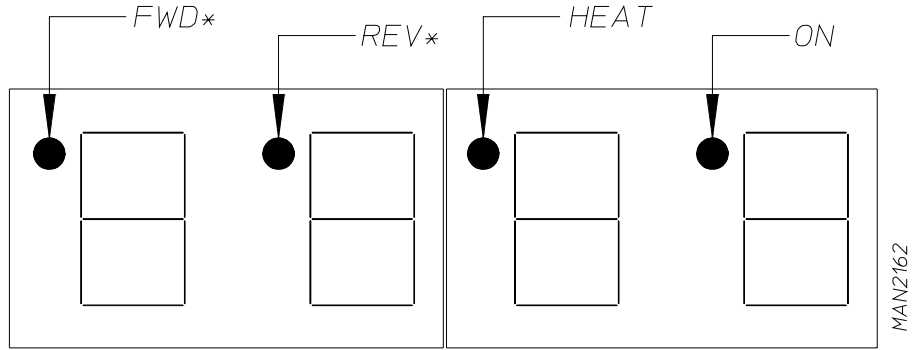

*OPL (NON-COIN) REVERSING MODELS ONLY.

- d. Verify that motor(s) heat, and door indicator lights on the back side of the microprocessor (computer) board are lit. (Refer to **illustration** below.)

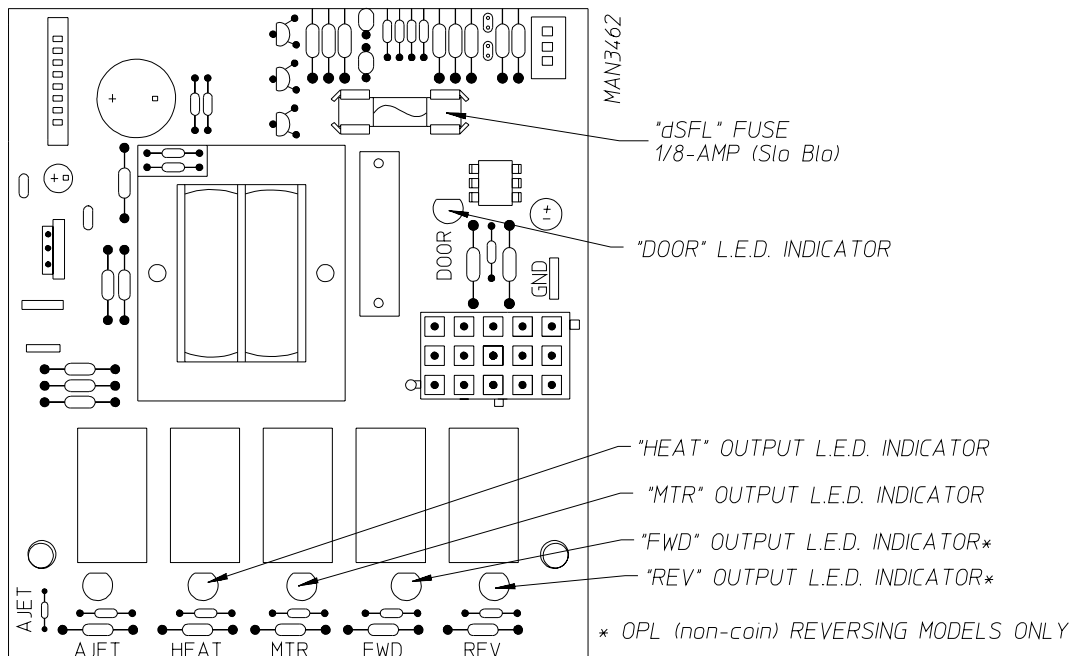

- e. Open main door. The dryer **must stop** and **ALL** output indicator lights on the back side of the microprocessor (computer) board **must go out**.
 - f. Try to restart the dryer with the main door open.
 - g. The microprocessor (computer) board's L.E.D. (light emitting diode) display **must read "DOOR."**
 - h. Close the main door and restart the dryer.
 - i. Functional check of microprocessor (computer) board is complete.
2. For Models With Johnson Controls DSI (Direct Spark Ignition) Module (G760)

Theory Of Operation;

Start the drying cycle. When the gas burner ignites within the chosen trial for ignition time (6-seconds), the flame sensor detects gas burner flame and signals the Direct Spark Ignition (DSI) module to keep the gas valve open...as long as there is a call for heat. The DSI module will "LOCKOUT" if the gas burner flame is not sensed at the end of the trial for ignition period. The trial for ignition period will be repeated for a total of three (3) retries/trials (the initial try and two [2] more retries/trials). If the flame is not sensed at the end of the third retry/trial (inter-purge period of 30-seconds) the DSI module will "LOCKOUT" (L.E.D. [light emitting diode] flashes).

A steady L.E.D. (light emitting diode) indicator indicates normal operation.

No L.E.D. (light emitting diode) indicator indicates a power or an internal failure has occurred.

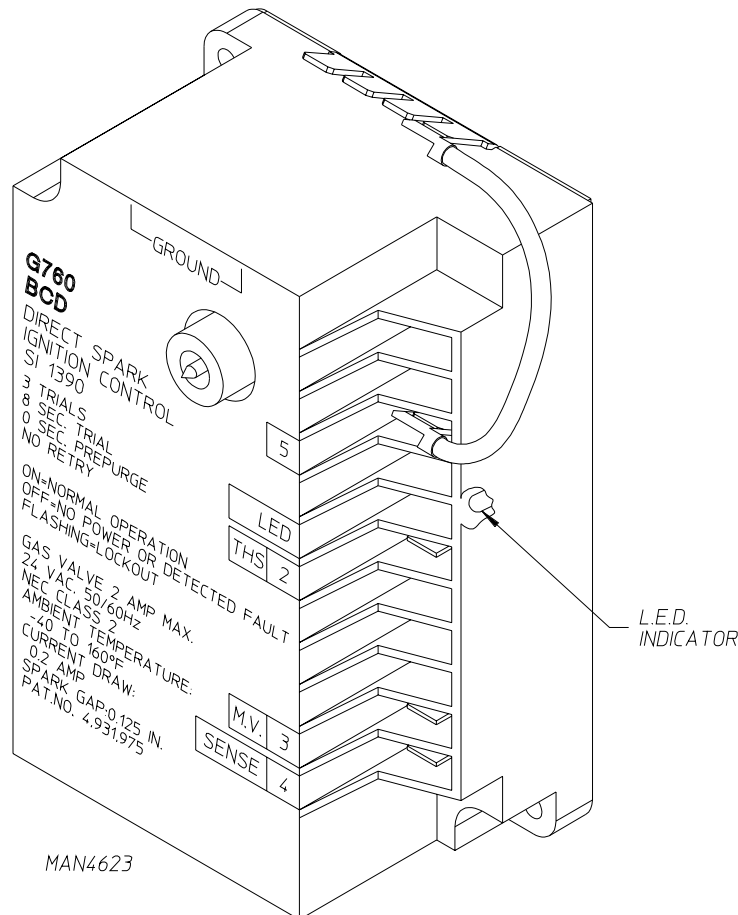

3. For Direct Spark Ignition (DSI) System Models Manufactured With ADC Module Part No. 880815

a. Upon completing installation of the replacement Direct Spark Ignition (DSI) module, reestablish power to the dryer.

b. Start the drying cycle.

c. The ignition (DSI) module's L.E.D. (light emitting diode) indicator will be "off" for up to approximately 1.5-seconds (prepurge time).

d. The module's indicator light will then turn "green." The gas valve will be energized and the ignitor probe will spark for approximately 8-seconds. The burner flame **should now be** established. If the L.E.D. on the module lights "green" continuously, then the system is functioning properly. A flashing "green" L.E.D. (lockout mode) indicates that ignition flame has not been confirmed.

e. With the burner flame on, remove the flame sensor wire from the sense terminal of the DSI module.

f. The burner flame **must shut off** and the ignition module **must lockout** with the DSI module's indicator light flashing "green."

g. Stop the drying cycle, with the flame sensor wire still removed, restart the drying cycle.

h. The ignition module **must proceed** through the prepurge, with the indicator light "off," the ignition trial time of approximately 8-seconds, with the indicator light "green," and then proceed to lockout with the indicator light flashing "green."

i. Functional check of the Direct Spark Ignition (DSI) Module is complete.

1) Replace the flame sensor wire from the FS terminal to the DSI module.

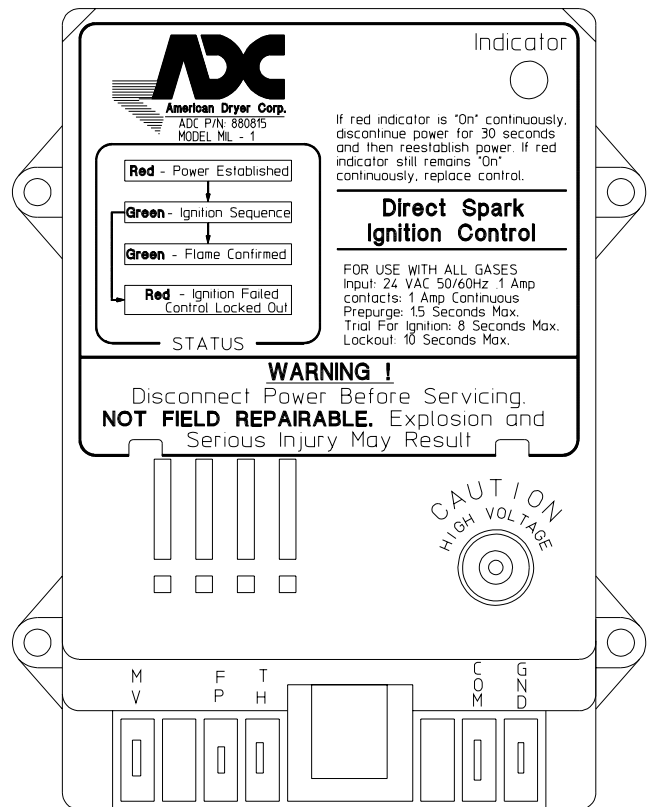

SECTION X

MANUAL RESET HI-LIMIT INSTRUCTIONS

IMPORTANT

MANUAL RESET HI-LIMIT INSTRUCTIONS

FOR GAS MODELS WITH PHASE 5

This dryer was manufactured with a manual reset burner hi-limit and tumbler/lint chamber hi-limit thermostat which is monitored by the Phase 5 computer. If either manual reset thermostat is open prior to start of the drying cycle, the dryer will start momentarily and then shut down.

The open manual reset hi-limit thermostat **must be** reset “manually” prior to the start of the next cycle.

This hi-temperature condition may be caused due to a restricted exhaust, poor airflow or improper burner oven operation.

The location of the manual reset hi-limit is on the right side of the burner box and the tumbler hi-limit is located in the lint chamber area.

WARNING: Discontinue power to dryer before attempting to reset hi-limit.

IMPORTANT

This dryer is equipped with a burner hi-limit and tumbler/lint chamber hi-limit thermostat which must be reset manually.

WARNING: Discontinue power to dryer before attempting to reset hi-limit.

ADC P/N: 114093

